

DGLYJJ-V1

FTLFTS-6030

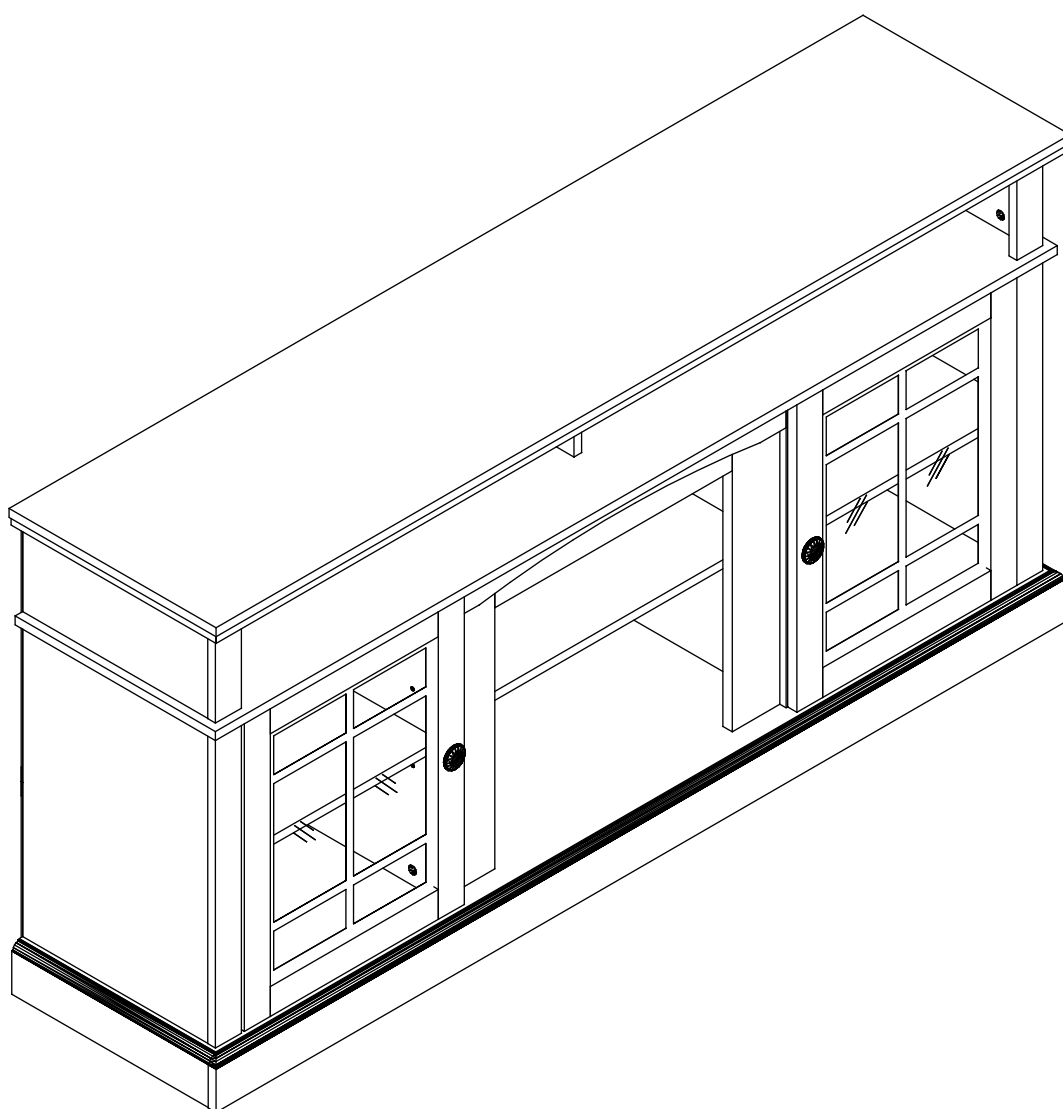



FTLFTS-6094



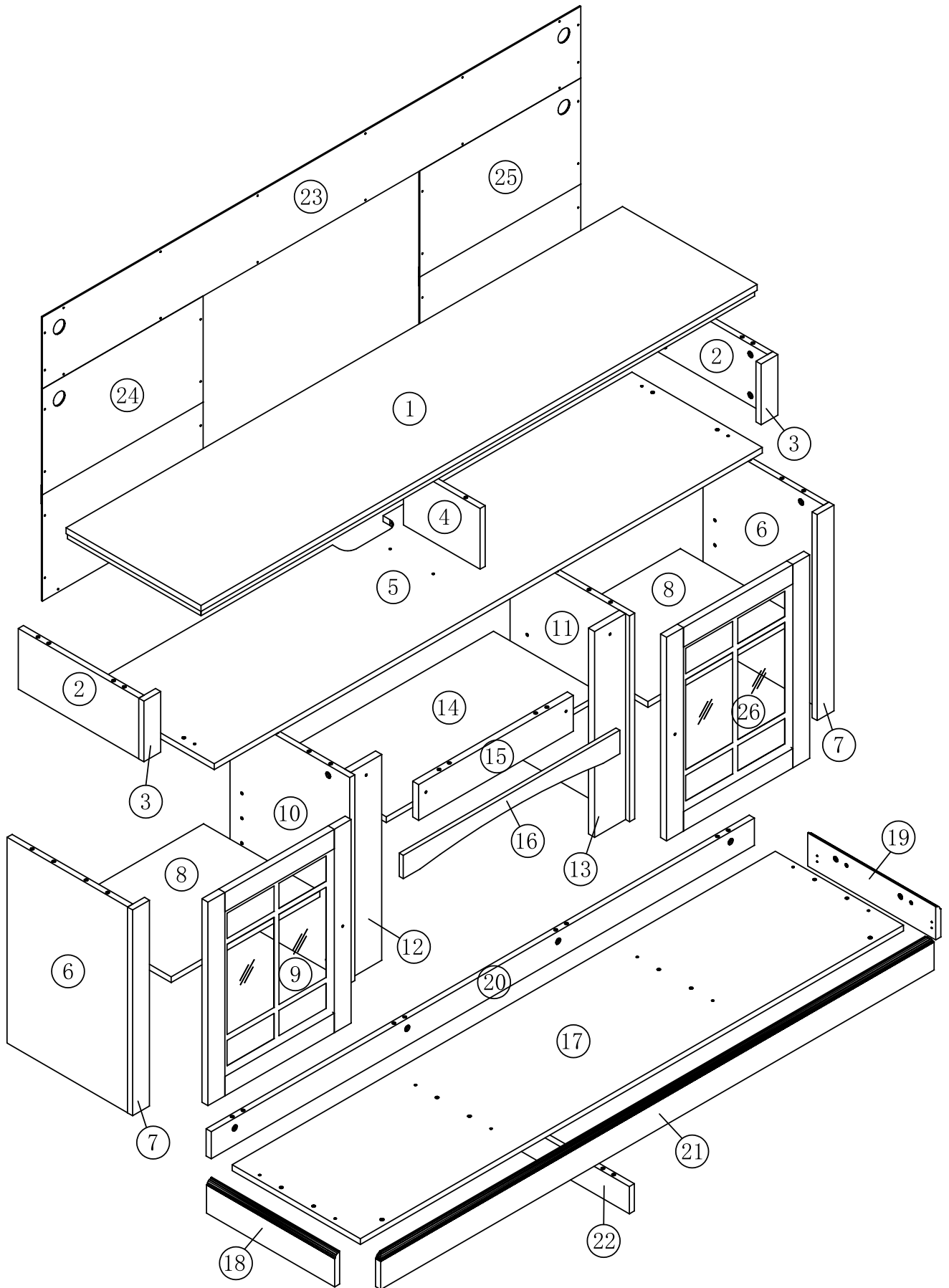



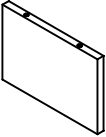
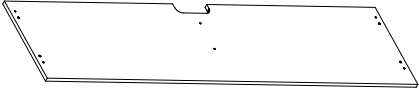

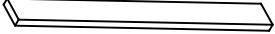
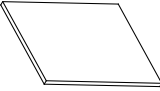
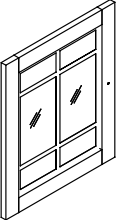
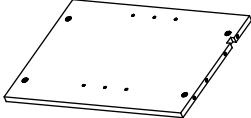
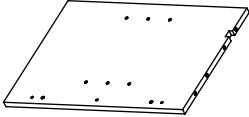

FTLFTS-6095

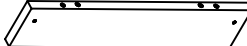
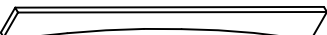







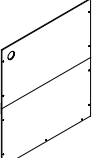
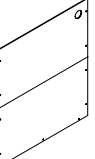
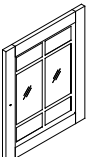



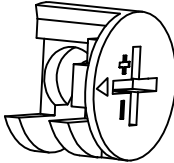

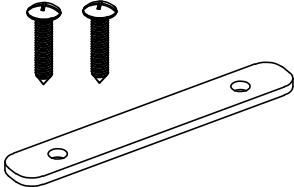
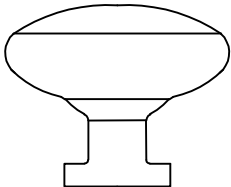
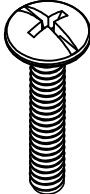
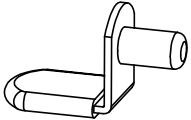
IMPORTANT.RETAIN FOR FUTURE REFERENCE: READ CAREFULLY

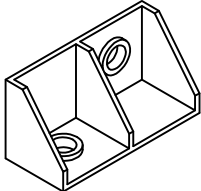

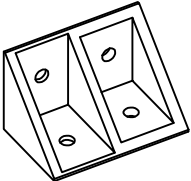
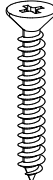
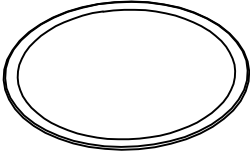
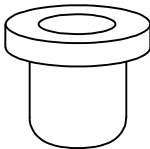
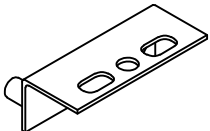
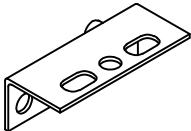
CODR	DESCRIPTION	QTY
1		1
2		2
3		2
4		1
5		1
6		2
7		2
8		2
9		1
10		1
11		1

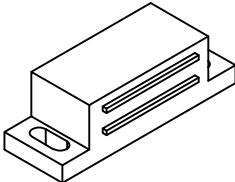
CODR	DESCRIPTION	QTY
12		1
13		1
14		1
15		1
16		1
17		1
18		1
19		1
20		1
21		1
22		1
23		1
24		1
25		1
26		1

<p>(A)</p>  <p>52X+3X</p>	<p>(B)</p> <p><math>\phi 8 \times 30 \text{mm}</math></p>  <p>40X+2X</p>	<p>(C)</p> <p><math>\phi 15</math></p>  <p>52X+3X</p>	<p>(D)</p> <p><math>\phi 4 \times 16 \text{mm}</math></p>  <p>24X+2X</p>
<p>(E)</p>  <p>4X</p>	<p>(F)</p>  <p>2X</p>	<p>(G)</p> <p>M4*22mm</p>  <p>2X</p>	<p>(H)</p>  <p>12X</p>
<p>(I)</p> <p><math>\phi 3.5 \times 12 \text{mm}</math></p>  <p>38X+2X</p>	<p>(J)</p>  <p>8X</p>	<p>(K)</p> <p>M6*12mm</p>  <p>16X+1X</p>	<p>(L)</p>  <p>6X</p>
<p>(M)</p> <p><math>\phi 3.5 \times 25 \text{mm}</math></p>  <p>4X+1X</p>	<p>(N)</p>  <p>46X</p>	<p>(O)</p>  <p>4X</p>	<p>(P)</p>  <p>2X</p>
<p>(Q)</p>  <p>2X</p>	<p>(R)</p> <p><math>\phi 3.5 \times 14 \text{mm}</math></p>  <p>8X</p>	<p>(S)</p>  <p>2X</p>	<p>(T)</p> <p><math>\phi 3 \times 16 \text{mm}</math></p>  <p>4X</p>

U

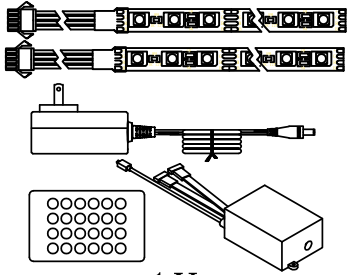

1X

V

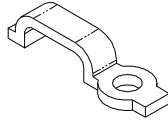

8X

W

$\phi 3.0 * 12\text{mm}$



10X+1X

X

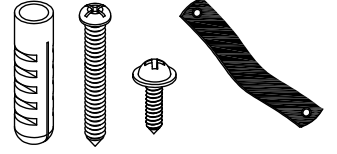

2X

# Step 1

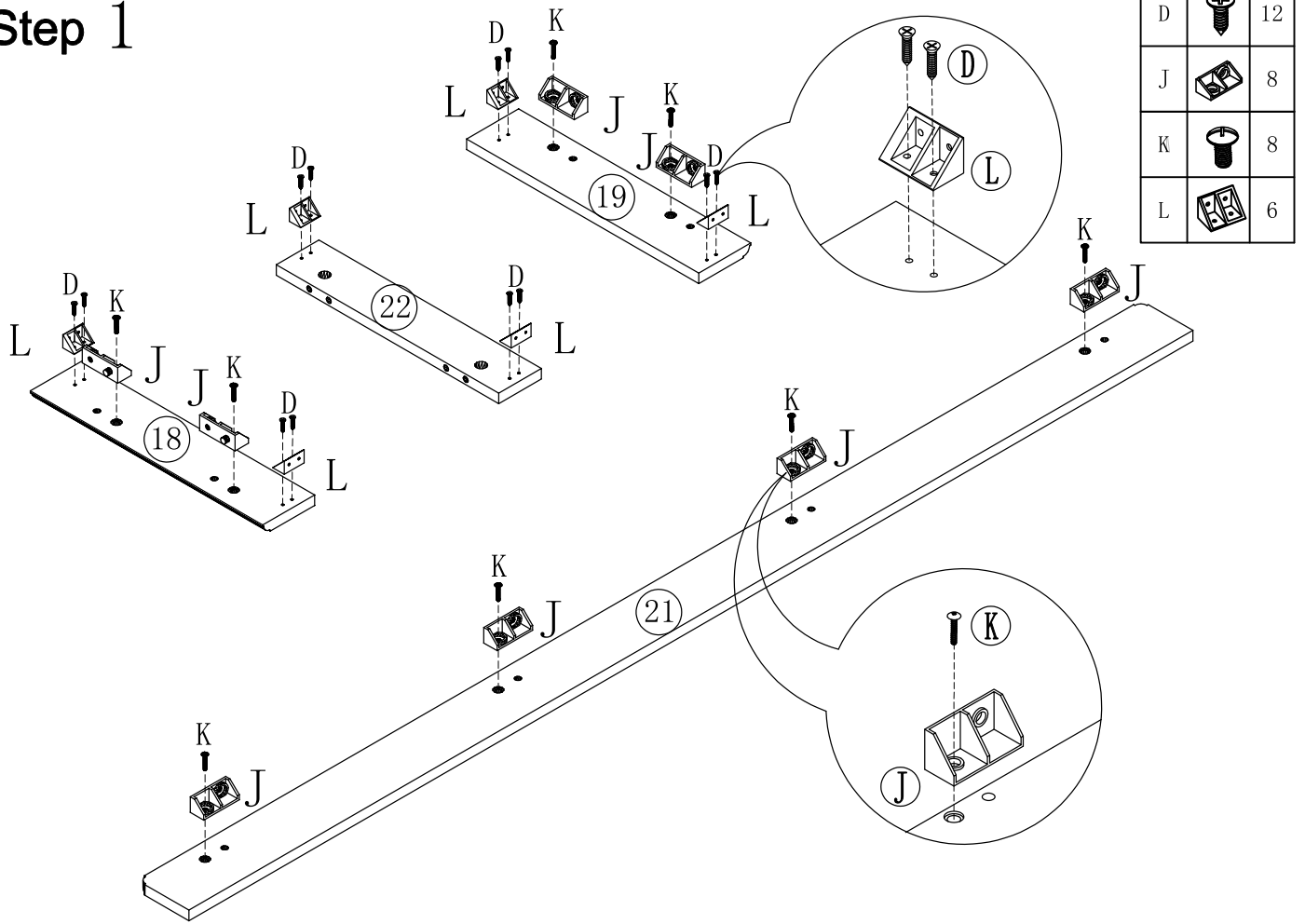

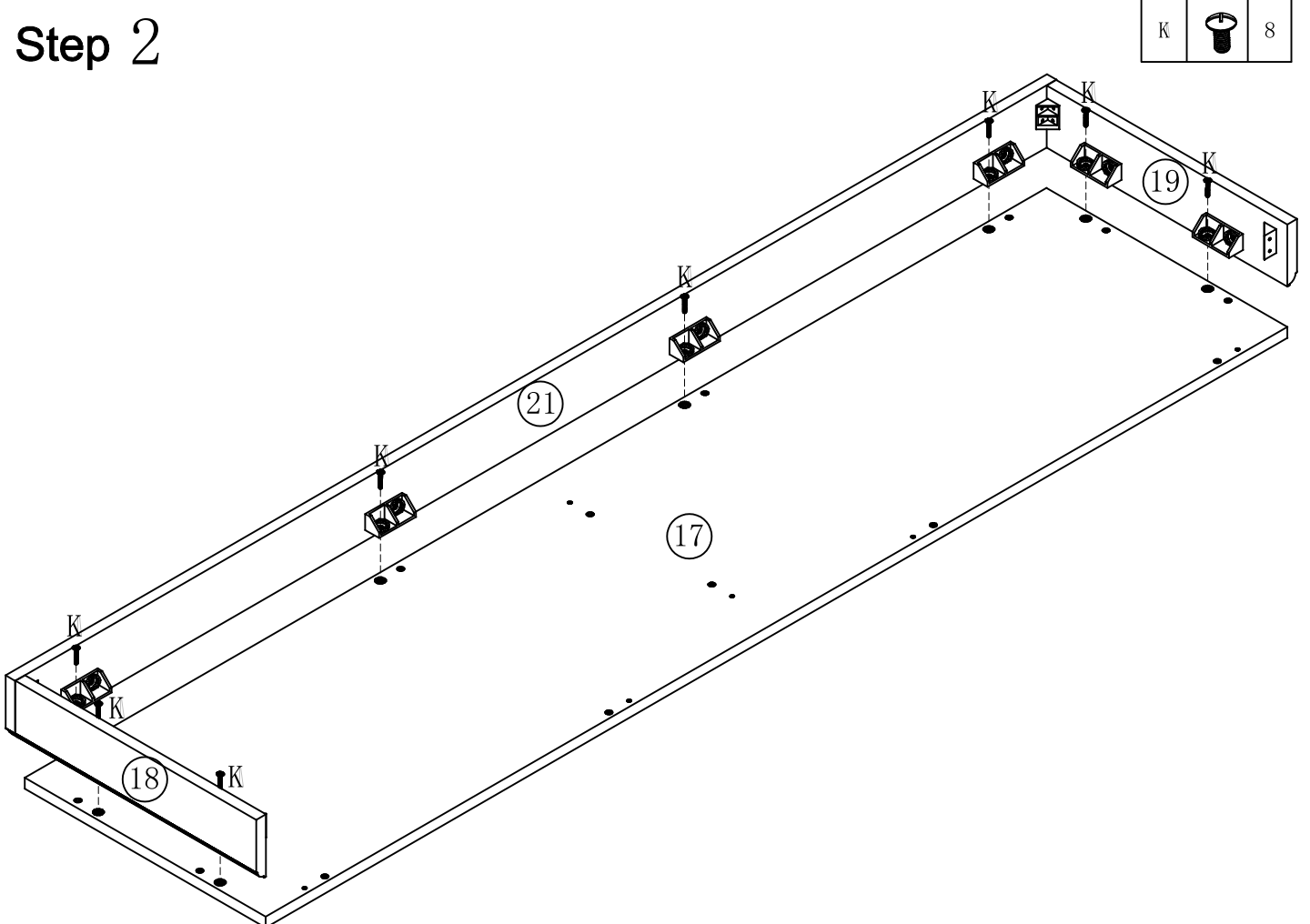

D		12
J		8
K		8
L		6

# Step 2



K		8
---	--	---

# Step 3

A		6
B		6

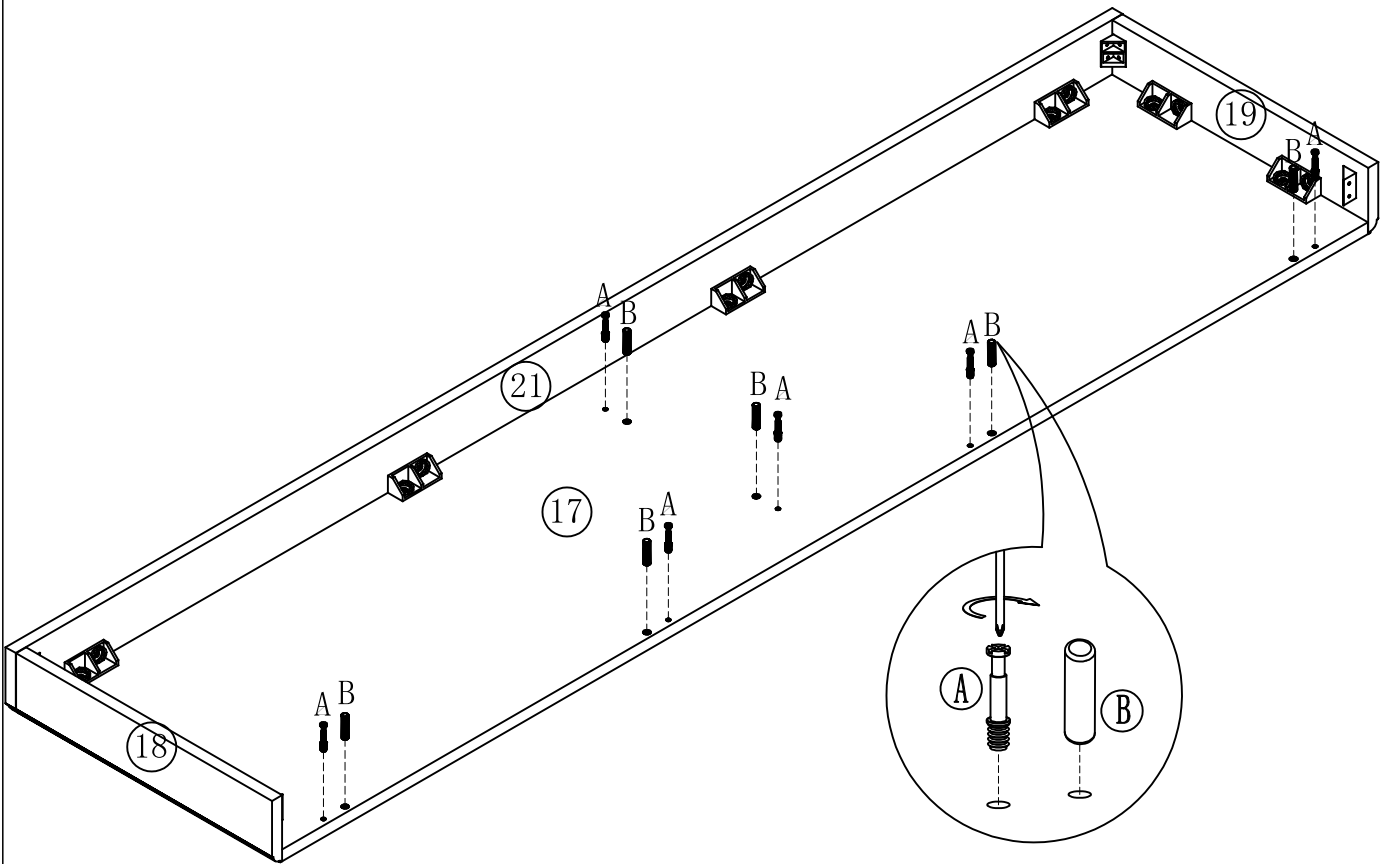

# Step 4

C		6
---	---	---

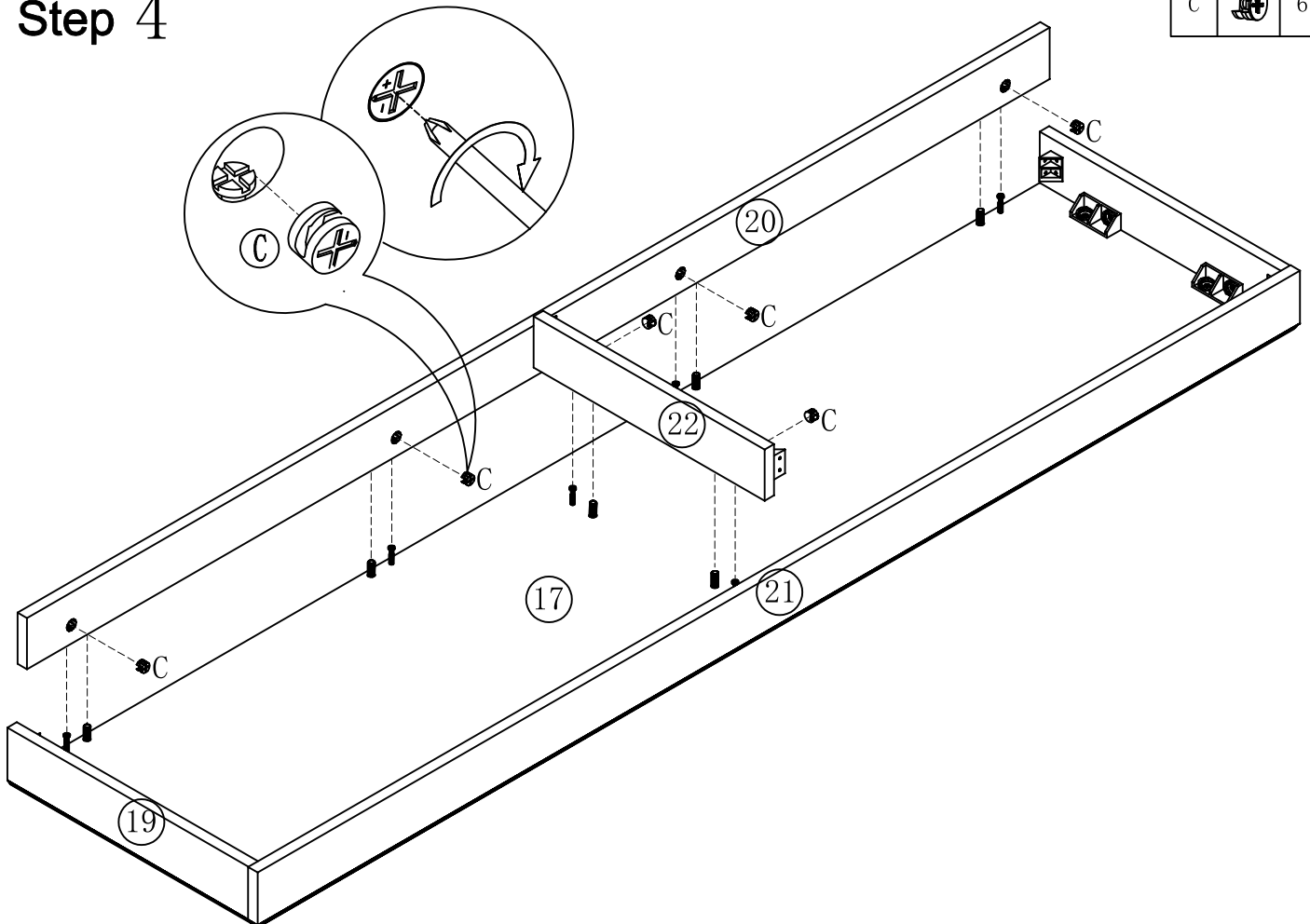

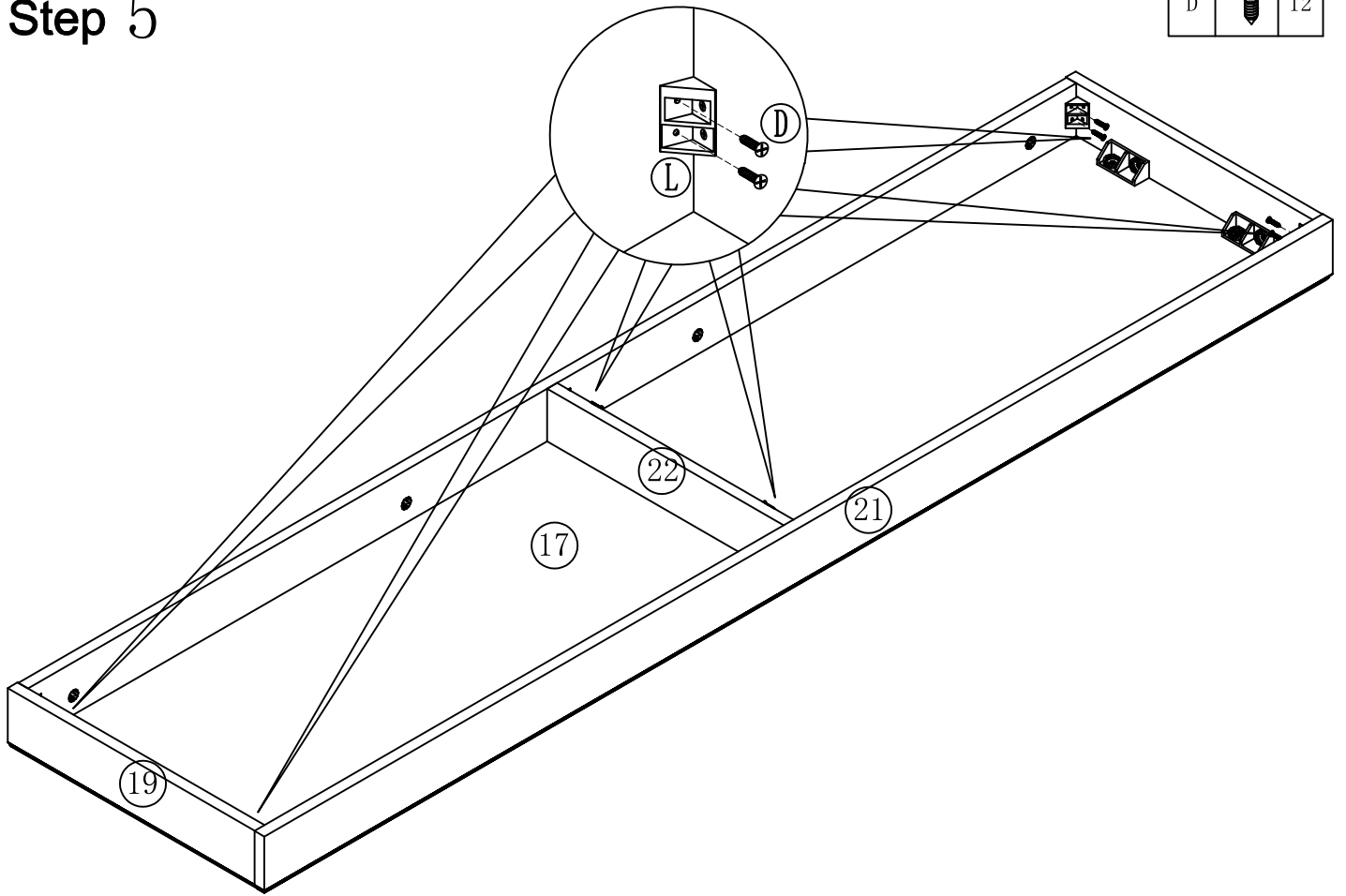

# Step 5

D		12
---	--	----



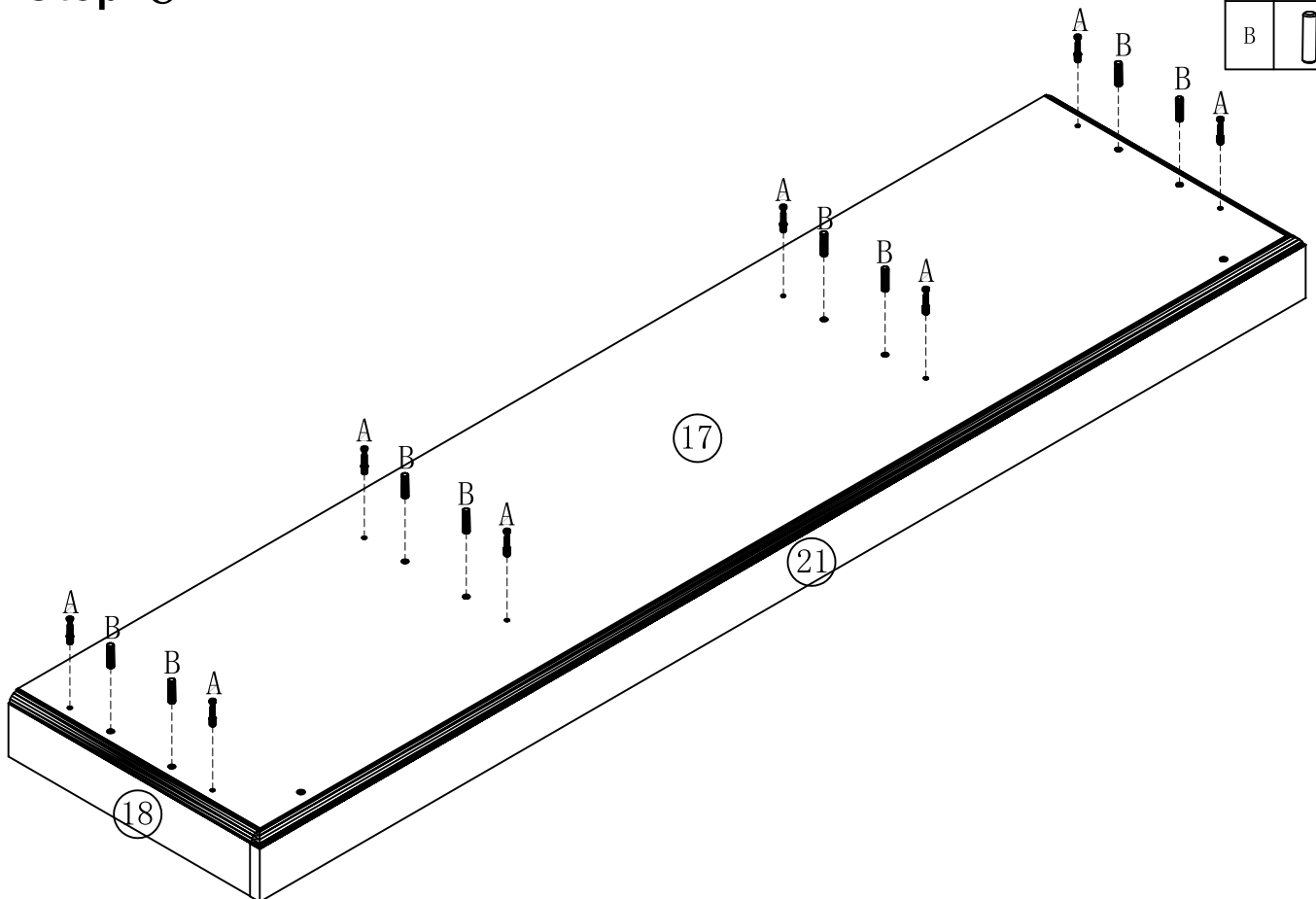

# Step 6

A		8
B		8



# Step 7

A		6
B		4

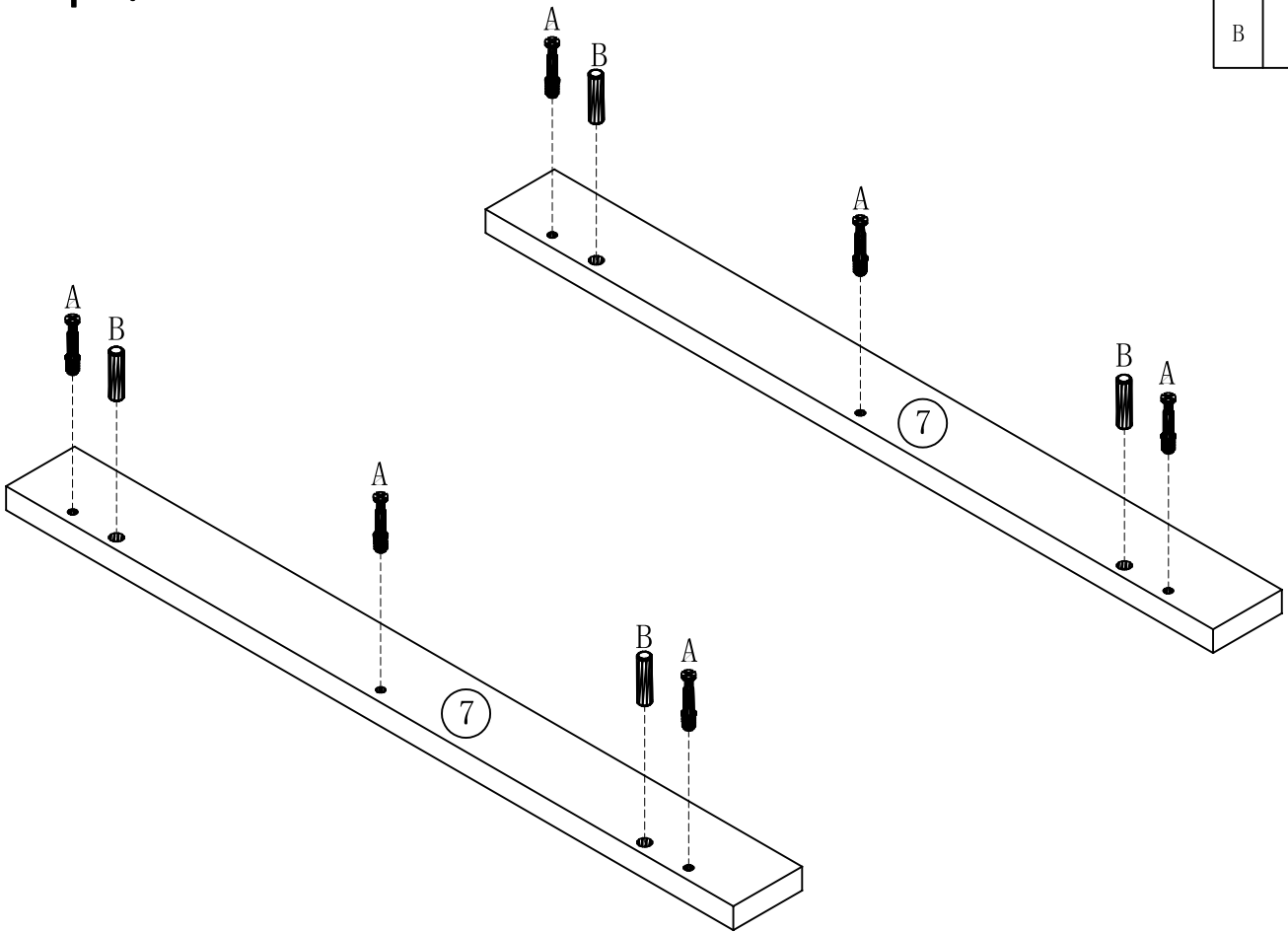

# Step 8

C		6
---	---	---

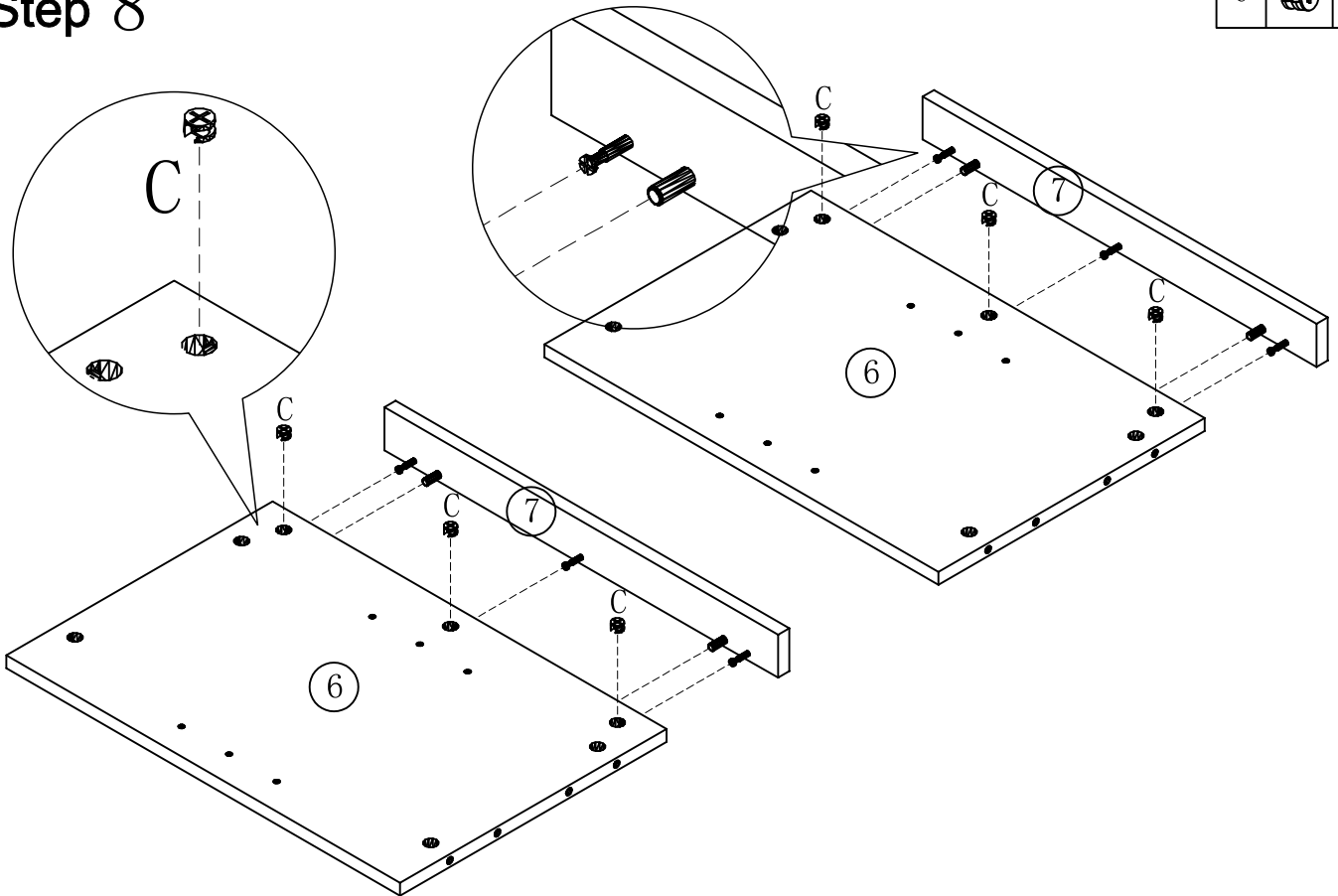

# Step 9

C		4
---	--	---

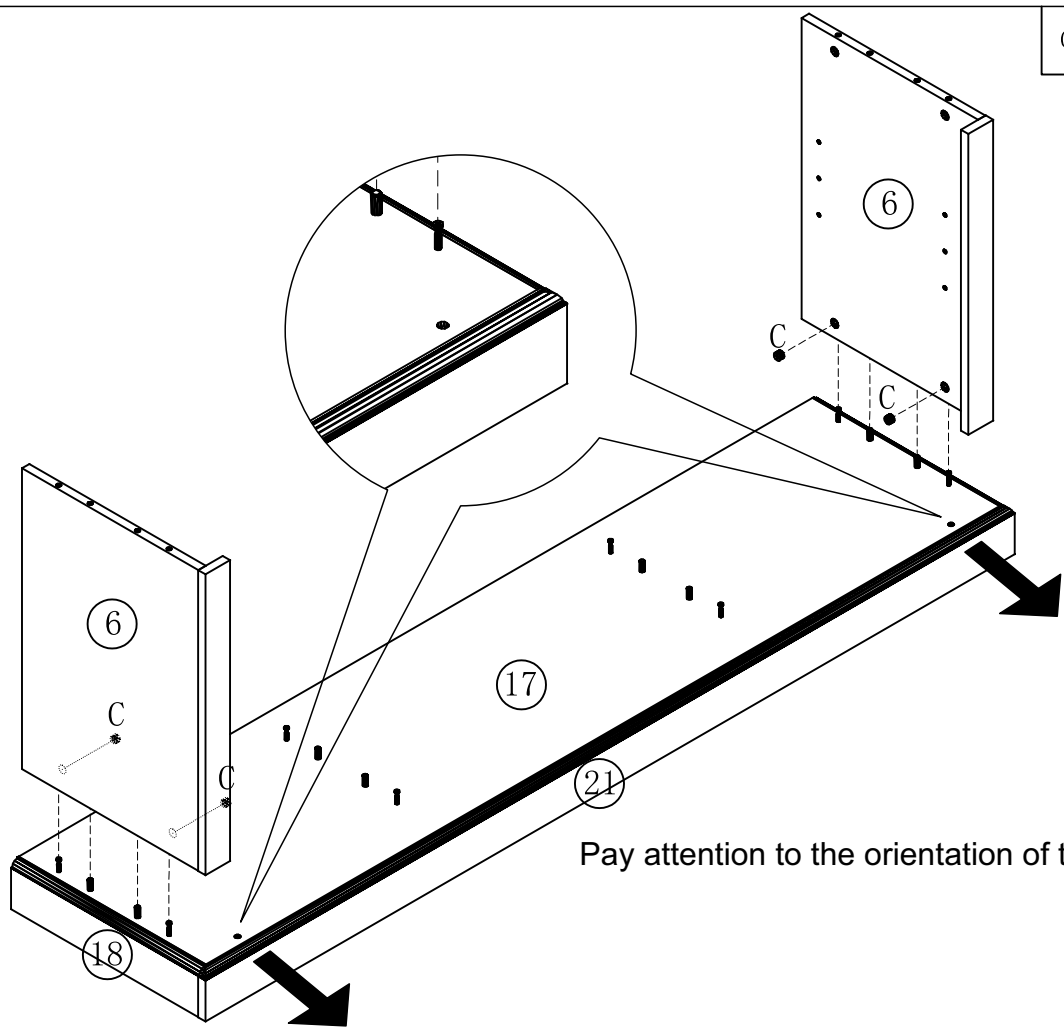



Pay attention to the orientation of the hole.

# Step 10

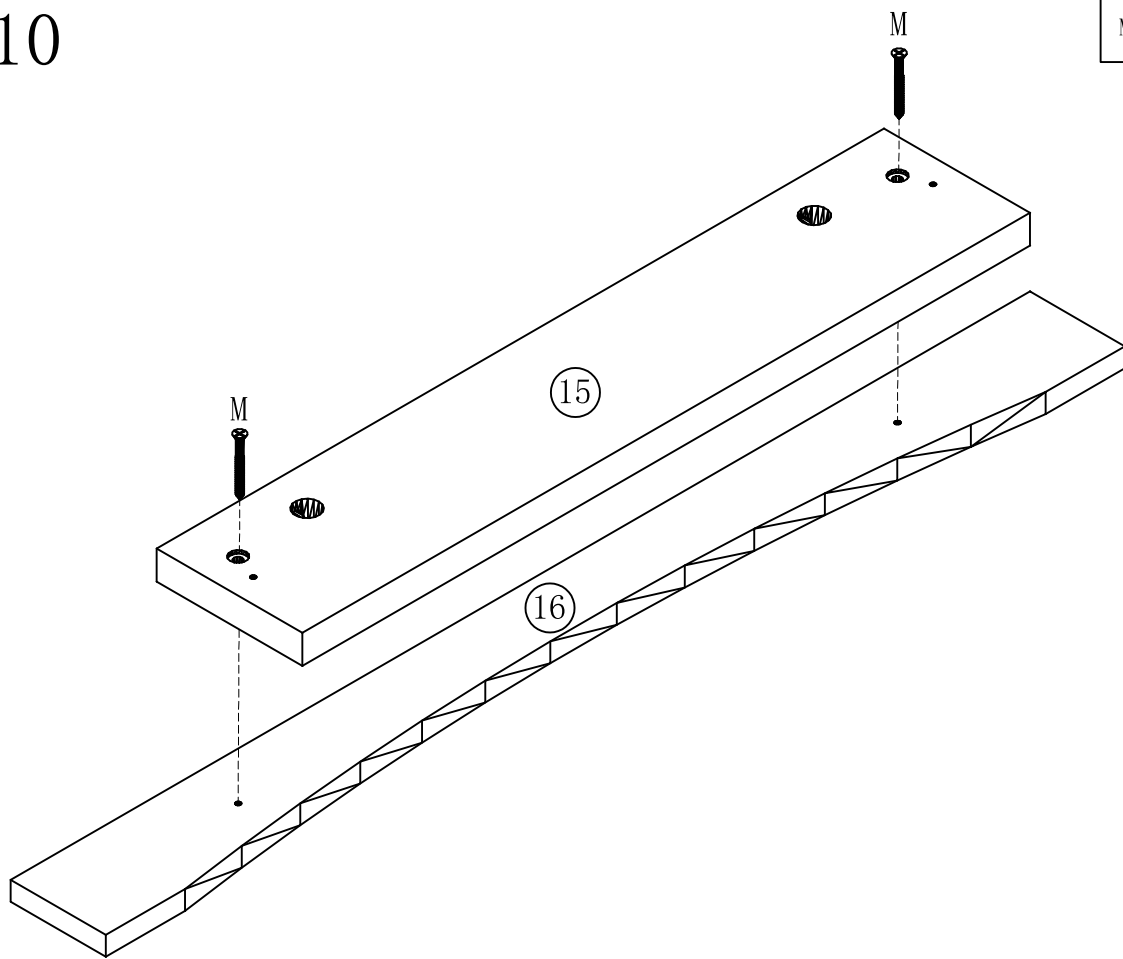
M		2
---	---	---





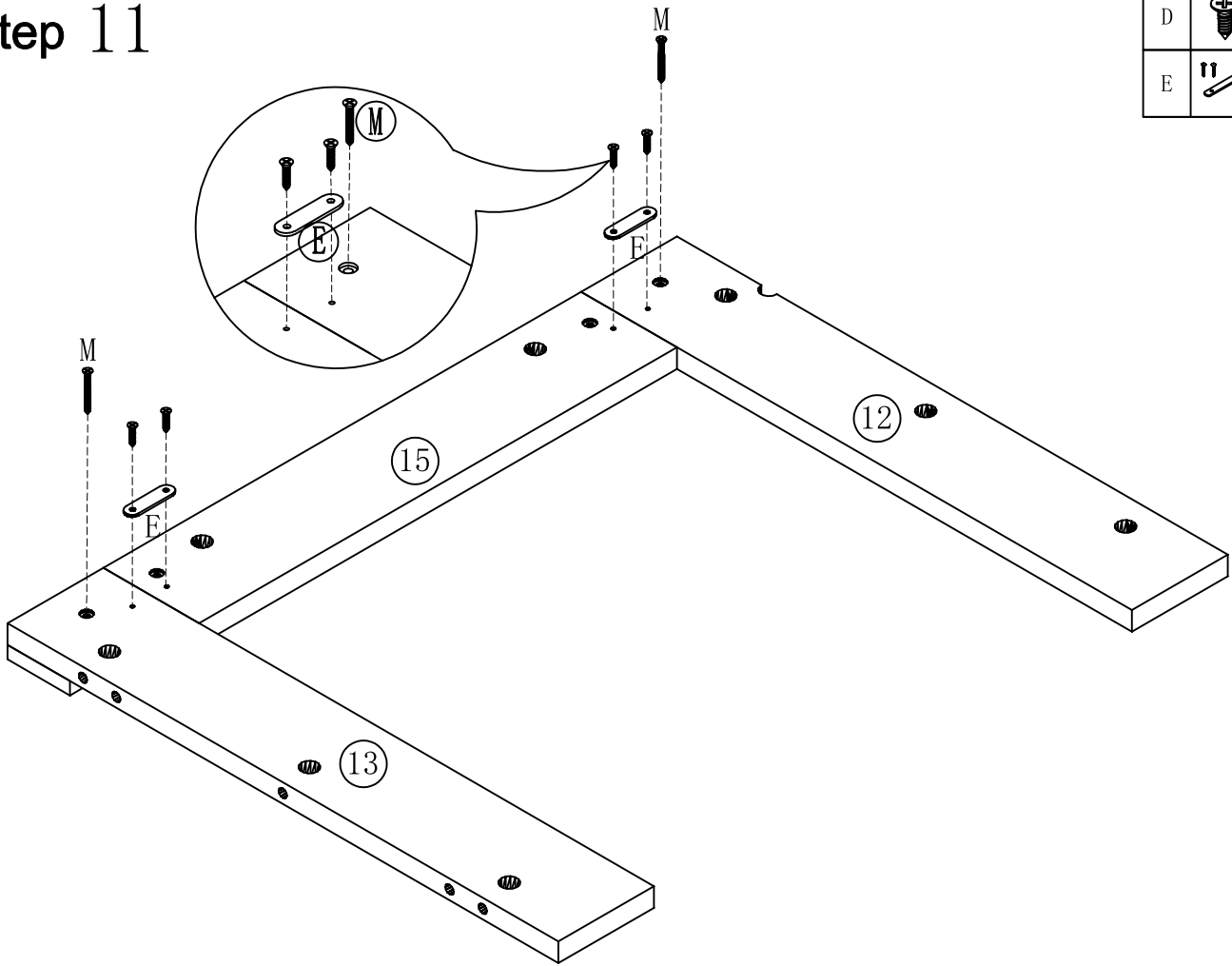

# Step 11

D		4
E		2



# Step 12

A		6
B		4
U		1
W		2

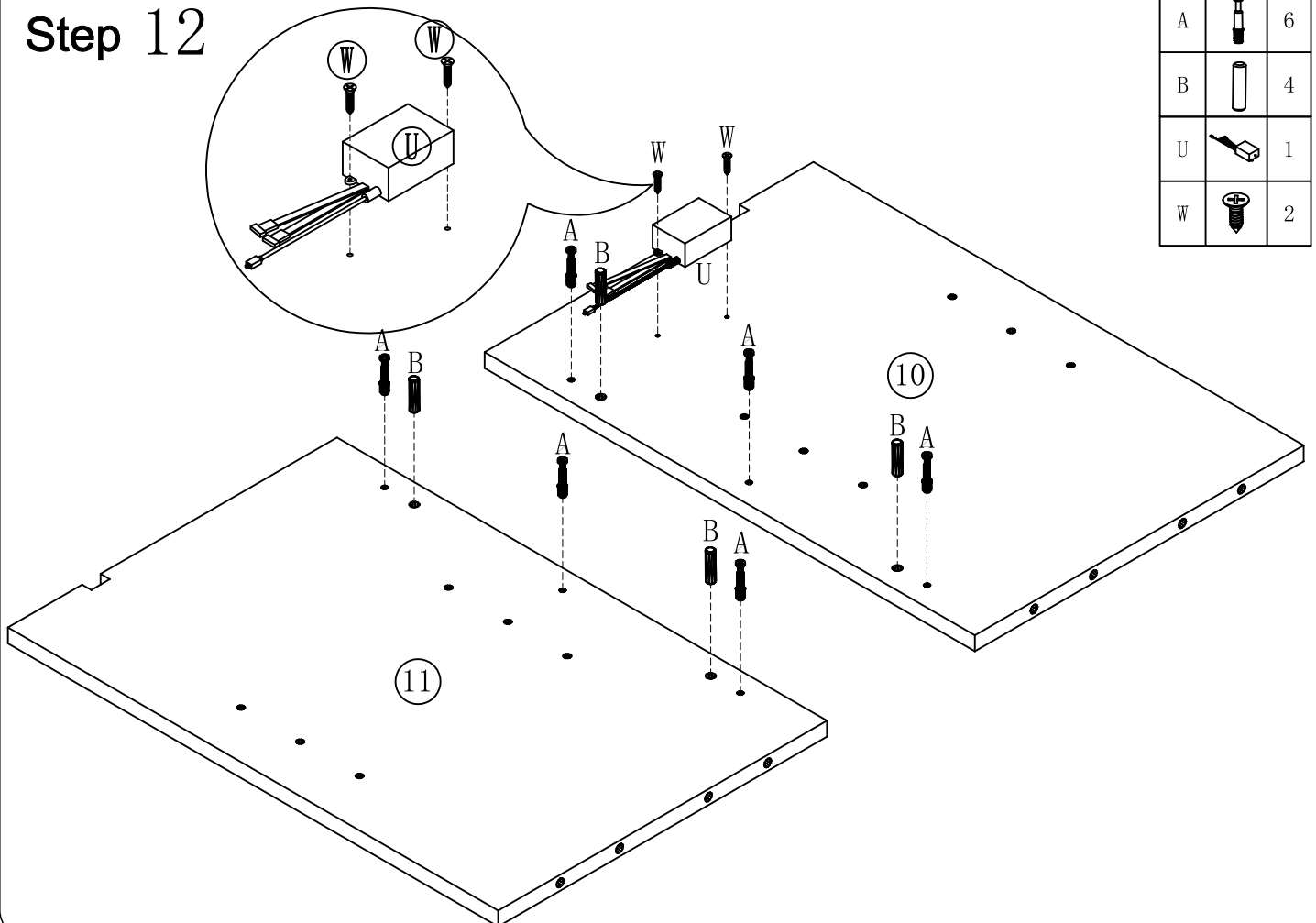



# Step 13

The infrared sensor "U" must pass through the hole of No.12 board, then the remote control will work normally

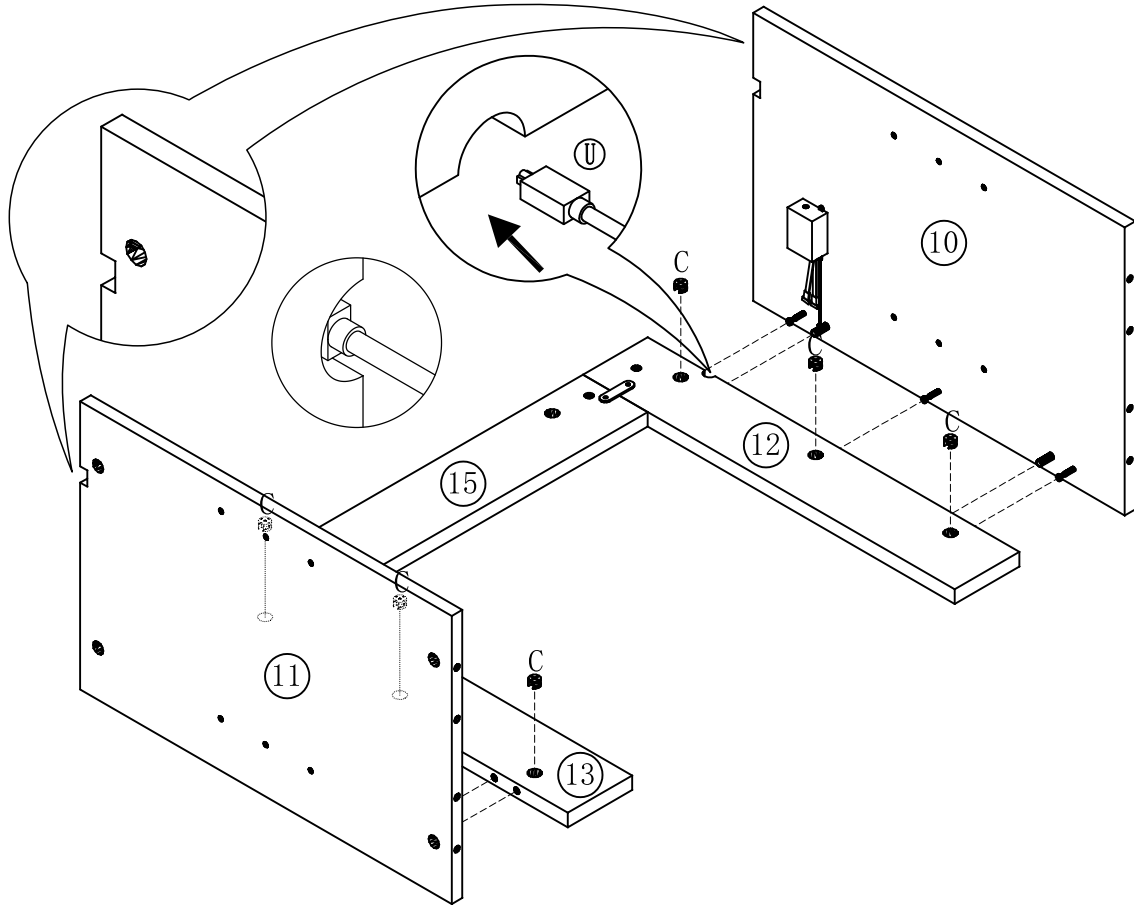
C		6
---	--	---



# Step 14

C		4
B		10

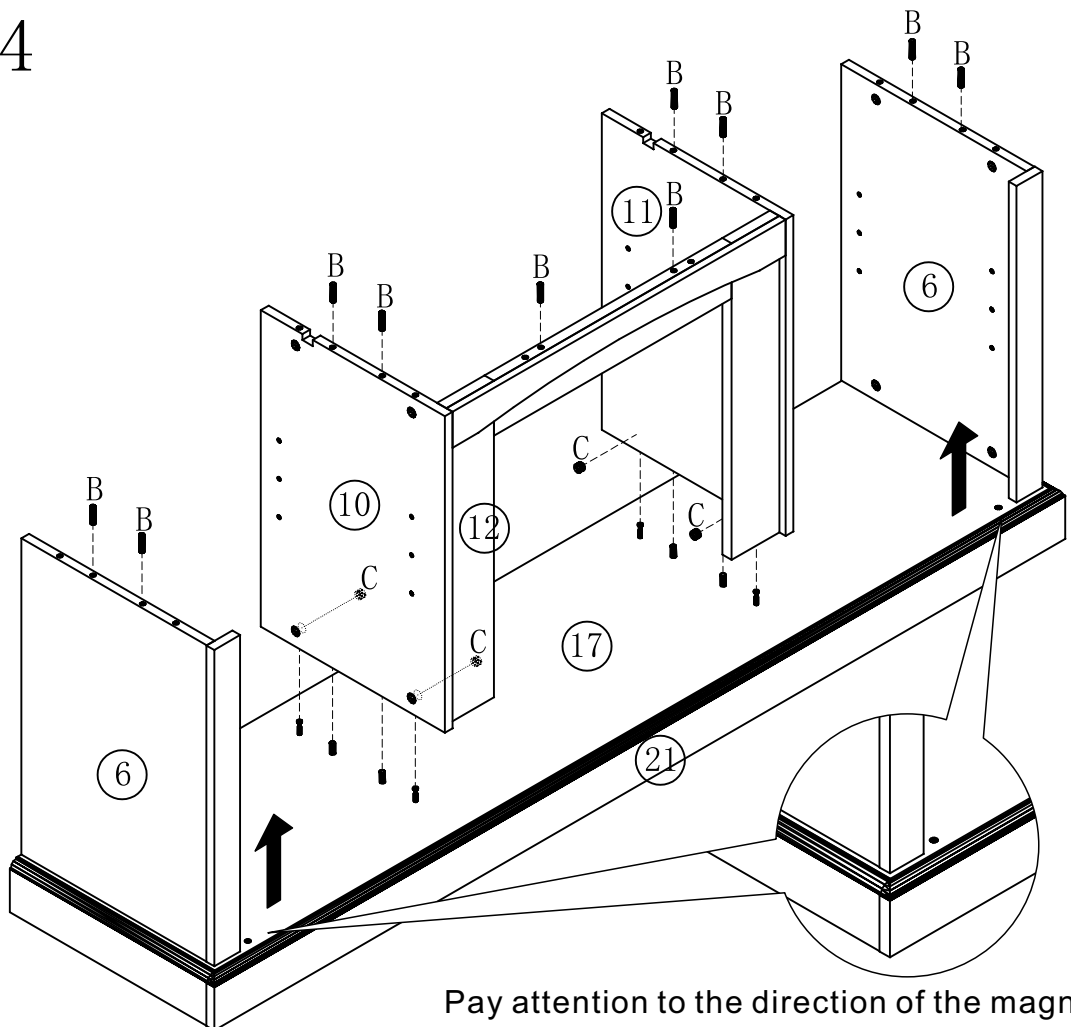

Pay attention to the direction of the magnet.

# Step 15

Tear off the tape and apply it to the plate, Then press it firmly with your hand

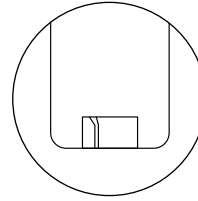
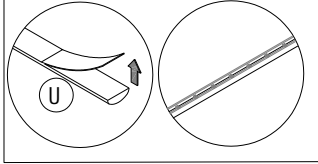

Remove the plastic piece before using the remote.

Please remove the plastic film here before using the remote control

U		1
V		4
W		4

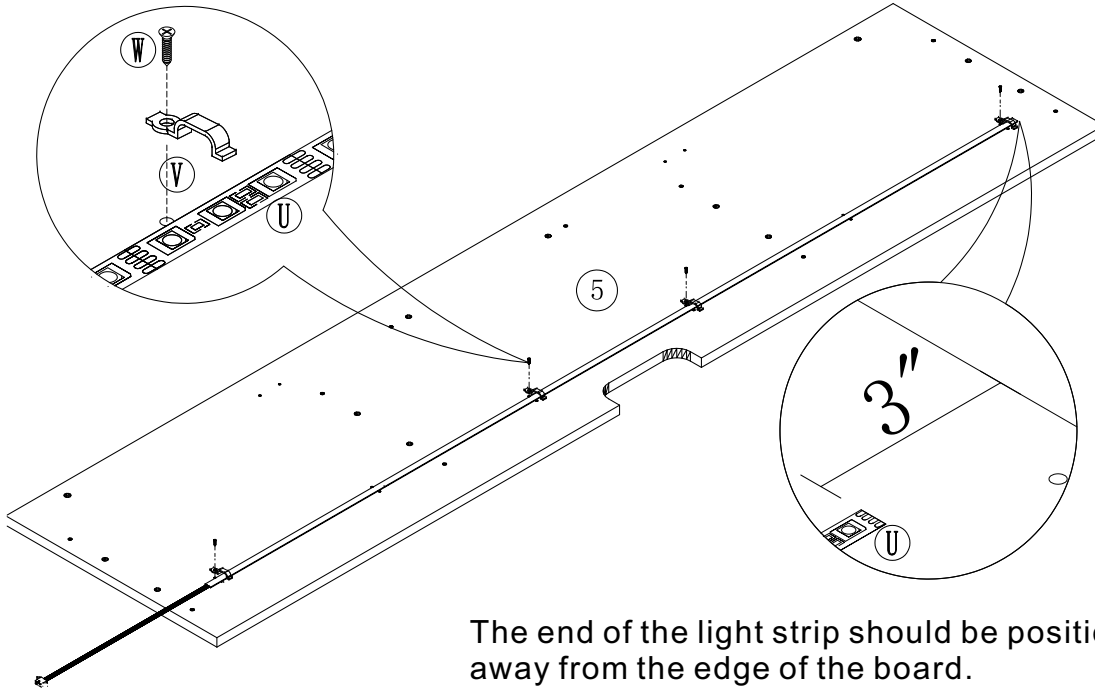

The end of the light strip should be positioned 3 inches away from the edge of the board.

# Step 16

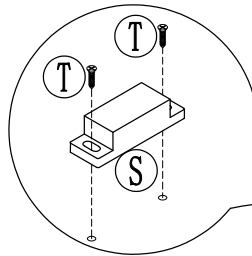

S		2
T		4

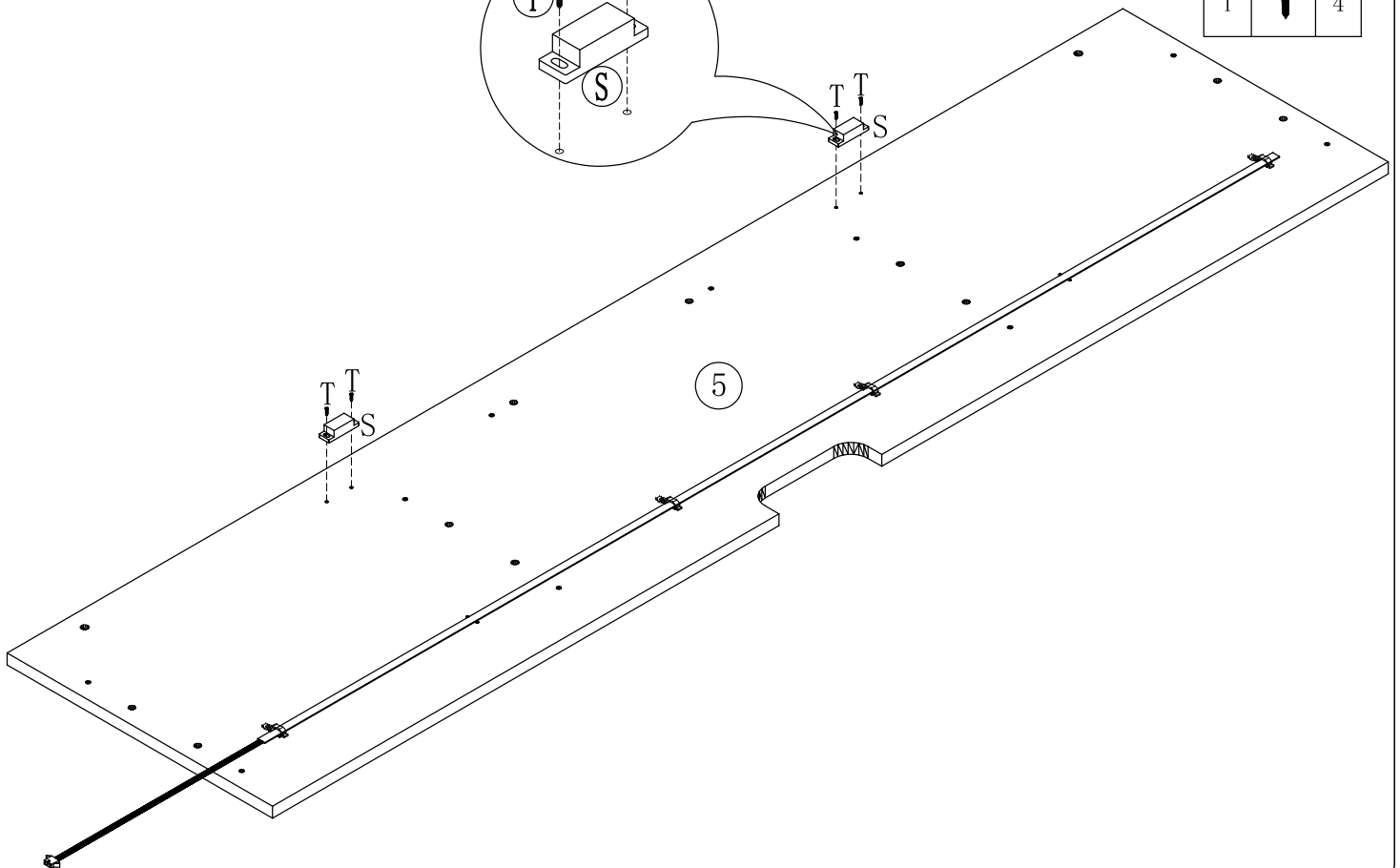

# Step 17

A		10
---	--	----

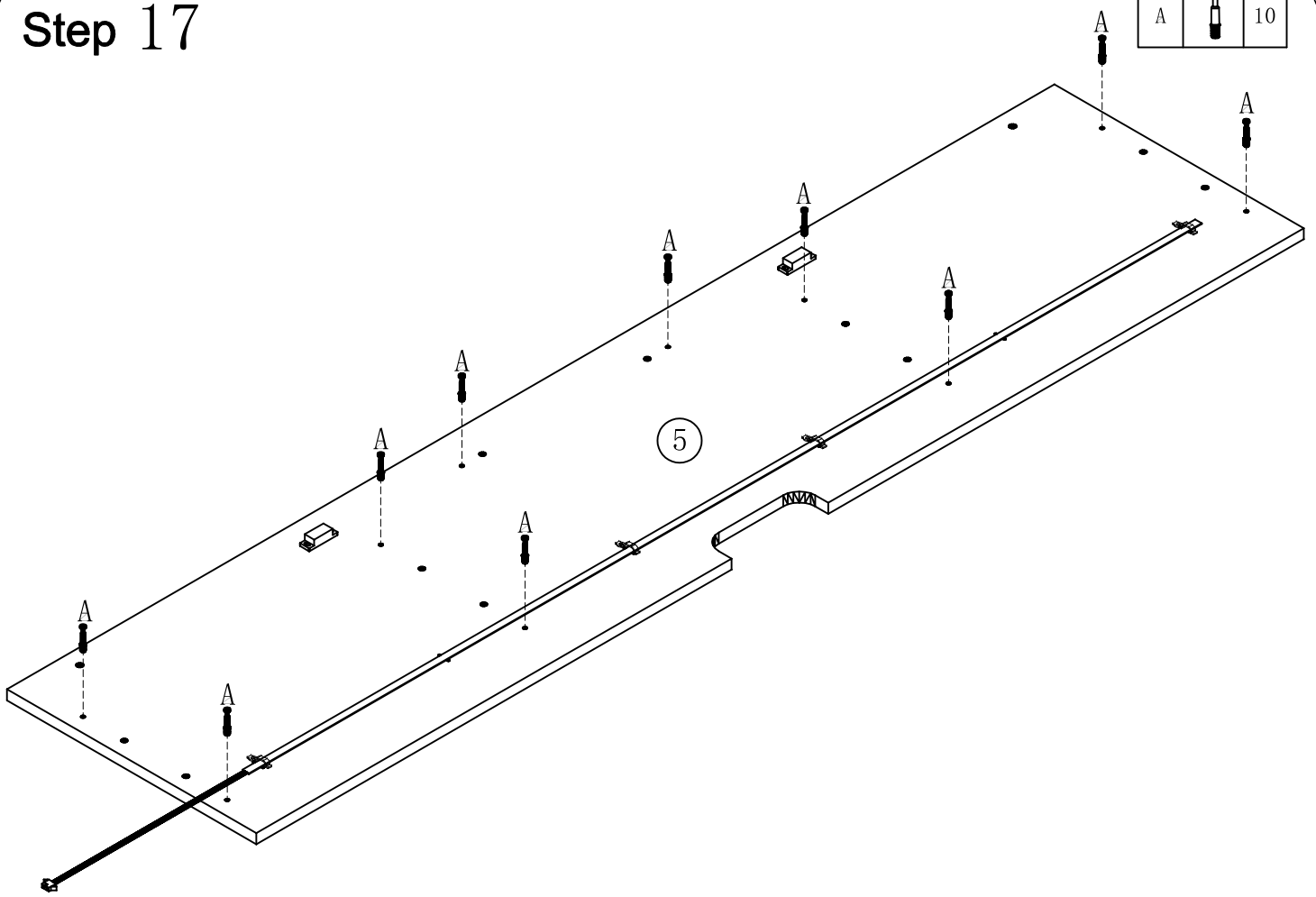

# Step 18

C		10
---	---	----

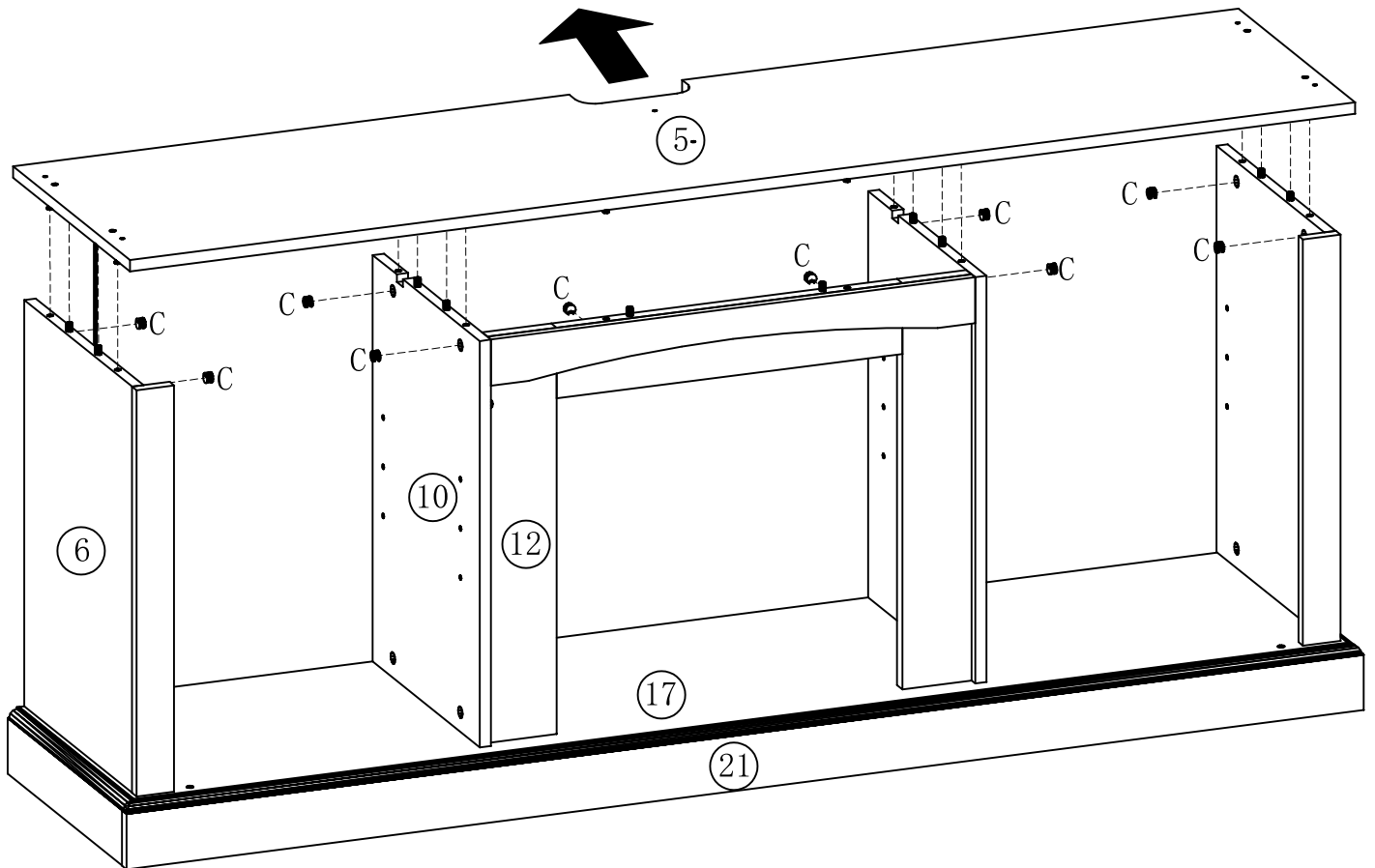

# Step 19

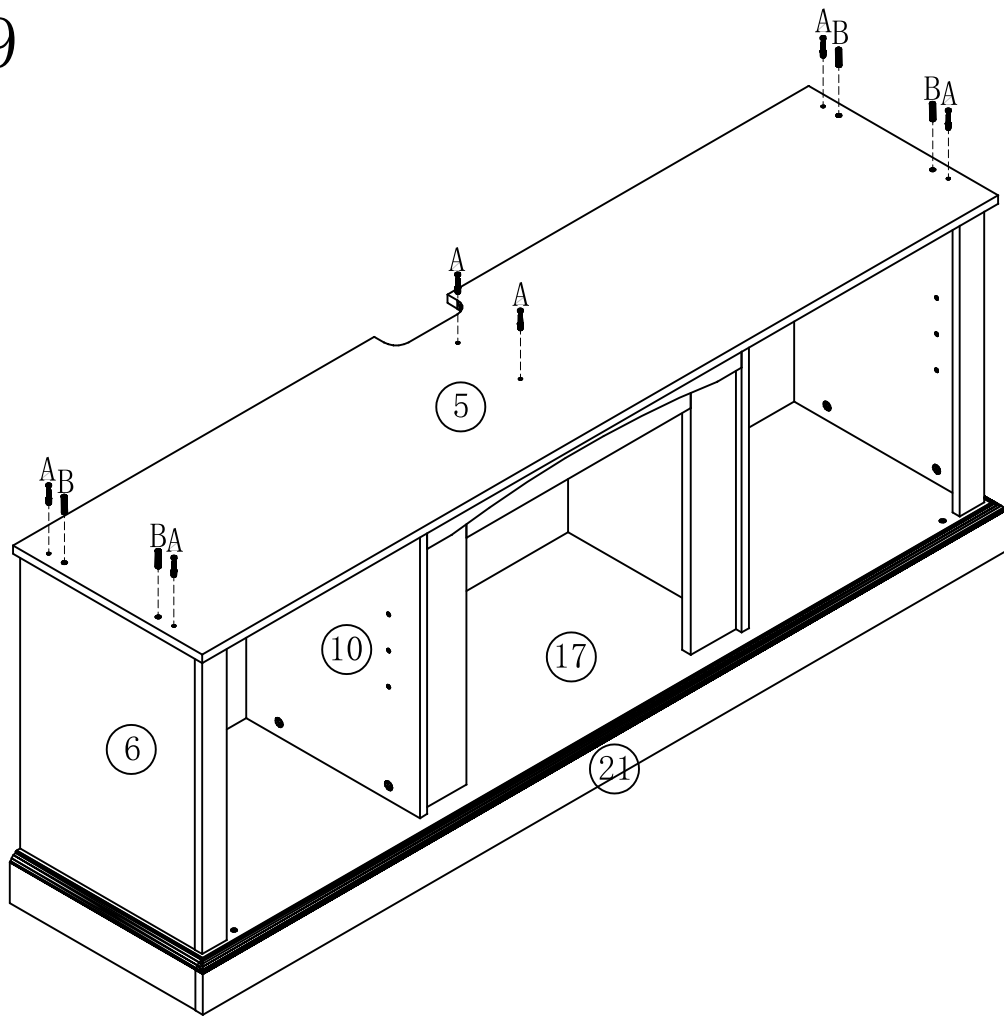

A		6
B		4

# Step 20

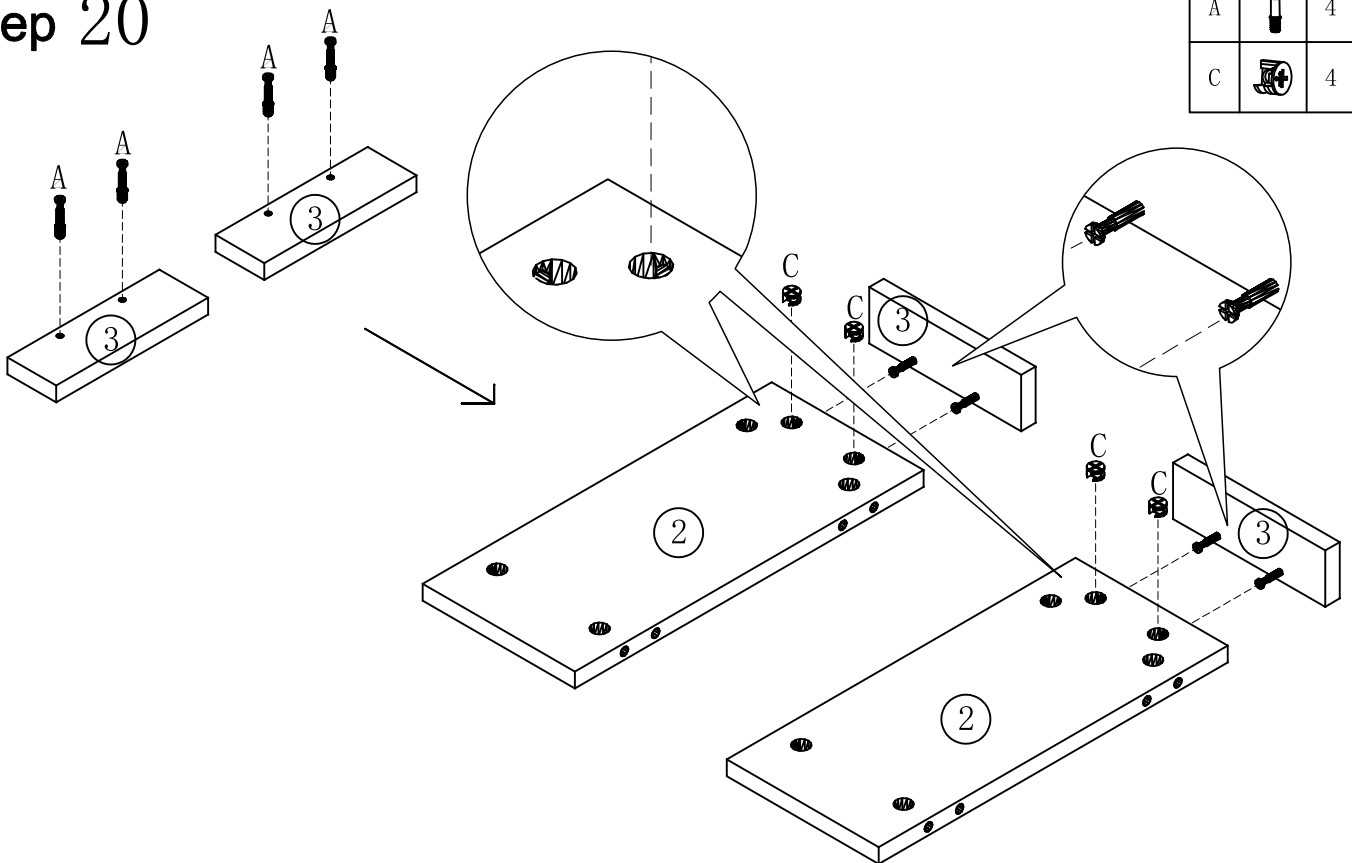

A		4
C		4

# Step 21

C		6
---	---	---

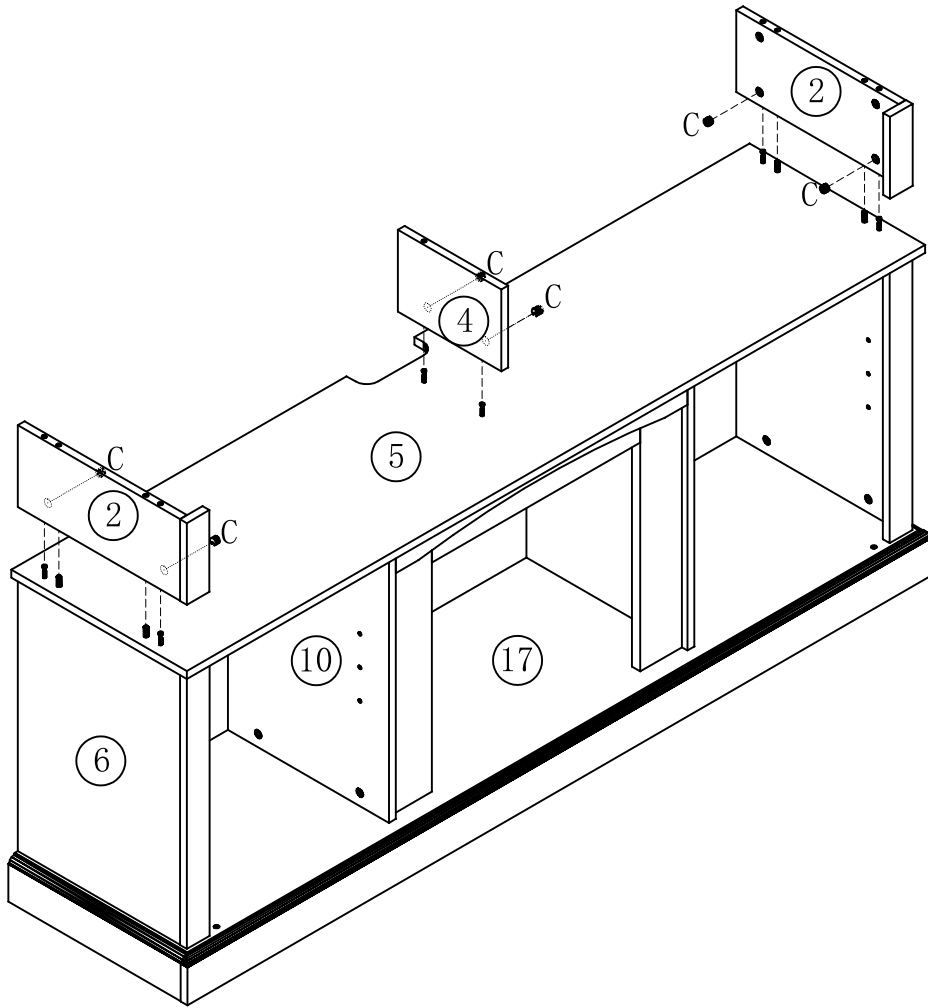

# Step 22

B		4
---	---	---

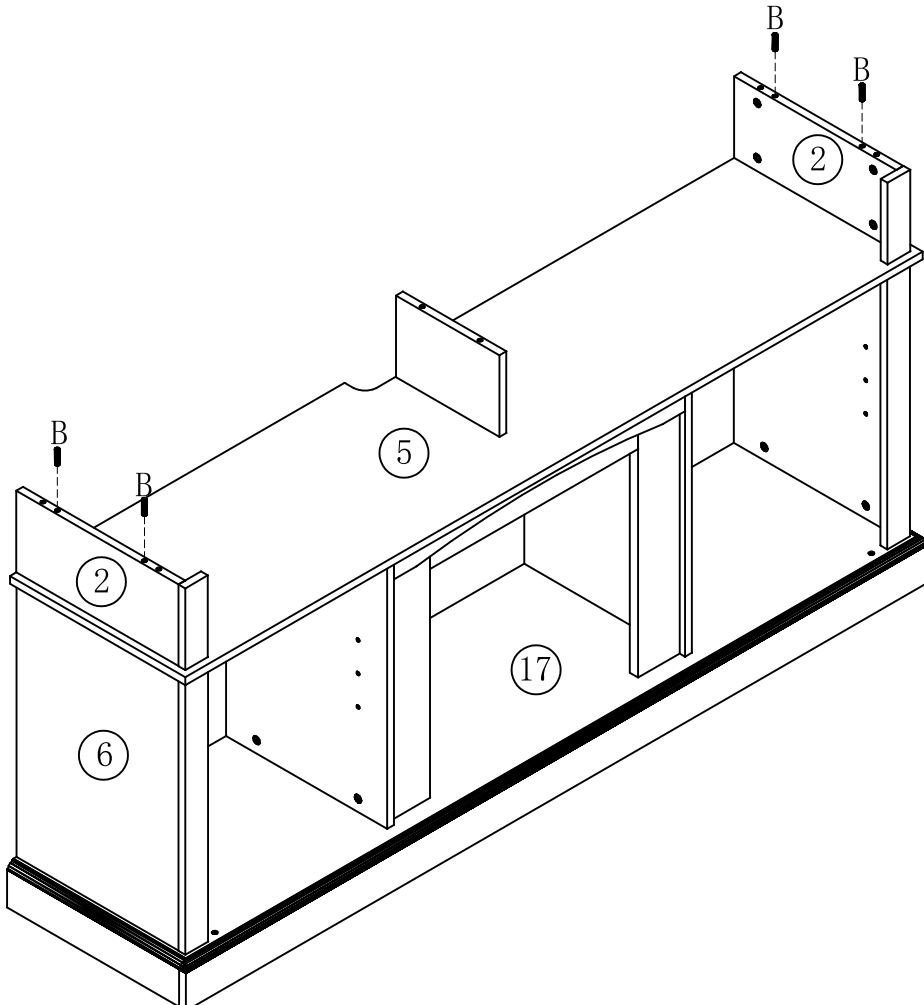

# Step 23

Remove the tape and apply it to the top, then press it firmly with your hand

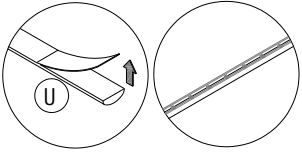

Remove the plastic piece before using the remote.

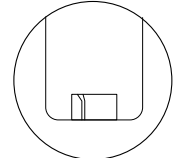

Please remove the plastic film here before using the remote control

A		6	U		1
V		4	W		4

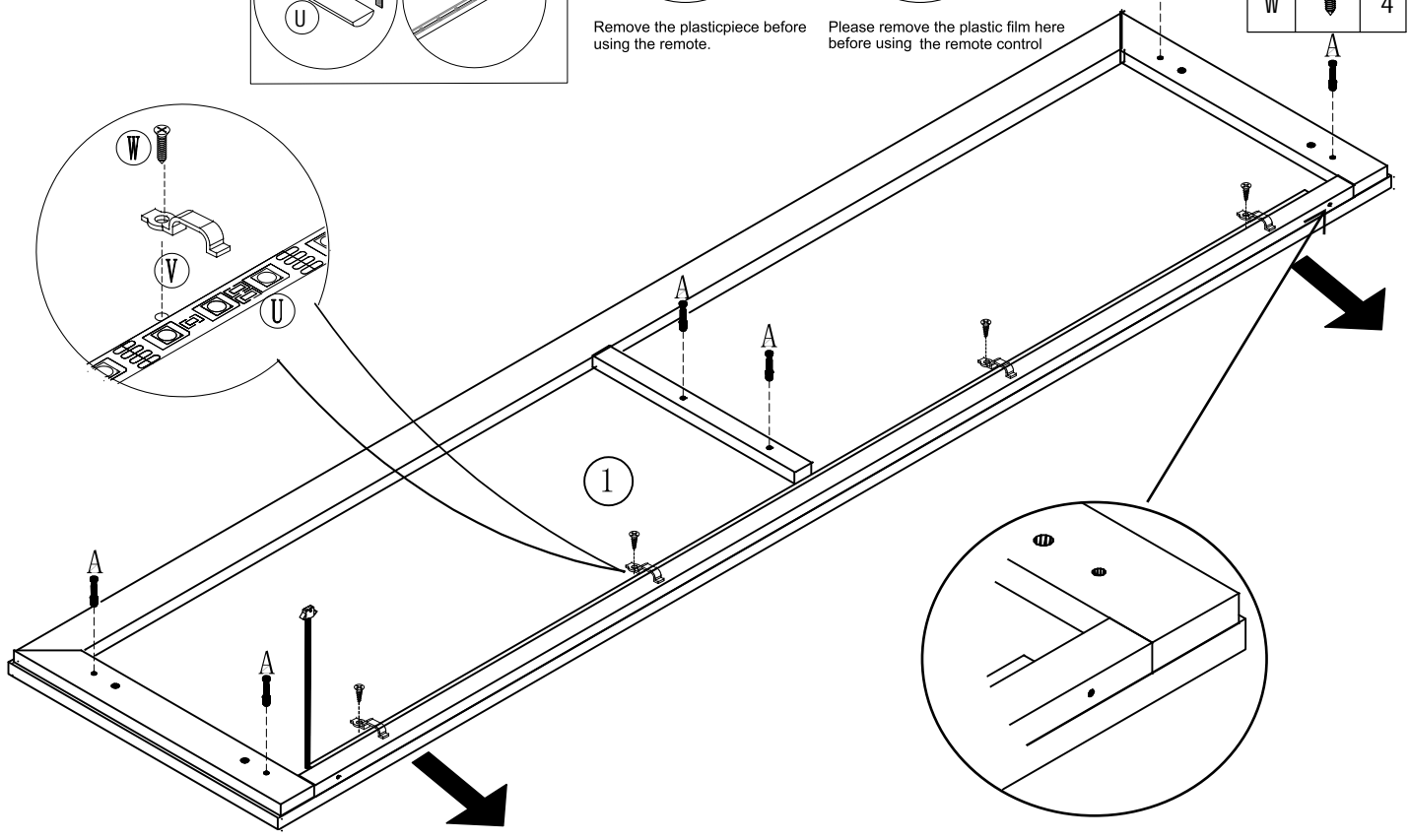

# Step 24

C		6
---	--	---

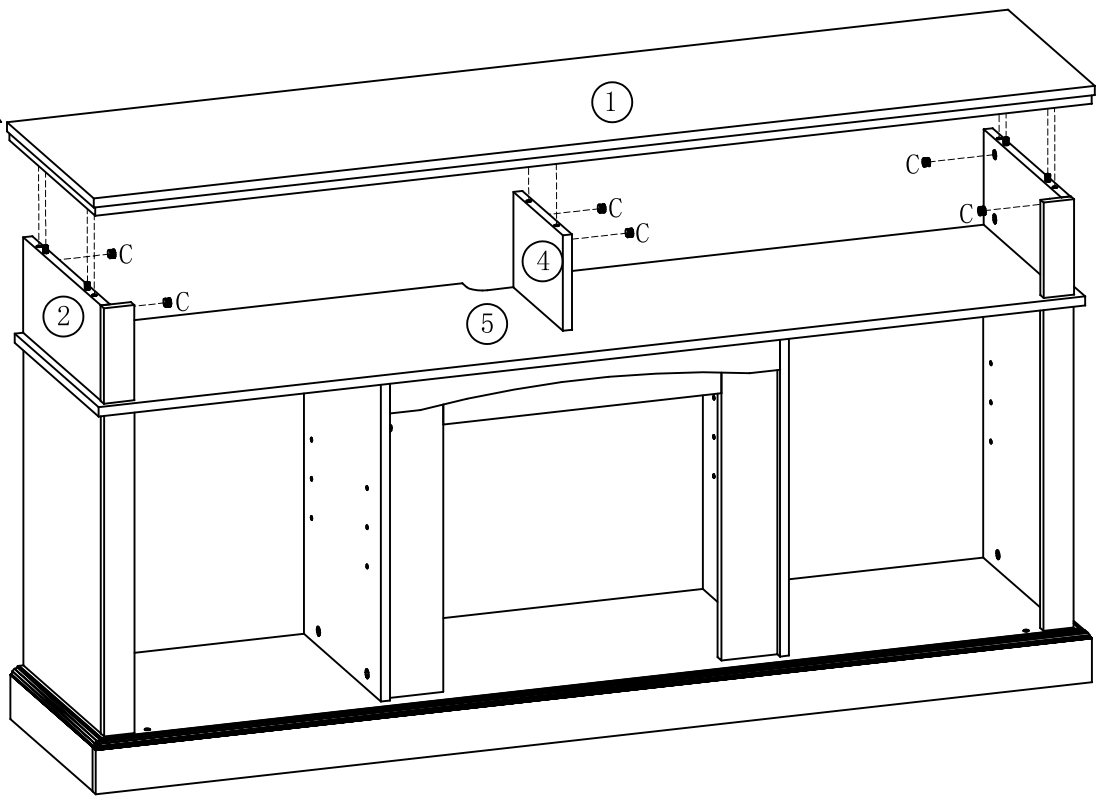
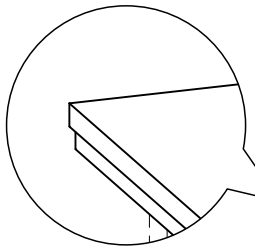

# Step 25

N		46
---	---	----

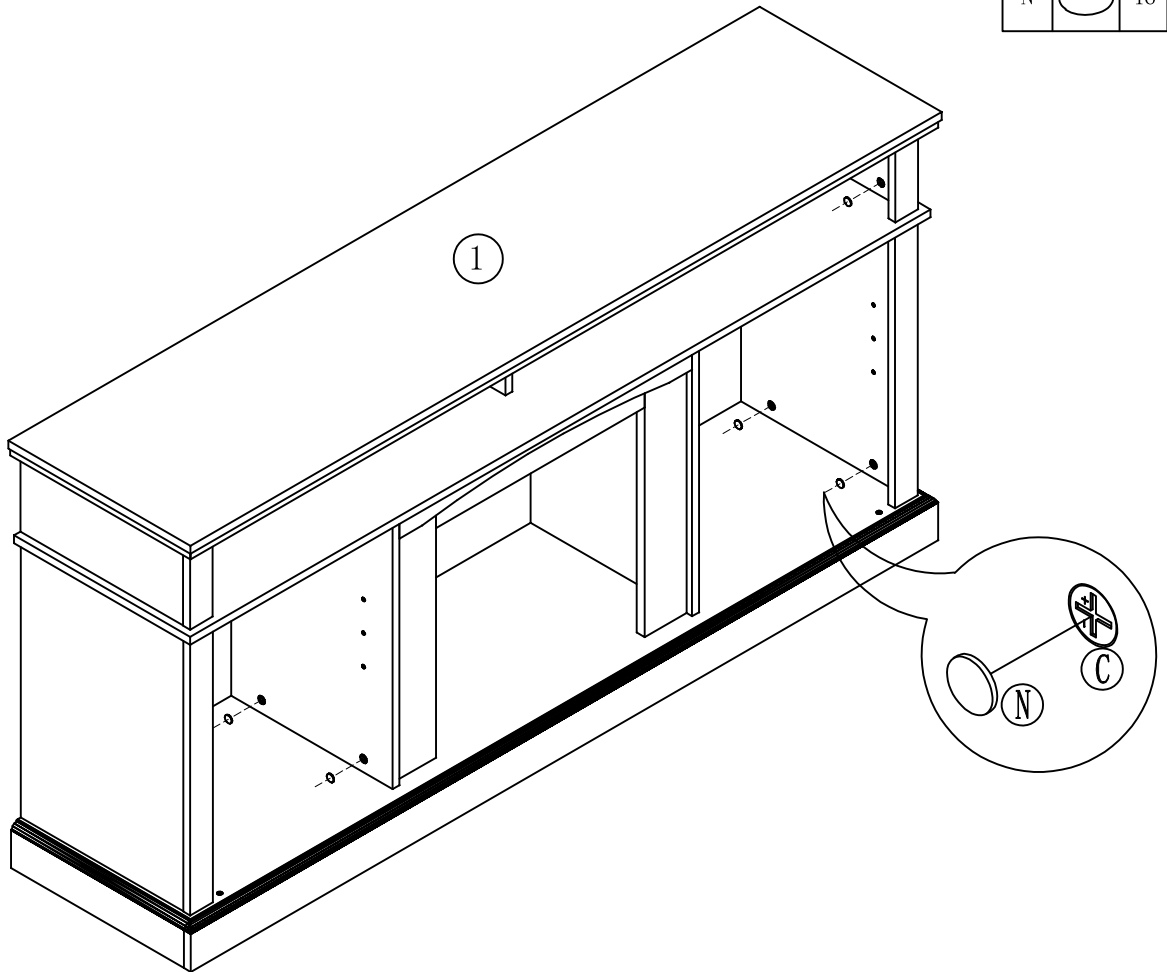

# Step 26

I		38
---	---	----

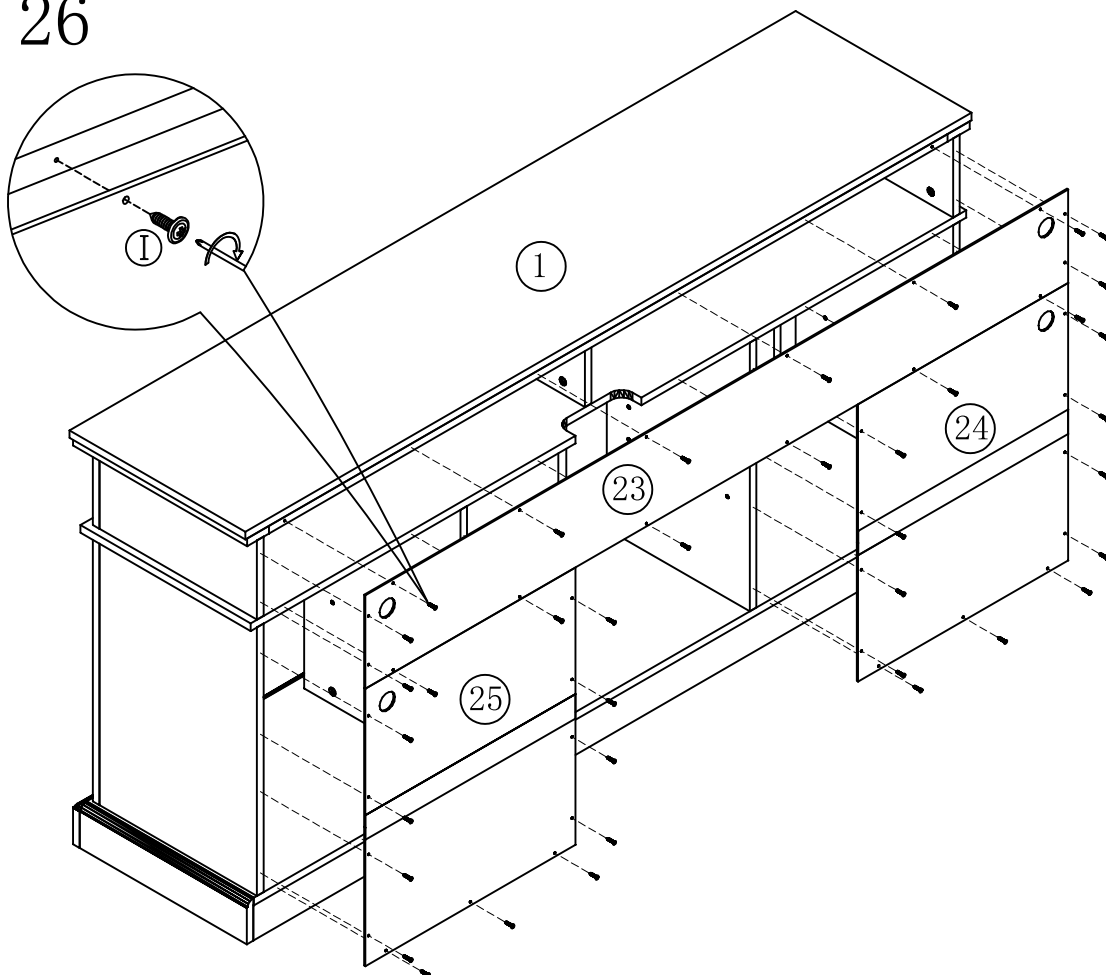

## Step 27

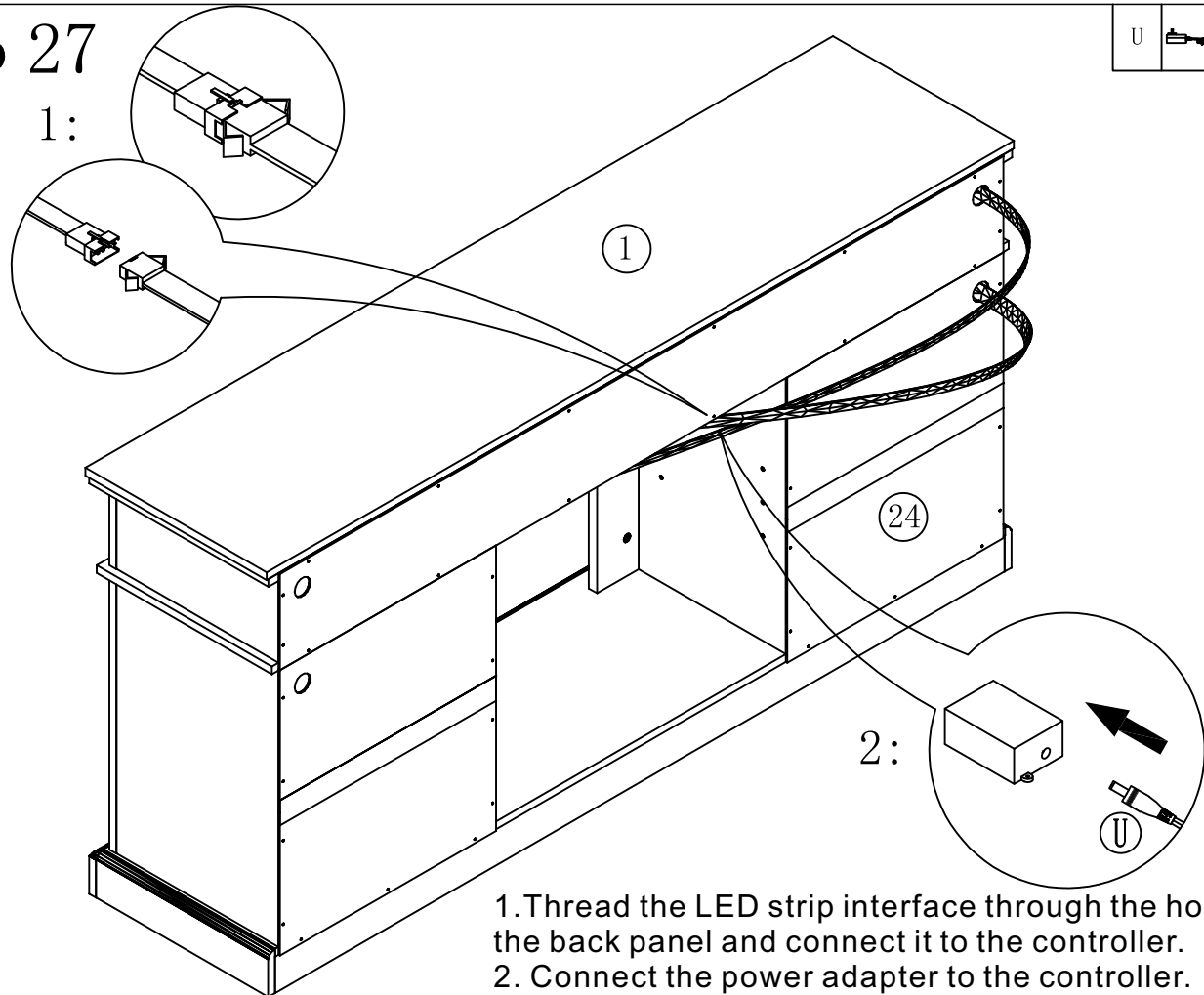
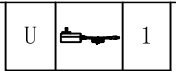

1. Thread the LED strip interface through the hole on the back panel and connect it to the controller.
2. Connect the power adapter to the controller.

## Step 28

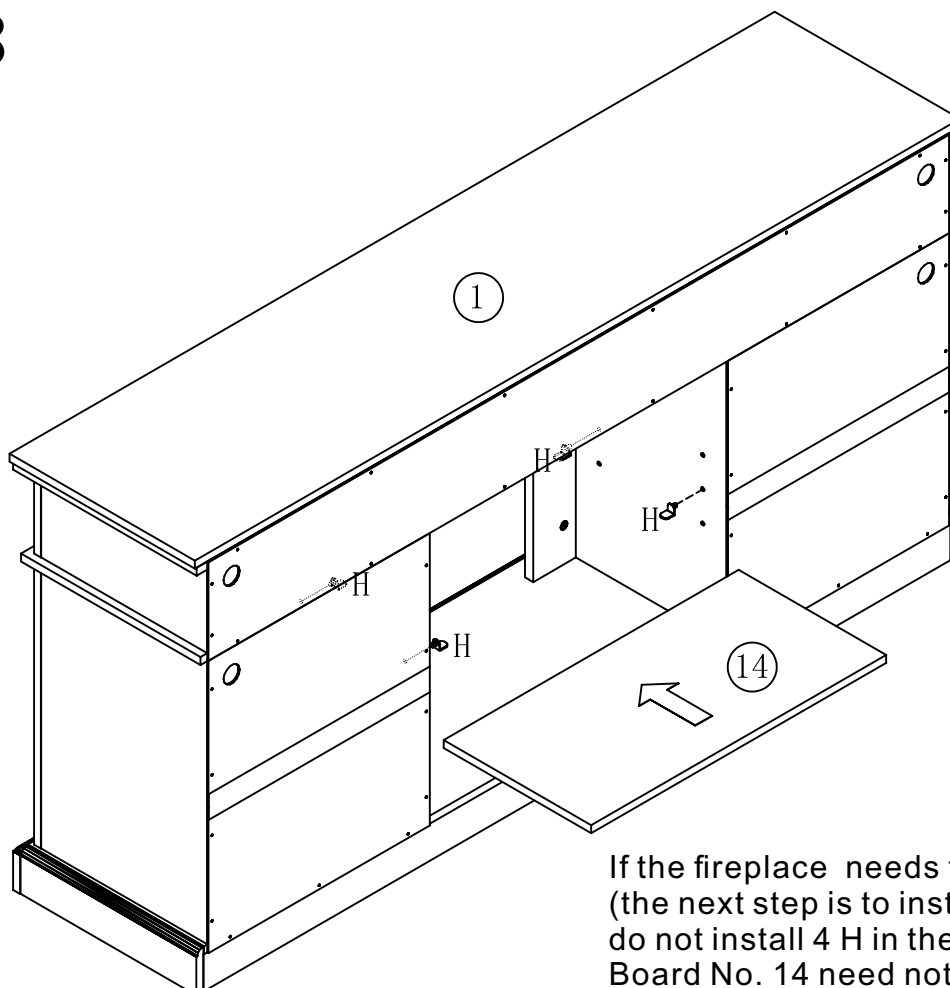

If the fireplace needs to be installed, (the next step is to install the fireplace), do not install 4 H in the middle and Board No. 14 need not be placed.

# Step 29

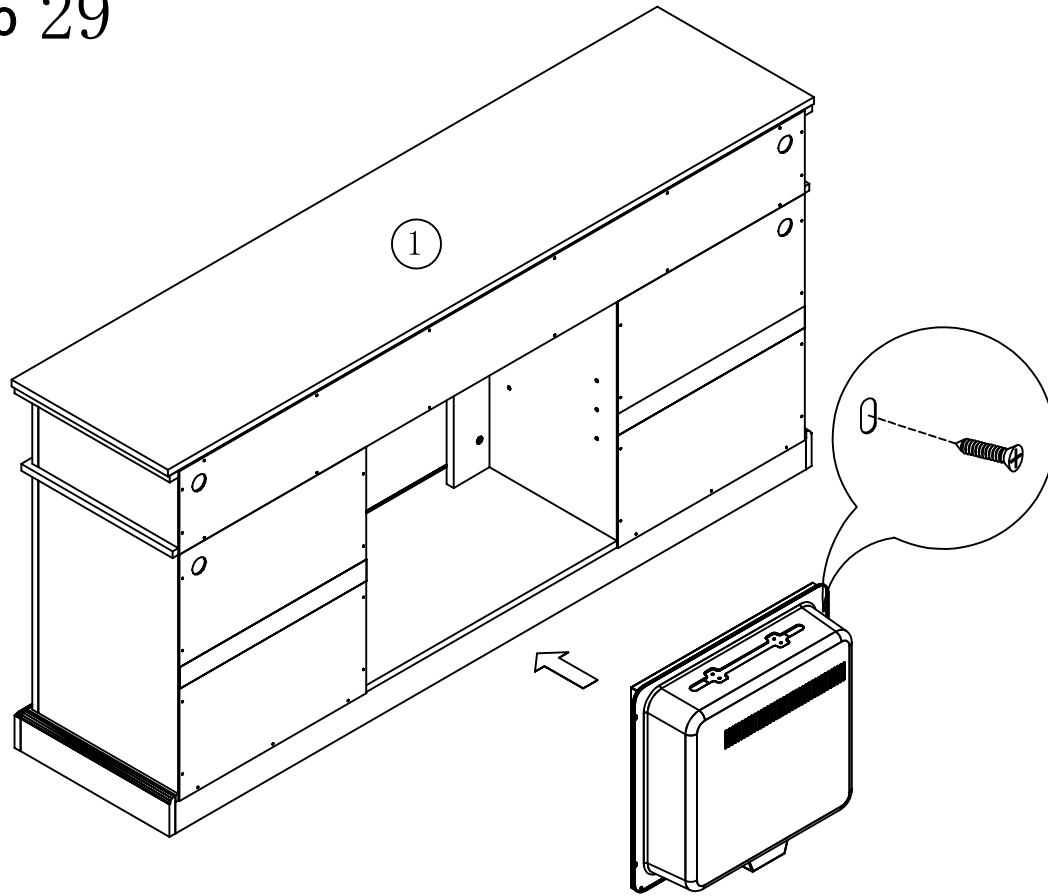

# Step 30

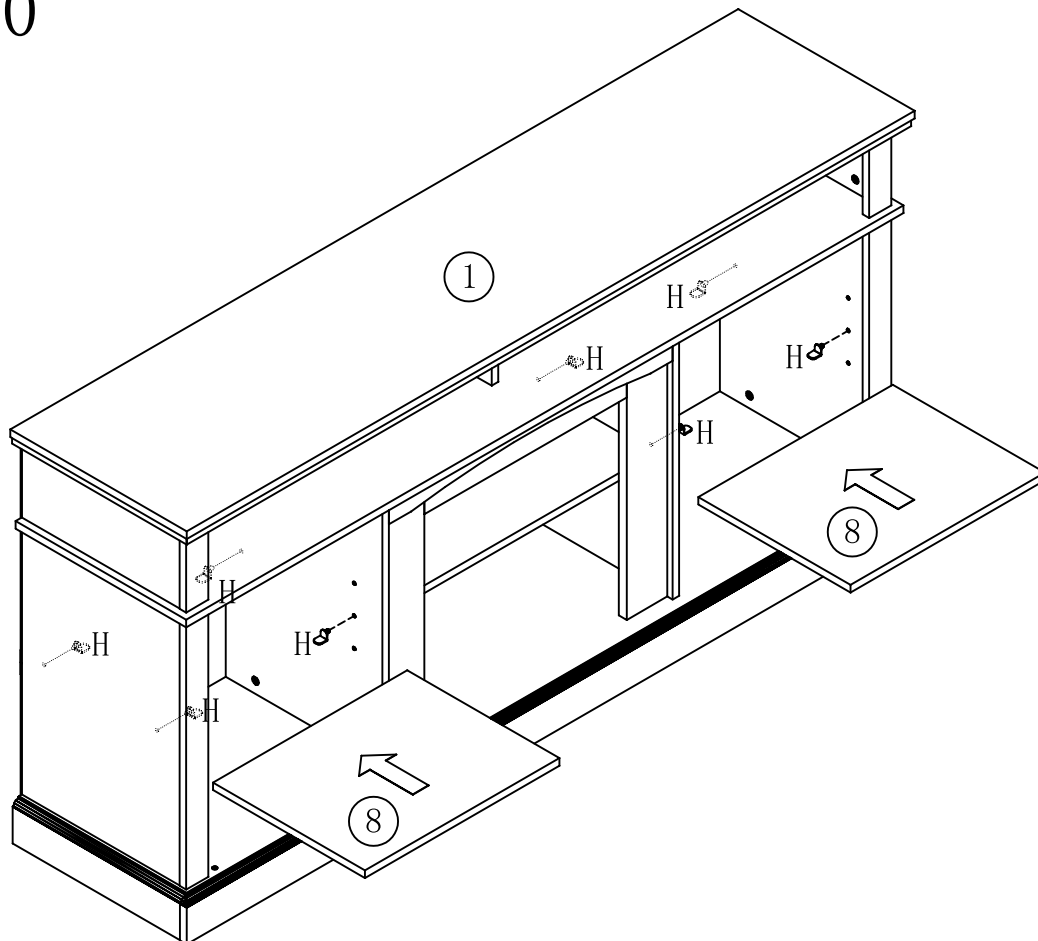

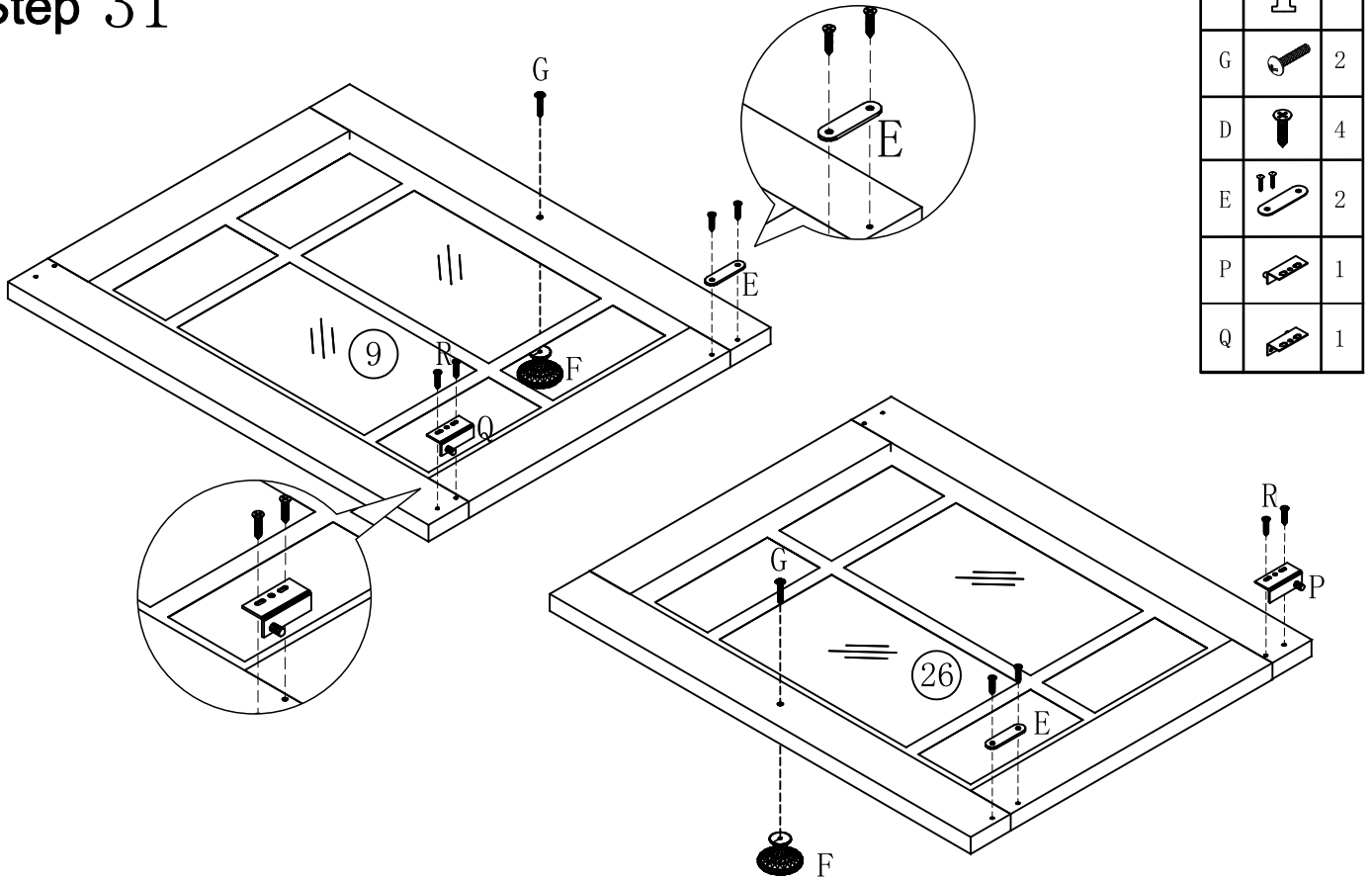

# Step 31

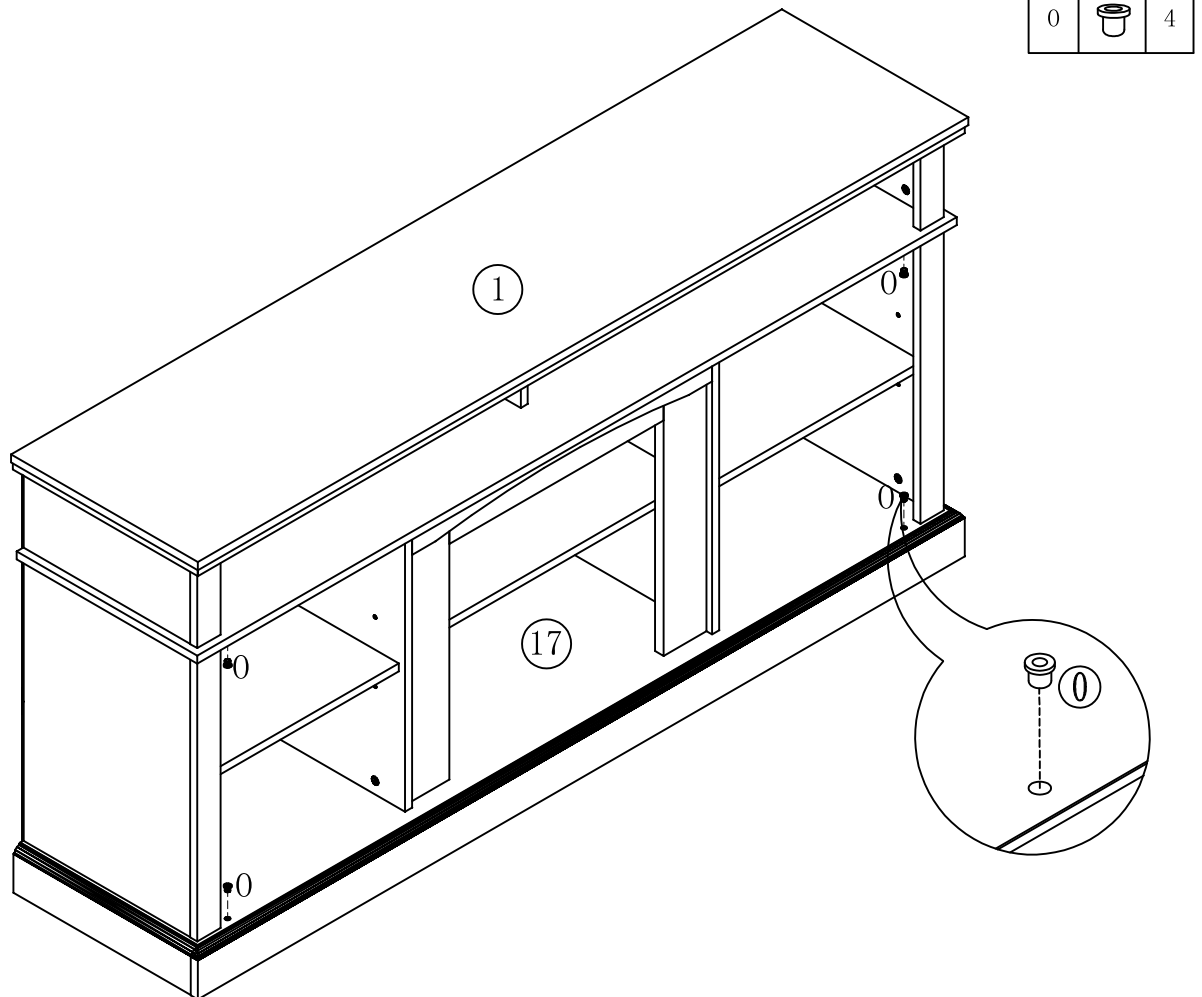

# Step 32



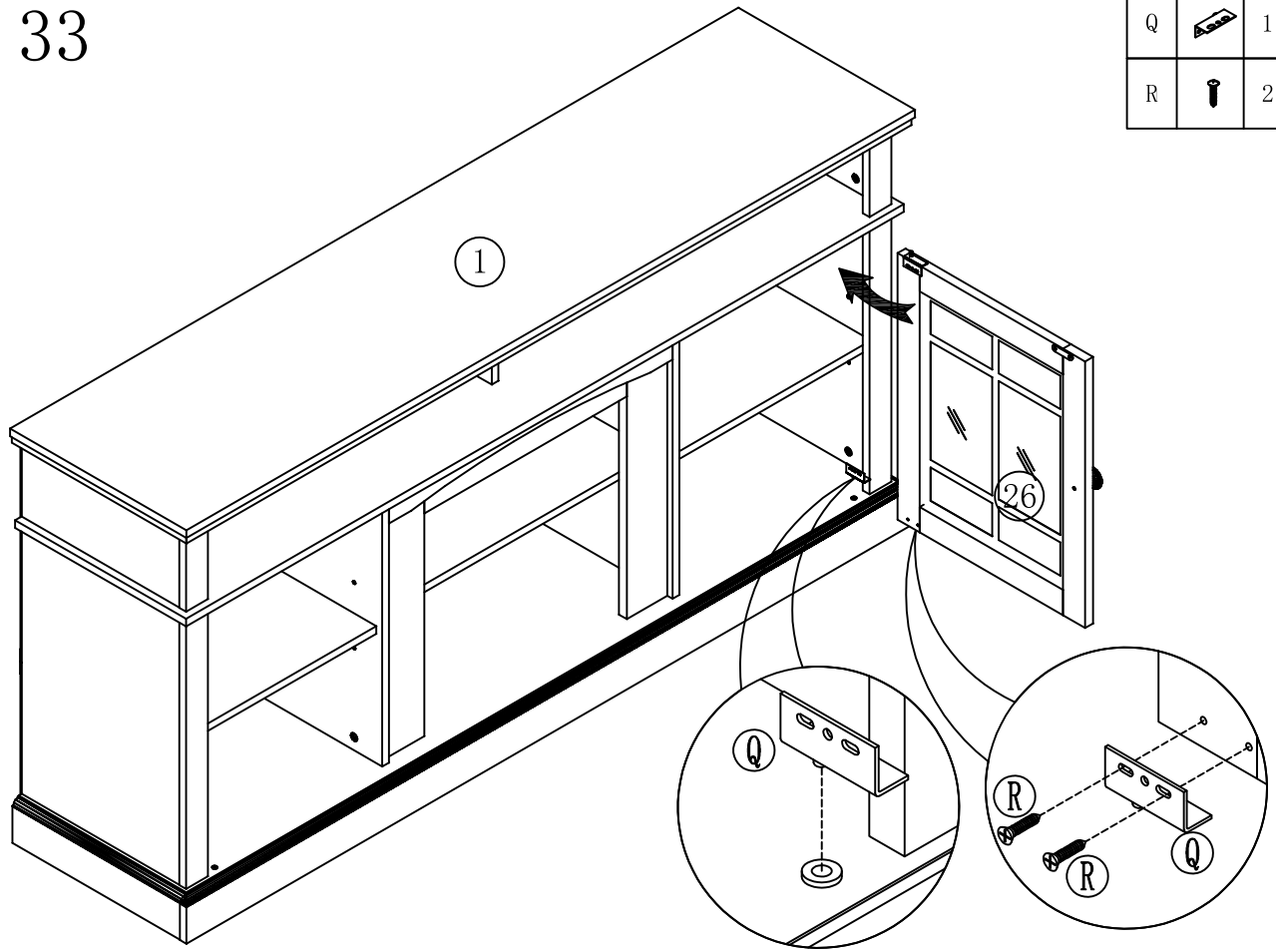

# Step 33

Q		1
R		2



# Step 34

P		1
R		2

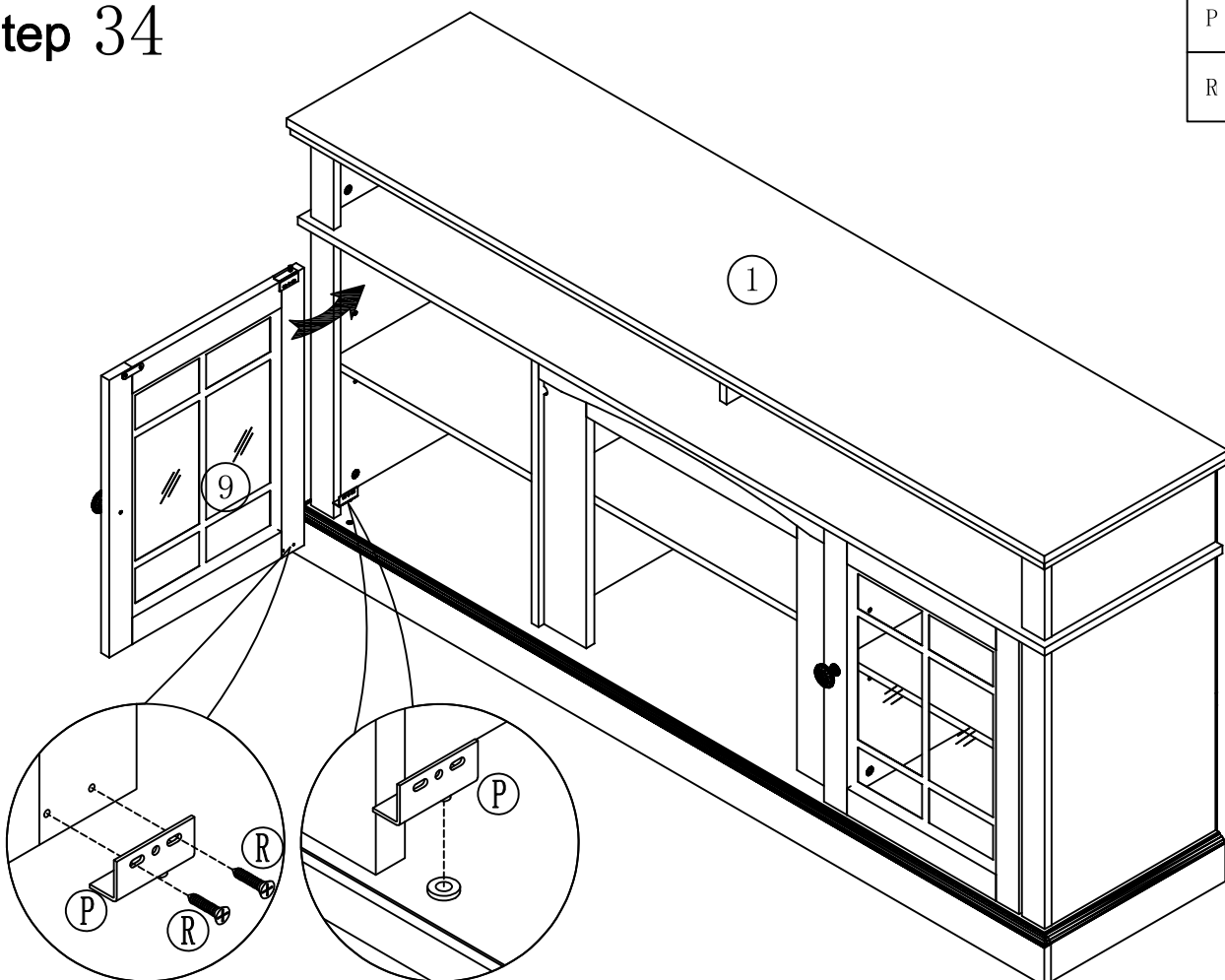

# Step 35

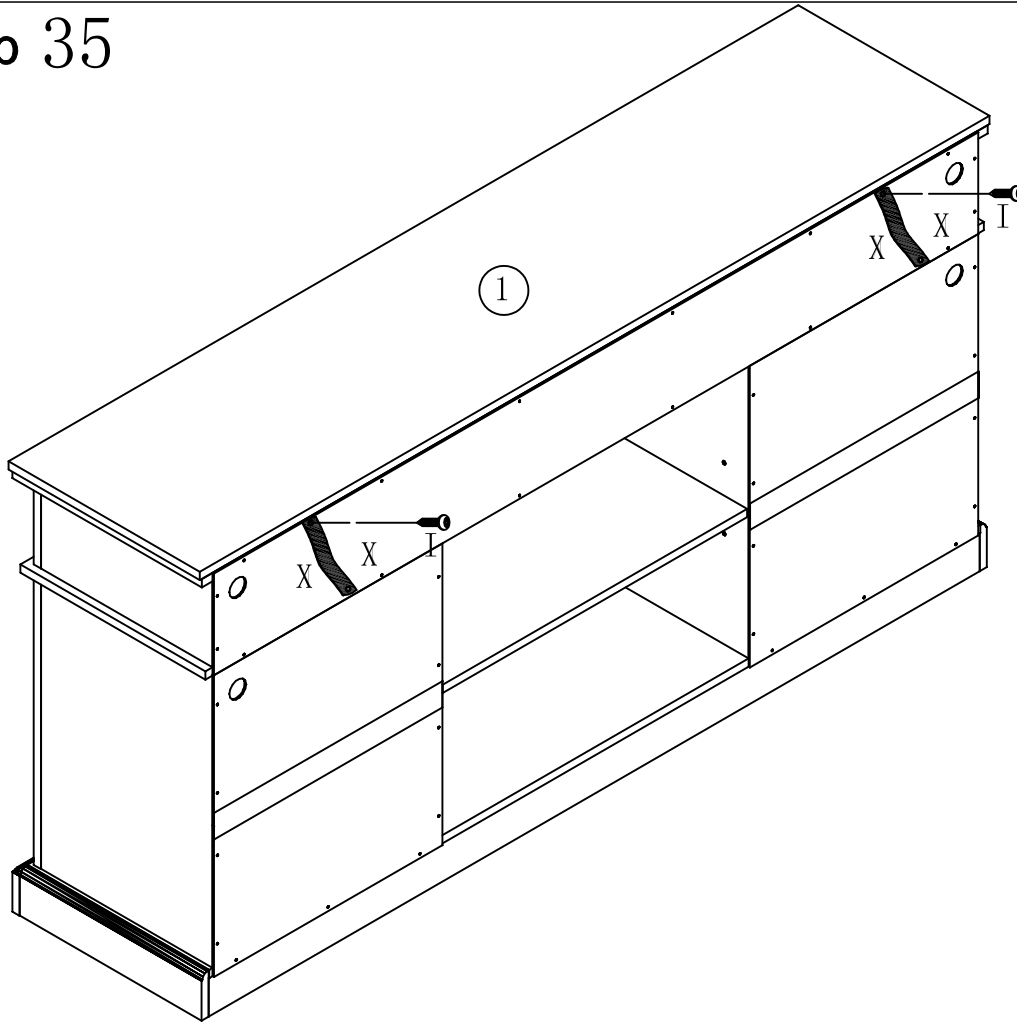

X		2
X		2

# Step 36

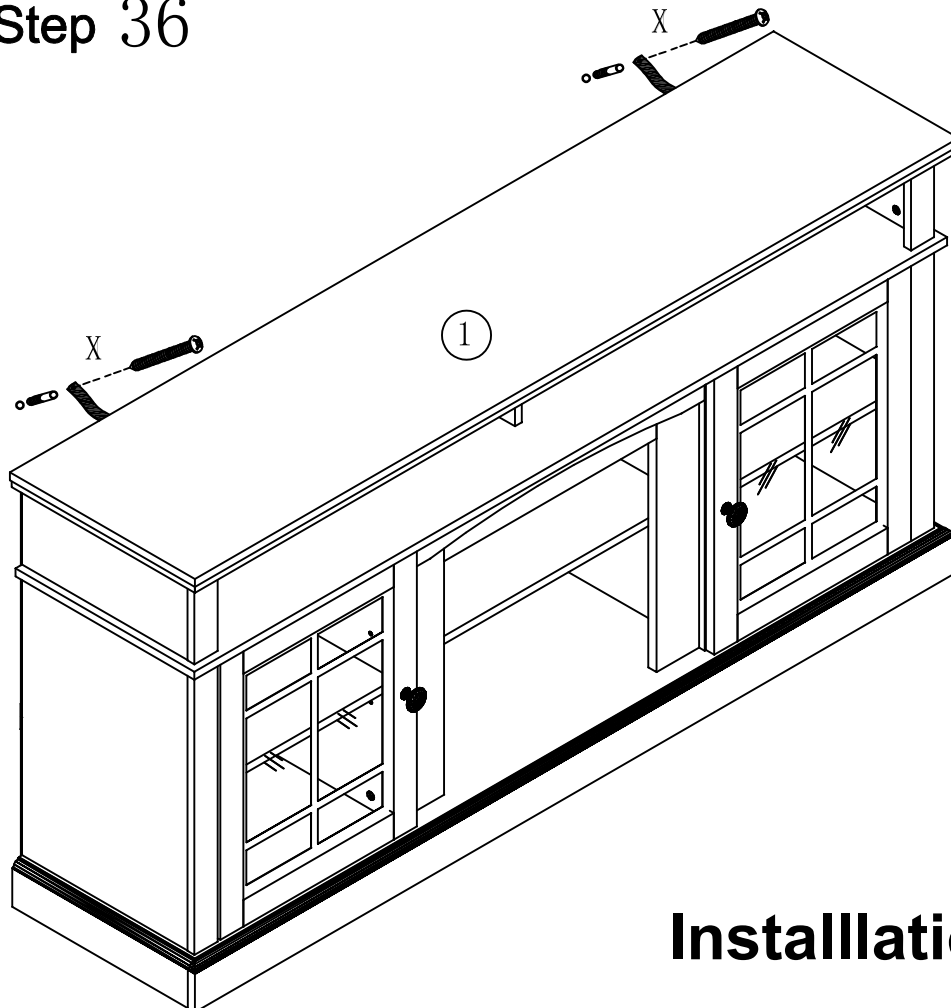

X		2
---	--	---

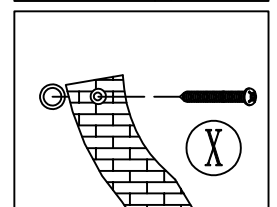
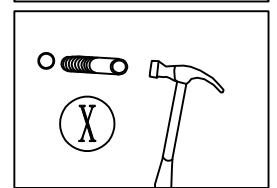
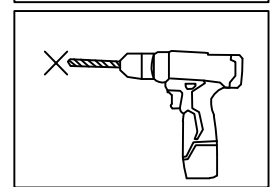
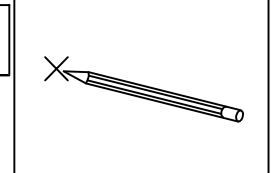

**Installation completed!**