

ASSEMBLY INSTRUCTION

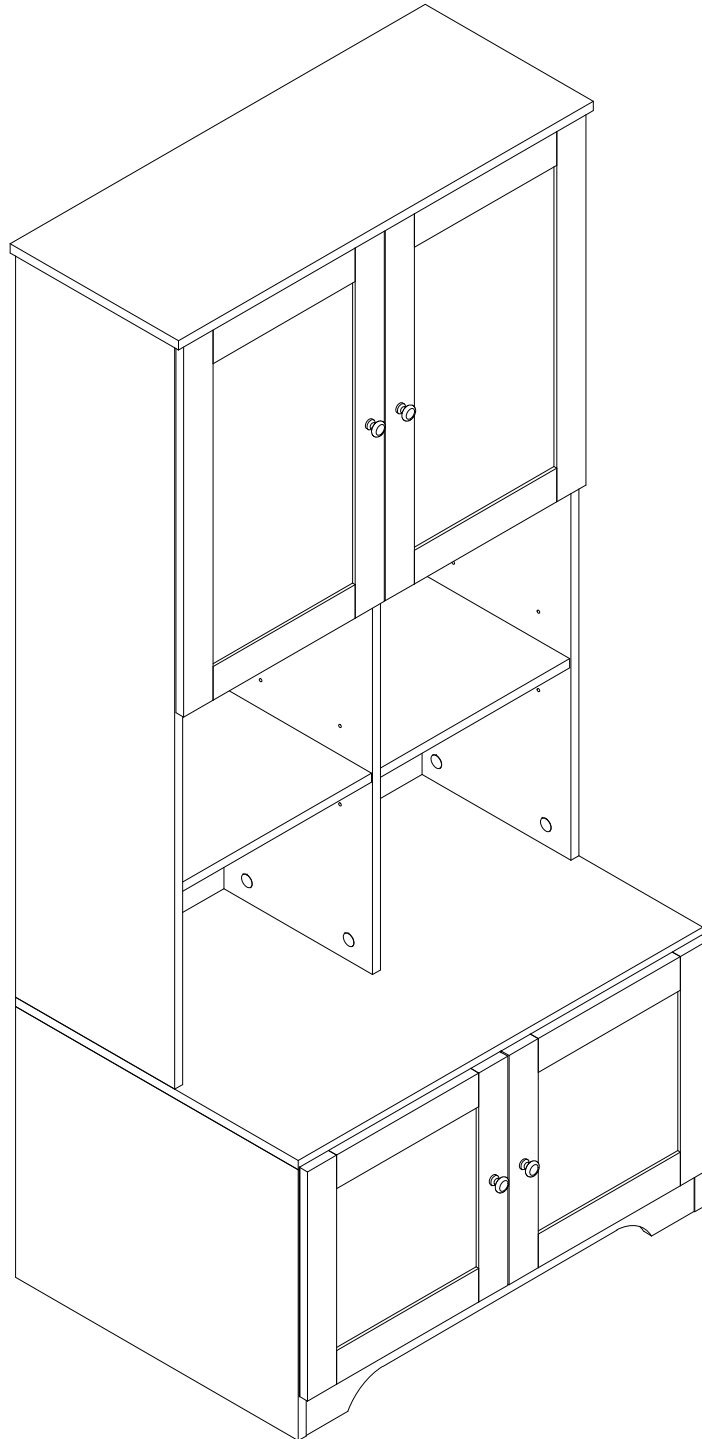

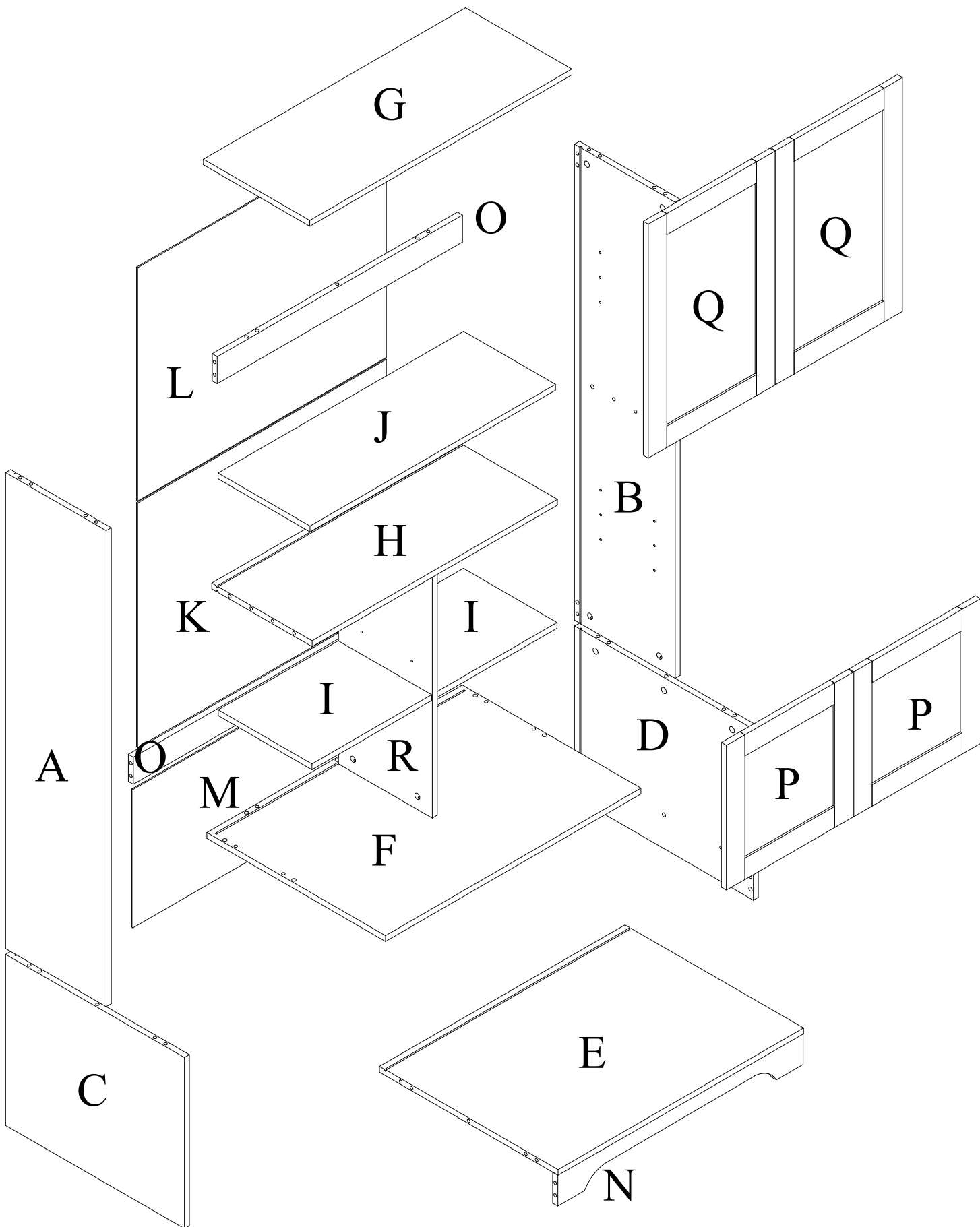

PART LIST

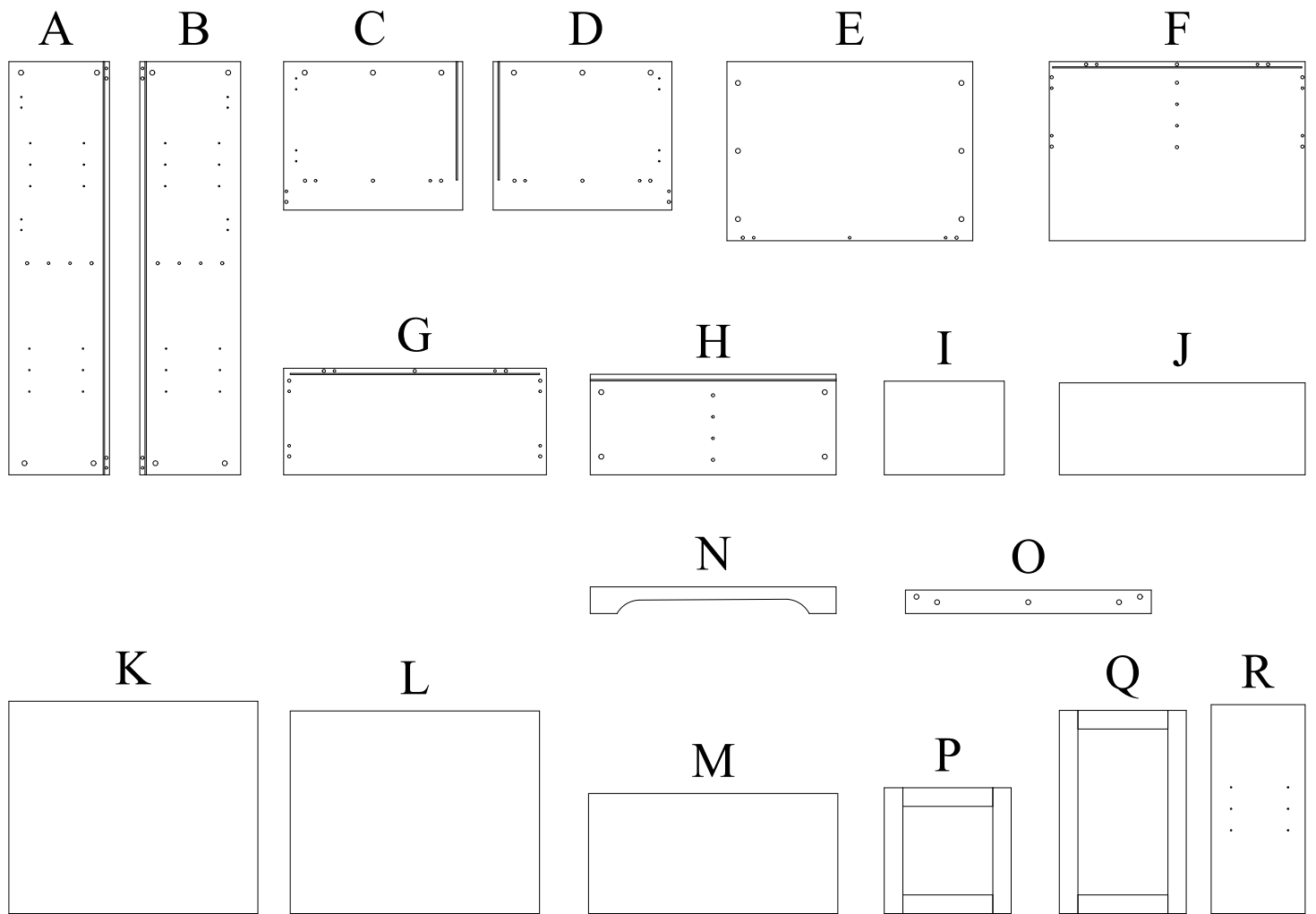

- | | | |
|------------------------------------|---------------------------------------|-------------------------------------|
| A Upper Left Panel (Qty 1) | G Top Panel (Qty 1) | M Lower Back Board (Qty 1) |
| B Upper Right Panel (Qty 1) | H Horizontal Partition (Qty 1) | N Fixed Front Panel (Qty 1) |
| C Lower Left Panel (Qty 1) | I CAM Shelf 1 (Qty 2) | O Fixed Back Panel (Qty 2) |
| D Lower Right Panel (Qty 1) | J CAM Shelf 2 (Qty 1) | P Lower Cabinet Door (Qty 2) |
| E Bottom Board (Qty 1) | K Middle Back Board (Qty 1) | Q Upper Cabinet Door (Qty 2) |
| F Lower Roof Board (Qty 1) | L Upper Back Board (Qty 1) | R Standing Board (Qty 1) |

HARDWARE

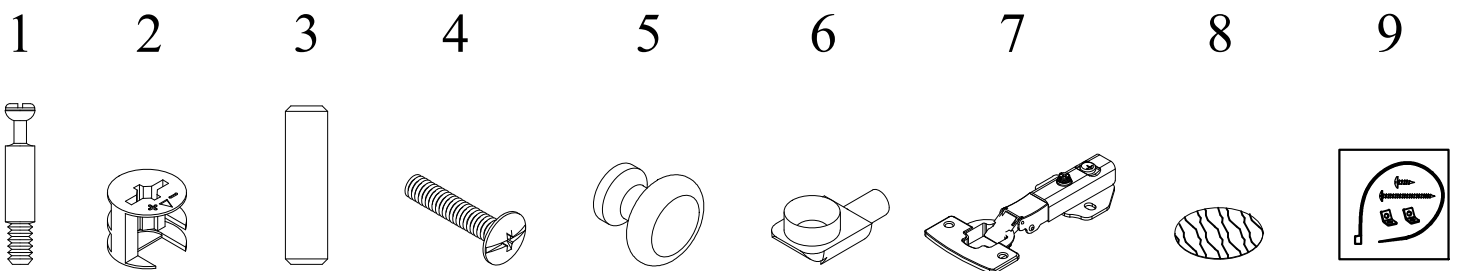

- | | | |
|--------------------------------|----------------------------------|--|
| 1 CAM Bolt (Qty 42) | 5 Handle (Qty 4) | 9 Tipping Restraint Kit (Qty 1) |
| 2 CAM Lock Nut (Qty 42) | 6 Support Shelf (Qty 12) | |
| 3 Dowel - Wood (Qty 37) | 7 Hinge (Qty 8) | |
| 4 Bolts 1" (Qty 4) | 8 Stamp CAM Lock (Qty 18) | |

STEP 1

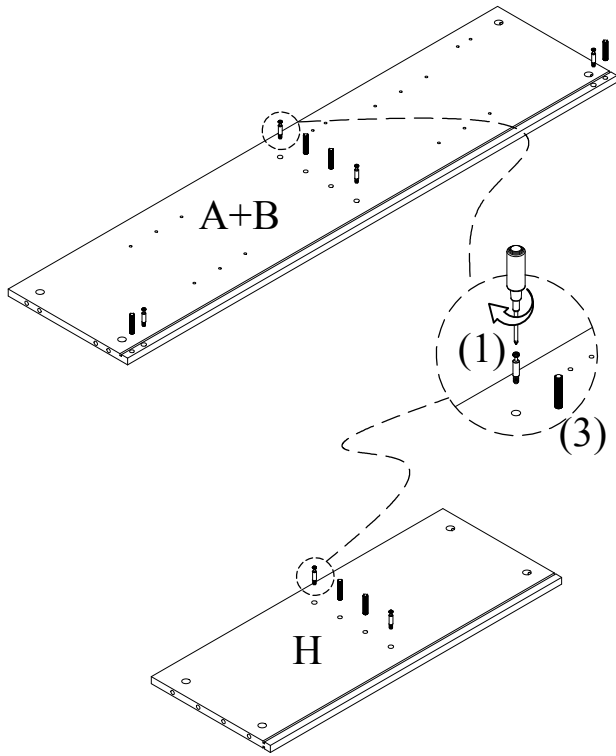
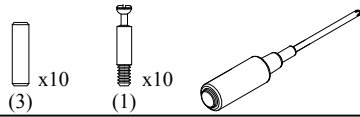

STEP 2

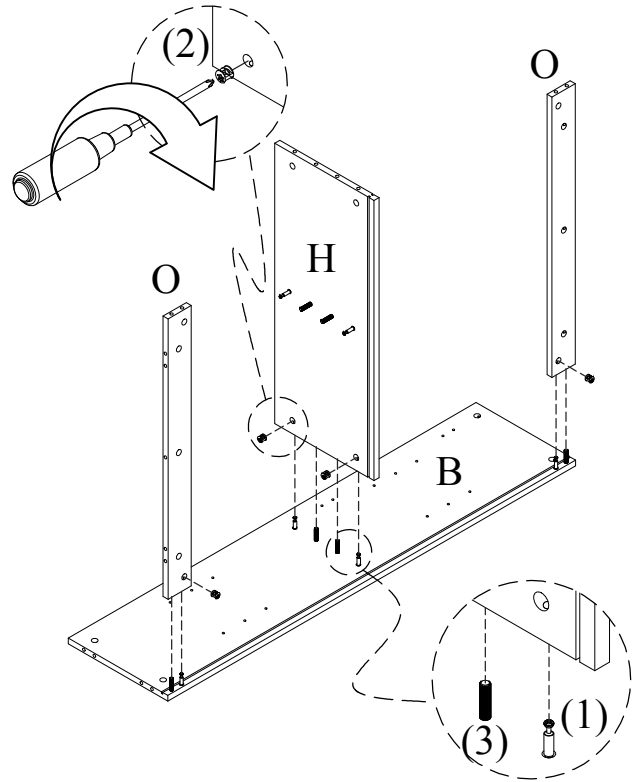
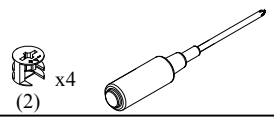

STEP 3

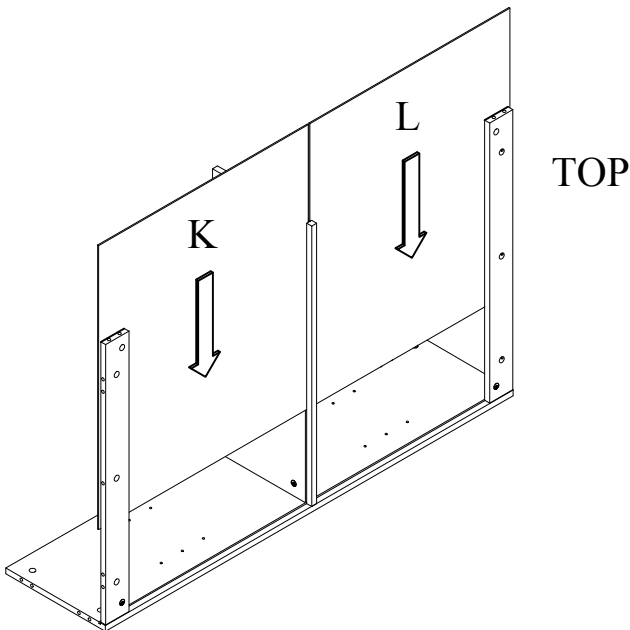

STEP 4

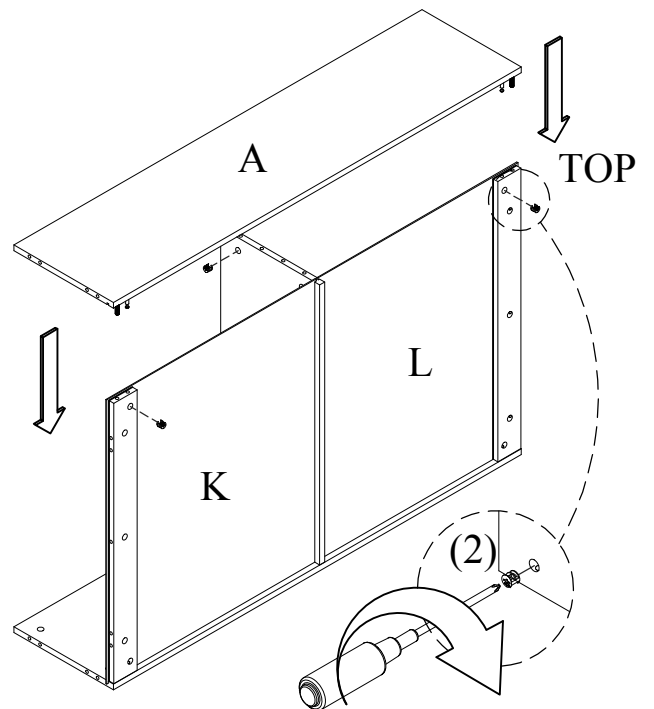
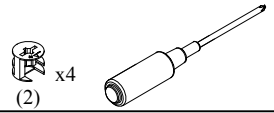

STEP 5

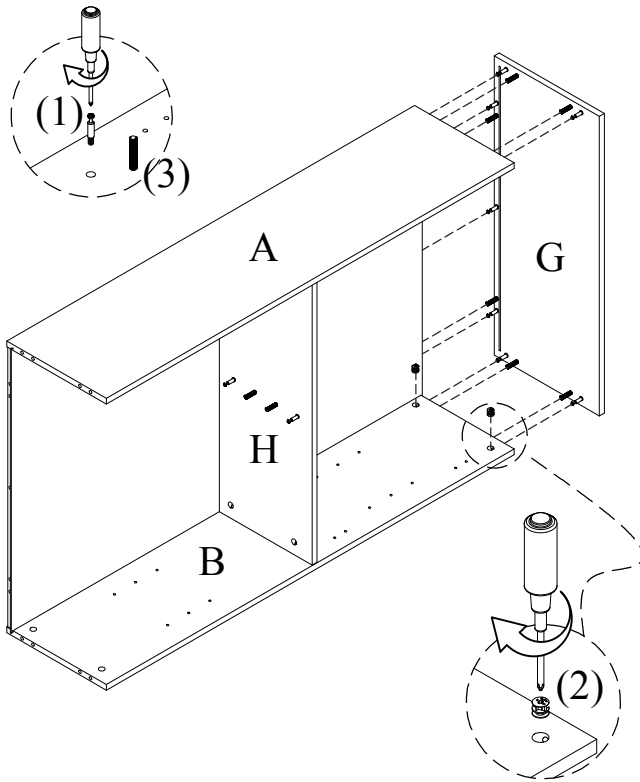
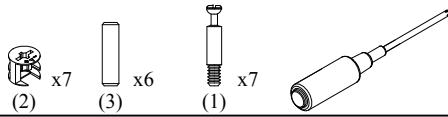

STEP 6

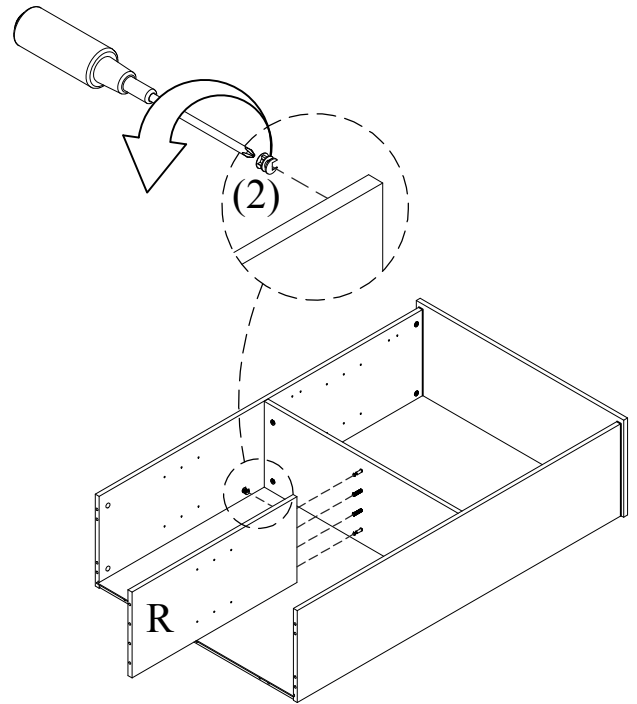
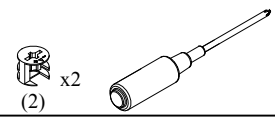

STEP 7

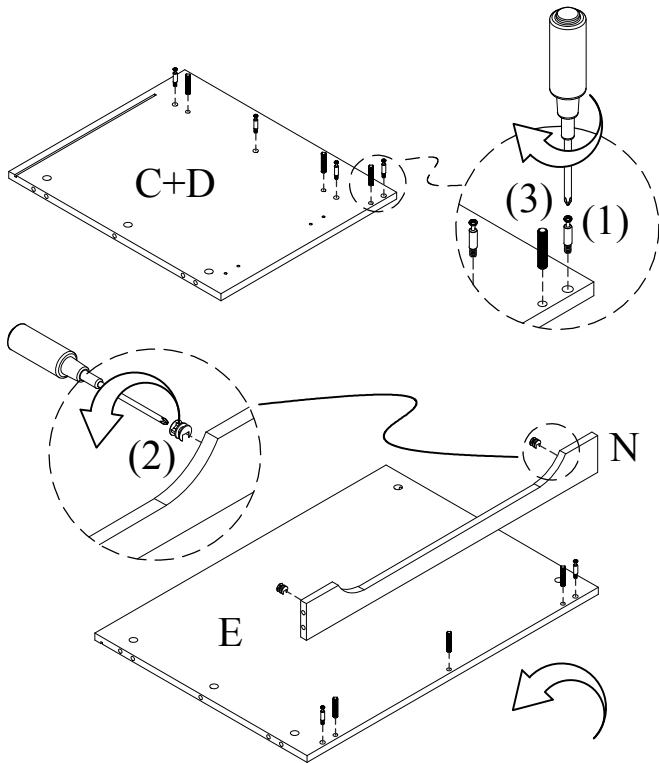
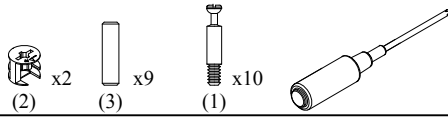

STEP 8

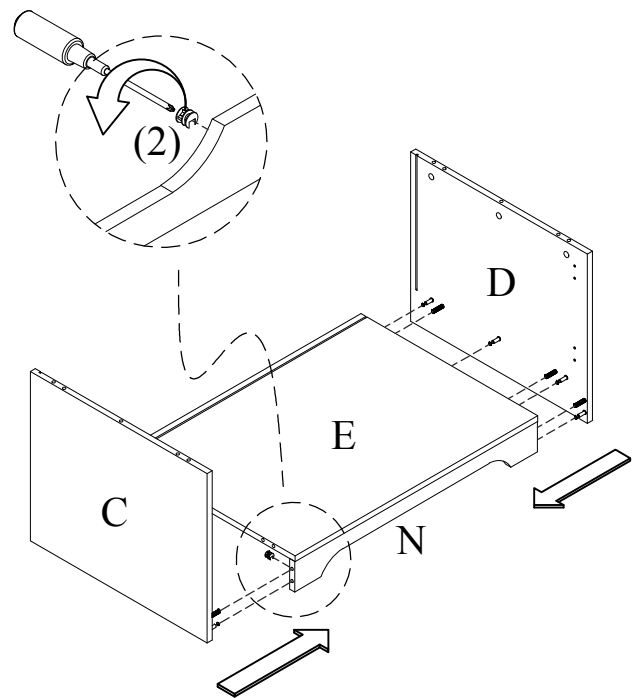
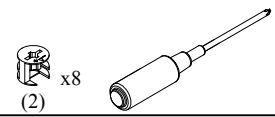

STEP 9

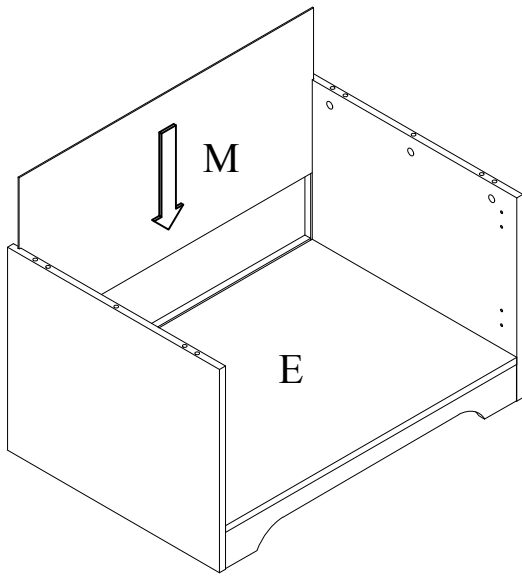

STEP 10

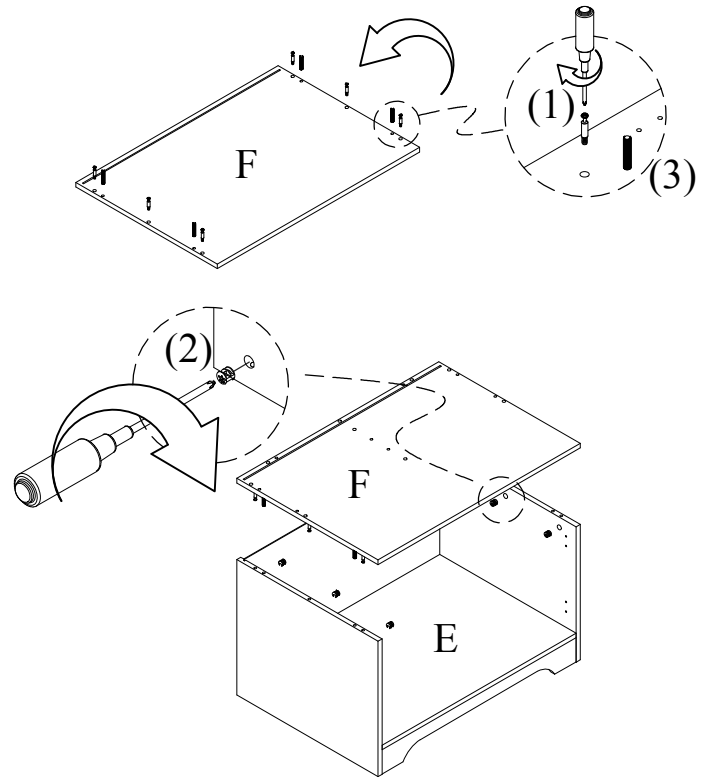
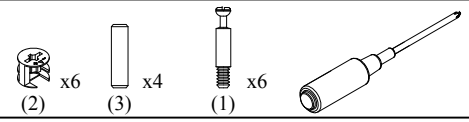

STEP 11

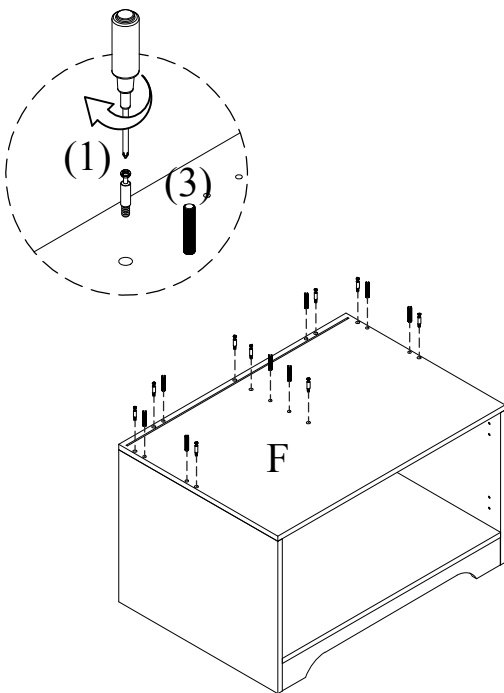
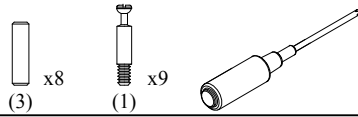

STEP 12

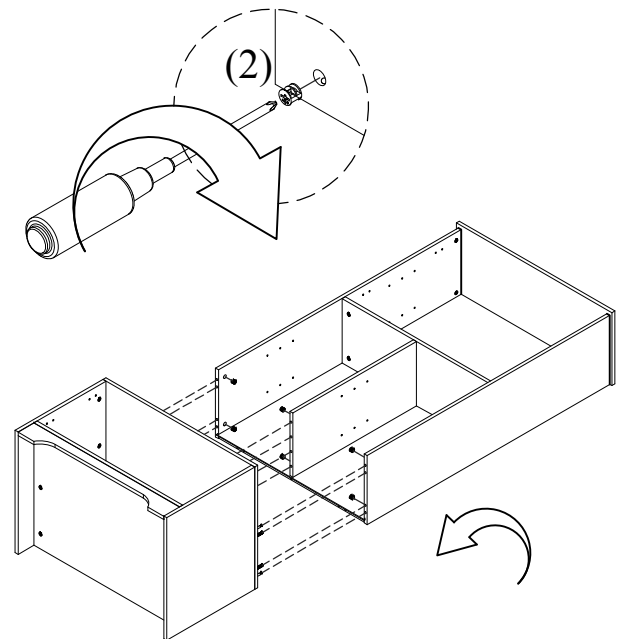
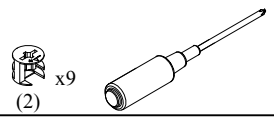

STEP 13

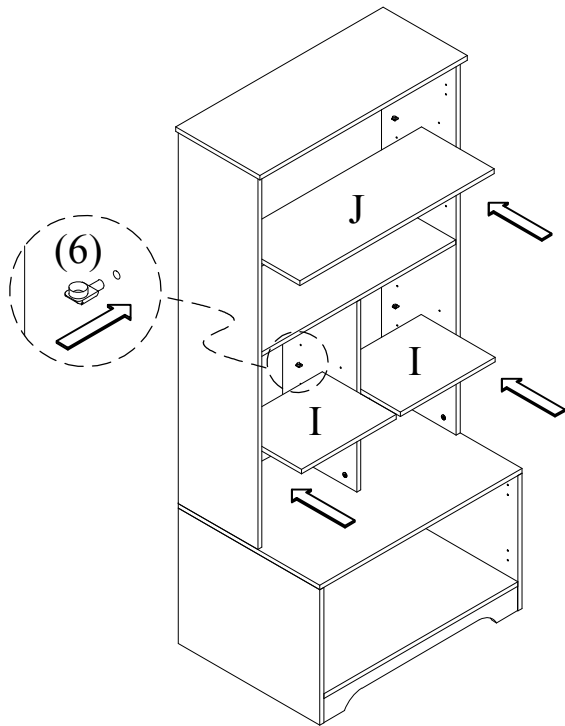
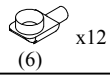

STEP 14

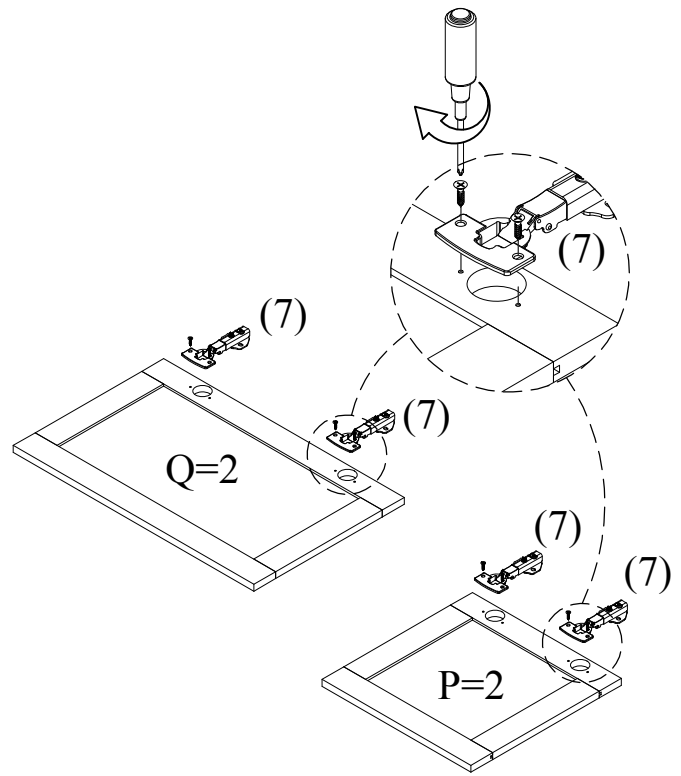
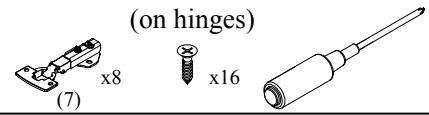

STEP 15

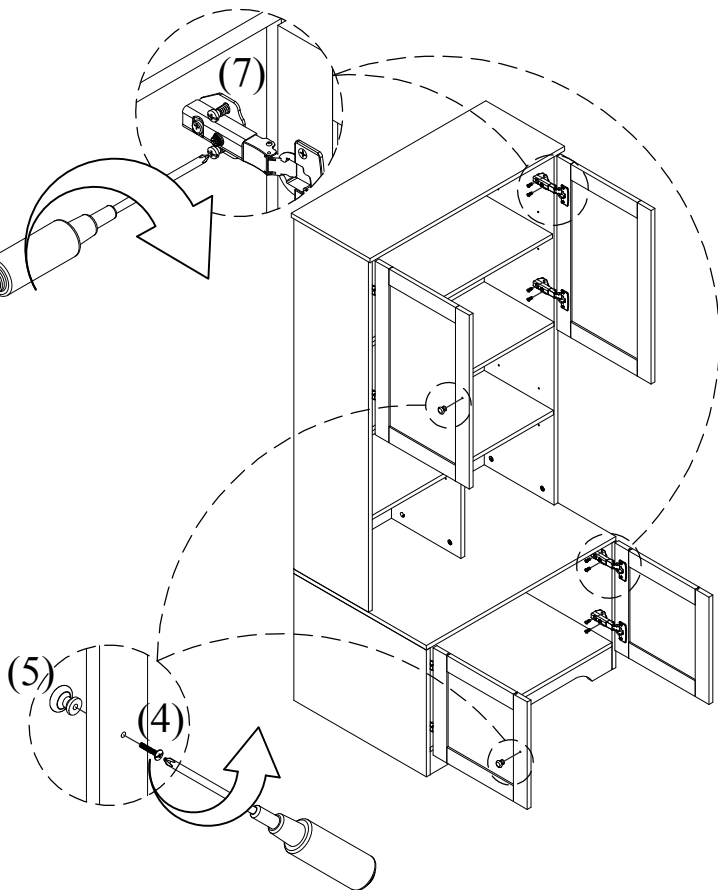
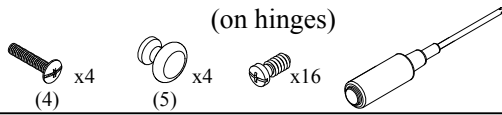

FINISH

