

# ASSEMBLY & INSTRUCTION MANUAL

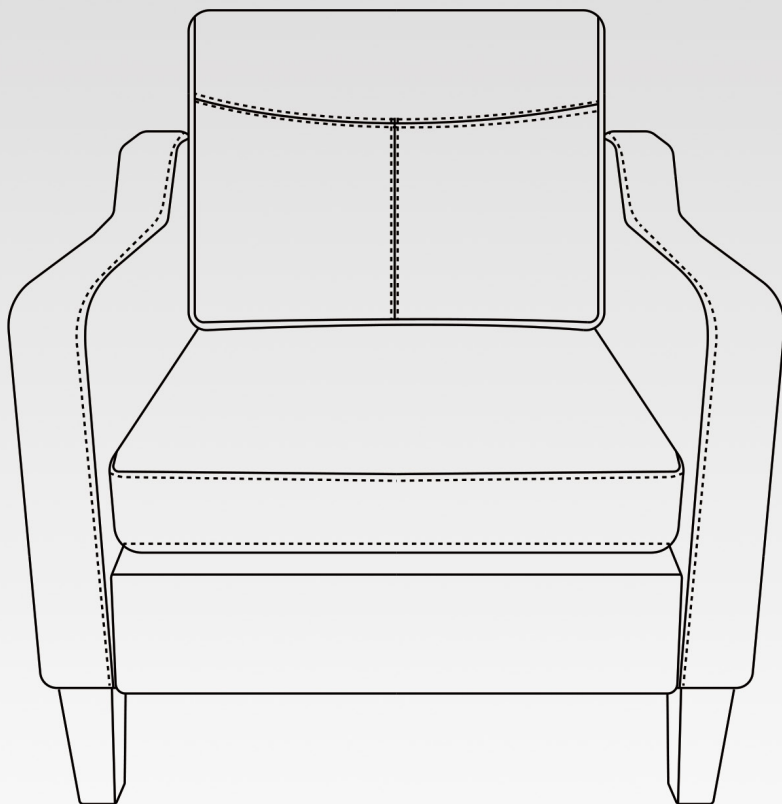

**ACCENT CHAIR**

**WARNING**

Please read the instructions carefully and follow the assembly steps.

To ensure proper assembly, please follow all steps and use all parts provided. Not following this warning may result in serious injury to you or others.

To prevent misalignments, keep the screws loose and do not tighten them until they are all in their correct positions.

Avoid overtightening or forcing the screws, as this could cause them to break, strip, or damage the threads of the holes.

Using the wrong size of screws for a particular part could cause damage to the screw or the part.

Please lubricate all moving parts regularly and tighten all bolts and screws every 6 months, or as needed.

**SAFETY INFORMATION**

**WEIGHT CAPACITY FOR SEATING: 300 LBS (≈136 KG)**



Sit in the center of the chair with your back against the backrest



Do not sit at the front edge of the chair



Do not stand on the chair



Do not use the chair with more than one person



Do not push the chair around when a person is sitting in it



Do not push down on the backrest when a person is reclined



Do not place all your weight on the backrest only

**ASSEMBLY PARTS AND TOOL**

PLEASE MAKE SURE ALL THE PARTS ARE INCLUDED.

A

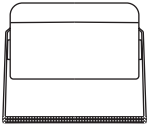

Back Support Brace \*1

B



Bottom Support Bracket \*1

C

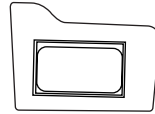

Right Cushion \*1

D

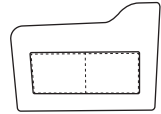

Left Cushion \*1

E

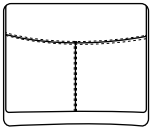

Back Cushion \*1

F

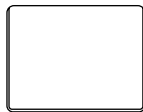

Back Cushion Sponge \*1

G

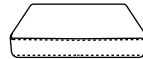

Seat Cushion \*1

H

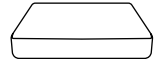

Seat Cushion Sponge \*1

I



Flat Washer \*6

J



M8x35mm Bolts \*6

K



Spacer \*4

L



Leg \*4

M



Foot Pad \*4

N



Wrench \*1



**BEFORE YOU GET STARTED, A FEW POINTERS:**



Having a friend to help makes assembly extra-easy.



Please use the included wrench instead of an ELECTRIC HAND DRILL to avoid damaging the product.

**ASSEMBLY INSTRUCTIONS**

**STEP 1** Insert Back Cushion Sponge (F) into the Back Cushion (E), and you can appropriately adjust the position of the sponge during the process.

Note: When placing the sponge, make sure to get the orientation correct.

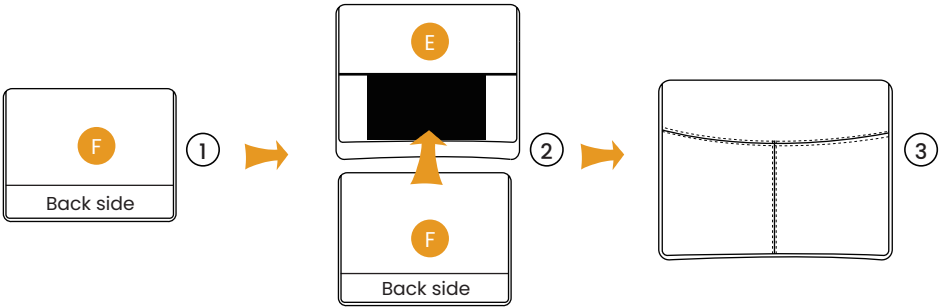

**STEP 2** Insert Seat Cushion Sponge (H) into the Seat Cushion (G), and you can appropriately adjust the position of the sponge during the process.

Note: When placing the sponge, make sure to get the orientation correct.

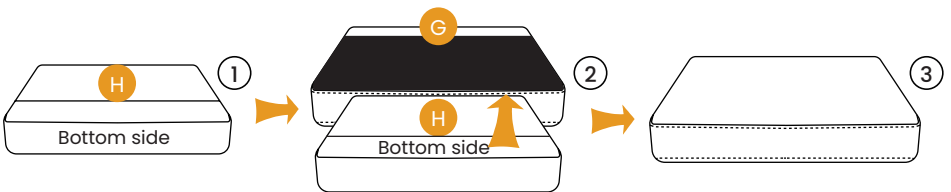

## ASSEMBLY INSTRUCTIONS

- STEP 3** Connect Right Cushion (C) to the Bottom Support Bracket (B), then fix it at the bottom with three Bolts (J) and three Flat Washers (I), using the Wrench (N).

*Note: Simply tighten the bolts to 50% of the specified torque.*

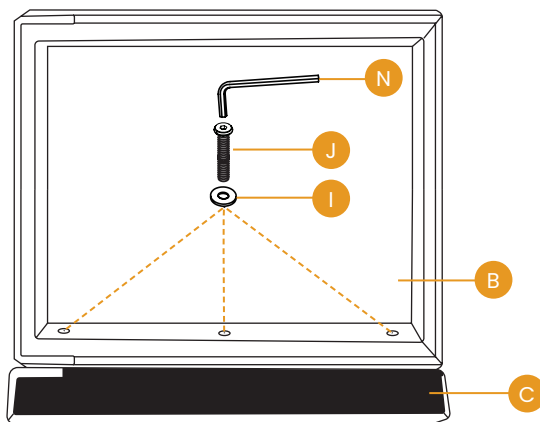

Tighten all the bolts to 50%

- STEP 4** Connect Left Cushion (D) to the Bottom Support Bracket (B) with the installed Right Cushion (C), then fix it at the bottom with three Bolts (J) and three Flat Washers (I), using the Wrench (N).

*Note: Simply tighten the bolts to 50% of the specified torque.*

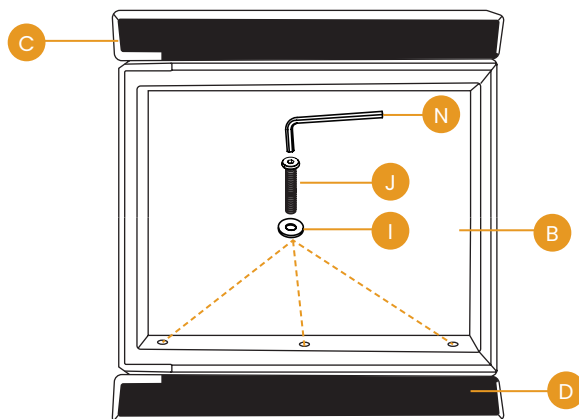

Tighten all the bolts to 50%

## ASSEMBLY INSTRUCTIONS

**STEP 5** Insert Back Support Brace (A) into the Bottom Support Bracket (B), pay attention to aligning it with the slots between the two cushions (C&D).

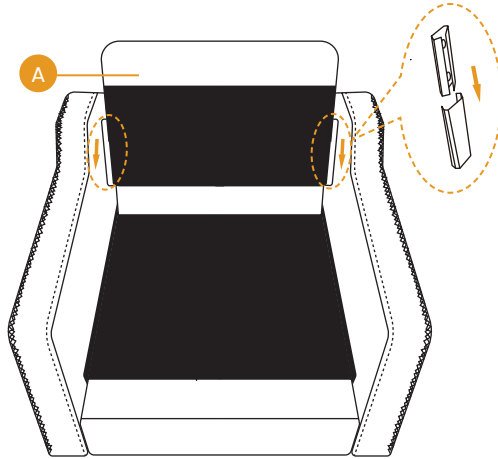

**STEP 6** Tighten all the Bolts (J) at the bottom of the sofa to 100%.



Tighten all the bolts to 100%

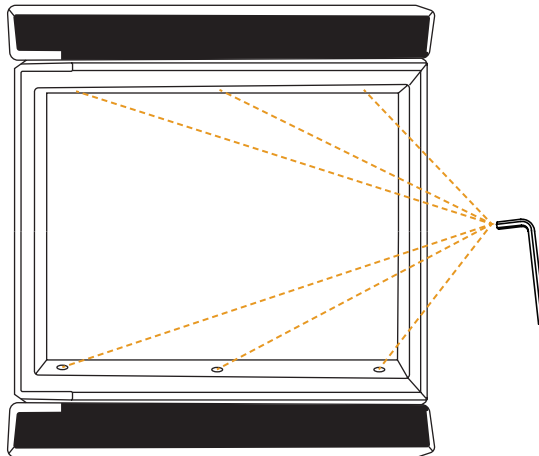

**ASSEMBLY INSTRUCTIONS**

- STEP 7** Put the Spacer (K) on each leg (L), and connect them to the Bottom Support Bracket (B), then remove the sticker from the Foot Pad (M) and stick it onto the Leg (L).

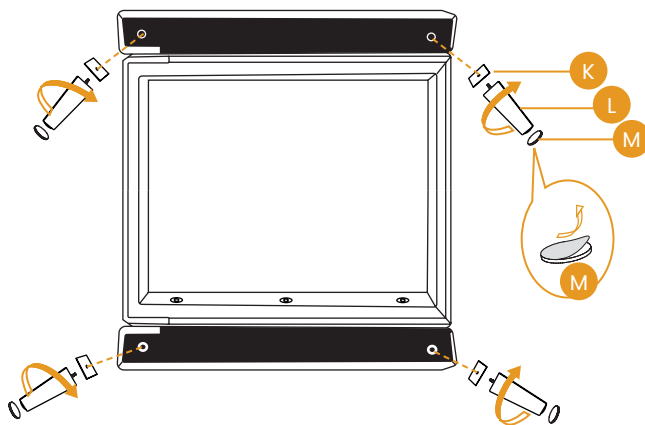

- STEP 8** Pull the back flap down tightly and attach it to the bottom of the seat.

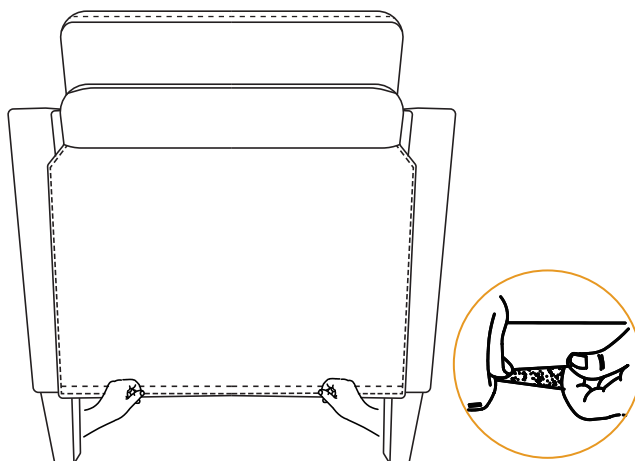

## ASSEMBLY INSTRUCTIONS

- STEP 9** Place the Back Cushion (E) and Seat Cushion (G) in the correct position on the sofa. Now, it is successfully installed.

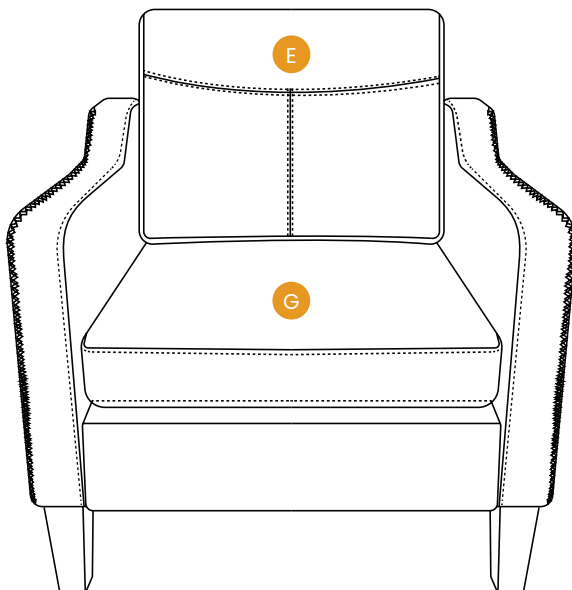

**PRODUCT DETAILS****1. Wing Table-Unfolded:**

Lift it straight up with hand simply.

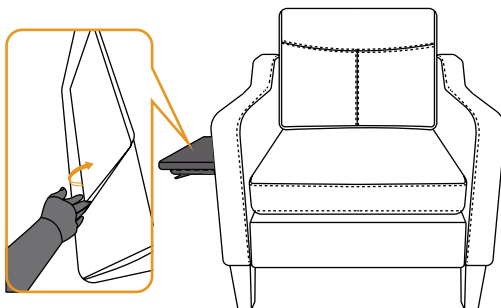
**2. Wing Table-Folded:**

Please press the buttons on both sides at the same time to retract the tabletop.

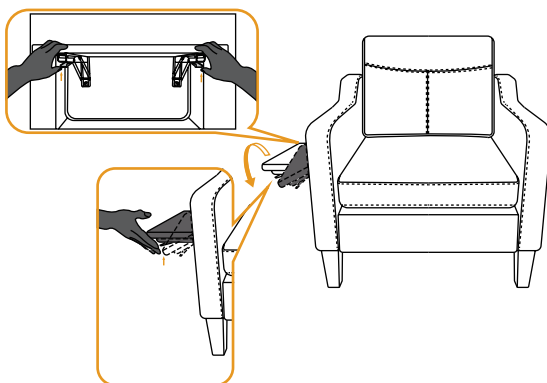

## LIMITED WARRANTY

We promise to repair or replace any chair that is found to be defective in material or workmanship within one year from the date of original purchase, as long as you, the original purchaser, still own it. This is your sole and exclusive remedy under this warranty, subject to the provisions outlined below.

## EXCLUSIONS

This warranty does not apply to, and no other warranty applies to:

- Normal wear and tear, which is to be expected over the course of ownership.
- Misuse, abuse, or excessive use of the product.
- Modifications or attachments to the product that are not approved.
- Products that were not installed, used, or maintained in accordance with the product instructions and warnings.
- Products used for rental purposes or unauthorized retail activities.

Seating Usage: Normal use for seating is defined as equivalent to a single shift, forty-hour (40) workweek. If the seating product is used in a manner exceeding this, the applicable warranty period will be proportionately reduced.

## RETURN POLICY

We offer a 30-day return policy, meaning that all products purchased may be returned to us within that timeframe. You must contact us via email or customer service phone number within 30 days of receiving the product(s), and they must be returned to us without any undue delays.

### CONDITIONS:

- Returned products must be in the same condition as received and returned in their original packaging.
- If the product is not faulty (i.e., if you change your mind or are unhappy with the product for another reason), you are responsible for the cost of return shipping. You must ensure the package arrives safely to us, so we recommend using a courier service that offers tracking.

## LIMITED WARRANTY

- If the product is faulty when received, please contact us, and we will assist you with the return, covering the shipping costs in this case.
- We reserve the right to offer partial refunds for returned products that are not in unused condition, are damaged, or have missing parts not due to our error.

## HOW RETURNS WORK

To request a return, please attach a copy of your invoice as proof of purchase, along with the reason for the return.

We will provide the return address for the product as soon as possible. Once the returned product is received and inspected, we will provide a specific resolution.

If the return is approved, the refund amount will be automatically credited to your original payment method.

## MAINTENANCE INSTRUCTIONS



Dust and clean up spills immediately using a clean, non-colored, lint-free cloth.



Use a mild soap solution and a damp cloth to remove stains.



Do not place hot items directly on the furniture surface without using a protective barrier.



For indoor use only. Do not place the furniture outside.



Do not place furniture in direct sunlight.



Do not write on the furniture surface without a padded barrier to protect it.



Do not clean furniture with harsh cleaners or polishes.



Do not place furniture near heating or cooling vents (keep at least 3 feet away)