

ASSEMBLY INSTRUCTIONS

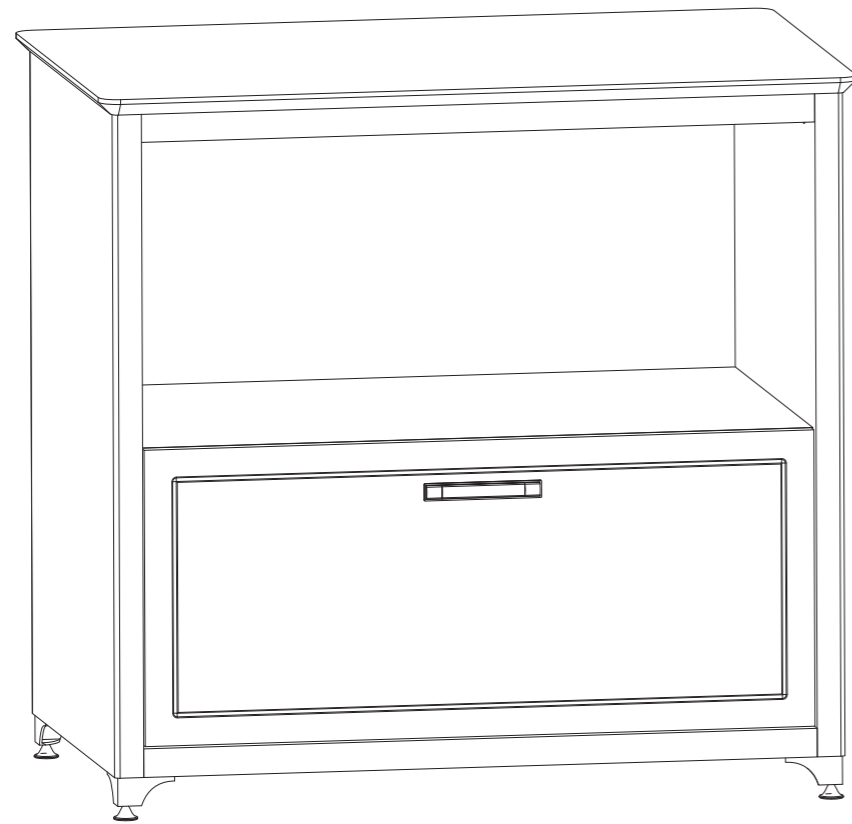

STEP 20

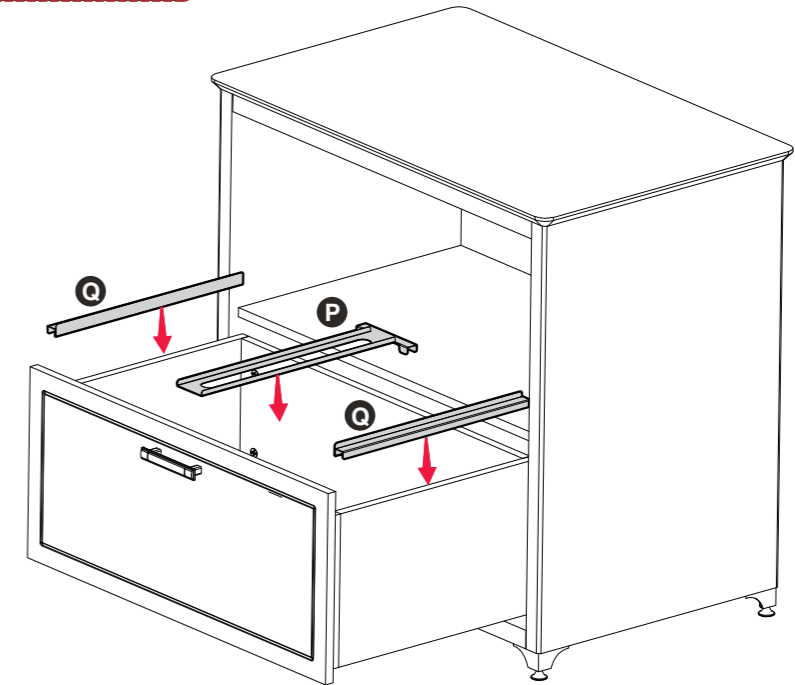
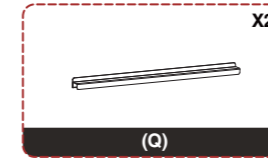
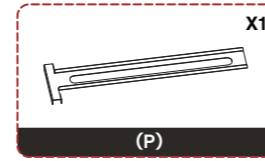

STEP 21

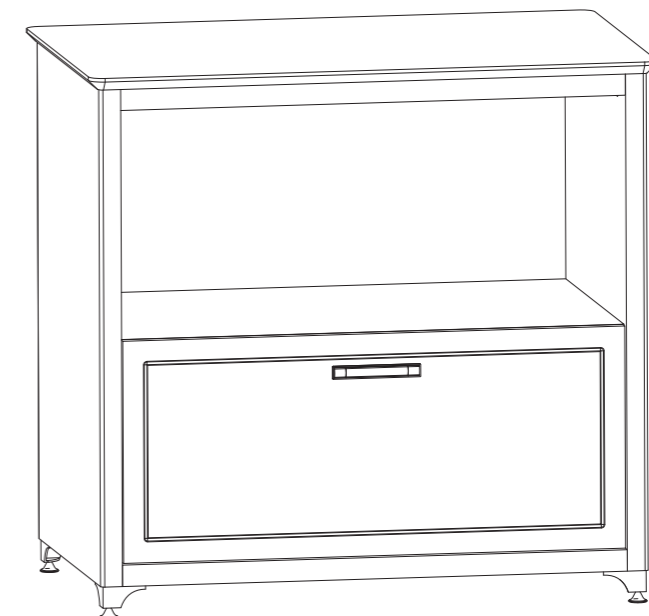

If you need to return the goods, please keep all the packaging materials and return it in the original packaging!
Si vous devez retourner la marchandise, veuillez conserver tous les matériaux d'emballage et le retourner dans l'emballage d'origine!
Si necesita devolver los productos, conserve todos los materiales de embalaje y devuélvalos en el embalaje original!
如需退货请保留好所有包装材料，并按原包装包好退回!

STEP 18

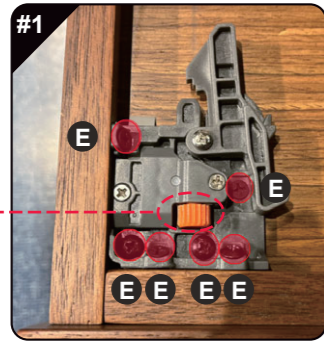
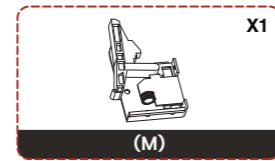
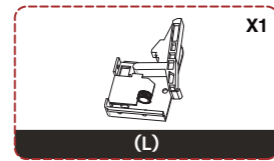
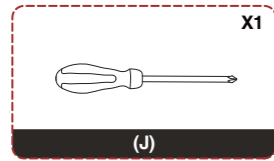
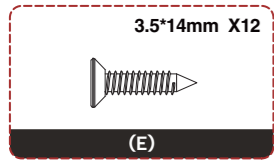

#1
Scroll left and right to adjust drawer height.
Faire défiler vers la gauche et la droite pour régler la hauteur du tiroir.
Desplácese a izquierda y derecha para ajustar la altura del cajón.
左右滚动可调节抽屉高度。

STEP 19

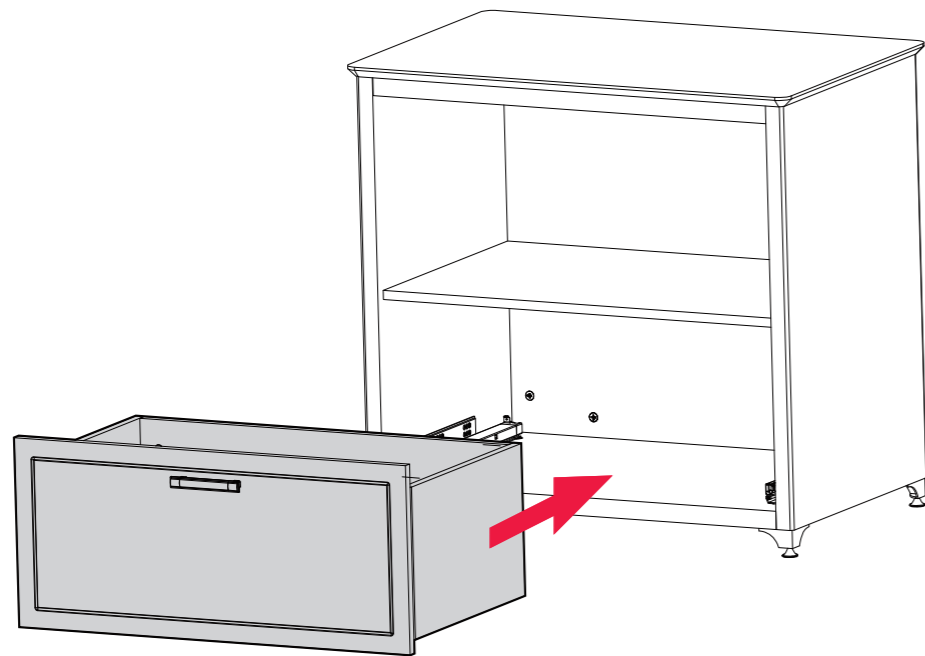

PARTS / PIÈCES / PARTES / 部件清单

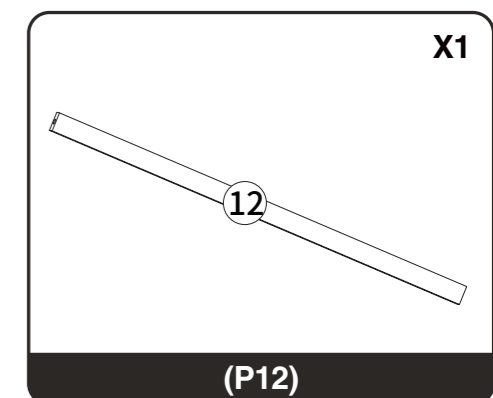
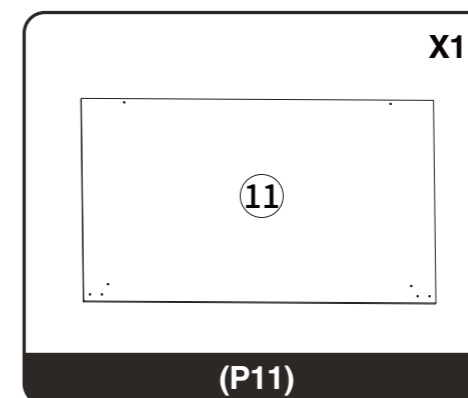
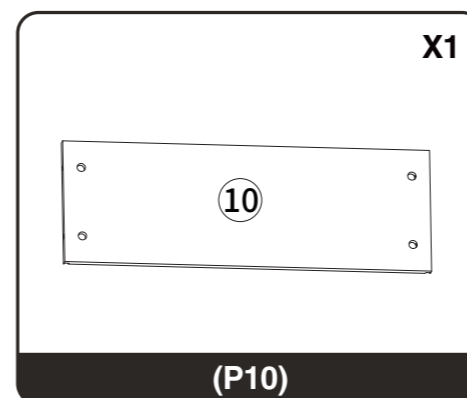
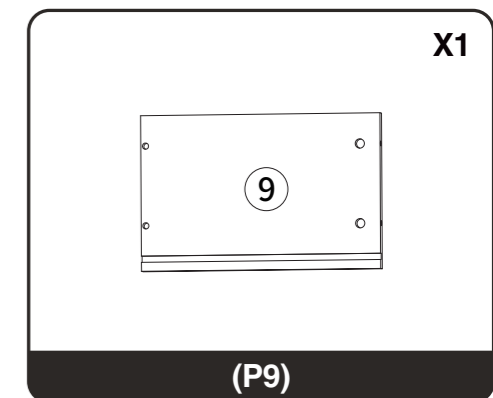
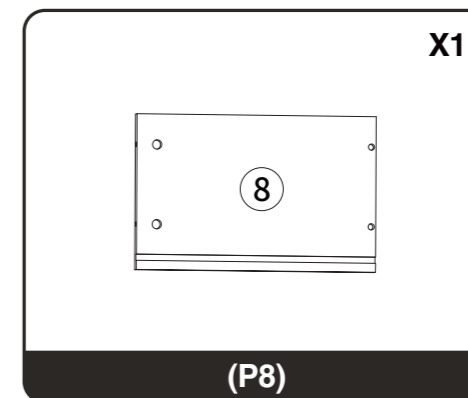
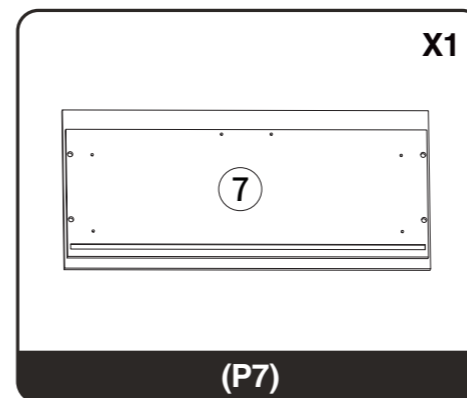
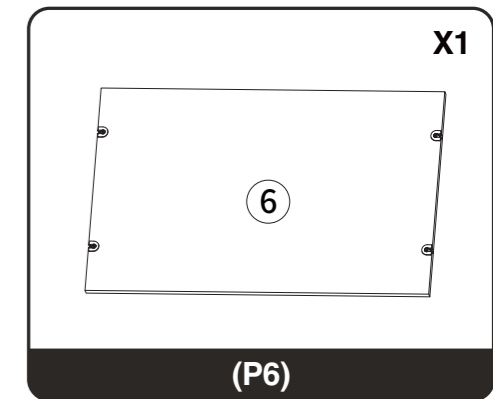
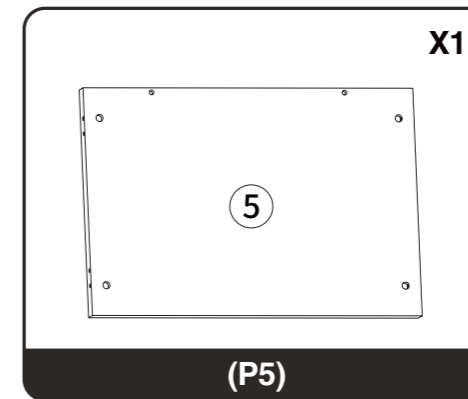
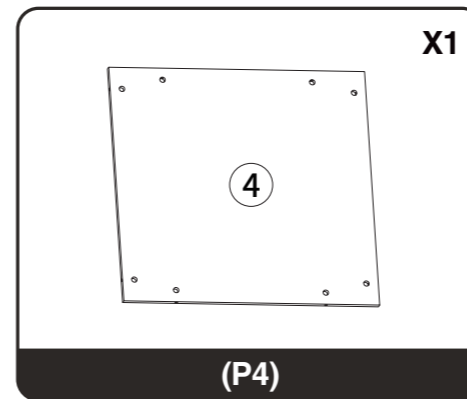
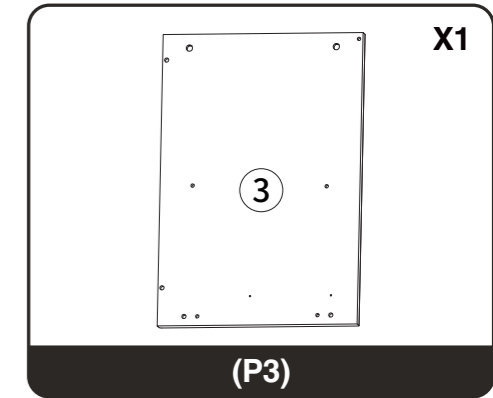
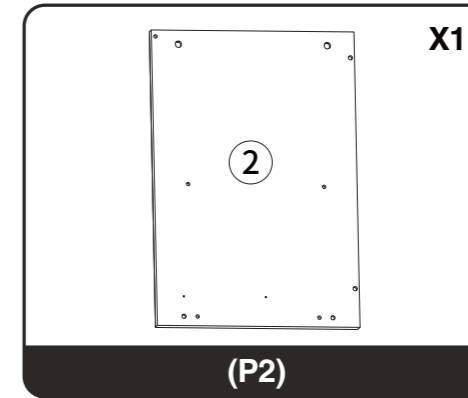
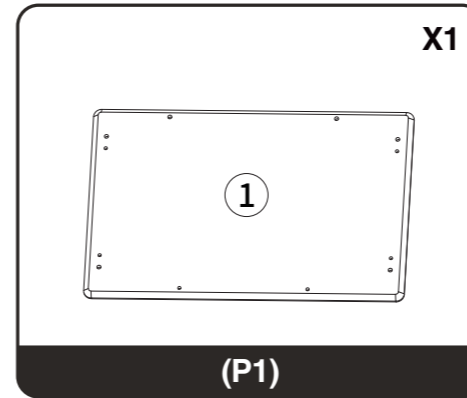

HARDWARE / MATÉRIEL / HARDWARE / 配件清单

X24	X24	X2	X12
X16	X2	X12	X4
X4	X1	X1	X1
X1	X1	X1	X1
X2	X5 Wood Grain Sticker Autocollant en grain de bois Pegatina de grano de madera 木纹贴纸		

STEP 16

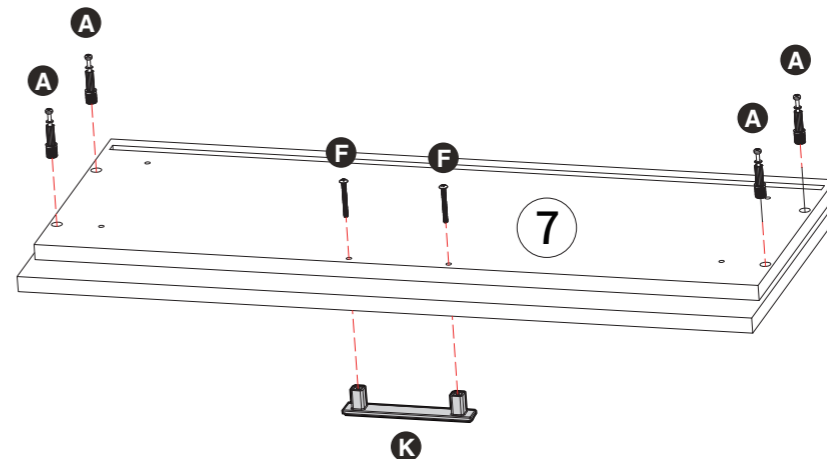
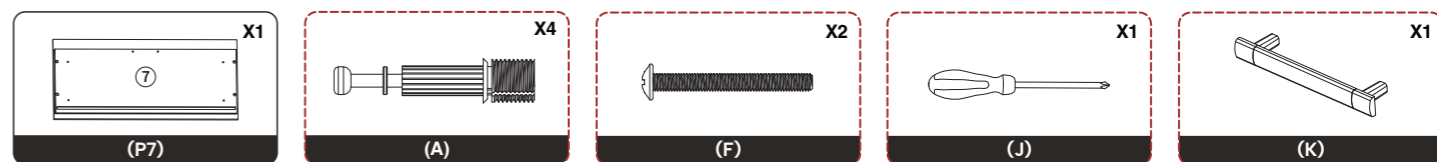

STEP 17

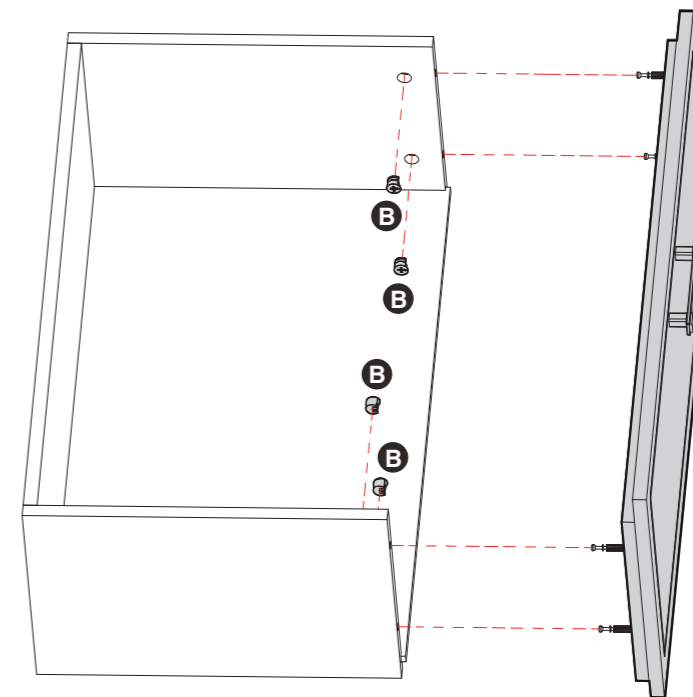
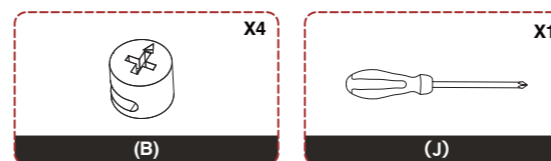

STEP 14

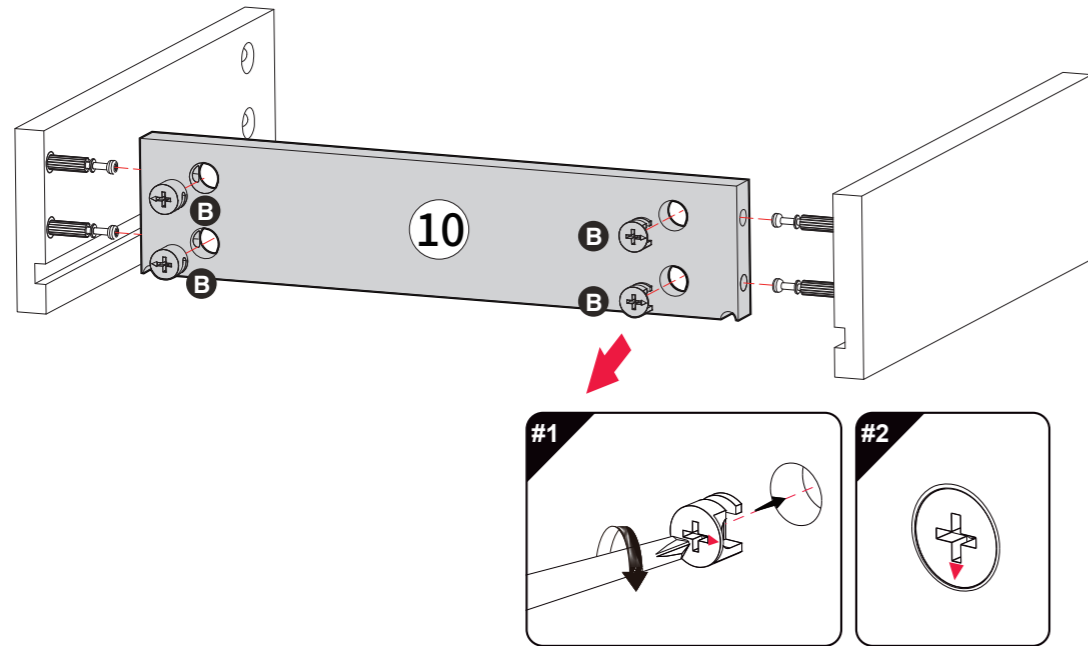
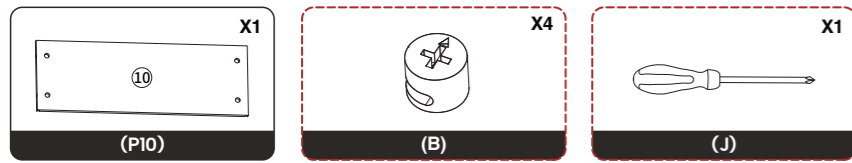

Note the direction of the arrow
 Notez le sens de la flèche
 Tenga en cuenta la dirección de la flecha
 注意箭头方向。

STEP 15

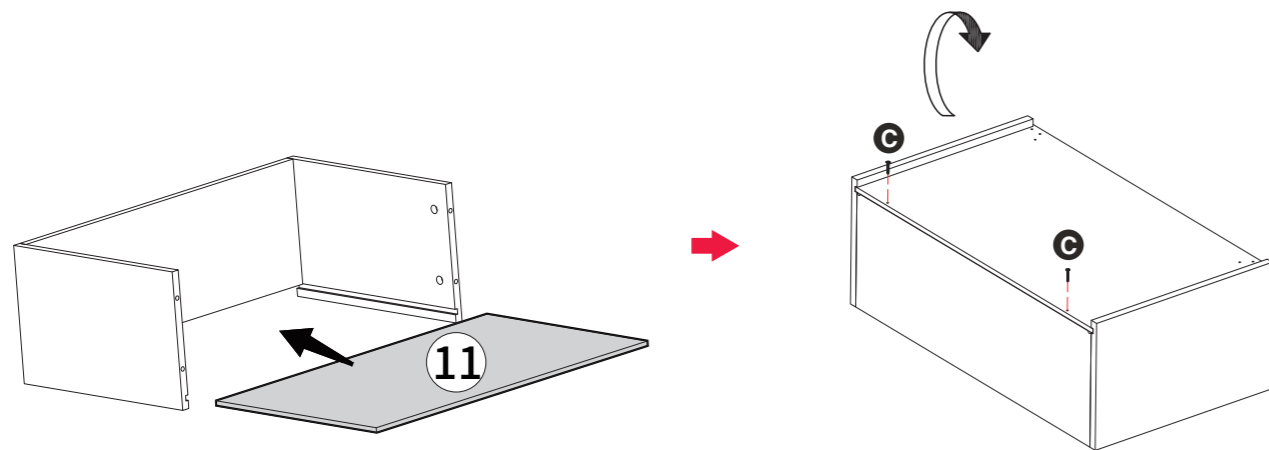
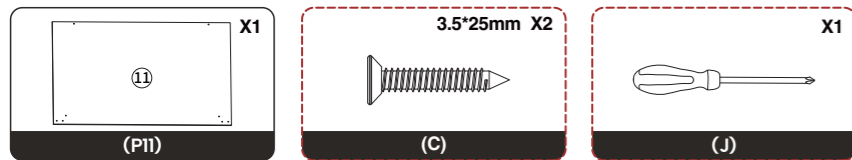

ASSEMBLY INSTRUCTIONS

INSTRUCTIONS DE MONTAGE

INSTRUCCIONES DE MONTAJE

安装步骤

STEP 1

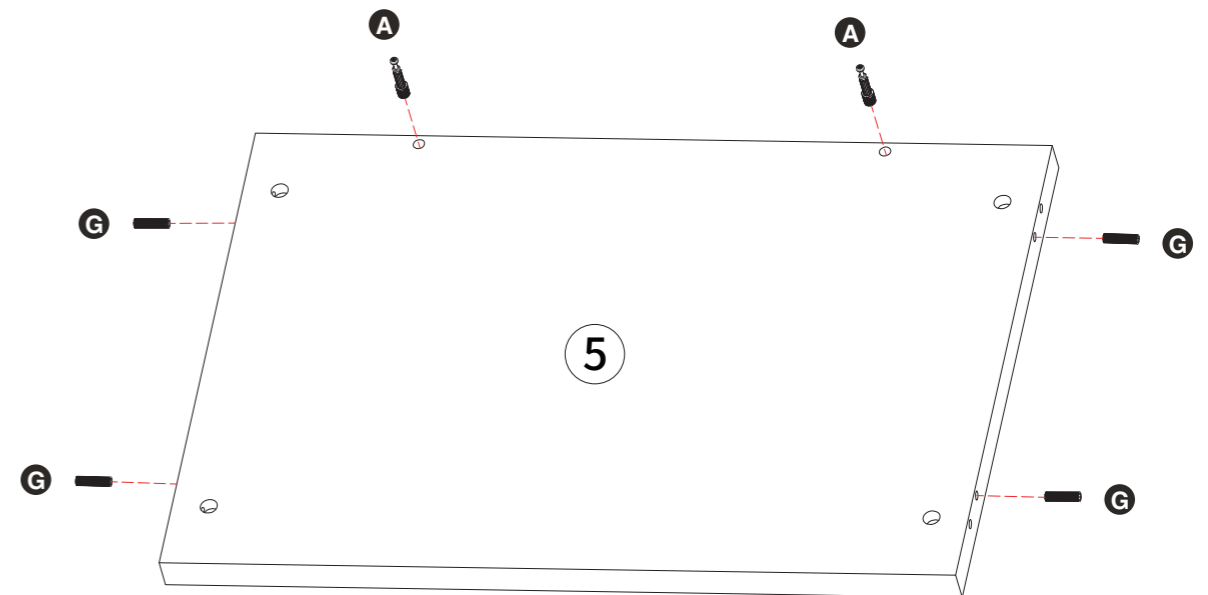
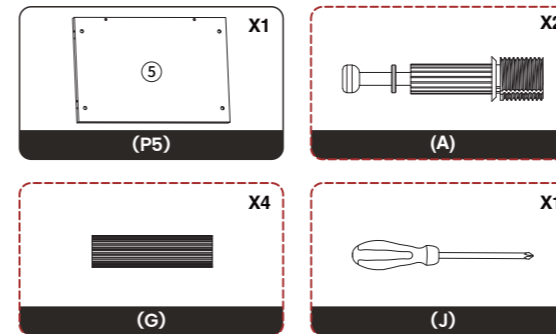

STEP 2

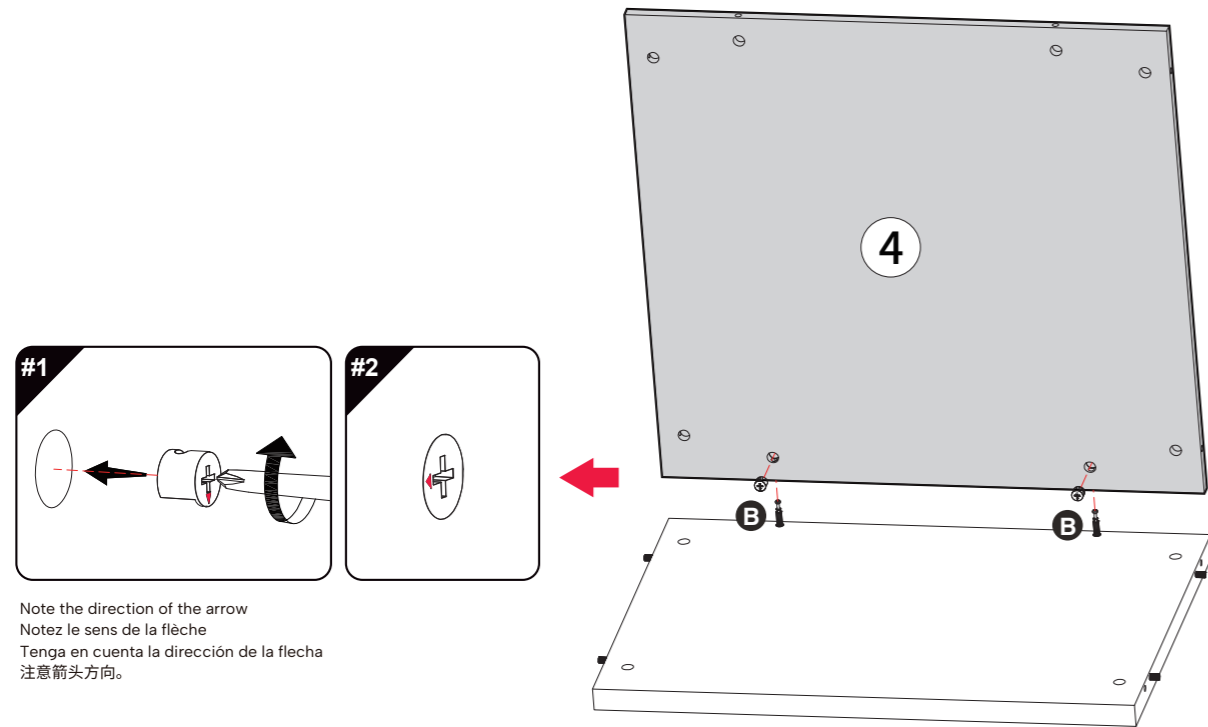
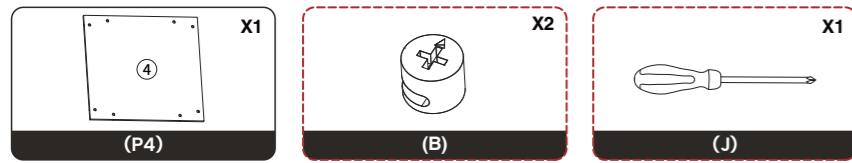

STEP 12

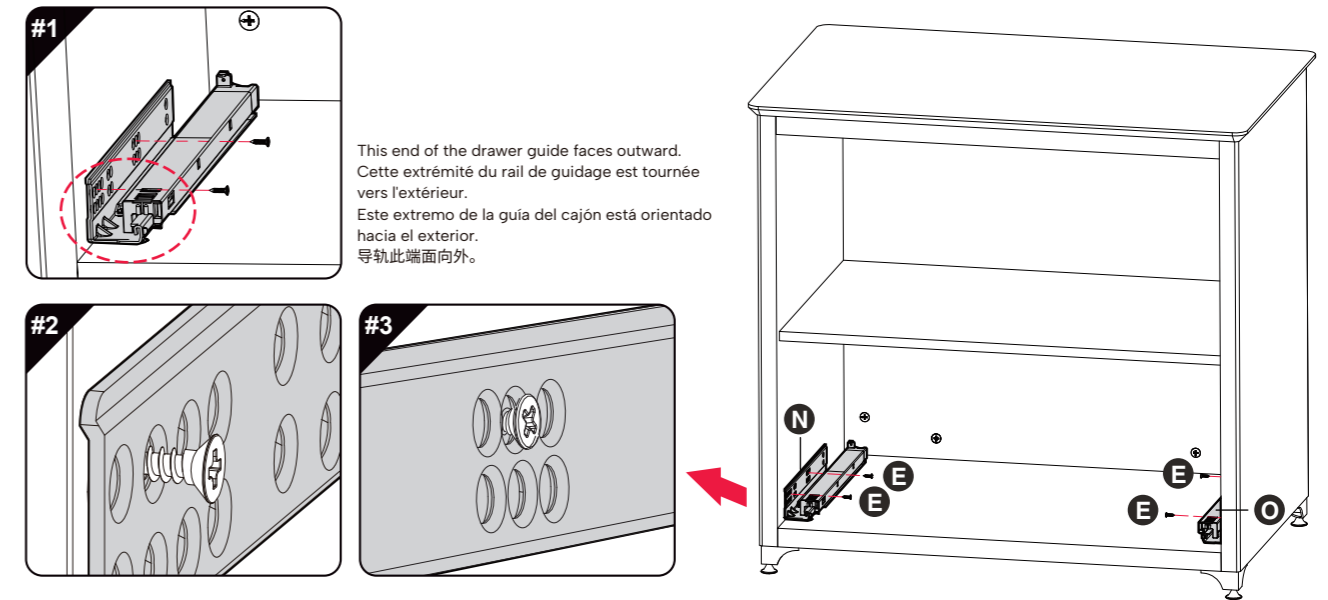
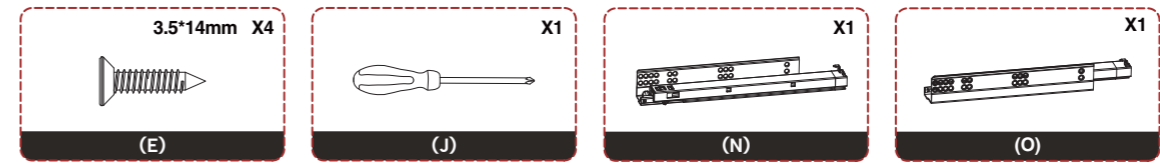

STEP 3

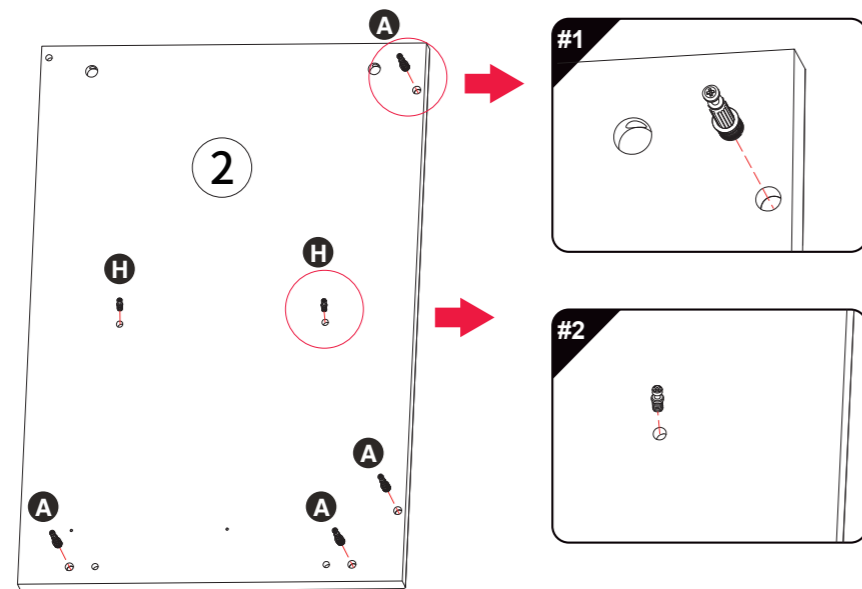
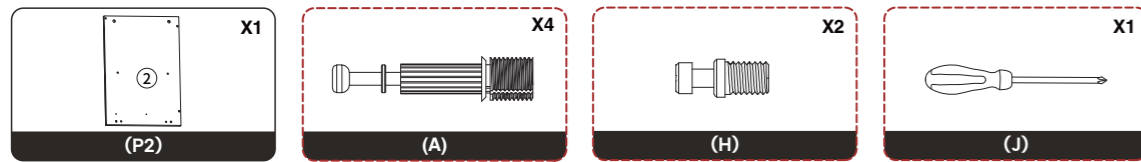

STEP 13

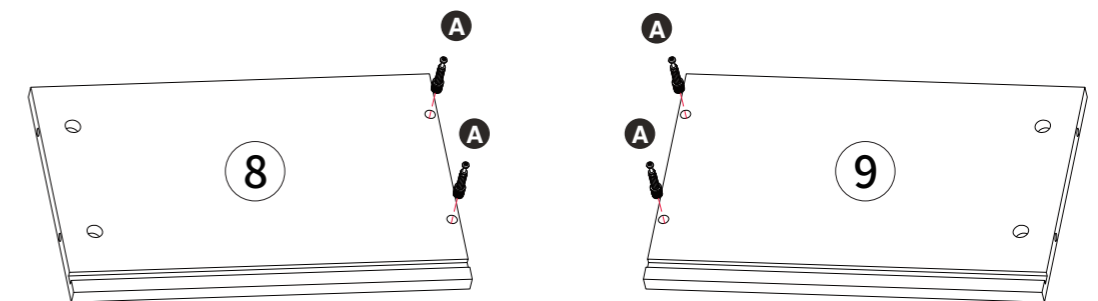
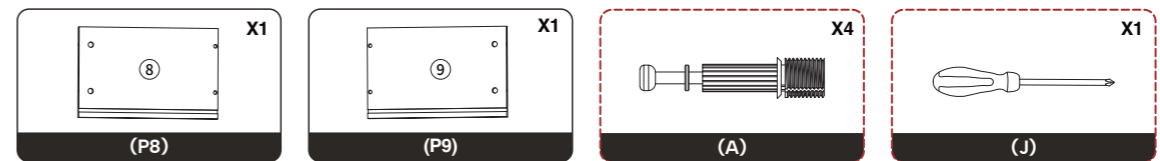

STEP 10

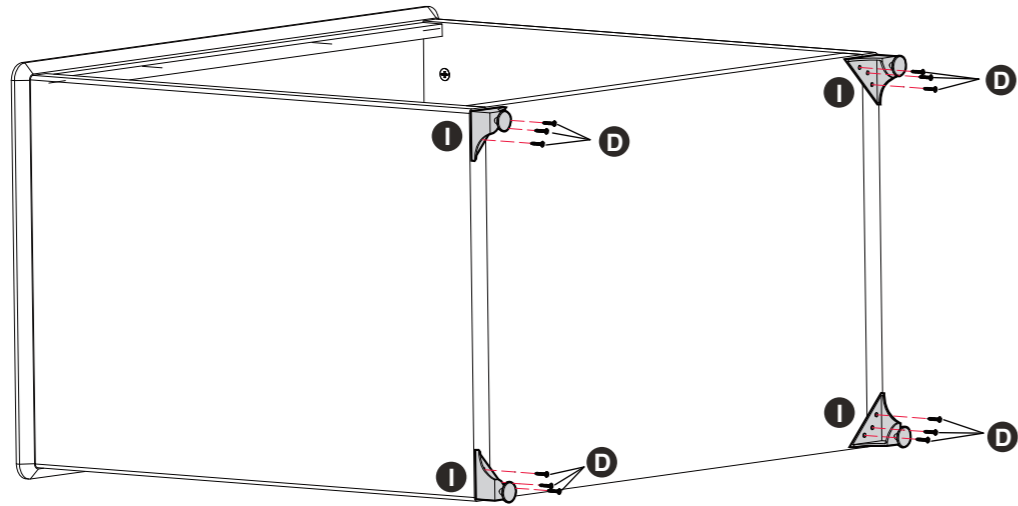
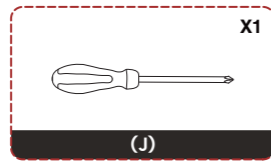
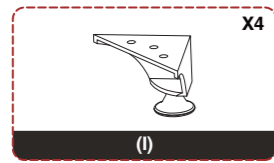
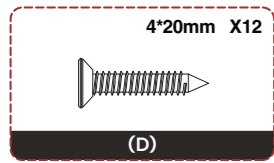

STEP 11

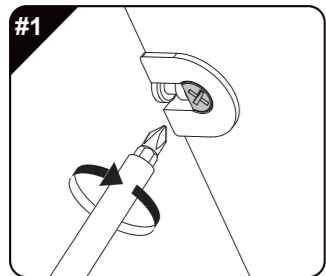
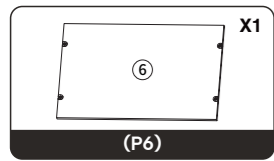

Tighten it by clockwise about 80°.
Serrez-le dans le sens des aiguilles d'une montre à environ 80°.
Apriételo en el sentido de las agujas del reloj unos 80°.
旋转约80°拧紧。

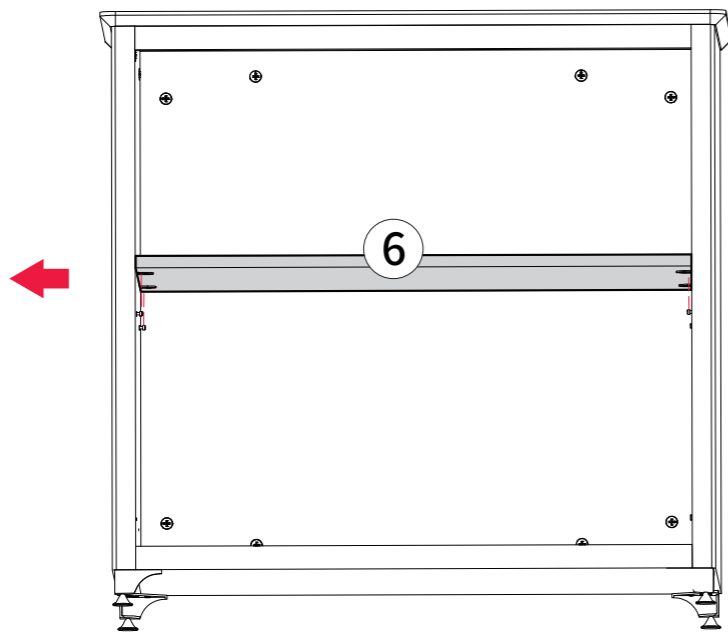

STEP 4

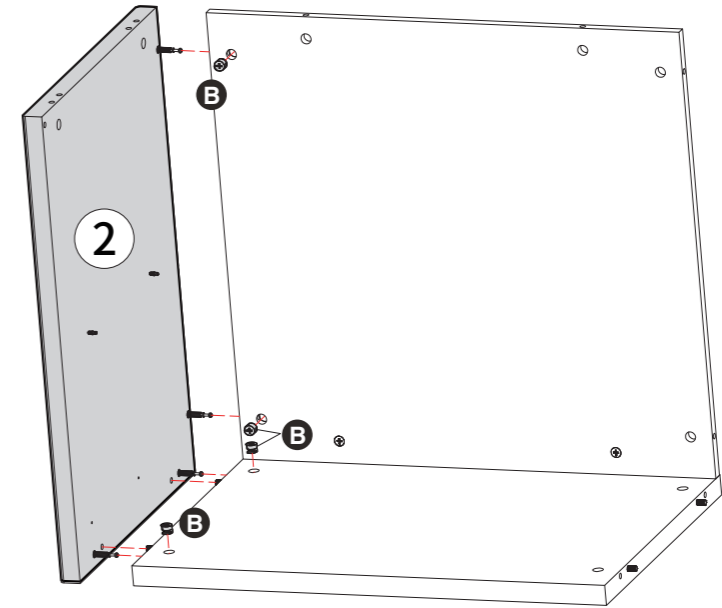
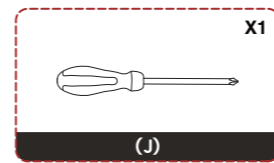
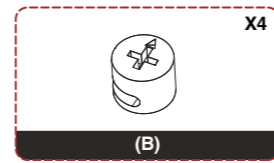

STEP 5

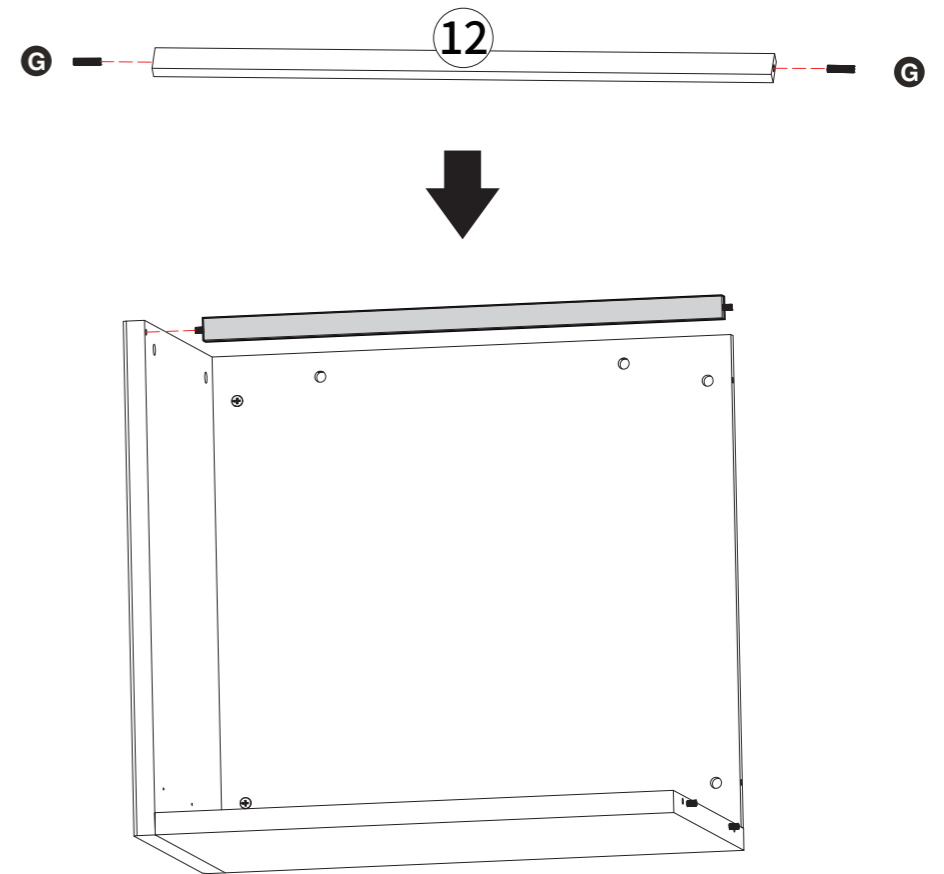
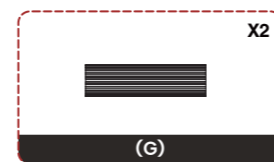
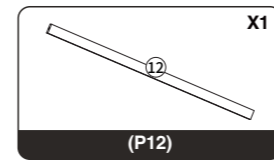

STEP 6

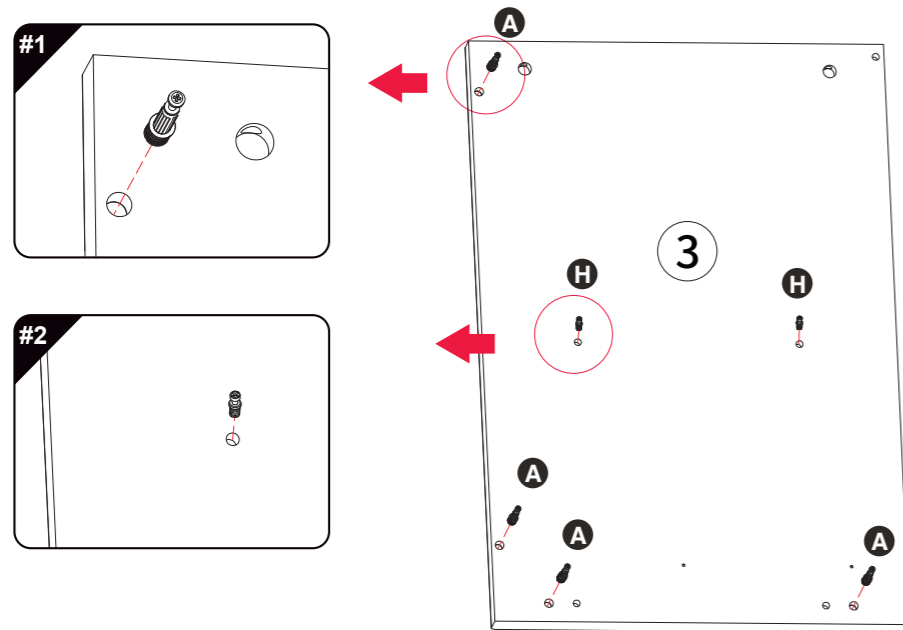
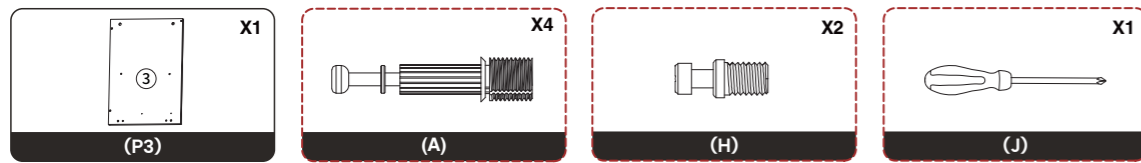

STEP 7

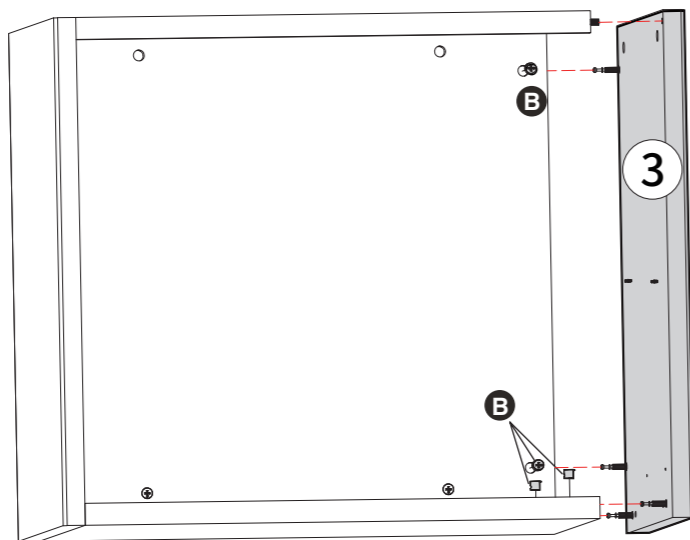
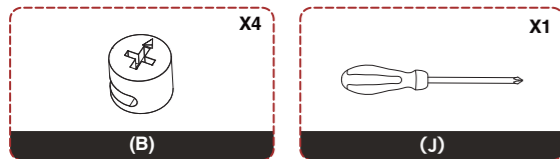

STEP 8

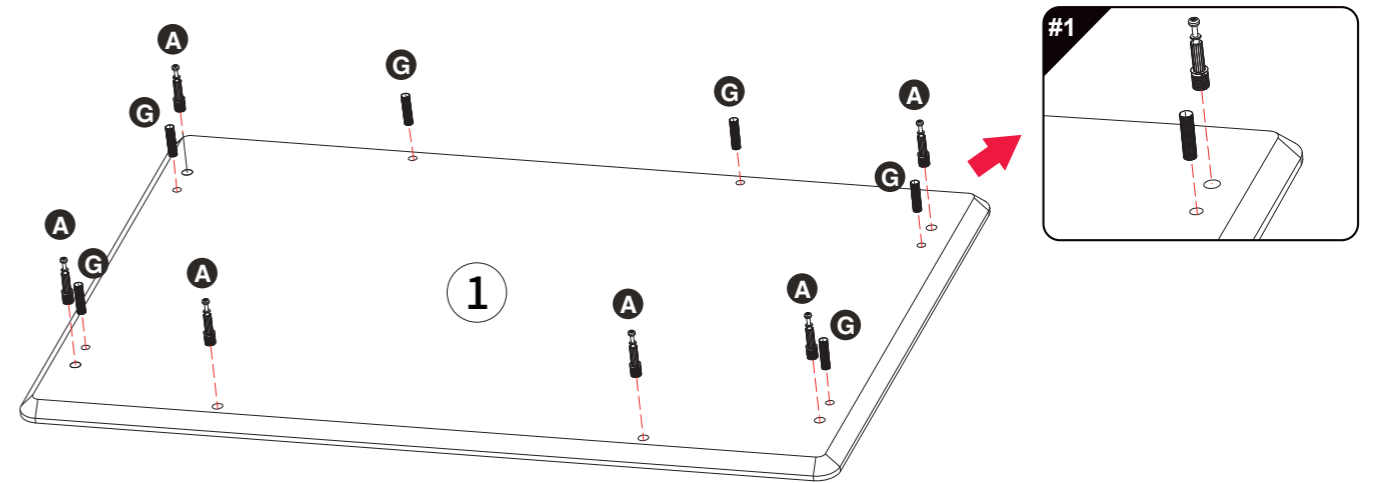
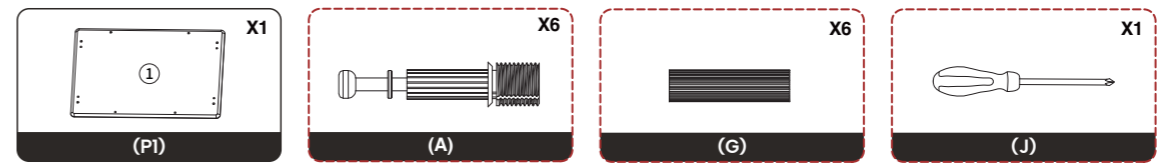

STEP 9

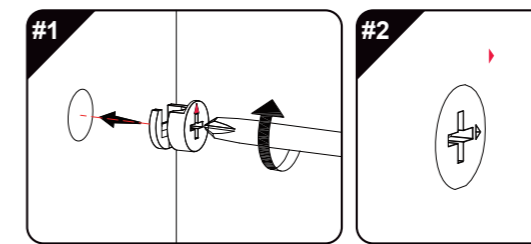
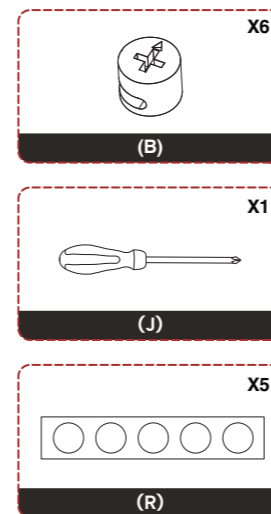

Note the direction of the arrow
 Notez le sens de la flèche
 Tenga en cuenta la dirección de la flecha
 注意箭头方向。

