

# TABLE ASSEMBLY INSTRUCTION

STEP 1: FIX LEG INTO CENTRE COLUMN WITH ITEM (A), (B) (C) USING ITEM (D)

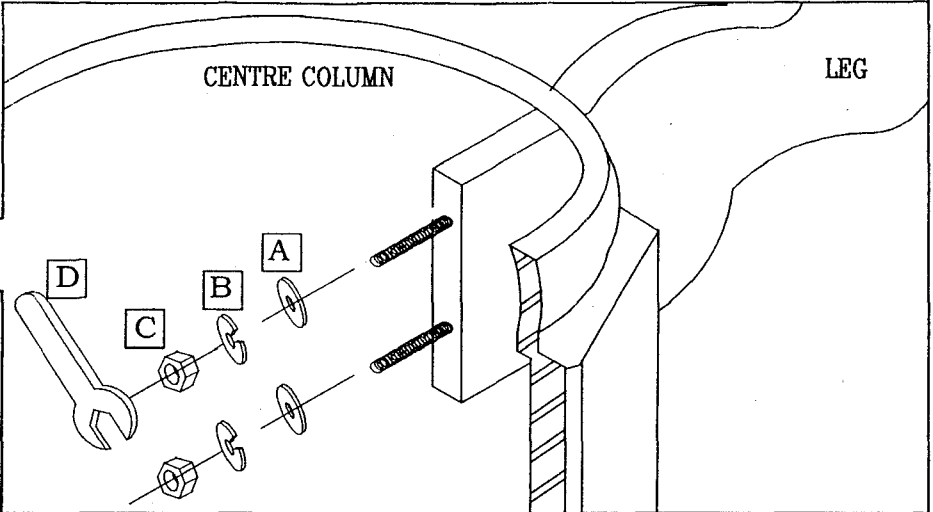

STEP 2: PULL OUT THE SIDE TOP. FIX BASE ONTO CENTRE COLUMN WITH ITEM (A), (B), (C) USING ITEM (D)

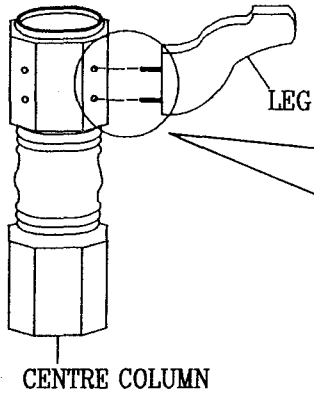
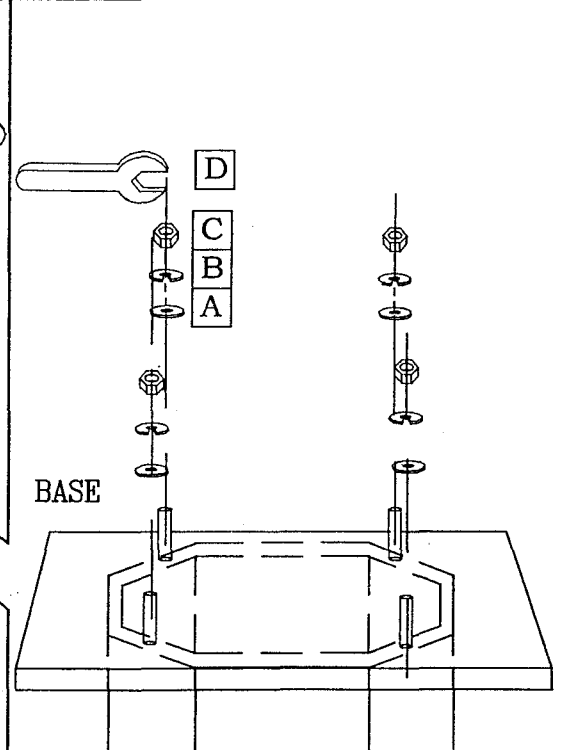
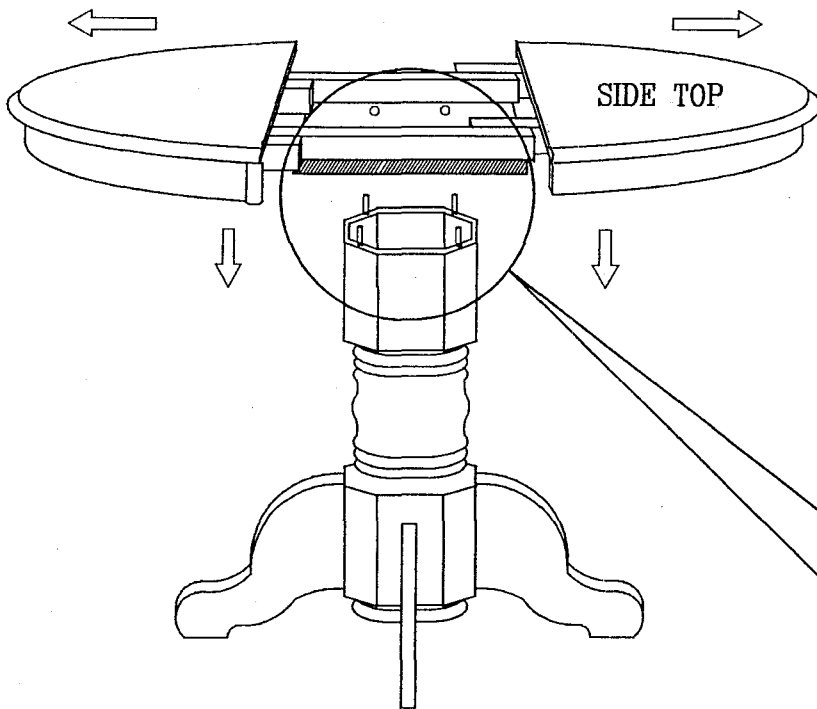



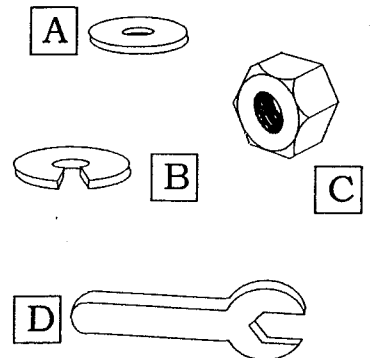
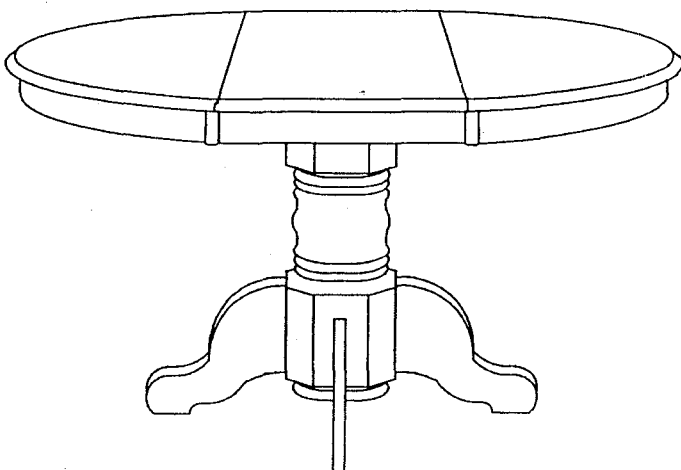

COMPLETE TABLE



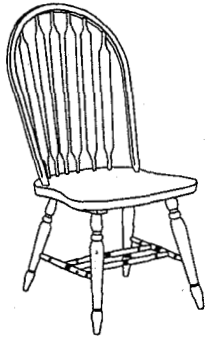

ITEM	QTY.	DESCRIPTION
A	12	WASHER
B	12	SPRING WASHER
C	12	HEX NUT
D	1	WRENCH

Model : Arrowback Windsor Chair

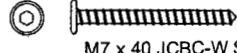
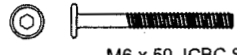

No.	Parts List (1 Chair)	Qty.
P1.	 Seat	1 pc.
P2.	 Leg Frame	2 pcs.
P3.	 Front Stretcher	1 pc.
P4.	 Back Stretcher	1 pc.

No.	Hardware List (1 Chair)	Qty.
H1.	 M4 Allen Key	1 pc.
H2.	 M7 x 40 JCBC-W Screw	6 pcs.
H3.	 M6 x 50 JCBC Screw	2 pcs.
H4.	 Barrel Nut	2 pcs.
H5.	 Wood Button	2 pcs.

**STEP 1**

Assemble Front Stretcher (P3) & Back Stretcher (P4) to the Leg Frame (P2). Fix it by using Barrel Nut (H4) and JCBC Screw (H3) as shown. Then tighten it up with Allen Key (H1).  
 \*Do not fully tighten the screw until final step.

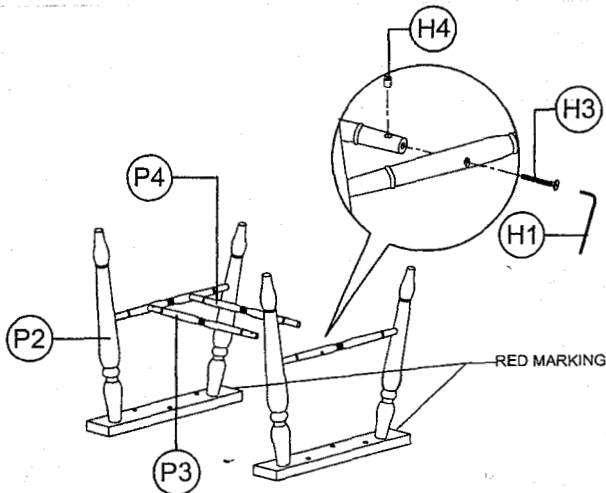

**STEP 2**

Assemble the Leg Frame to the Chair Seat (P1) with JCBC-W (H2). Then tighten it up with Allen Key (H1). **RED MARKING** on the Leg Frame should facing **BACK**

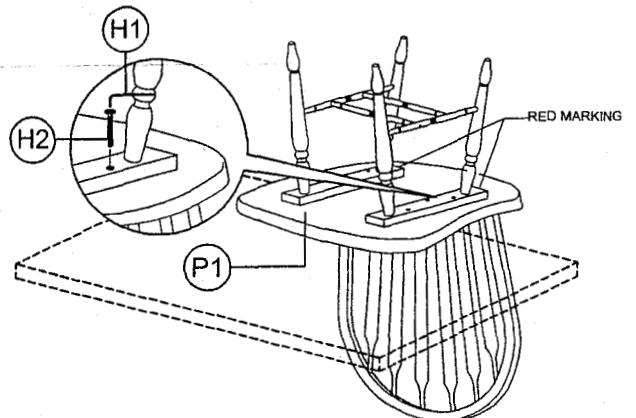

**STEP 3**

Pull the back legs inwards to ensure full connection between Leg Frame (P2) and Front Stretcher (P3).

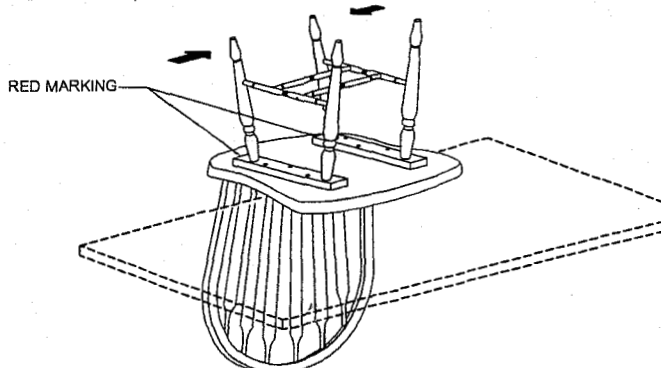

**STEP 4**

Make sure all legs are level. Once level, tighten up all the screws. Cover the screw holes with Wood Button (H5).

