

INSTRUCTIONS INSTRUCTION ANWEISUNG

사용설명서
取扱説明書

LIBRO DE INSTRUCCIONES LSTRUZIONI PER L'INSTALLAZIONE

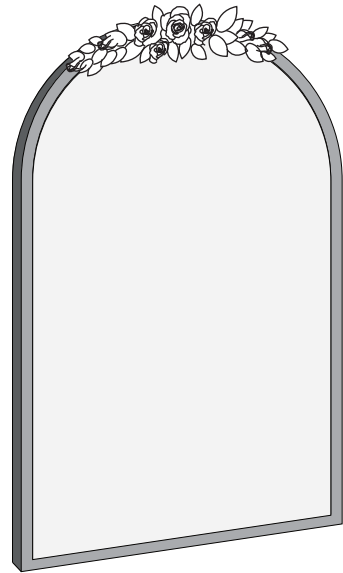

Product Name: Art mirror
YSJ-Z113-S

Manufacturer: Yingbo Luo

Address: Tangkengwei Tangguang Village,
Tangnan Town, Fengshun County, Meizhou,
Guangdong 514300

REPÚBLICA POPULAR DE CHINA

Country of origin: Made in China

Email: Artloge@wisfor.com

Warning:

Fragile items, handle with care

Zerbrechlich - Vorsichtig behandeln

Fragiles, Manipuler avec precaution

Fragile, maneggiare con cura

Frágil, manipular con cuidado

壊れやすい製品なので、丁寧に扱ってください。

깨지기 쉬운 물건이니 조심히 다루세요.



C&E Connection
E-Commerce (DE) GmbH
Zum Linnegraben 20, 65933,
Frankfurt am Main, Germany
info@ce-connection.de



Company: YH Consulting Limited
Address: C/O YH Consulting Limited Office 147,
Centurion House, London Road,
Staines-upon-Thames, Surrey, TW18 4AX



*Two people for assembly
*Instalieren zwei Personen zusammen
*2人作業が必要です
*Deux personnes pour l'assemblage
*조립을 위해 두 사람 필요
*Due persone per il montaggio
*Dos personas para el montaje

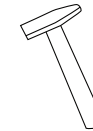
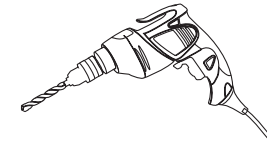
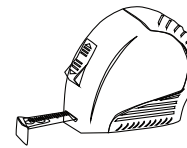

1. Please prepare all the shown tools before installation.
2. Strongly recommend that two people for assembling as the mirror is heavy.

1. Bitte bereiten Sie die oben genannten Werkzeuge vor der Installation vor.
2. Der Spiegel ist schwer, bitte zwei Personen, um die Installation zu erledigen.

1. 鏡を取り付ける前に、上の工具を予め用意ください。
2. 鏡が重いので、2人で取り付けることを進めます。

1. Avant d'installer le miroir, préparez les outils d'installation
2. Il est recommandé que deux personnes installent ensemble

1. 거울을 설치하기 전에 사용할 설치 도구를 미리 준비해 두십시오.
2. 거울이 무거우니 두사람이 함께 설치하는 것을 권장합니다.

1. Si prega di preparare tutti gli strumenti mostrati prima dell'installazione.
2. Si consiglia vivamente di montarlo in due persone perché lo specchio è pesante.

1. Por favor, prepare todas las herramientas mostradas antes de la instalación.
2. Se recomienda encarecidamente que dos personas monten ya que el espejo es pesado.

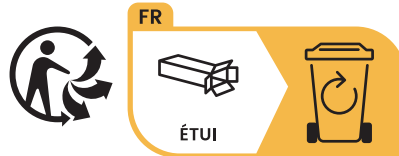

FR
Ce meuble se recycle,
s'il n'est plus utilisable
déposez-le en déchèterie.
Notice à trier:
Pour en savoir plus:
www.quefairedemesdechets.fr



Screws *2
Schrauben *2
ネジ *2
Vis *2
나사 *2
Viti *2
Tornillos *2

1

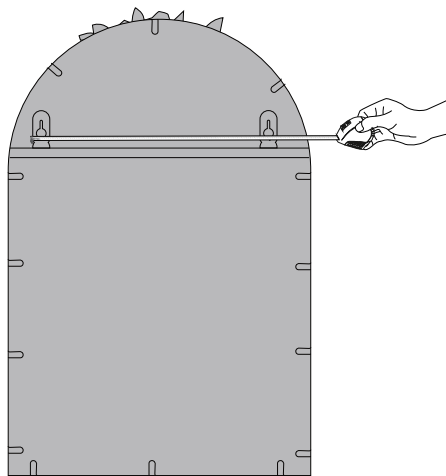

1. Measure the distance of mirror hook with a tape measure

1. Messen Sie mit einem Lineal den Abstand des Hakens hinter dem Spiegel

1. 鏡背面の2つのフックの距離を測ります。

1. Mesurez la distance entre les crochets derrière le miroir

1. 거울 뒷면 걸쇠의 거리를 자로 재십시오.

1. Utilizzare un metro a nastro per misurare la distanza tra i ganci dello specchio.

1. Mida la distancia del gancho del espejo con una cinta métrica.

2

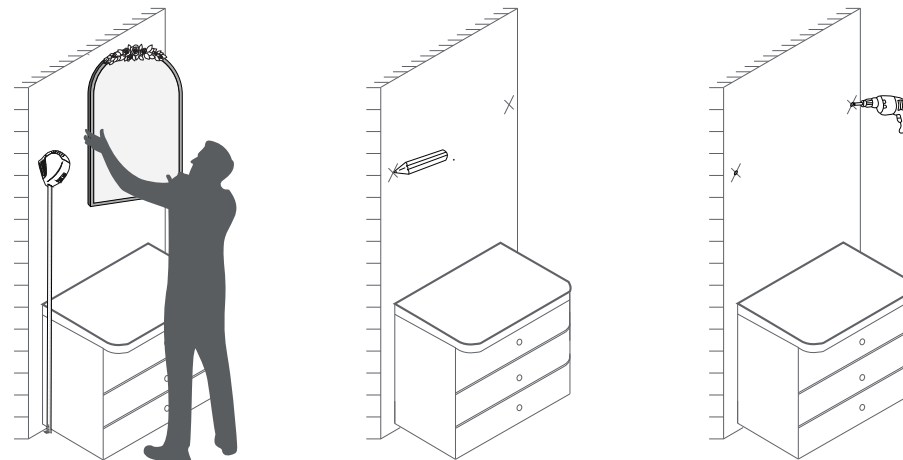

2. Measure the best installation height, mark with a pencil and drill the marks

2. Bestätigen Sie die Höhe und markieren Sie sie mit einem Bleistift

2. 壁面の希望の高さに鉛筆でネジ穴の位置をマーキングして、電動ドリルを使って、下穴を開けます。

2. Confirmez la hauteur d'installation du miroir, marquez avec un crayon et percez des trous

2. 맞은 높이를 확인하고 연필로 표시를 하고 구멍을 뚫으십시오.

2. Misurare l'altezza migliore di installazione, segnare con una matita e trapanare i segni.

2. Mida la mejor altura de instalación, marque con un lápiz y taladre las marcas.

3

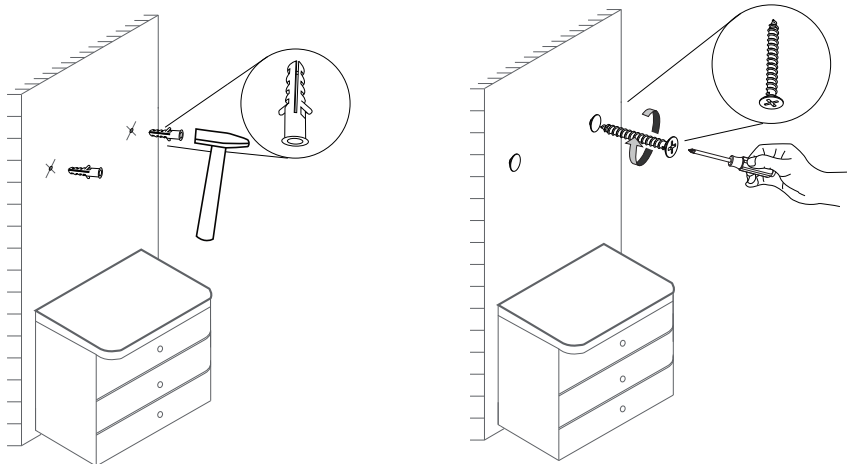

3. Drive the screws and hooks into the hole

3. Schrauben und Haken eindrehen

3. ネジとフック締めます。

3. Visser les vis et les crochets

3. 나사와 후크를 비틀어 넣으십시오.

3. Inserisci le viti e i ganci nel foro.

3. Introduce los tornillos y ganchos en el agujero.

4

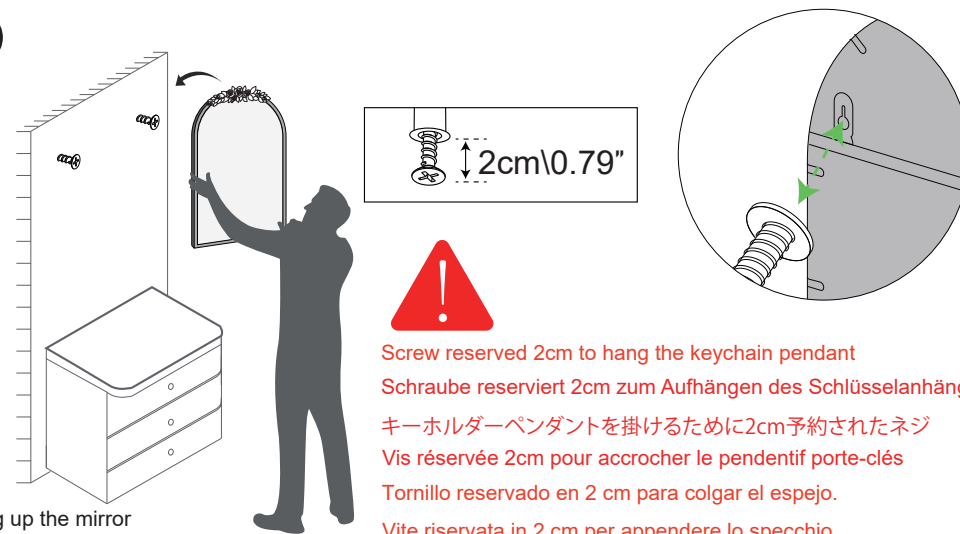

4. Hang up the mirror

4. Hängen Sie den Spiegel

4. 鏡を壁に掛けます。

4. Accrochez le miroir

4. 거울을 걸고

4. Appendere lo specchio

4. Cuelga el espejo

2cm\0.79"



Screw reserved 2cm to hang the keychain pendant

Schraube reserviert 2cm zum Aufhängen des Schlüsselanhängers

キーホルダーペンダントを掛けるために2cm予約されたネジ

Vis réservée 2cm pour accrocher le pendentif porte-clés

Tornillo reservado en 2 cm para colgar el espejo.

Vite riservata in 2 cm per appendere lo specchio

거울을 걸기 위해 2cm에 예약된 나사