

ASSEMBLY INSTRUCTIONS



Fine Furniture for every stage of life

SHOE CABINET

ASSEMBLY INSTRUCTIONS

ASSEMBLY TIPS:

1. Remove hardware from box and sort by size.
2. Please check to see that all hardware and parts are present prior to start of assembly.
3. Please follow attached instructions in the same sequence as numbered to assure fast & easy assembly.



WARNING!





1. Don't attempt to repair or modify parts that are broken or defective. Please contact the store immediately.
2. This product is for home use only and not intended for commercial establishments.





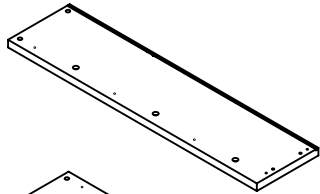
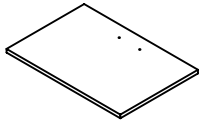
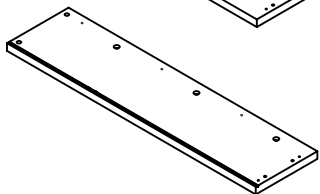

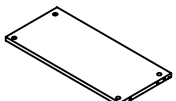
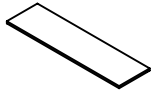
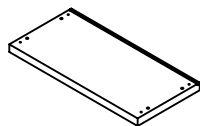
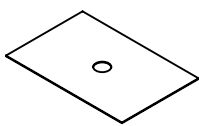

ASSEMBLY TIME

80 MINUTES

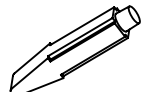
PARTS IDENTIFICATION

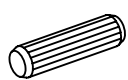
A	LEFT SIDE PANEL		1 PC	F	DOOR		3 PCS
B	RIGHT SIDE PANEL		1 PC	G	SHELF		3 PCS
C	BOTTOM PANEL		1 PC	H	PARTITION PANEL		6 PCS
D	TOP PANEL		1 PC	I	BACK PANEL		3 PCS
E	CROSS PANEL		1 PC				

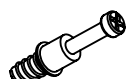
HARDWARE IDENTIFICATION











Z	NO	DESCRIPTION	FIGURE	Q'TY	NO	DESCRIPTION	FIGURE	Q'TY
	1	GLUE 15g		1 PC	4	CAM LOCK Ø 15x12mm		10 PCS
	2	WOODEN DOWEL Ø 8x30mm		10 PCS	5	PLASTIC FEET Ø 15mm		4 PCS
	3	CAM BOLT Ø 7x35.5mm		10 PCS	6	HANDLE L = 120mm		3 PCS

NOTE:

Phillips head screw driver is required in the assembly process; however, manufacturer does not provide this item.

Z

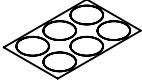
HARDWARE IDENTIFICATION

NO	DESCRIPTION	FIGURE	Q'TY	NO	DESCRIPTION	FIGURE	Q'TY
7	HANDLE BOLT Ø 4x28mm		6 PCS	13	SCREW Ø 4x15mm		18 PCS
8	PLASTIC SIDE		3 PCS	14	FIXER		6 PCS
9	LATCH-MALE		6 PCS	15	FIXER SCREW Ø 3x19mm		24 PCS
10	LATCH-FEMALE		6 PCS	16	RUBBER Ø 58mm		3 PCS
11	PLASTIC SIDE SCREW Ø 8x17mm		6 PCS	17	STICKER Ø 20mm		2 PCS
12	BOLT Ø 5x15mm		6 PCS	18	I BAR L = 533mm		1 PC

Z6,Z7,Z8,Z16 not included in blister packaging.

NOTE:

Phillips head screw driver is required in the assembly process; however, manufacturer does not provide this item.

STEP 1

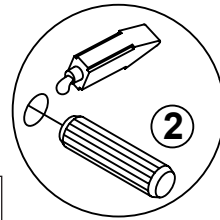
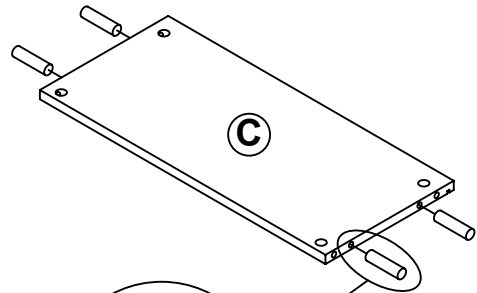
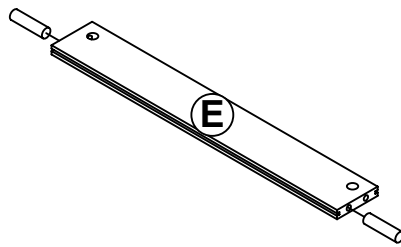
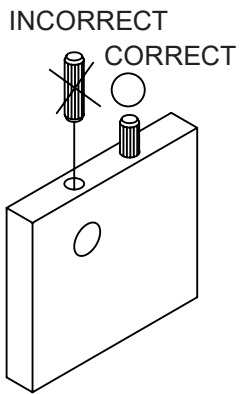
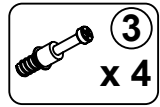
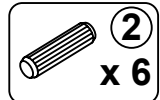
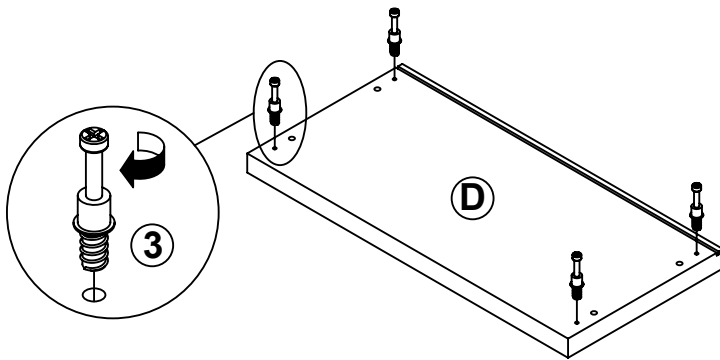

Apply glue on all wooden dowels to ensure integrity of the structure.

STEP 2

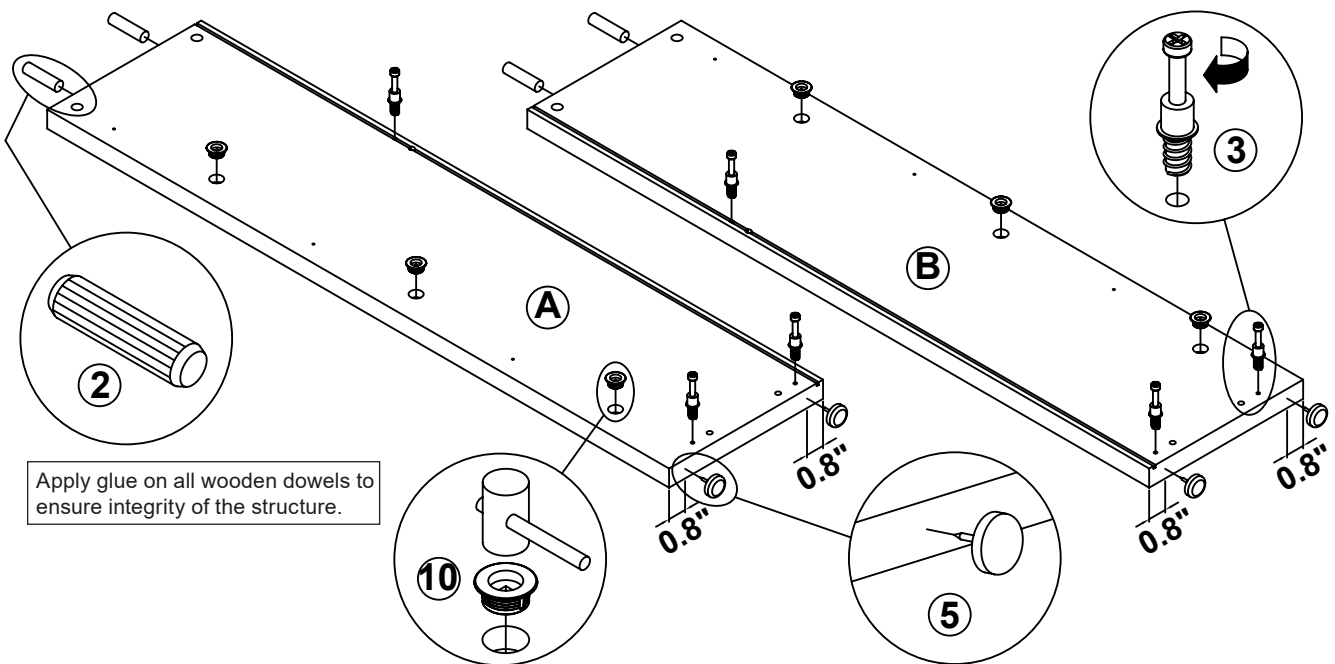
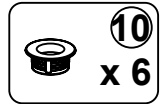
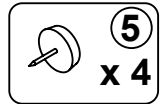
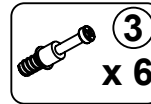
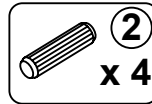

Apply glue on all wooden dowels to ensure integrity of the structure.

STEP 3

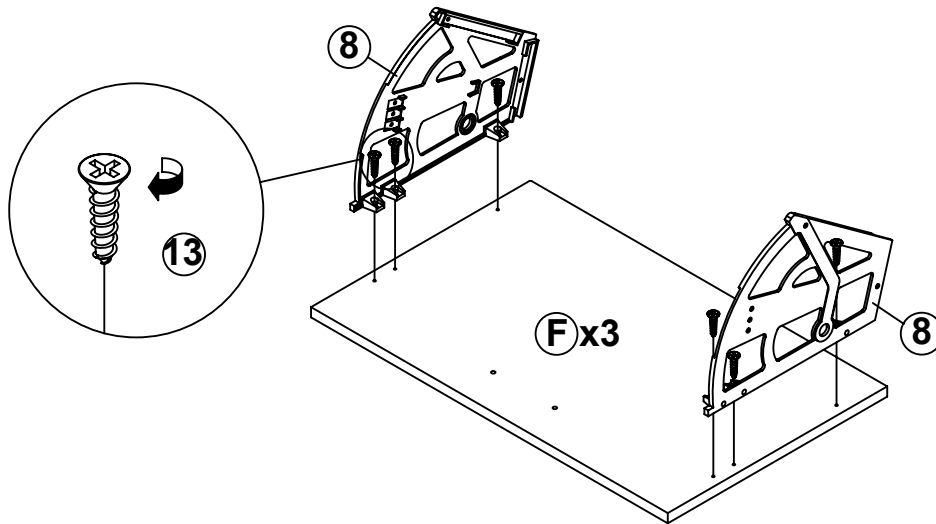
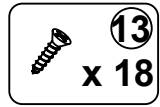
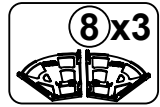

STEP 4

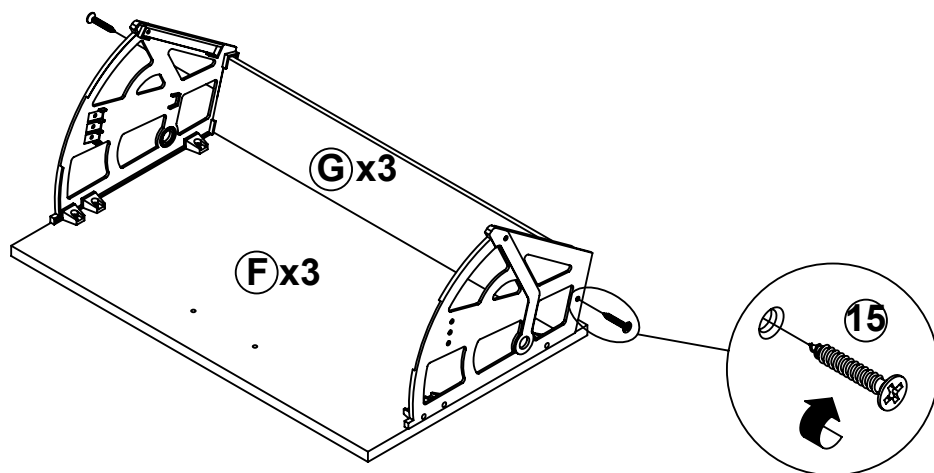
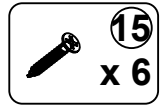

STEP 5

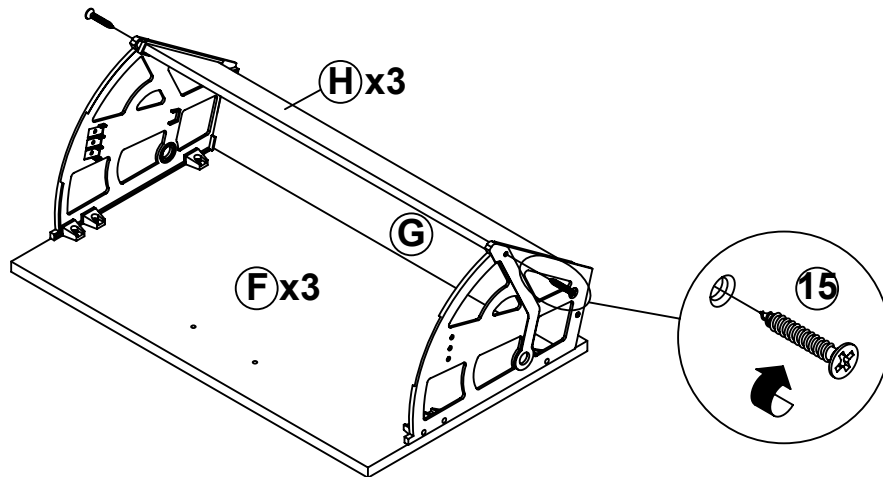
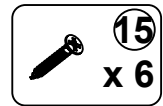

STEP 6

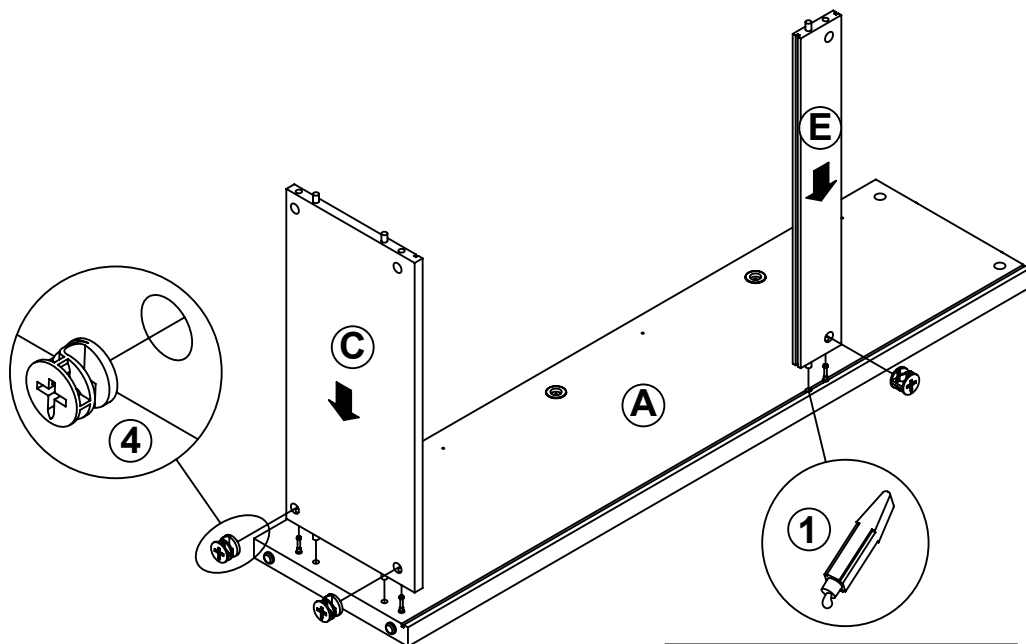
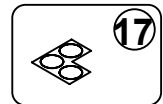
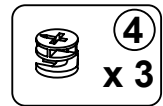

Apply glue on all wooden dowels to ensure integrity of the structure.

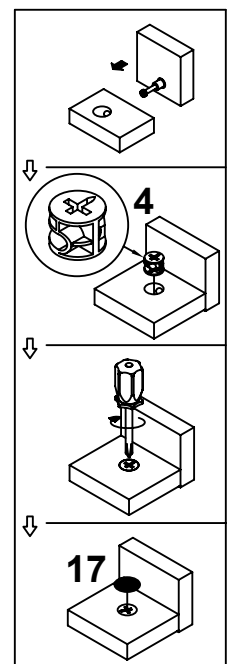

STEP 7

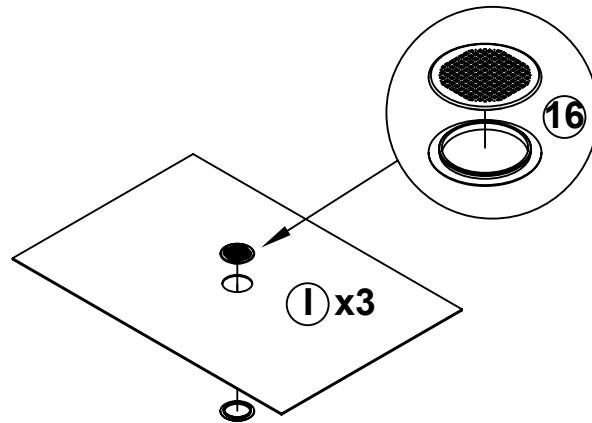
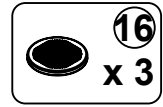

STEP 8

Apply glue on all wooden dowels to ensure integrity of the structure.

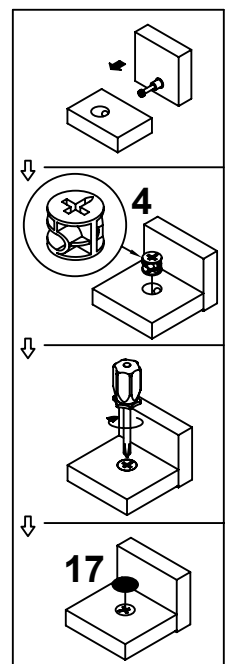
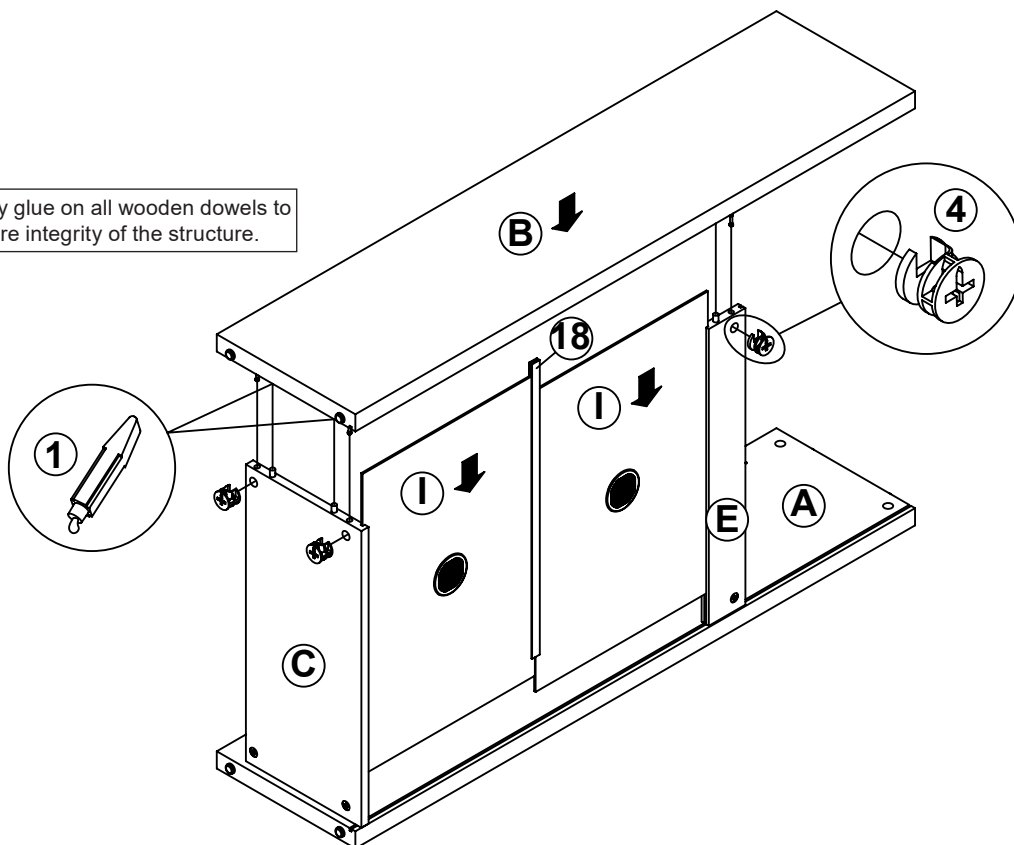
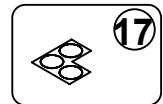
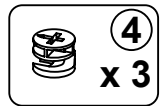

STEP 9

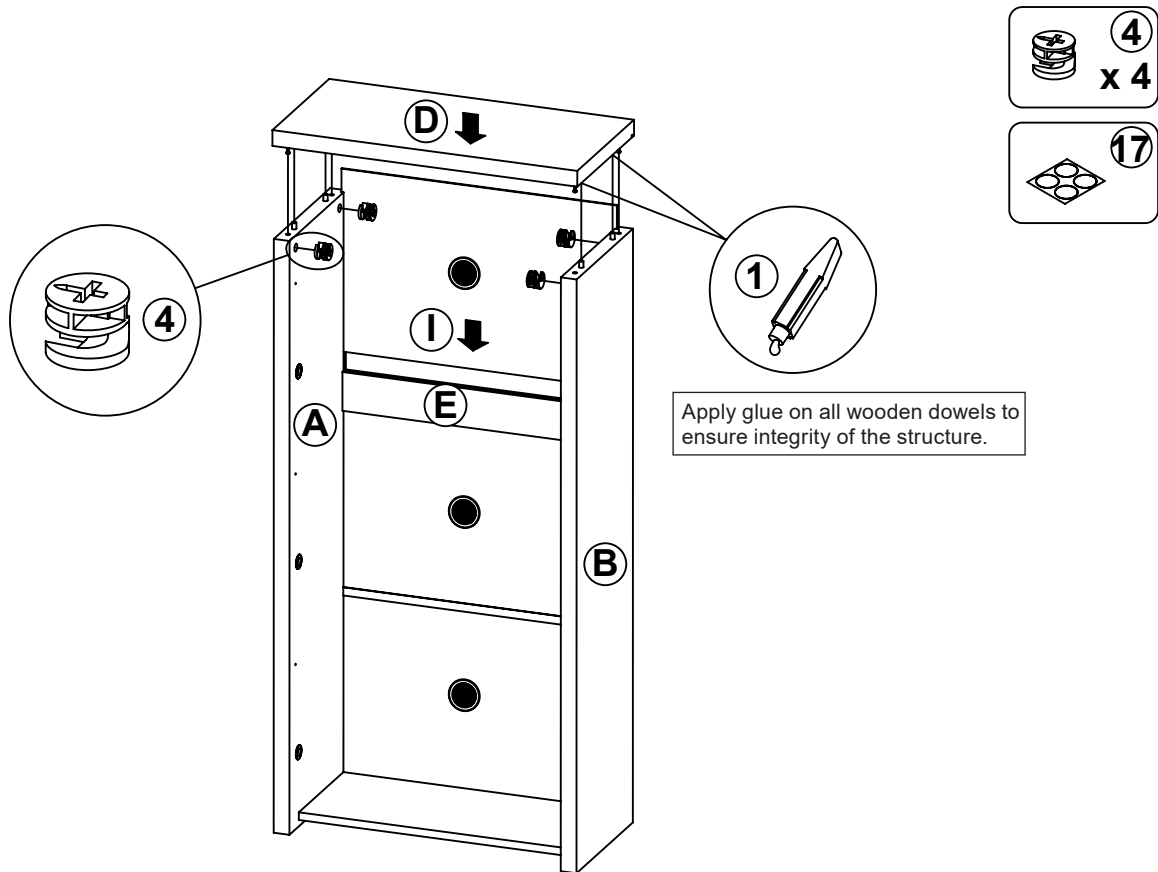

STEP 10

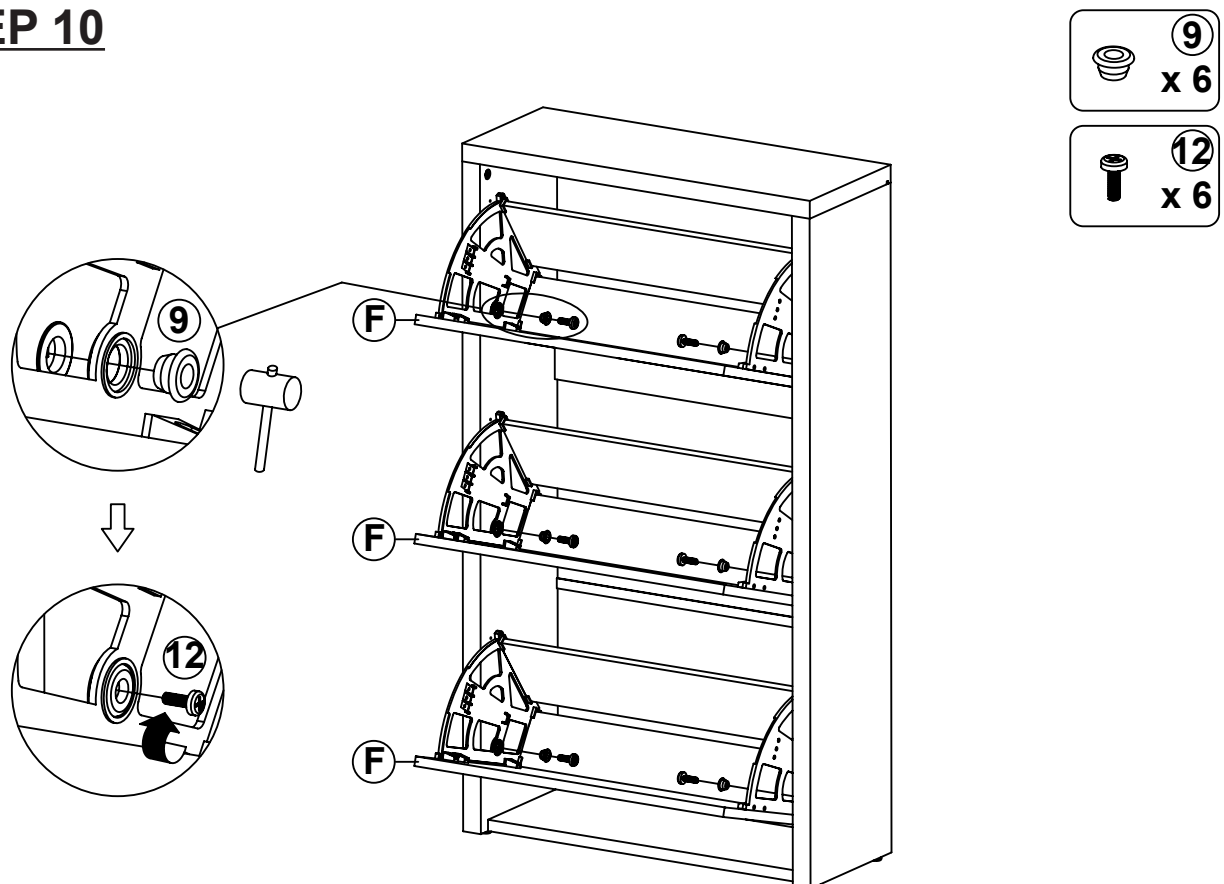

STEP 11

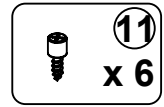
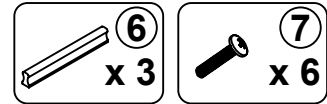
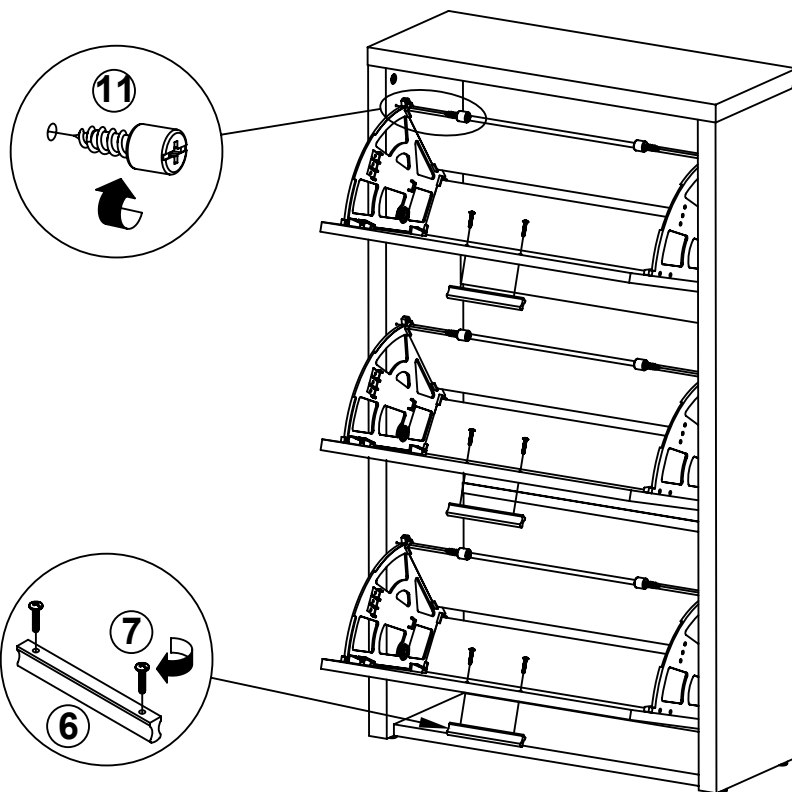

STEP 12

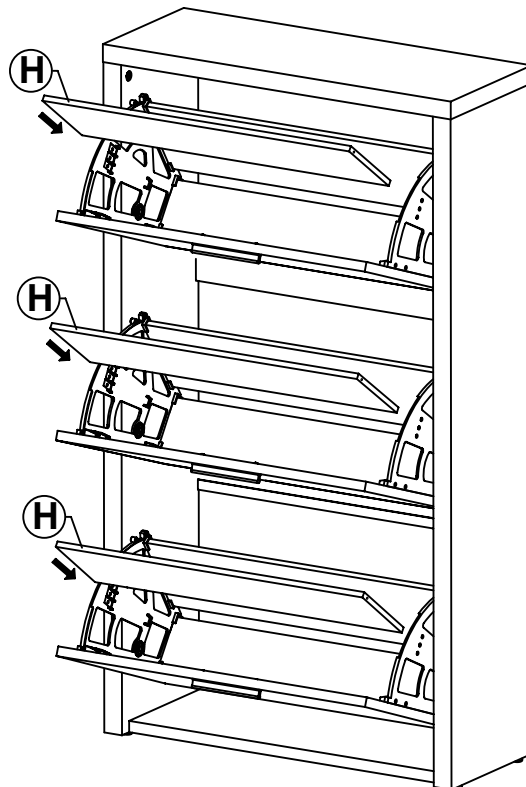

STEP 13

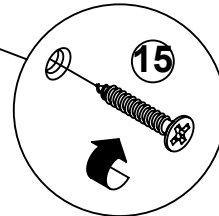
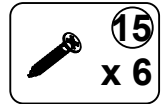
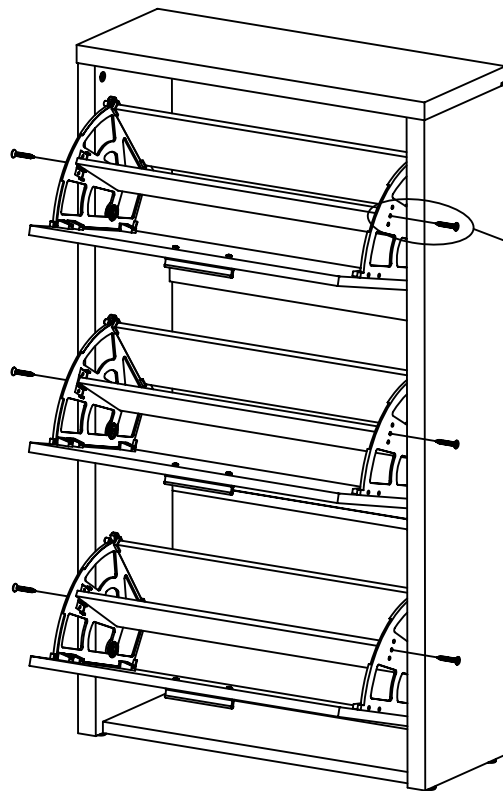

STEP 14

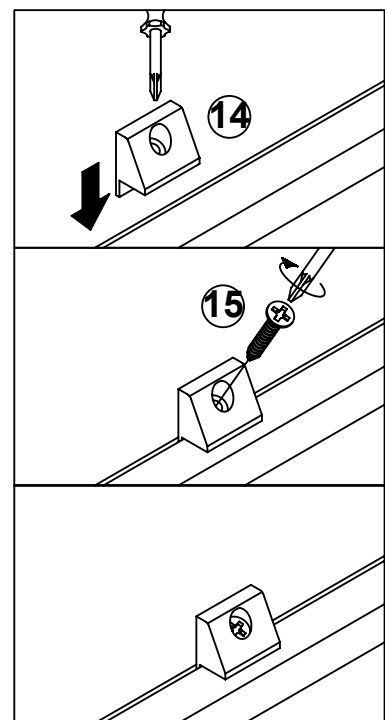
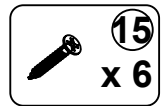
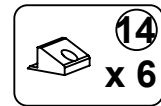
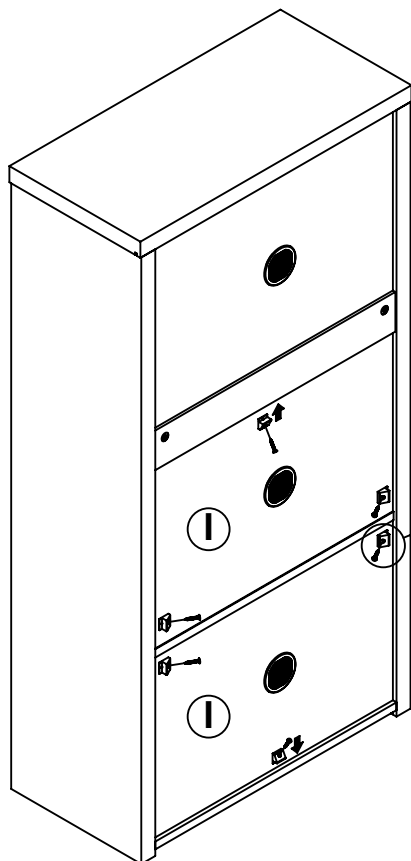

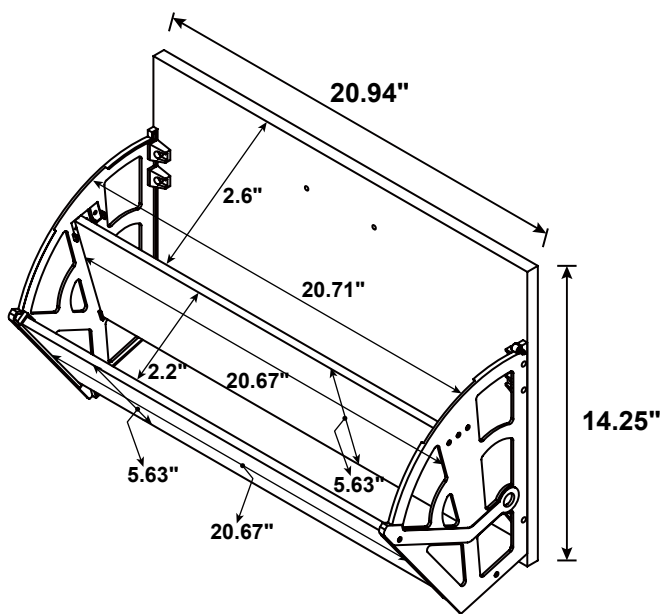
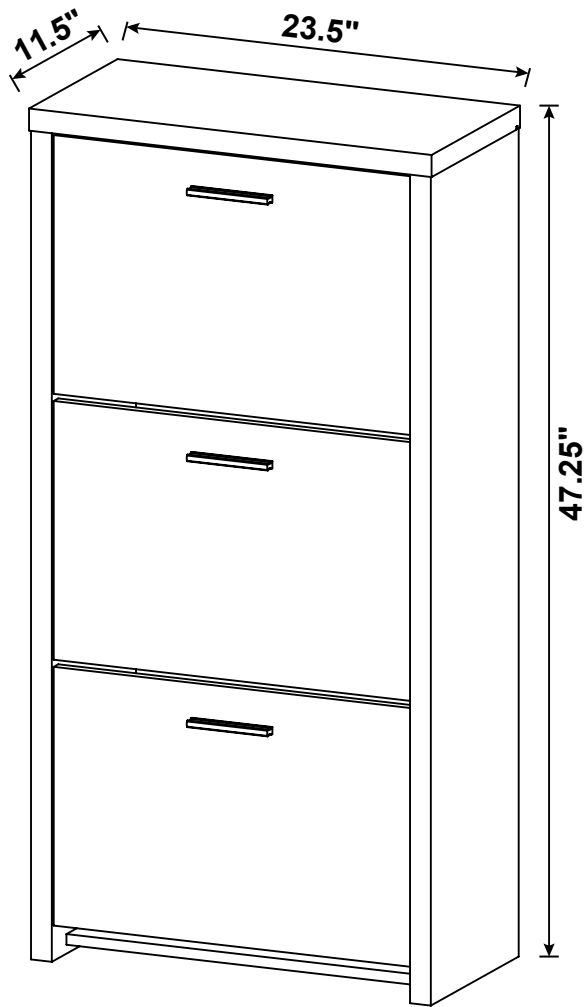

Note : Dimension tolerance $\pm 5\%$

ANTI-TIPPING INSTALLMENT INSTRUCTIONS

FURNITURE TIPPING RESTRAINT

WARNING

Injury may result from tipping furniture.
This restraint may protect against tipping furniture.
Do not allow children to climb on furniture.
This restraint is not a substitute for proper adult supervision.
Failure to detach this restraint before moving the furniture may result in injury and damage.

This restraint must be screwed to a wood stud on the wall, using the long screw provided.

STEP 1

Secure the bracket to the back top of the unit, using the short screw provided, as shown in the drawing.

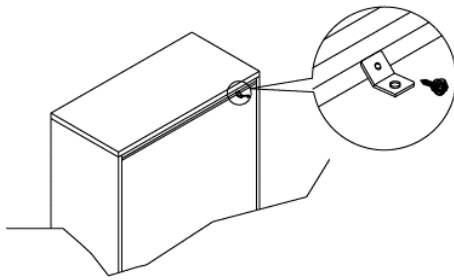

STEP 2

Locate the wood stud on the wall, and secure the other bracket, 2 inches below the back of the unit.

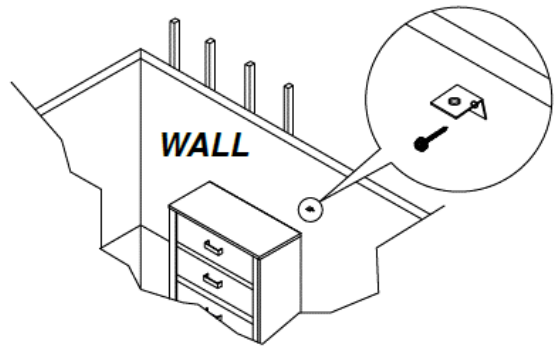

STEP 3

Place the furniture into position so both mounting brackets are vertically in line. Lace the end of the restraint strap through the larger hole in each mounting bracket. Bring both ends together and slide the flat end through the locking end, and drag it through, until the slack is removed. Ensure that the strap is securely laced and locked.

