

# ASSEMBLY INSTRUCTIONS

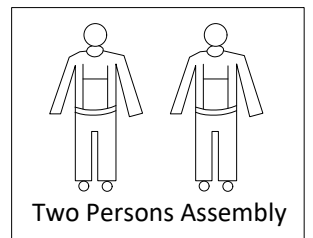

# ASSEMBLY TOOLS REQUIRED (NOT INCLUDED)

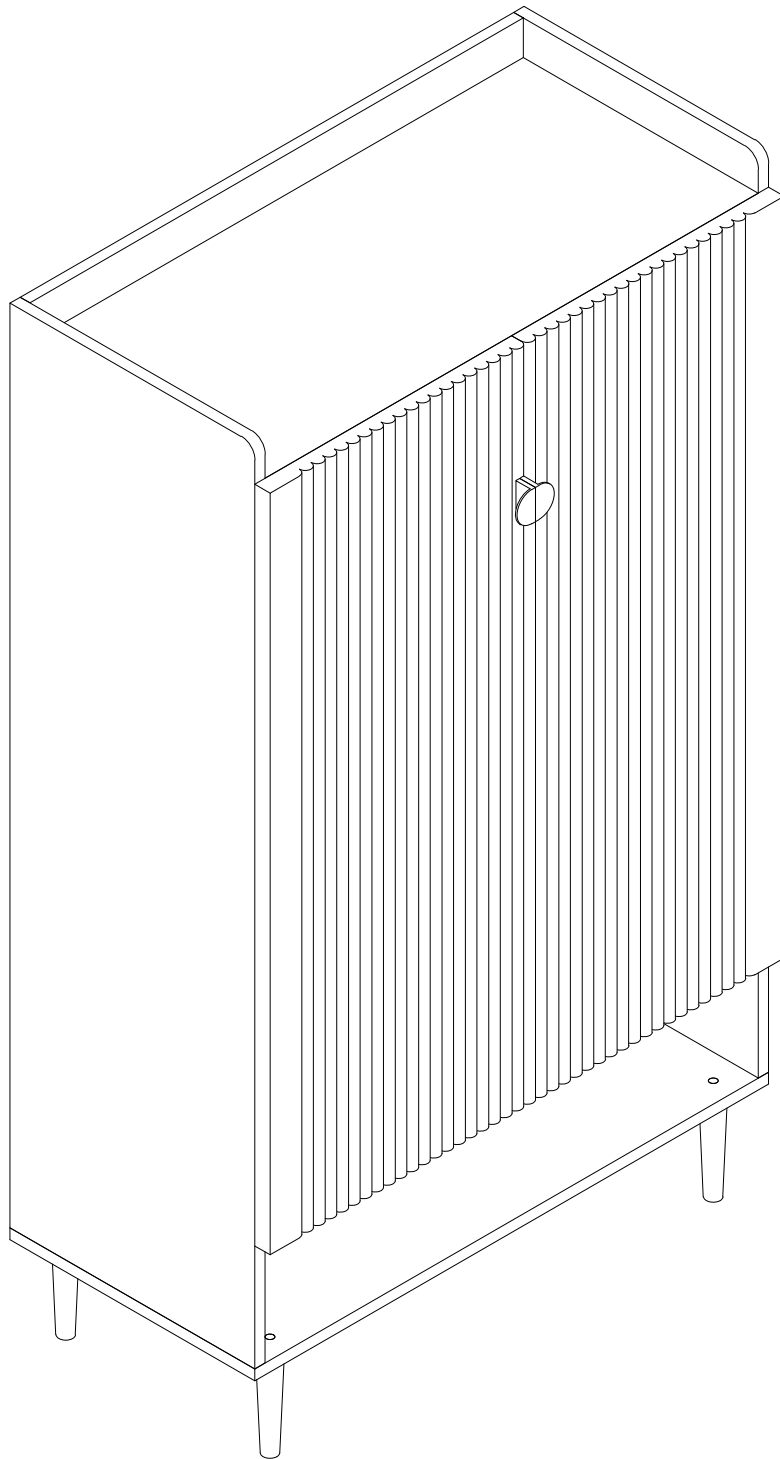
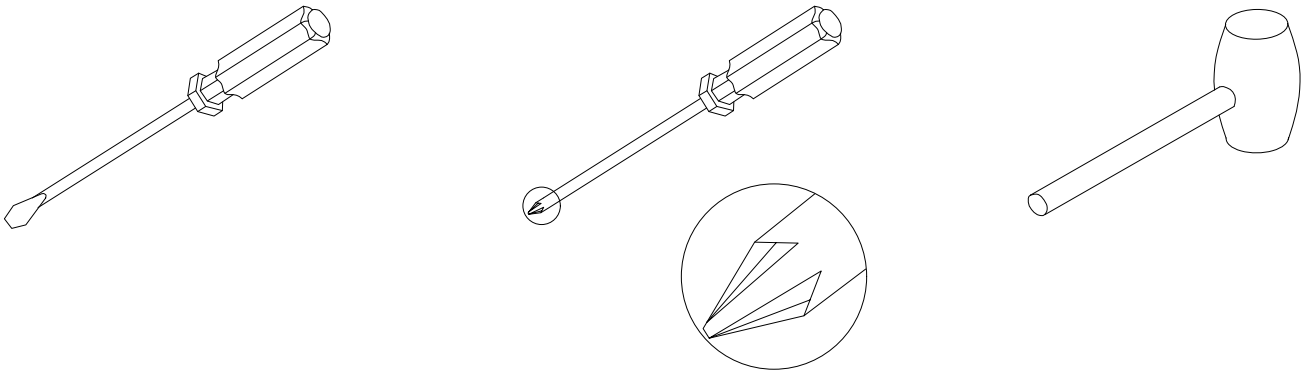

## Wooden Dowel Installation

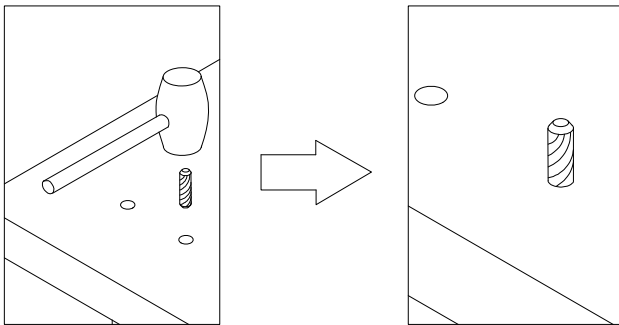

Gently tap dowel into hole with rubber mallet.

- \* Before discarding packing materials, please check all parts and hardware are presented.
- \* Please follow the instructions closely.
- \* After few days of initial assembly, the product may has acclimated to new environment, please tighten all hardware again.

## Hidden Connector..... Assembly Techniques

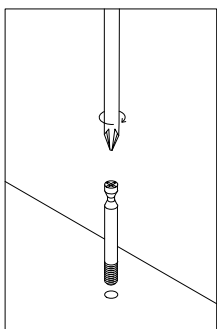

STEP (1)

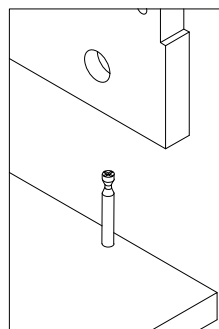

STEP (2)

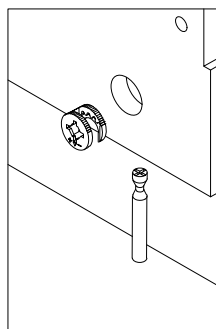

STEP (3)

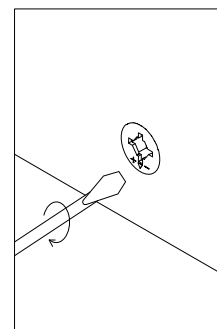

STEP (4)

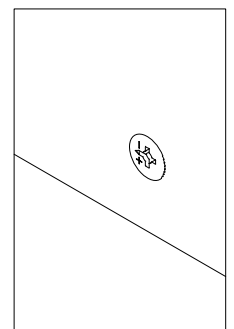

STEP (5)

**It may be necessary to adjust the hinges so that the doors align. Use the instructions below as a guide.**

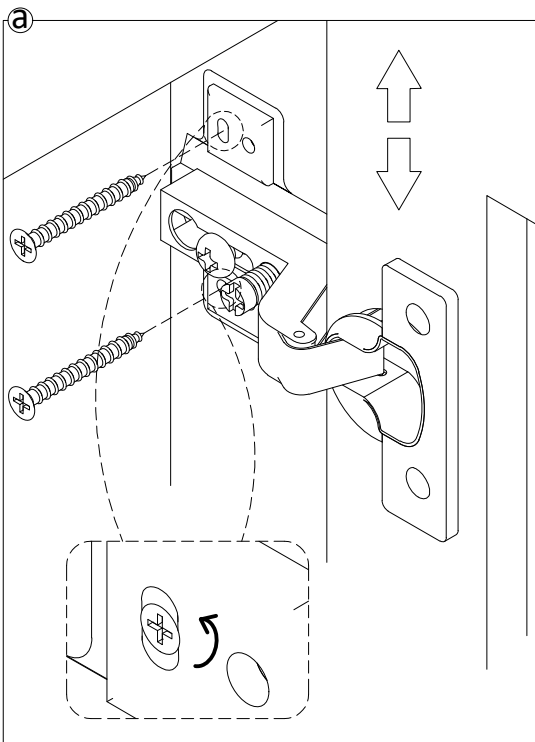

To adjust the door vertically loosen the screw as shown and move up and down as needed.

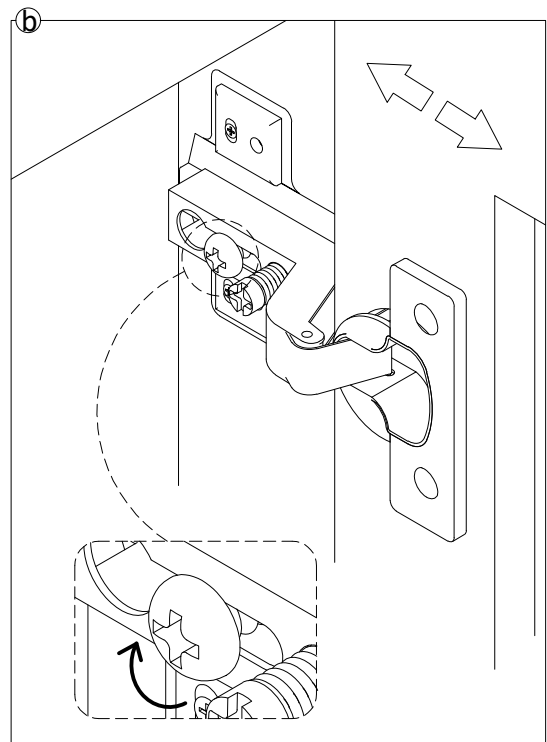

To adjust the gap from the door to the main frame turn the screw clockwise or anticlockwise as needed.

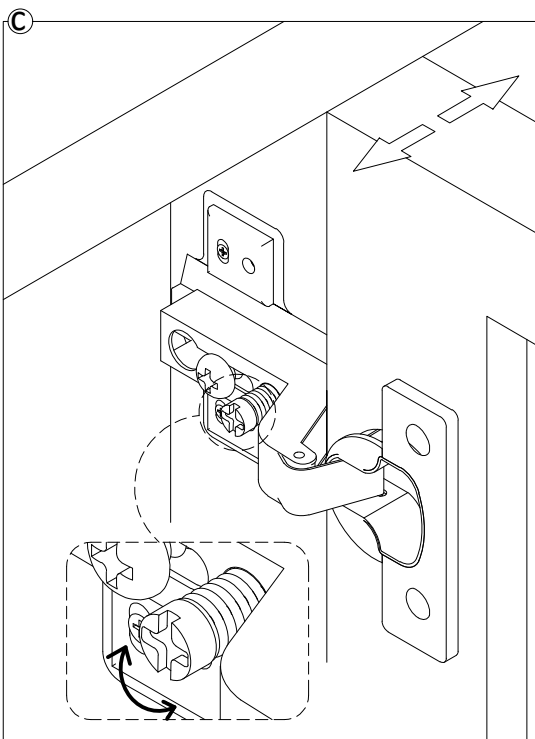

To adjust the door laterally ( such as changing the gap between the two doors), please adjust the screw as shown by turning clockwise or anticlockwise.

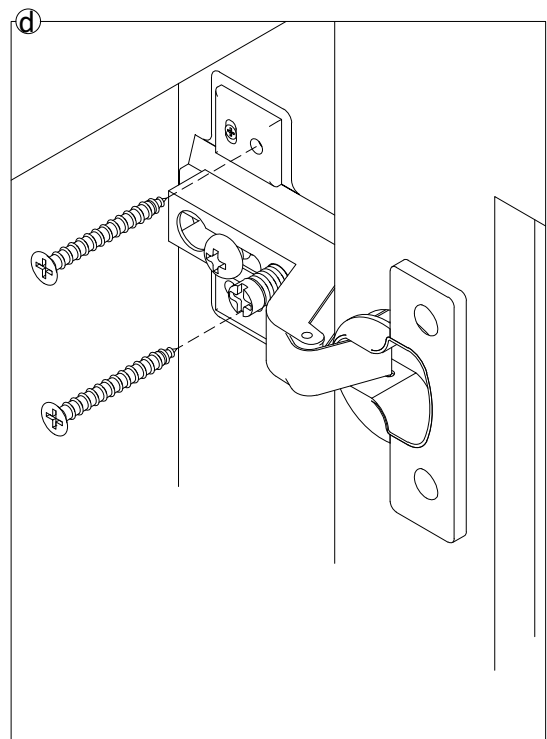

Please fix other screws.

Laying out all the parts and hardware and identifying each part as shown below. It may help you when you assemble the item.

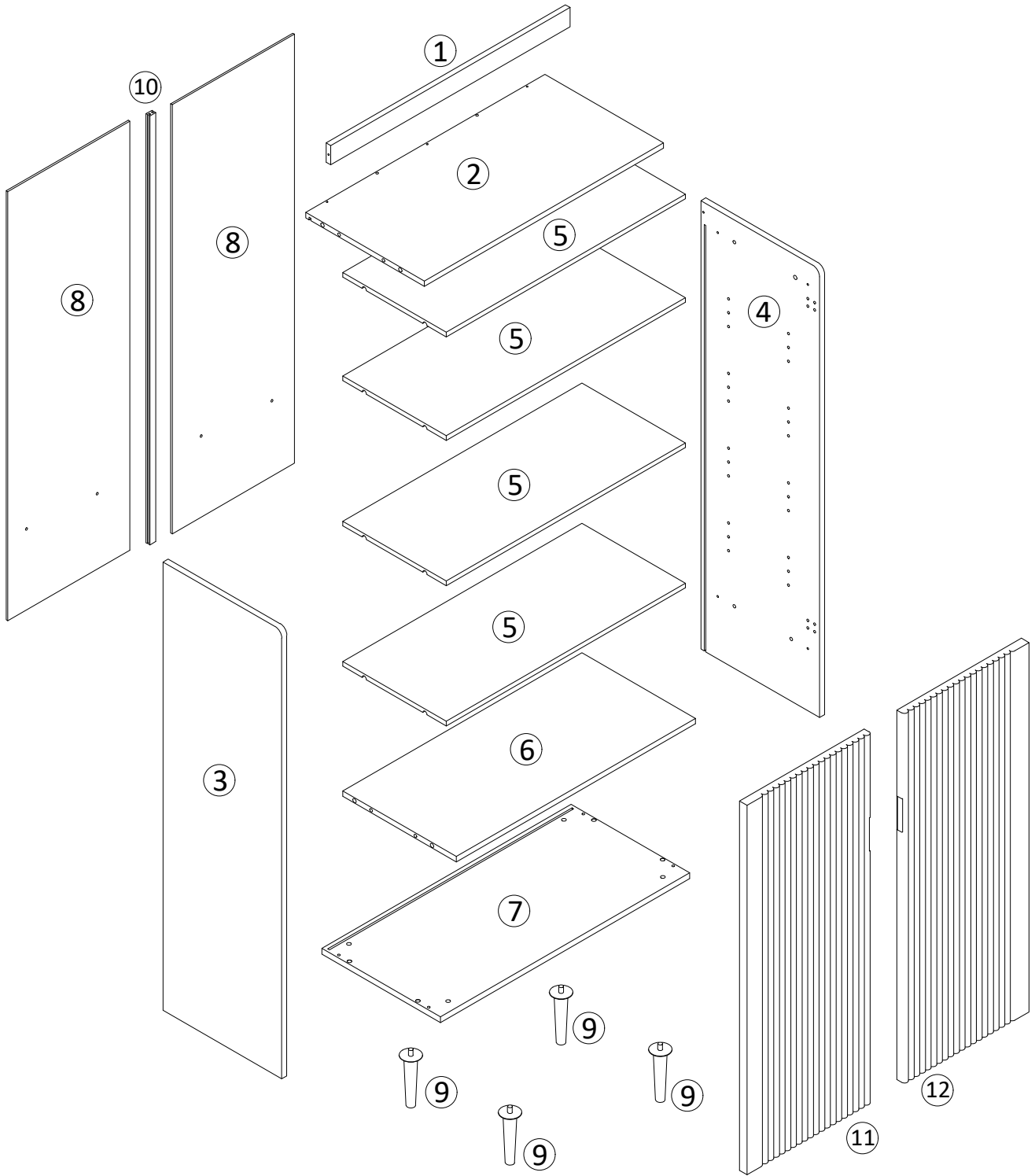

① × 1

② × 1

③ × 1

④ × 1

⑤ × 4

⑥ × 1

⑦ × 1

⑧ × 2

⑨ × 4

⑩ × 1

⑪ × 1

⑫ × 1



1

Turn the screws vertically from slow to fast.

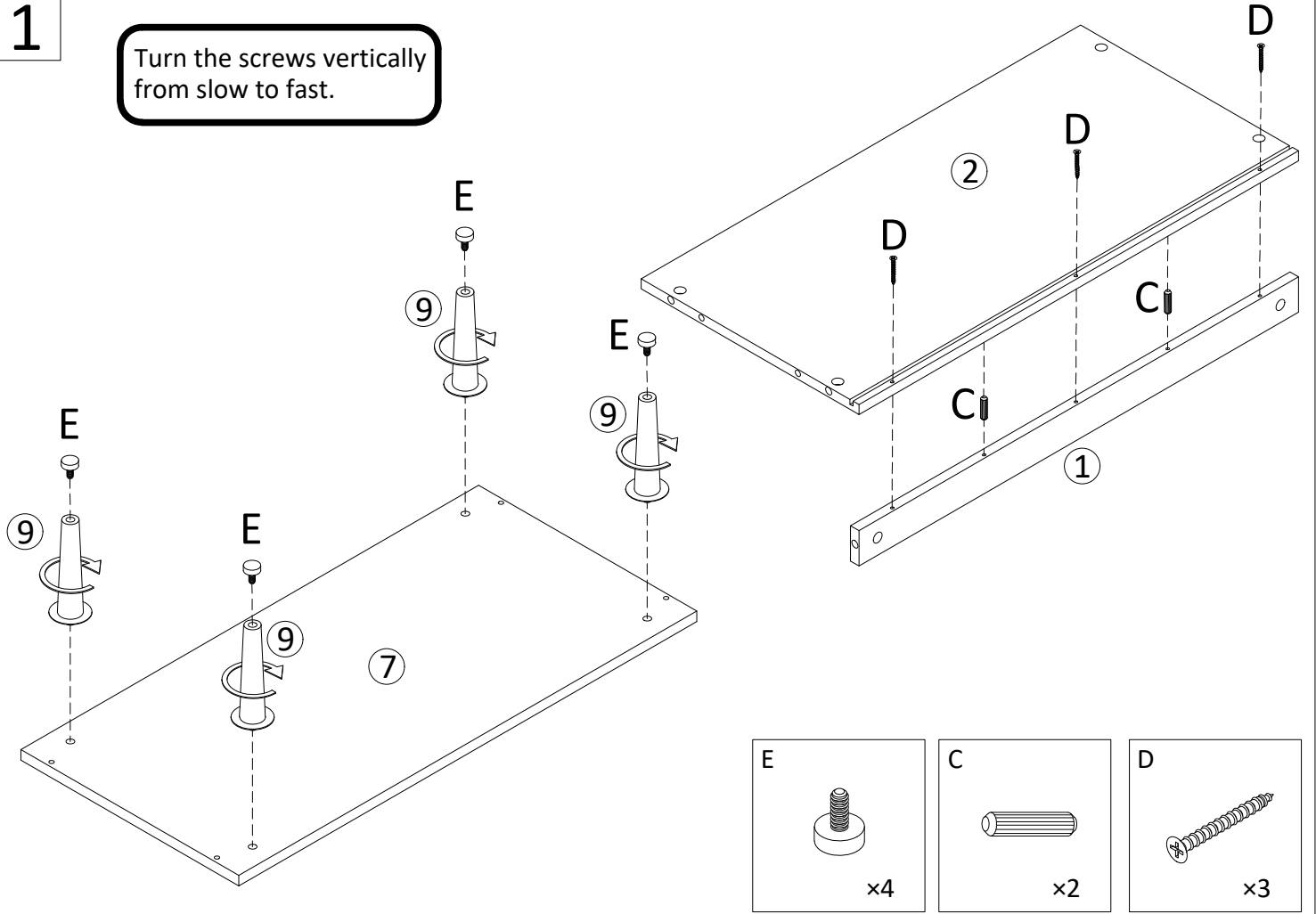

2

Turn the screws vertically from slow to fast.

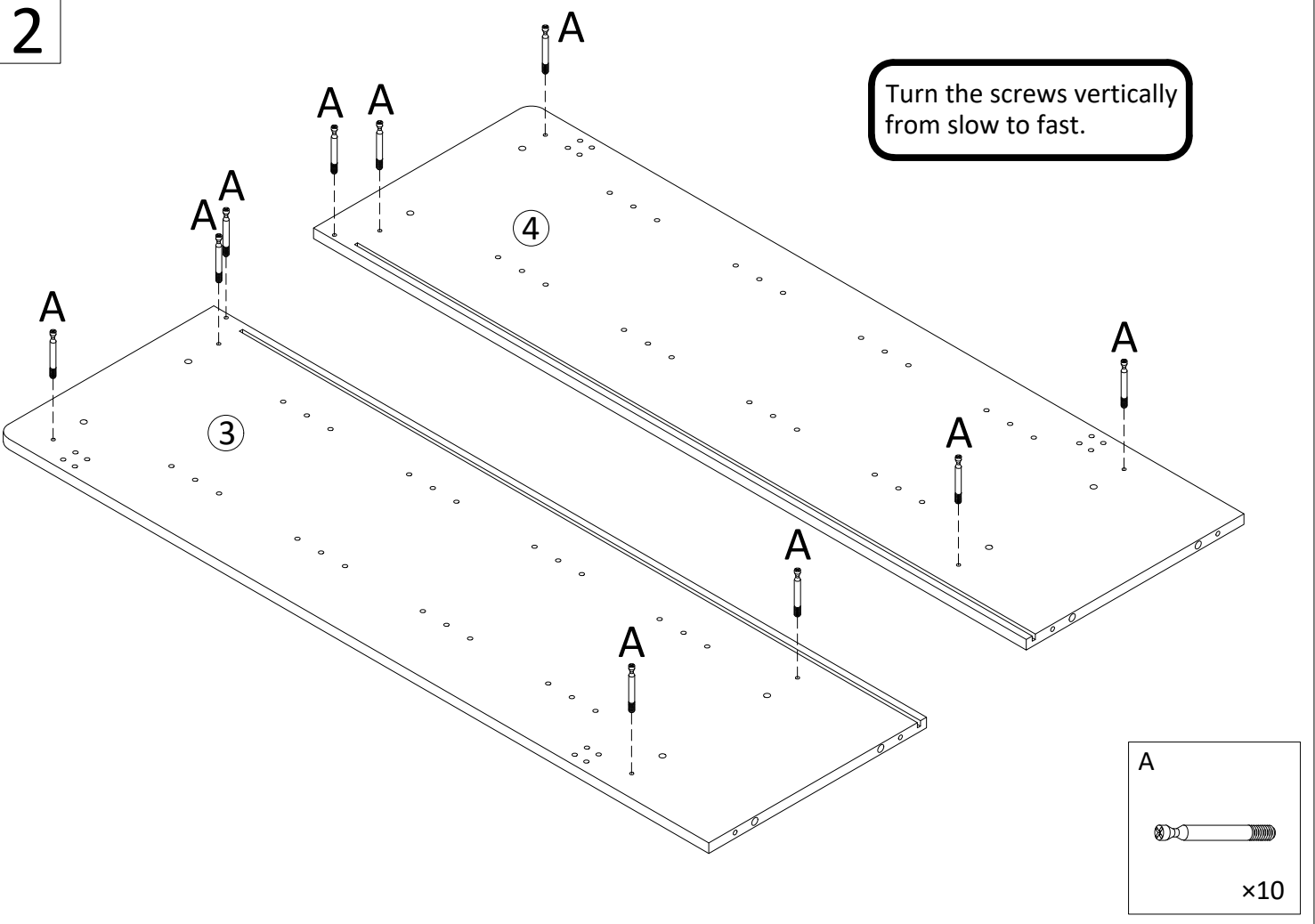

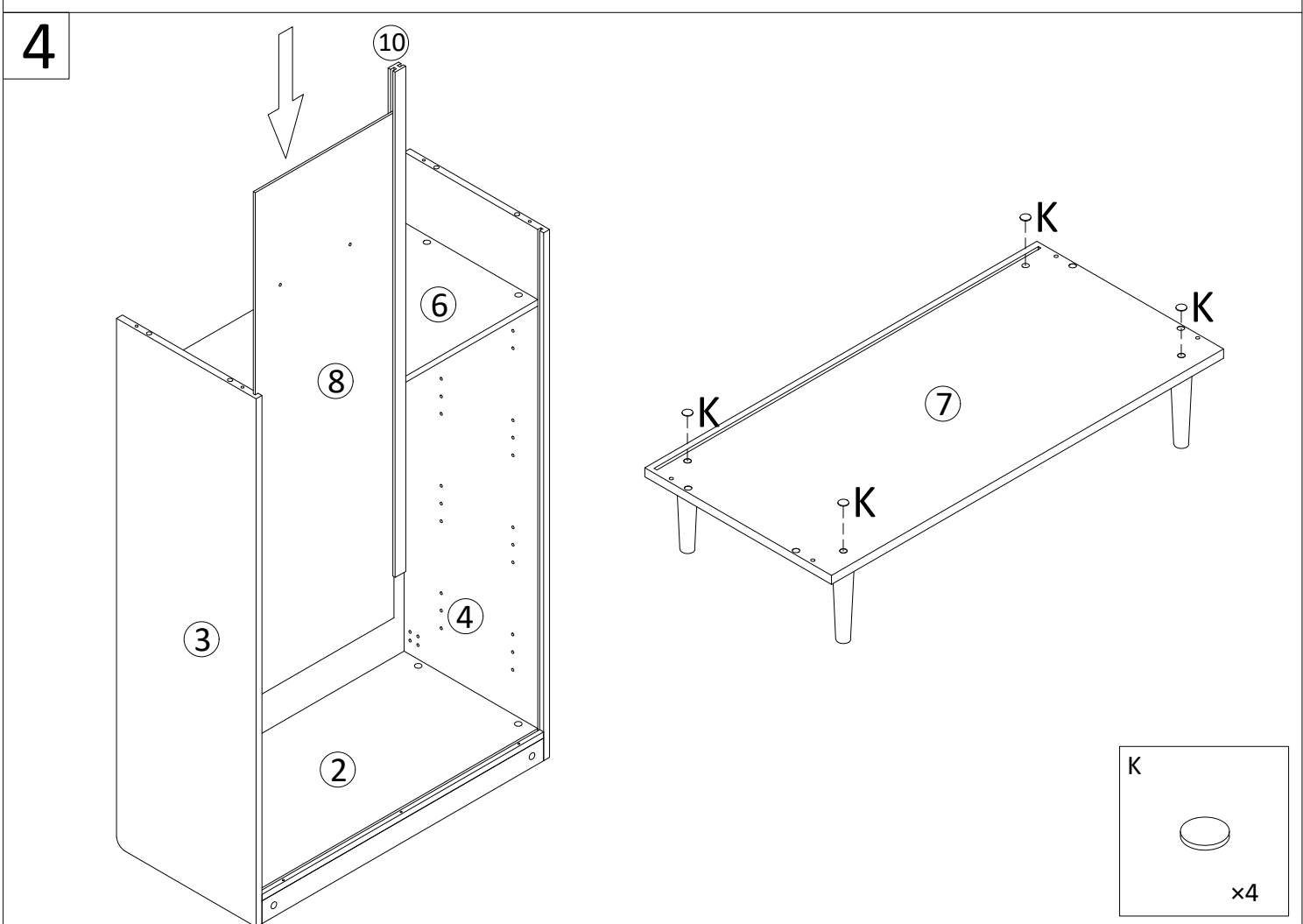
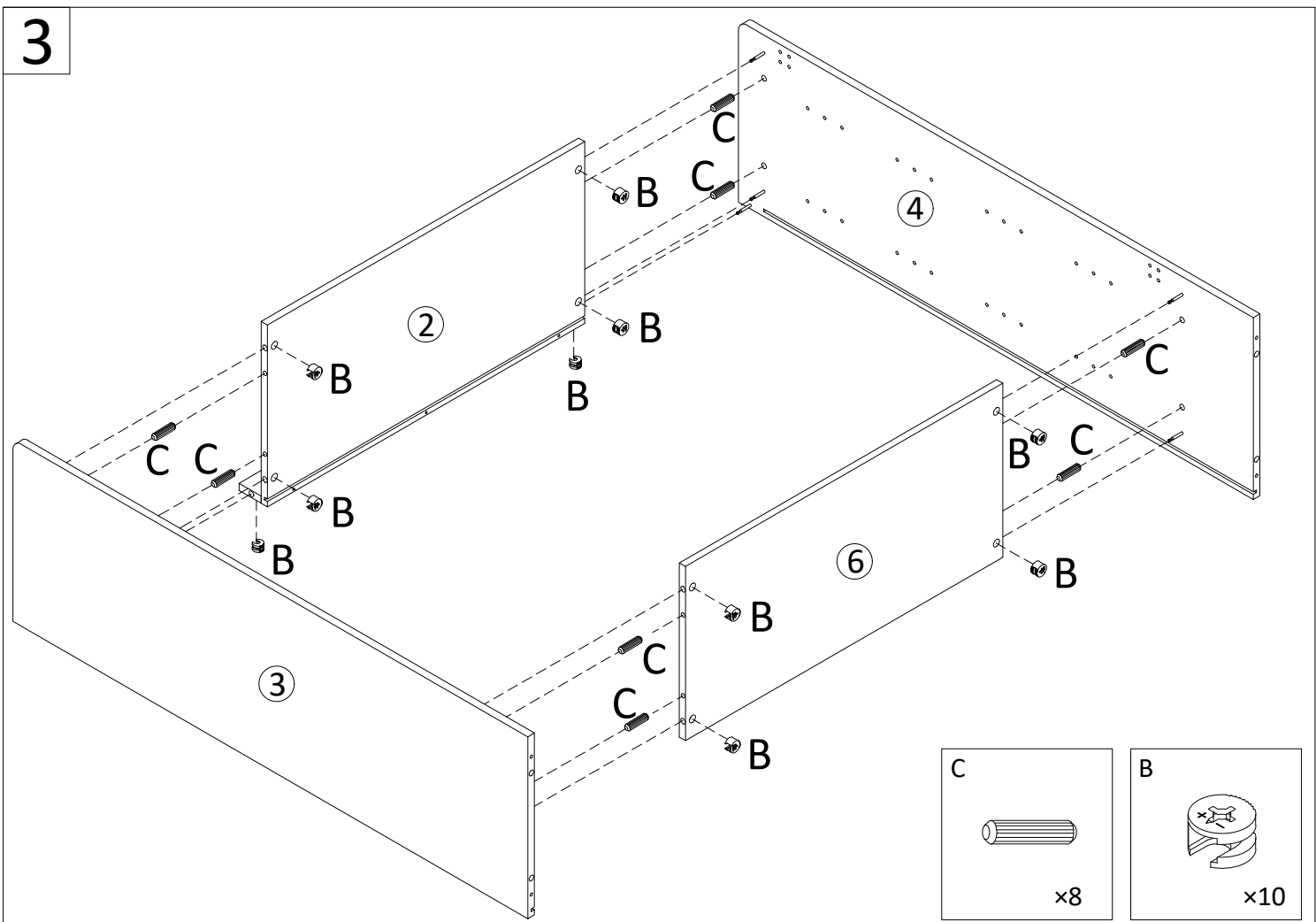

5

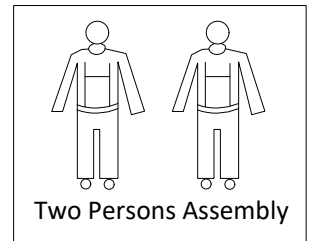
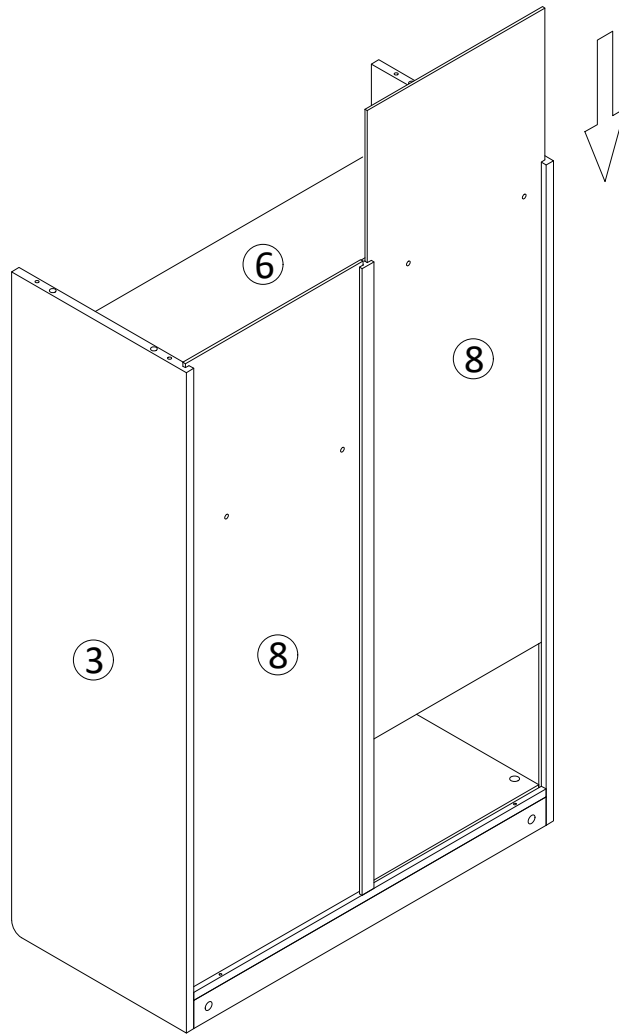

6

Turn the screws vertically from slow to fast.

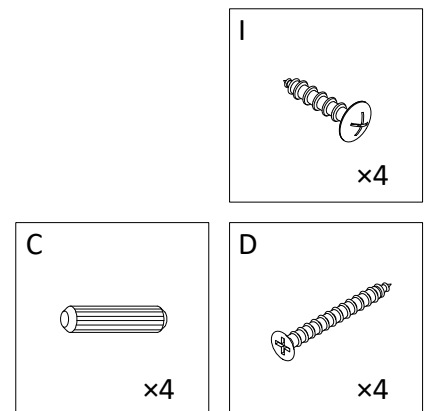
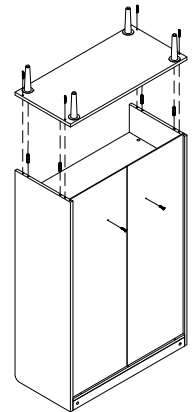
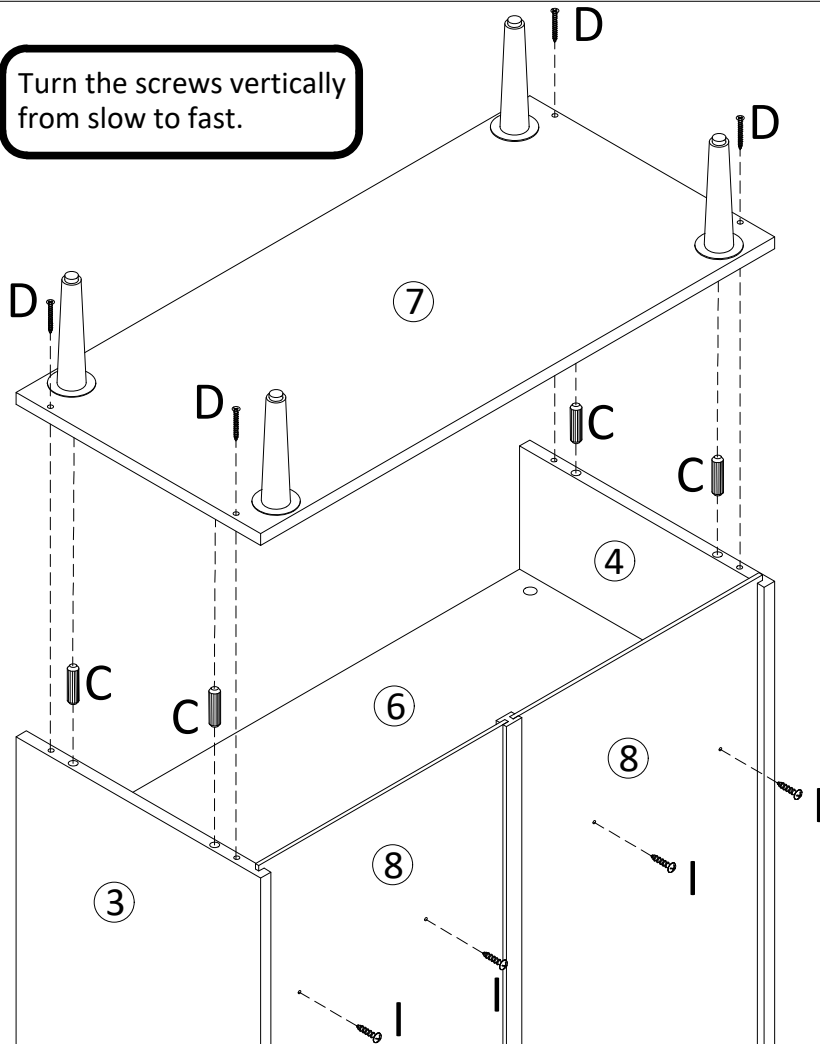

7

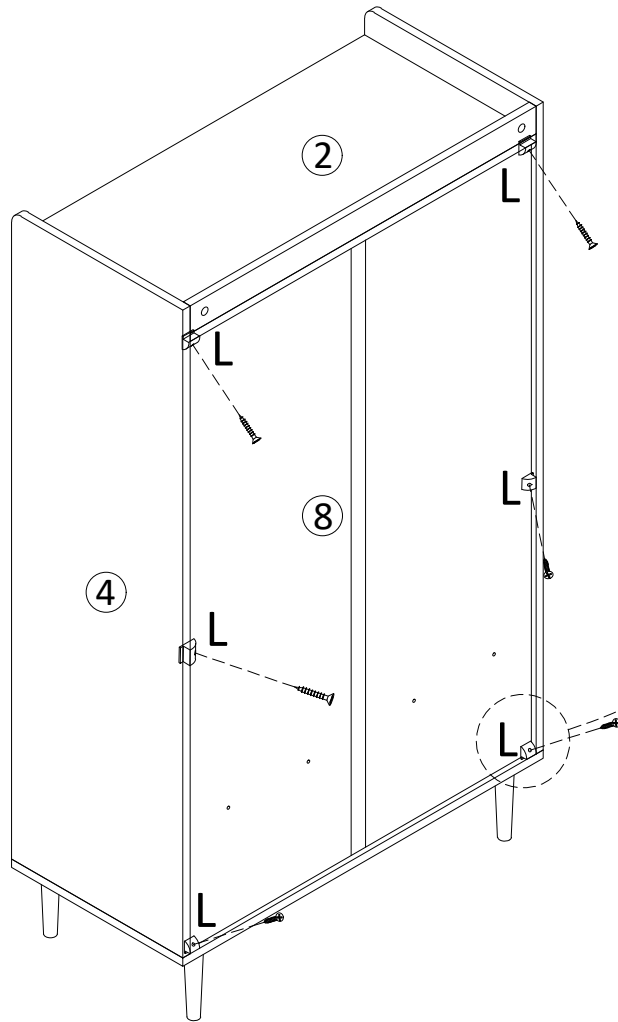

Turn the screws vertically from slow to fast.

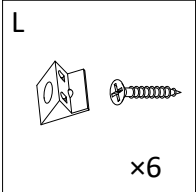

8

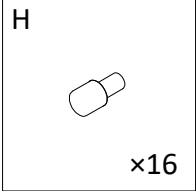
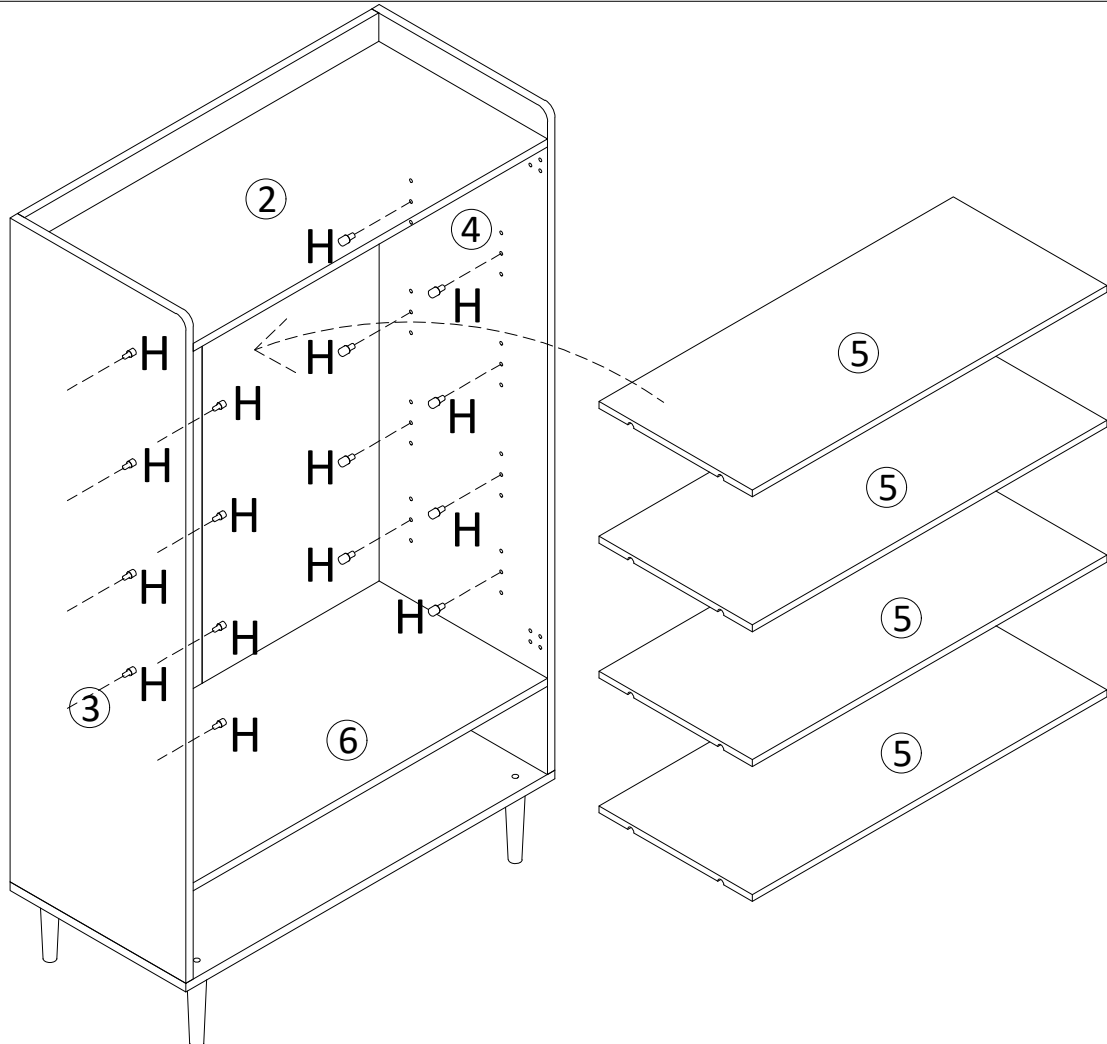

9

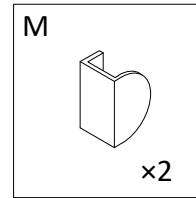
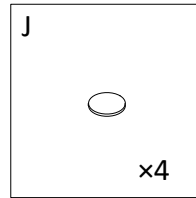
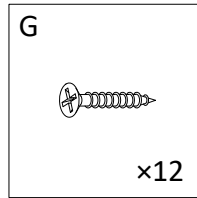
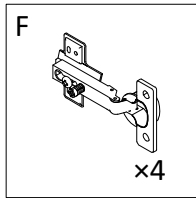
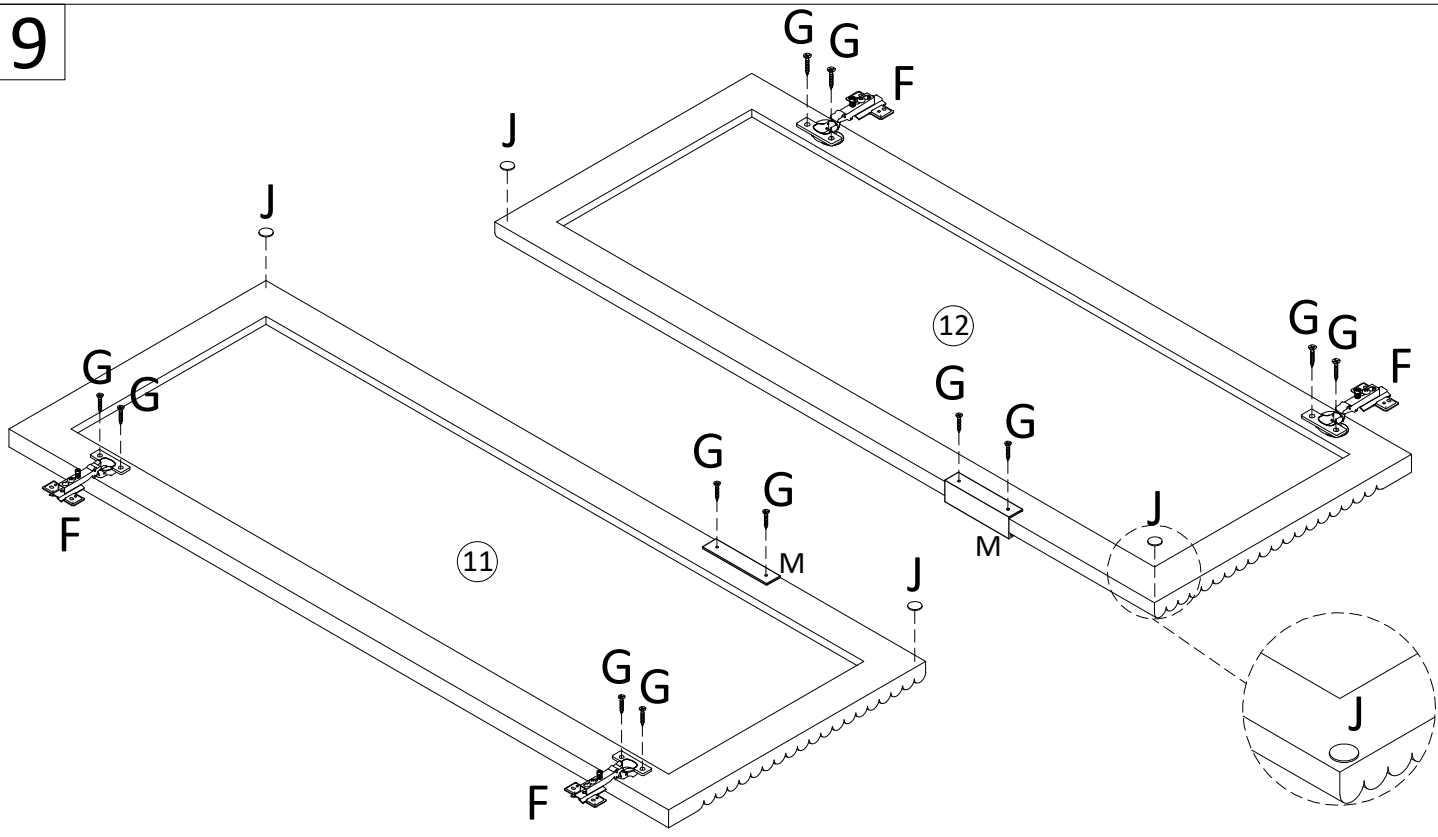

10

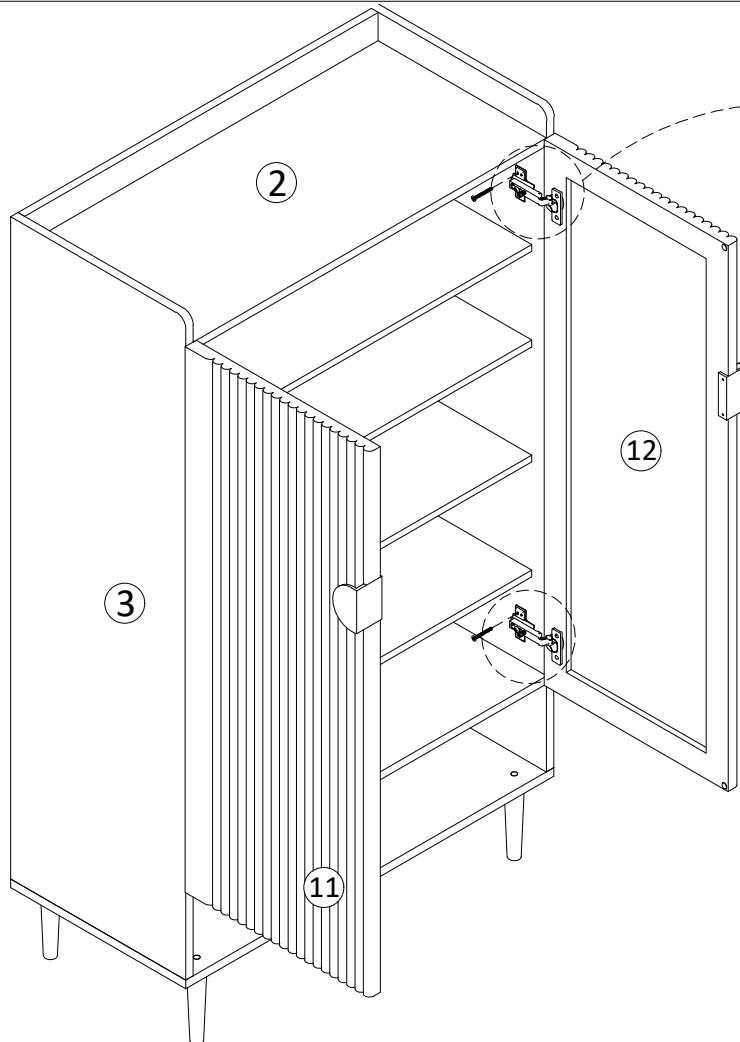

To adjust the door vertically by loosening the screw as shown, and moving up or down as needed.

Turn the screws vertically from slow to fast.

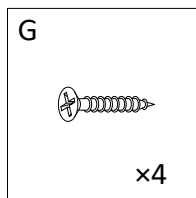

11

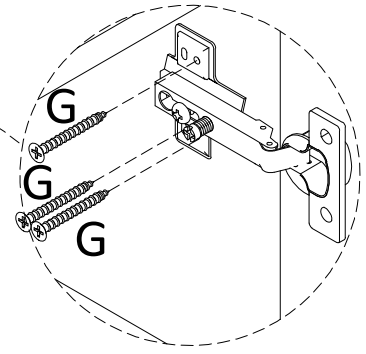
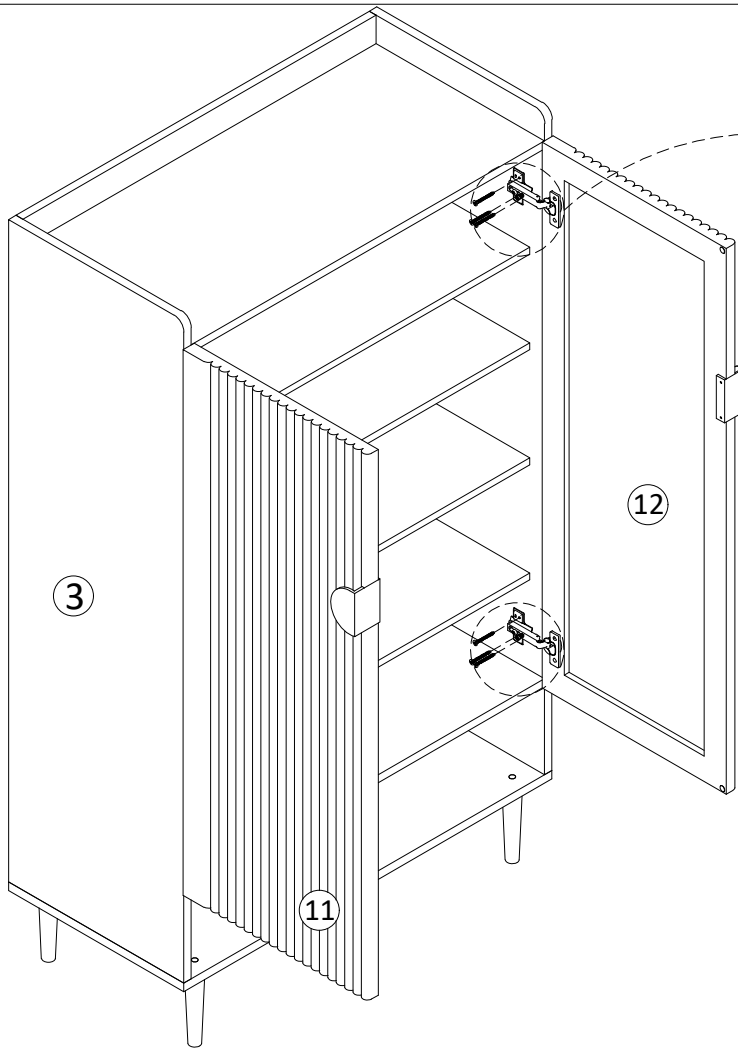

**Note:** To adjust the gap between doors or the gap between doors and side panels, please refer the page 3.

Turn the screws vertically from slow to fast.

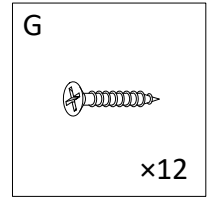

12

