

**ASSEMBLY INSTRUCTIONS &
PARTS IDENTIFICATION**

**FOUR DRAWER SIDEBOARD
TELLURIDE GOLD**

Thank you for purchasing this quality product. Be sure to check all packing material carefully for small parts that may have come loose inside the carton during shipment.

Parts key

No	Code	Qty	Description	No	Code	Qty	Description
1	A	1 pc	End Left Facing Door	9	I	4 sets	Pull w/Screws for Drawer
2	B	1 pc	Center Left Facing Door	10	J	4 pcs	Drawer Stop
3	C	1 pc	Center Right Facing Door	11	K	8 pcs	Drawer Glide
4	D	1 pc	End Right Facing Door	12	L	1 pc	Middle Shelf
5	E	8 pcs	Door Hinge	13	M	2 pcs	Side Shelf
6	F	4 sets	Door Catch	14	N	4 pcs	Floor Glide
7	G	4 sets	Knob w/Screw for Door	15	O	2 pcs	Floor leveler
8	H	4 pcs	Drawer Complete	16	P	1 set	Anti-Tip Kit

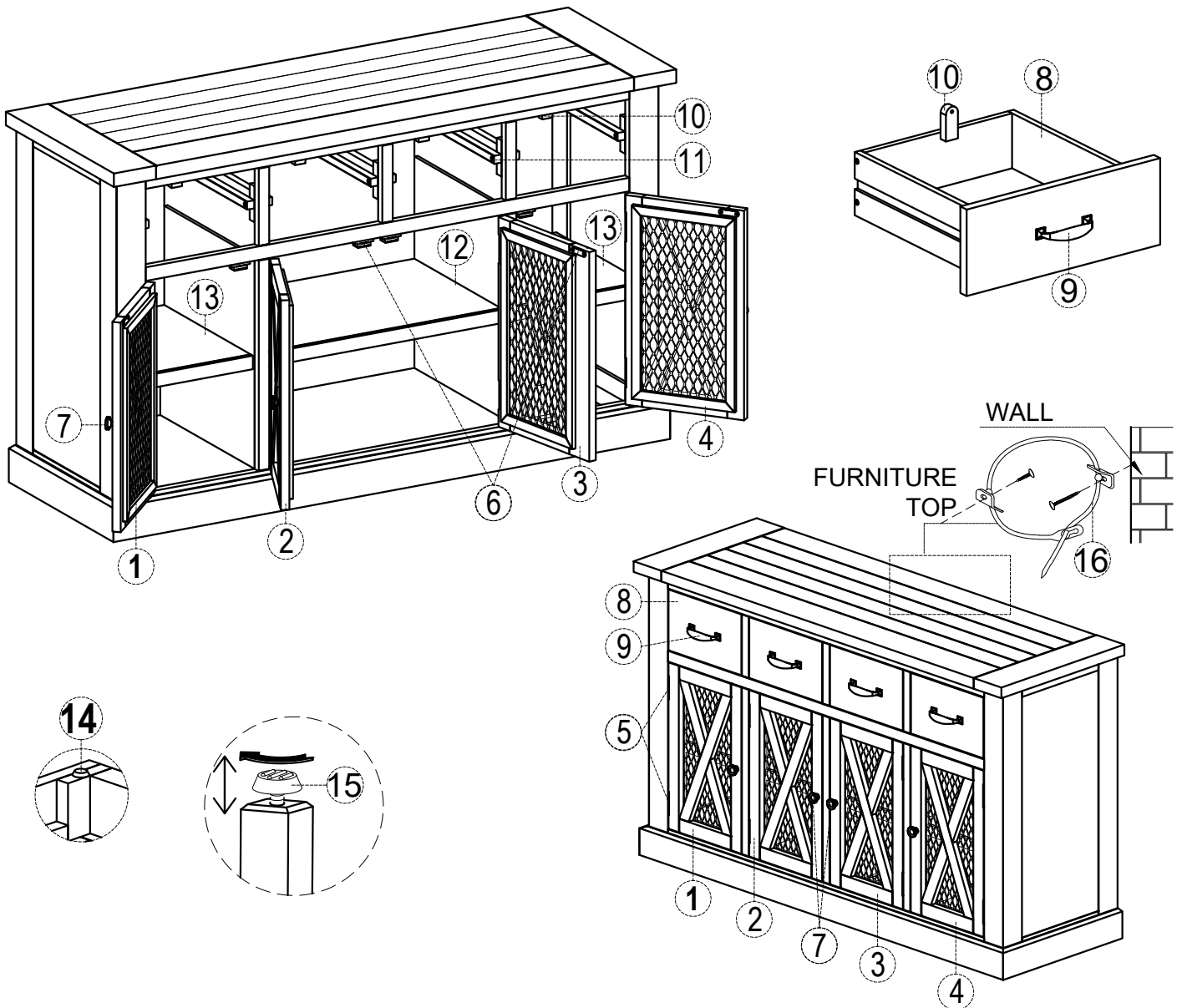





PLEASE NOTE : To help prevent the possibility of tip-over. Install the ANTI- TIP OVER restraint provided.

ASSEMBLY INSTRUCTIONS & PARTS IDENTIFICATION

4 DOOR HUTCH TELLURIDE GOLD

Thank you for purchasing this quality product. Be sure to check all packing material carefully for small parts that may have come loose inside the carton during shipment.

Parts key				Hardware kit			
No	Code	Qty	Description	No	Description		Qty
1	A	2 pcs	Left Facing Door	A	 Bolt	Ø6.3 x 40	12 pcs
2	B	2 pcs	Right Facing Door	B	 Lock washer	Ø8	12 pcs
3	C	12 pcs	Door Hinge	C	 Flat washer	Ø8 x 18	12 pcs
4	D	2 sets	Upper Magnetic Door Catch	D	 Allen Key	K4	1 pc
5	R	2 sets	Lower Magnetic Door Catch				
6	F	4 pcs	Knob w/Screw for door				
7	G	1 set	Spot Light				
8	H	4 pcs	Glass Shelf				
9	I	2 pcs	Long Support Bracket				
10	J	1 pc	Short Support Bracket				
11	K	1 set	Anti-Tip Kit				

PLEASE NOTE :

To help prevent the possibility of tip-over.
Install the ANTI- TIP OVER restraint provided.

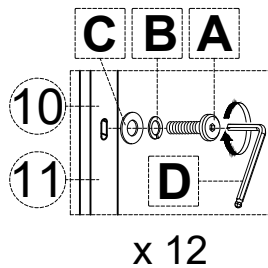
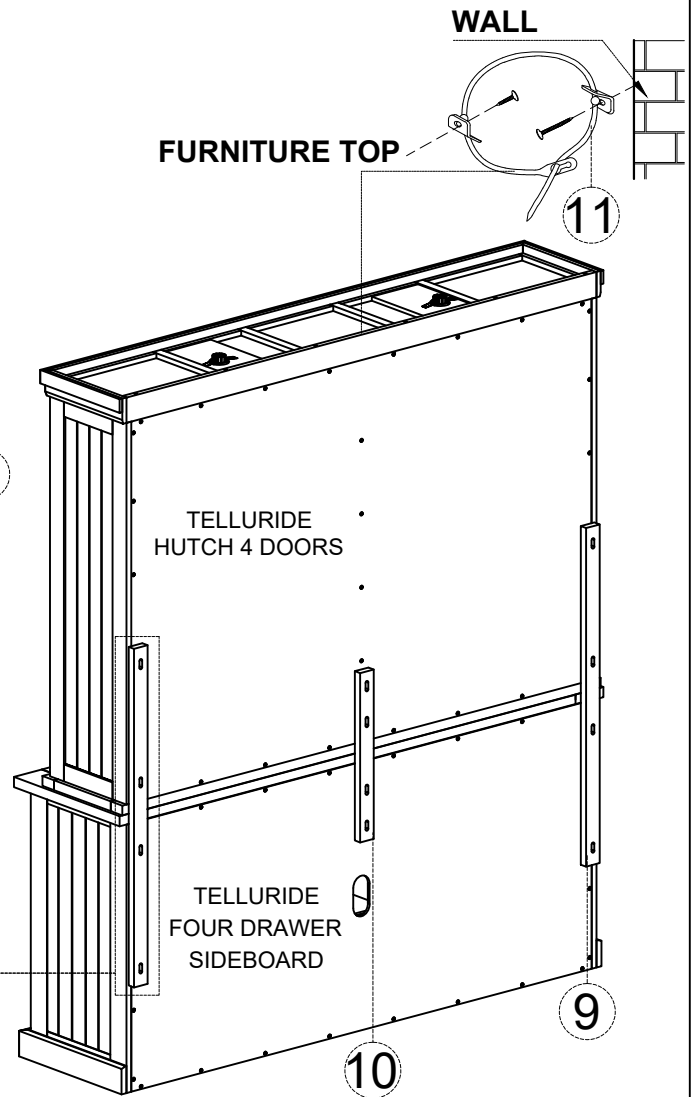
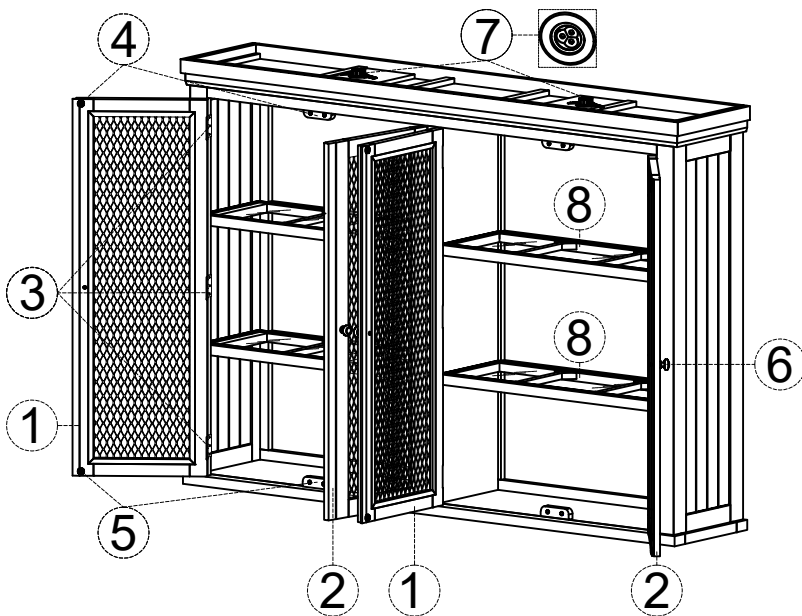

**Attach 2 support bracket (10) and (11)
by using Bolt, Lock washer and Plate washer.
Tighten with Allen Key.**