

# ASSEMBLY INSTRUCTIONS

## 2623

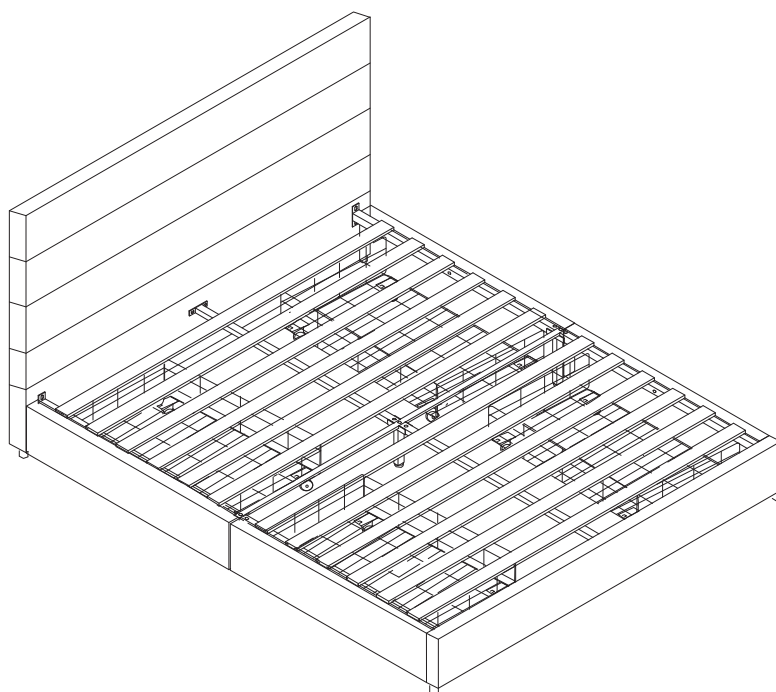
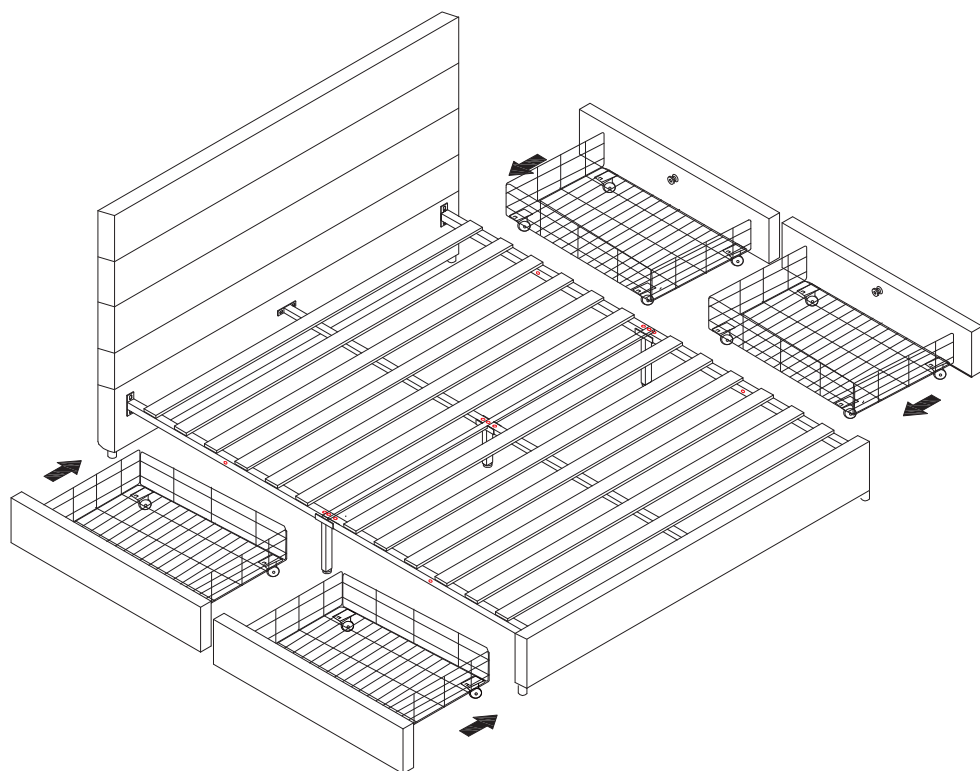

# PARTS AND HARDWARE

① Headboard

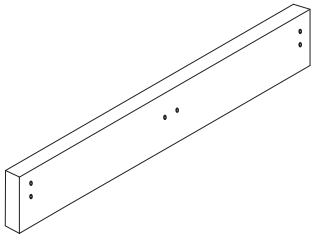

1PC

② Headboard

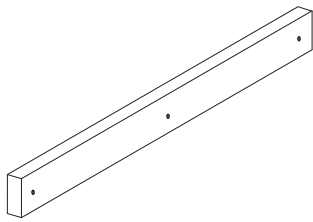

4PCS

③ Footboard

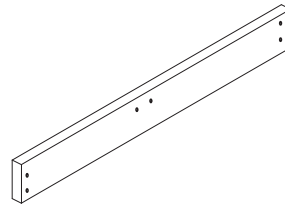

1PC

④ Drawer panel

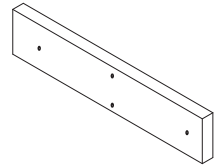

4PCS

⑤ Side Rail Support

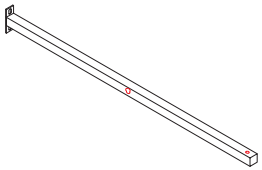

4PCS

⑥ Center support rail

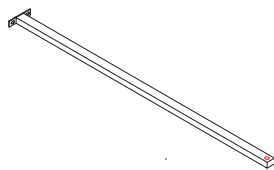

2PCS

⑦ Center cross bar

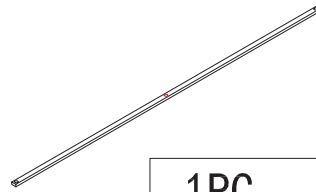

1PC

⑧ Side Rail Feet

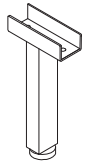

2PCS

⑨ Center Support Leg

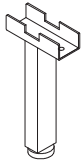

1PC

⑩ Iron fitting behind the headboard

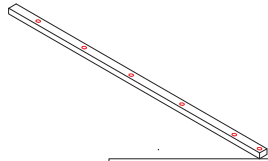

3PCS

⑪ Leg

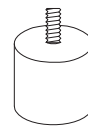

4PCS

⑫ Slat

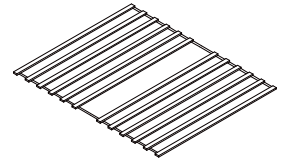

12PCS

⑬ Casters



16PCS

⑭ Fasteners



8 PCS



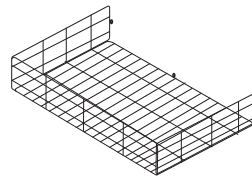



⑮ Drawer wire mesh

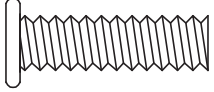

4PCS

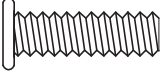

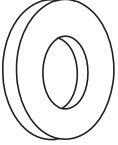

# PARTS AND HARDWARE

## HARDWARE LIST:

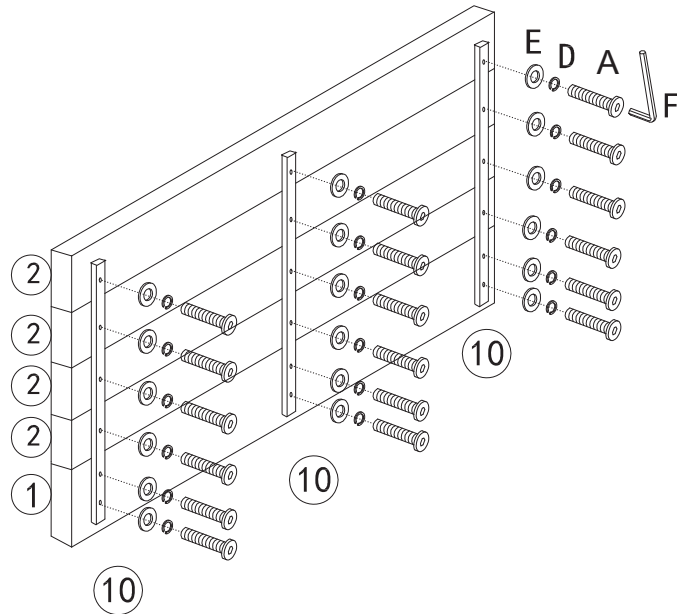
<p><b>A</b></p>  <p>m8*30mm    30PCS</p>	<p><b>B</b></p>  <p>m8*40mm    9PCS</p>	<p><b>C</b></p>  <p>m6*25mm    16PCS</p>	<p><b>D</b></p>  <p>m8    39PCS</p>
<p><b>E</b></p>  <p>m8*19mm    39PCS</p>	<p><b>F</b></p>  <p>m8    1PC</p>	<p><b>G</b></p>  <p>m6    1PC</p>	

## STEP 1







	A x18PCS
	E x18PCS
	D x18PCS
	F x 1PC

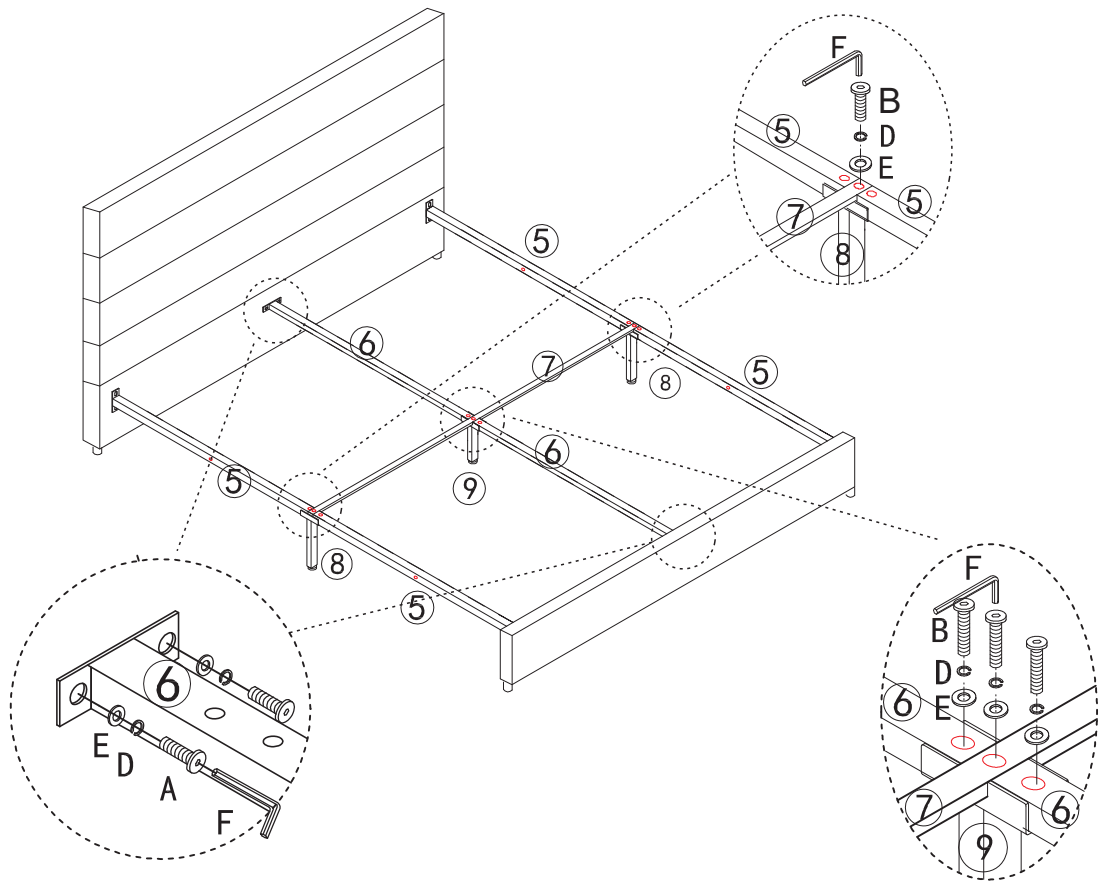

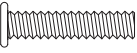
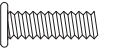
# STEP 4



	A x 4 PCS
	B x 5 PCS
	E x 9 PCS
	D x 9 PCS
	F x 1 PC

# STEP 5

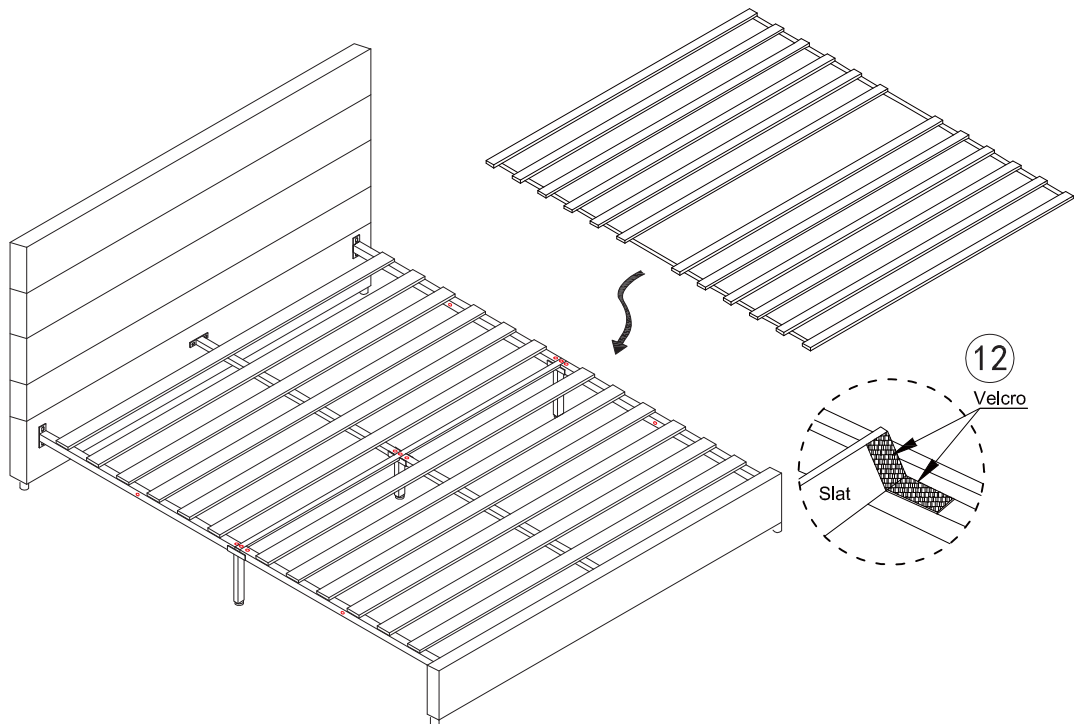

# STEP 6

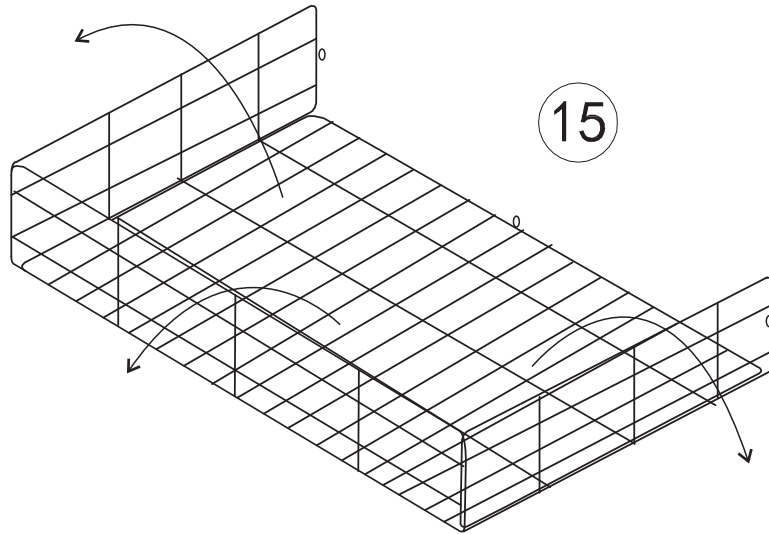

x4

# STEP 7

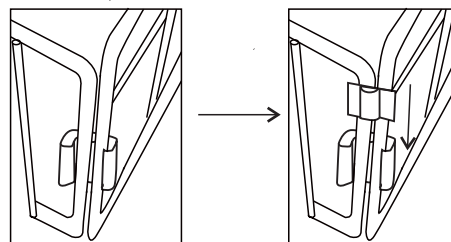
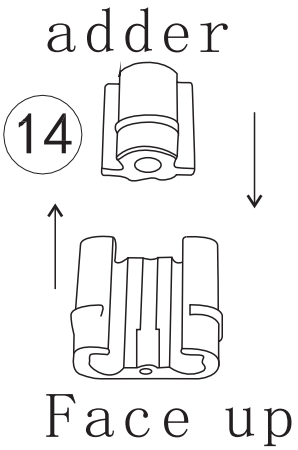
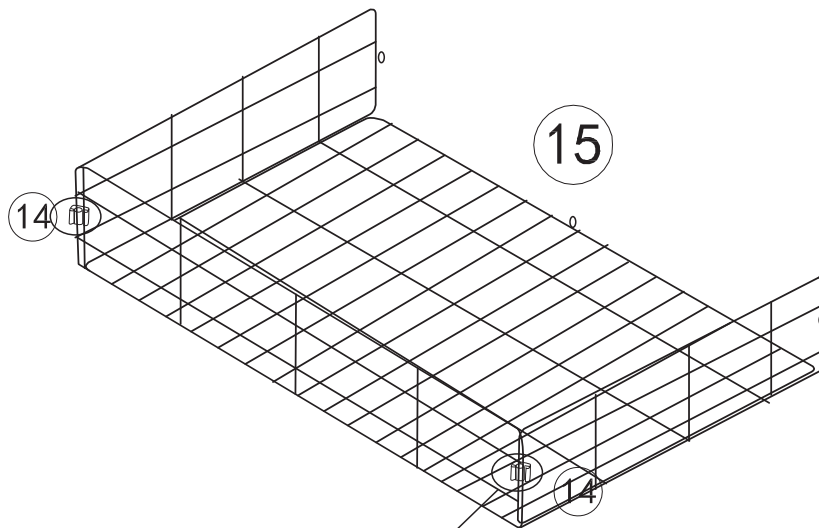

Align and down press

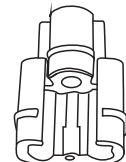

x4



14 x 8 PCS

# STEP 8

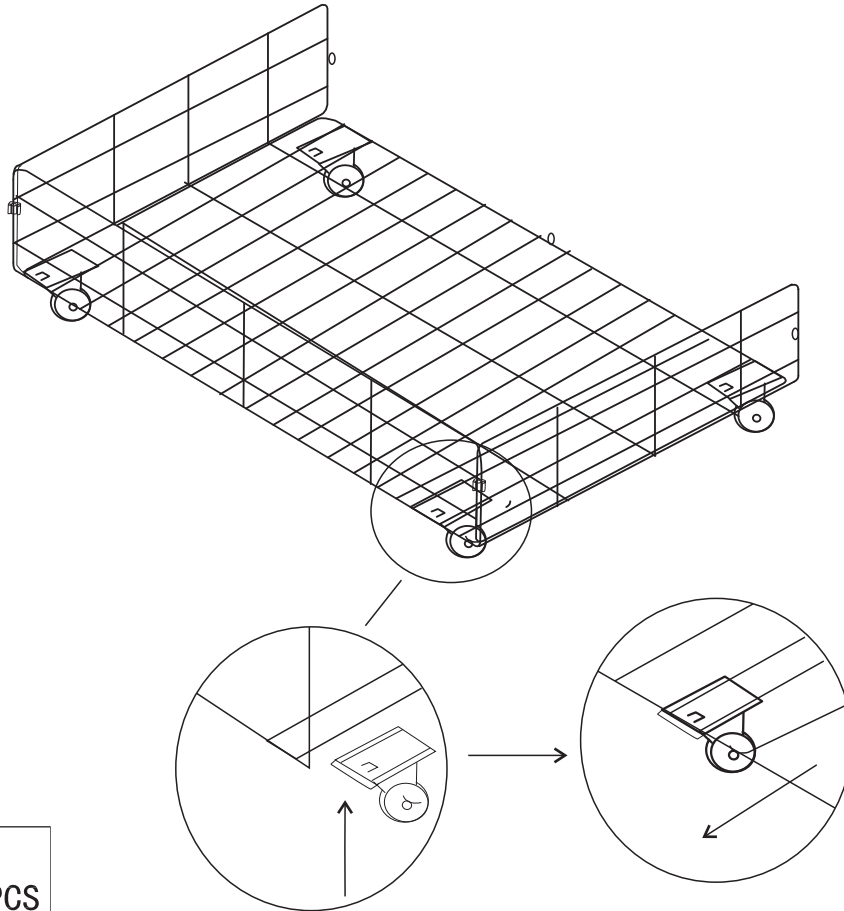

13 x16PCS

x4

# STEP 9

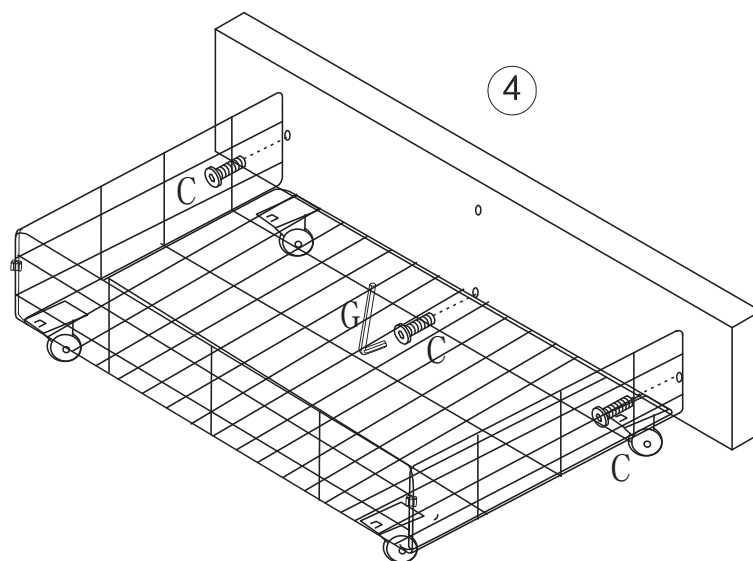

C x12PCS





G x 1PC

x4

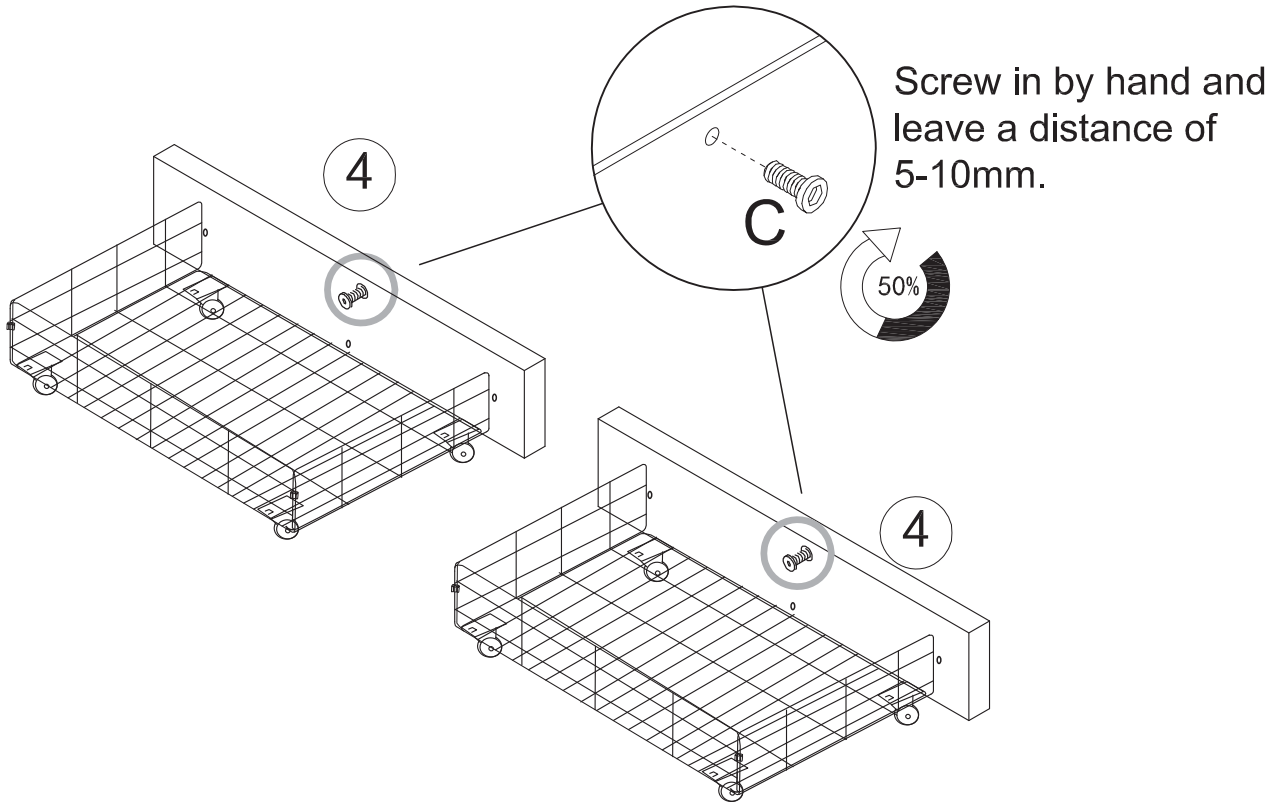
# STEP 10



	C x 4PCS
	G x 1PC

x4

# STEP 11

Drawer panel screw hang into side cross beam hole.

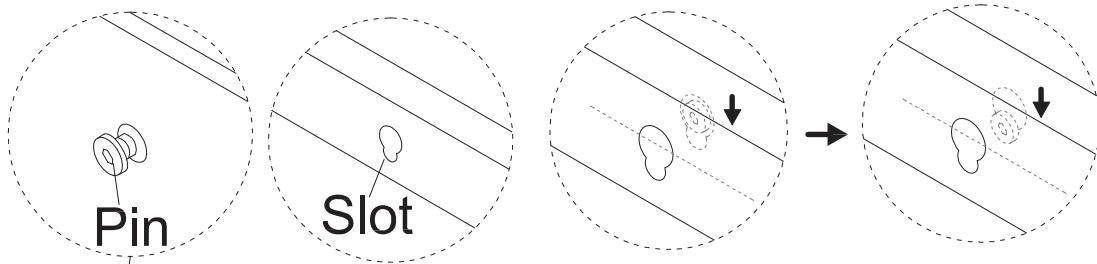

There is a screw head on the drawer board. Hang them in the hole as shown in the figure.

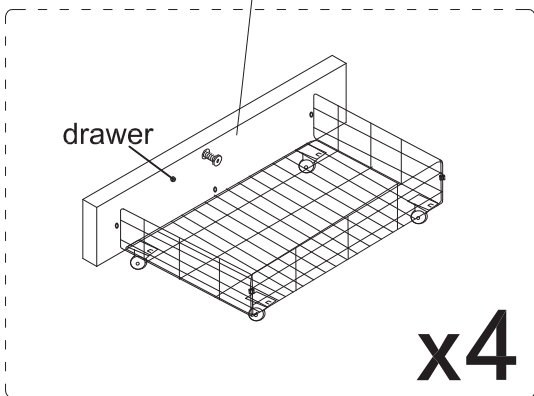

# STEP 12

