

Assembly Instructions

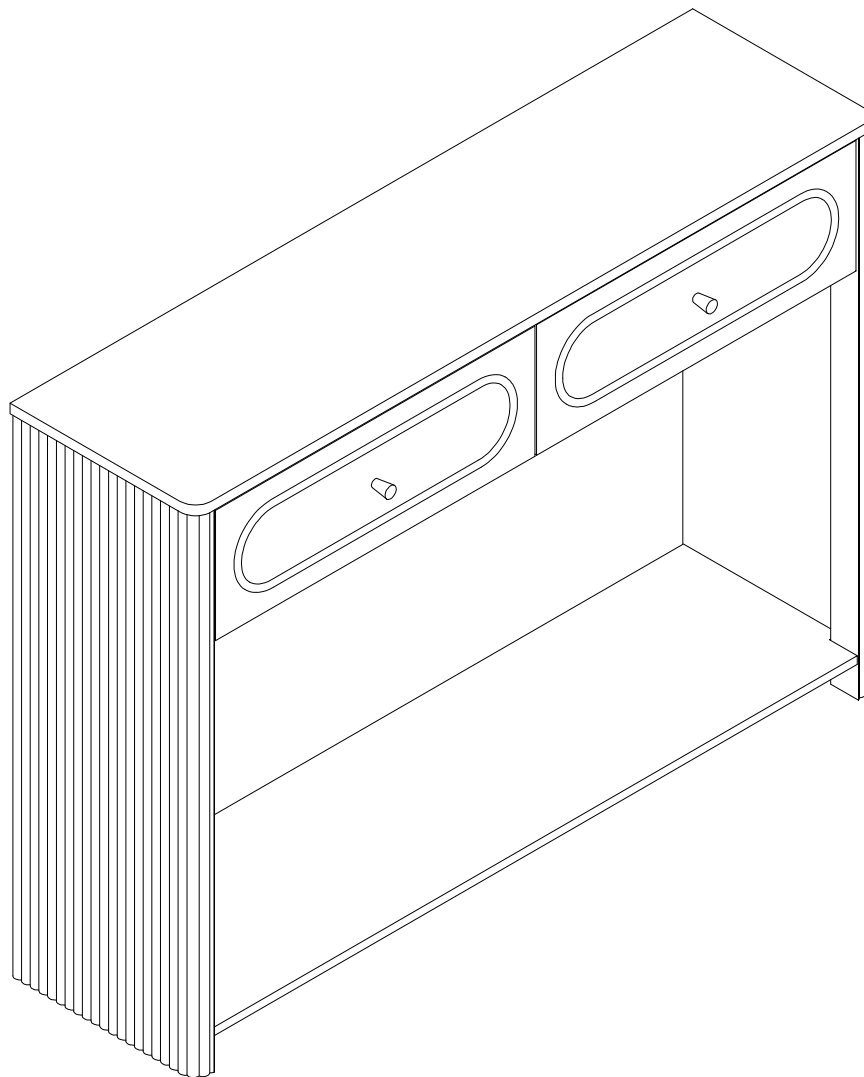

Before Assembly

Tips Before Your Start:

- Remove all wrapping material, including staples & packing straps before you start to assemble.
- DO NOT tighten all screws and bolts until the assembly is completely assembled.
- Keep all hardware parts out of reach of children.

QUICKFIT

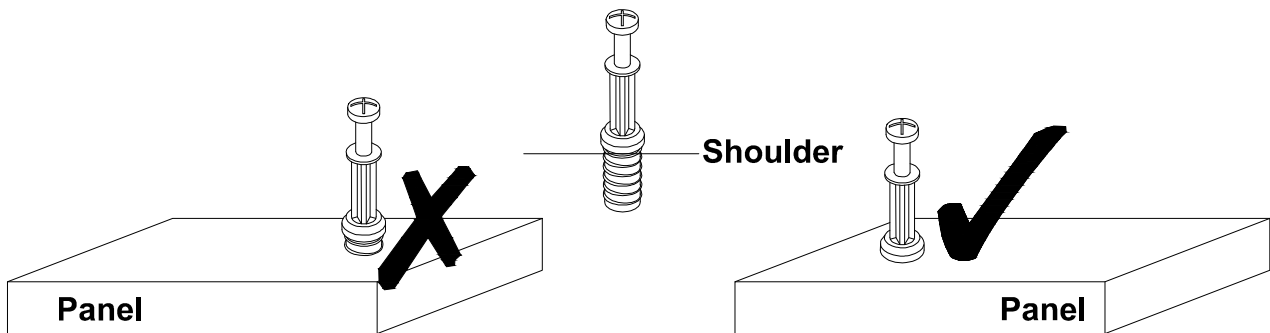

Tighten quickfit until shoulder is flush with panel. Do not overtighten or undertighten.

CAM LOCK

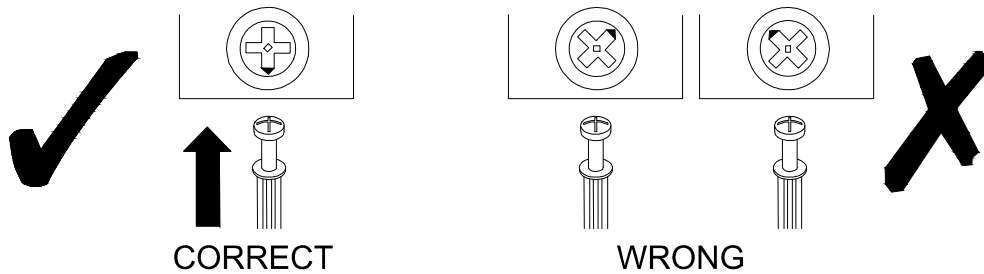

When fitting a cam lock, ensure the starting position is correct before inserting the connecting QUI CKFIT

Quickfit head should be in the centre of the cam lock when the two panels are joined.

Cam lock should be inserted before quickfit.

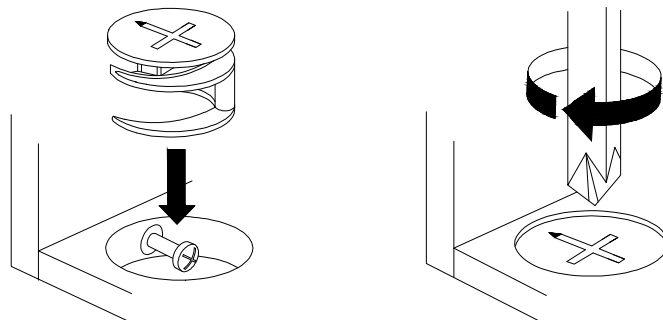

Turn cam lock clockwise to tighten.

Before Assembly

Tips Before Your Start

How to separate the drawer slider:

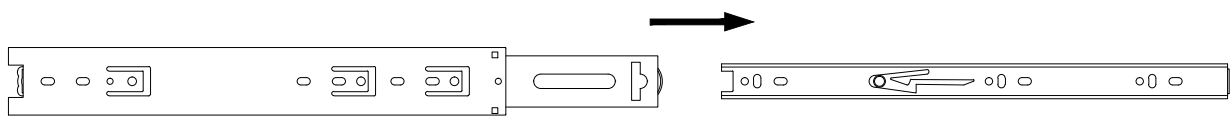
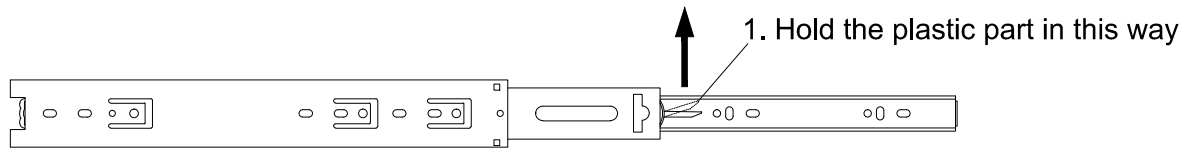

2. Pull out the inner slider for drawer box fixing

Drawer Front Alignment

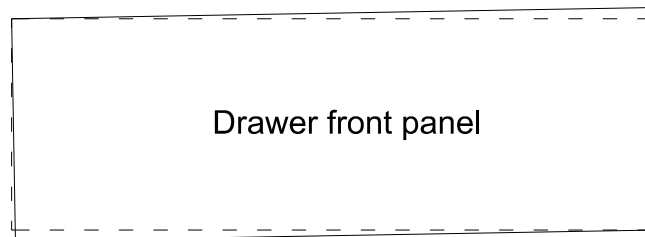



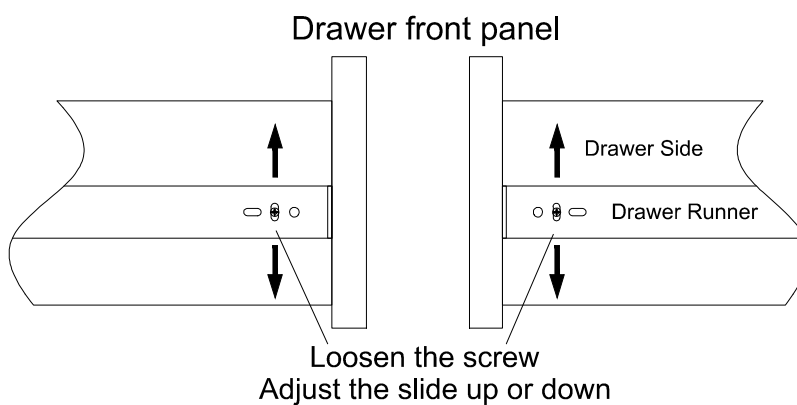







If the drawer front panel is NOT level after being assembled, then...

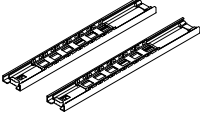

Loosen the screws on the left and right hand side, then adjust the drawer slide up or down, until the drawer fronts are even/level, then tighten the screws.

Part List

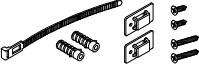
<p>No. A Quantity:47 Pcs Cam Lock Dowel 8*28mm</p> 	<p>No. B Quantity:47 Pcs Cam φ15</p> 	<p>No. C Quantity:47 Pcs Sticker Ø20</p> 	<p>No. D Quantity:15 Pcs Dowel 6*30mm</p> 
<p>No. E Quantity:2 Sets Drawer Slider 10"</p> 	<p>No. F Quantity:16 Pcs Screw M3.5*12mm</p> 	<p>No. G Quantity:8 Pcs Screw M4*30mm</p> 	<p>No. H Quantity:2 Pcs Screw M4*16mm</p> 
<p>No. I Quantity:4 Pcs Foot Pad Ø12*5</p> 	<p>No. J Quantity:2 Pcs Handle Ø20*23mm</p> 	<p>No. K Quantity:1 Sets Anti-falling Parts</p> 	

Product structure

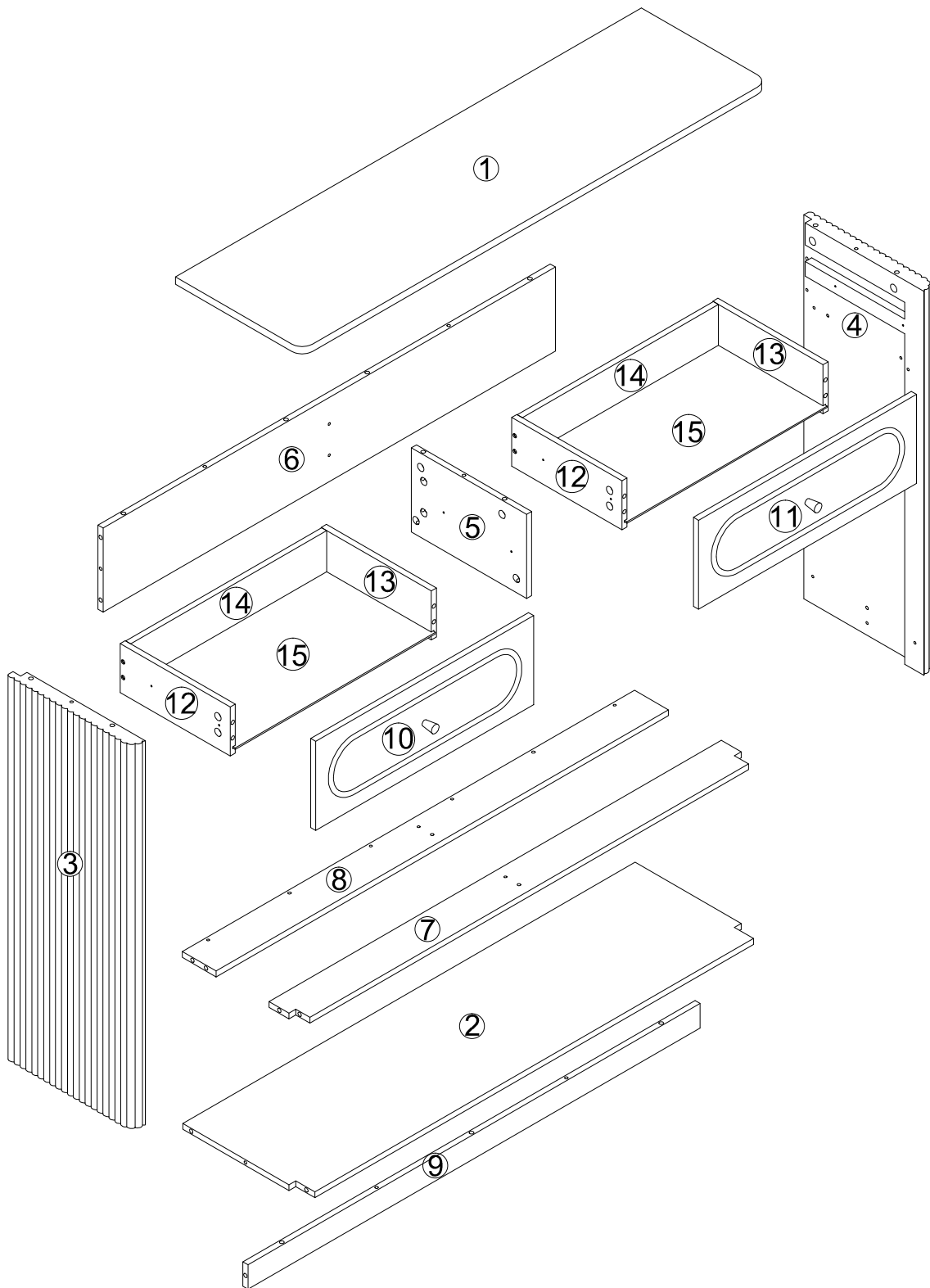

STEP 1

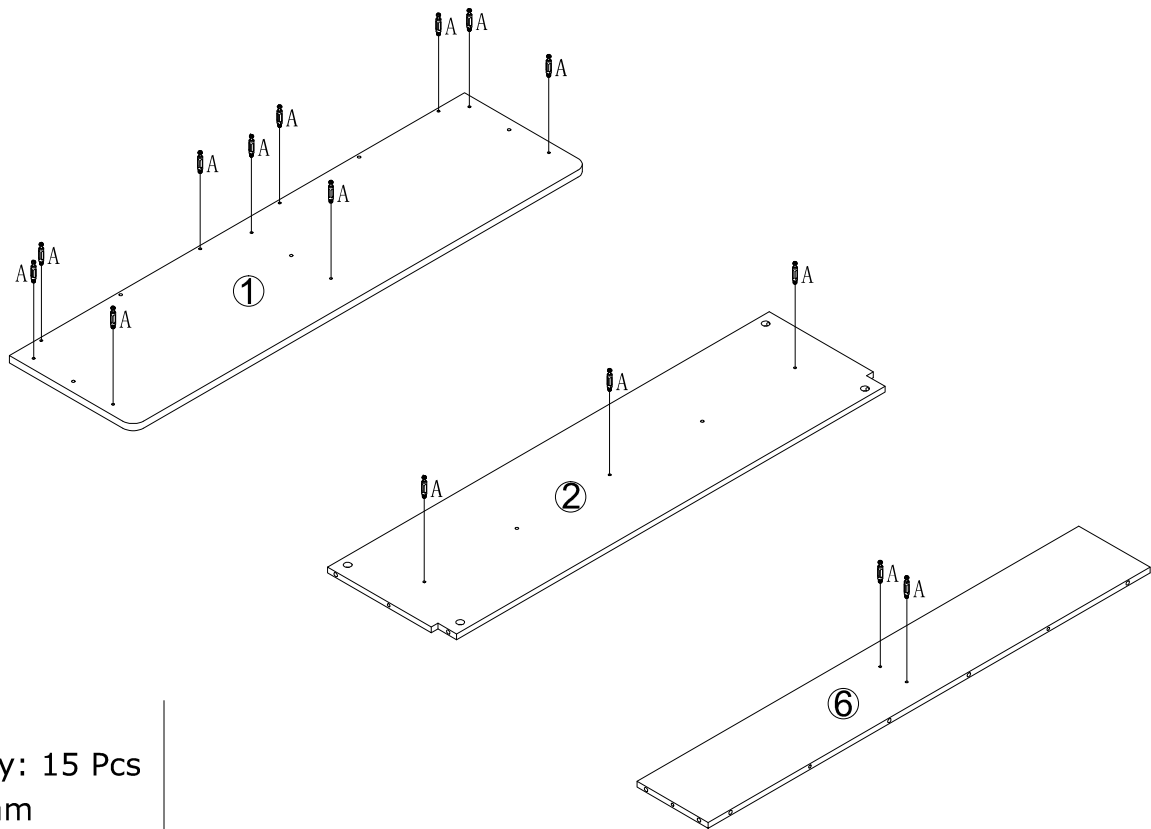

No. A
Quantity: 15 Pcs
8*28 mm



STEP 2

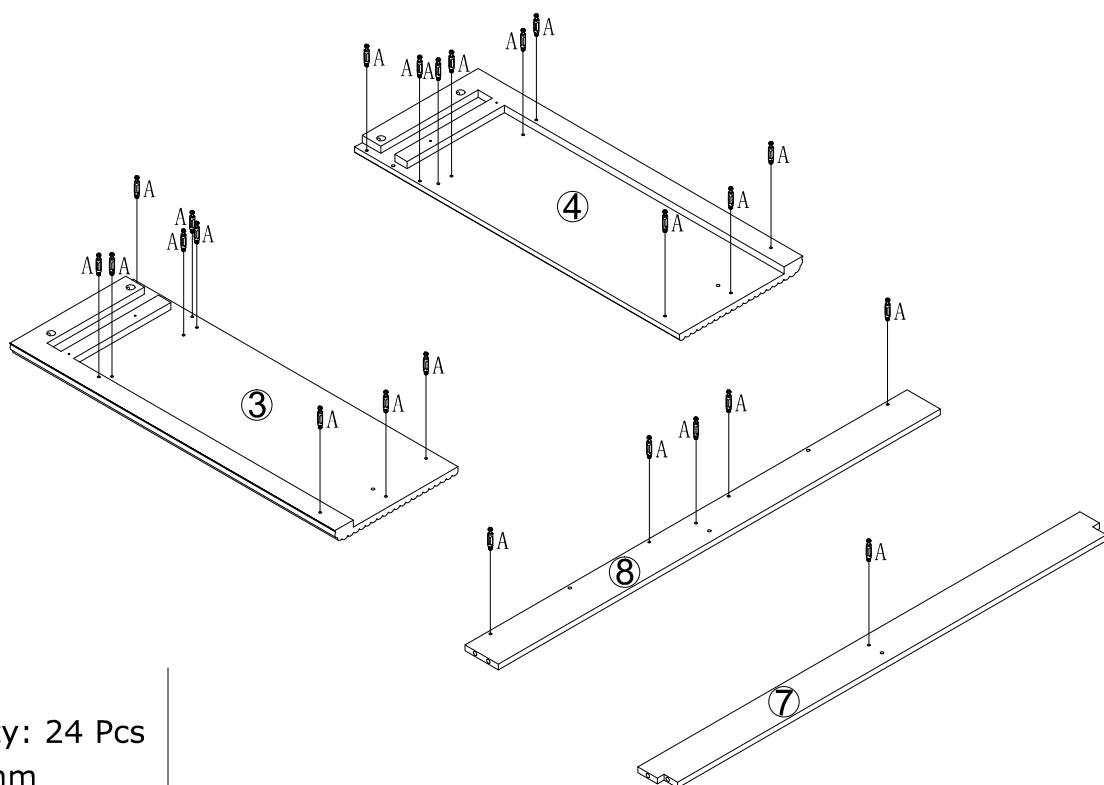

No. A
Quantity: 24 Pcs
8*28 mm



STEP 3



The first screw hole should correspond with the board location hole

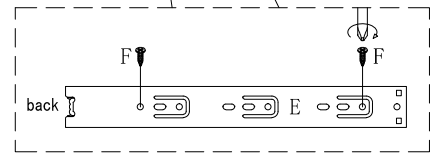
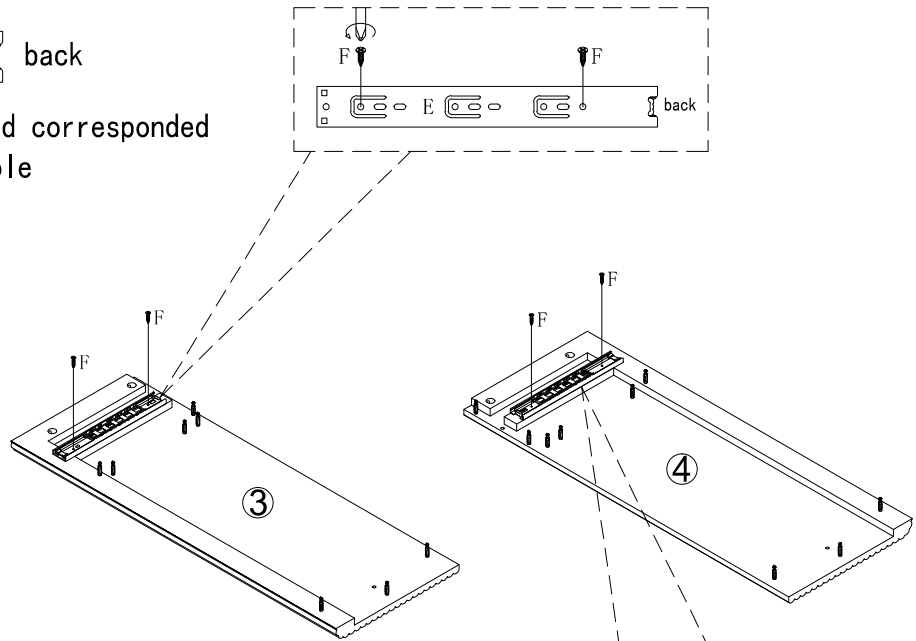

No. E
Quantity: 1 Sets
10"

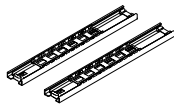

No. F
Quantity: 4 Pcs
M3.5*12mm



STEP 4



The first screw hole should correspond with the board location hole

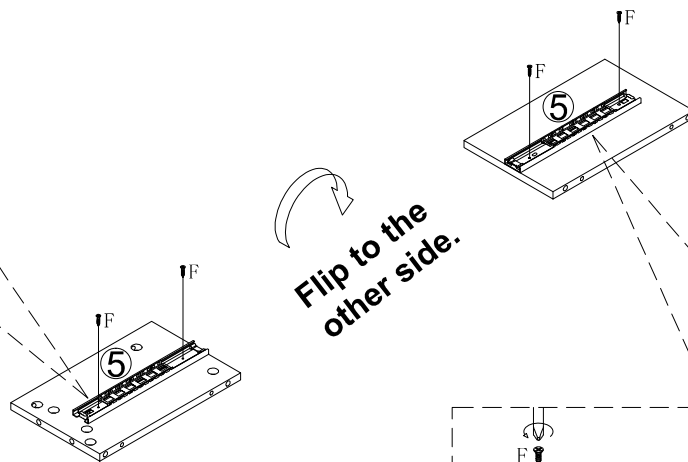
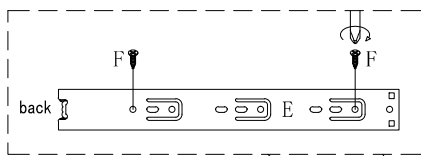

Flip to the other side.

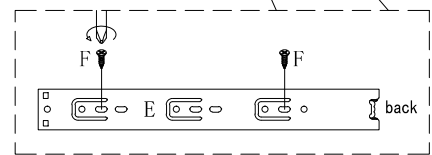

No. E
Quantity: 1 Sets
10"

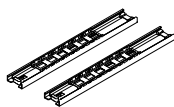

No. F
Quantity: 4 Pcs
M3.5*12mm



STEP 5

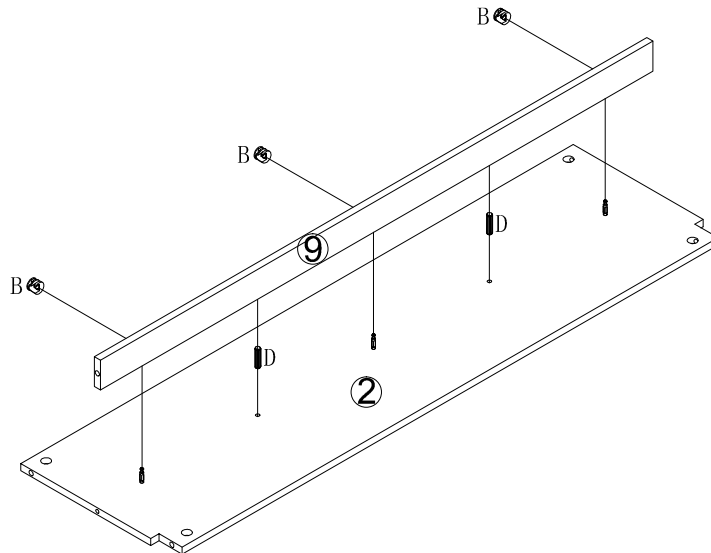

No. B
Quantity: 3 Pcs
Ø15



No. D
Quantity: 2 Pcs
6*30mm

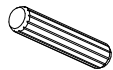

STEP 6

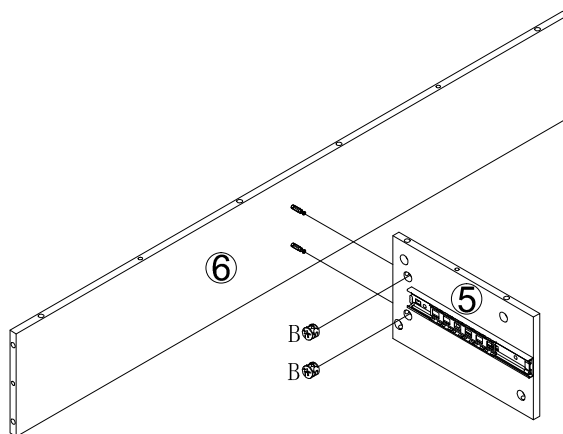

No. B
Quantity: 2 Pcs
Ø15



STEP 7

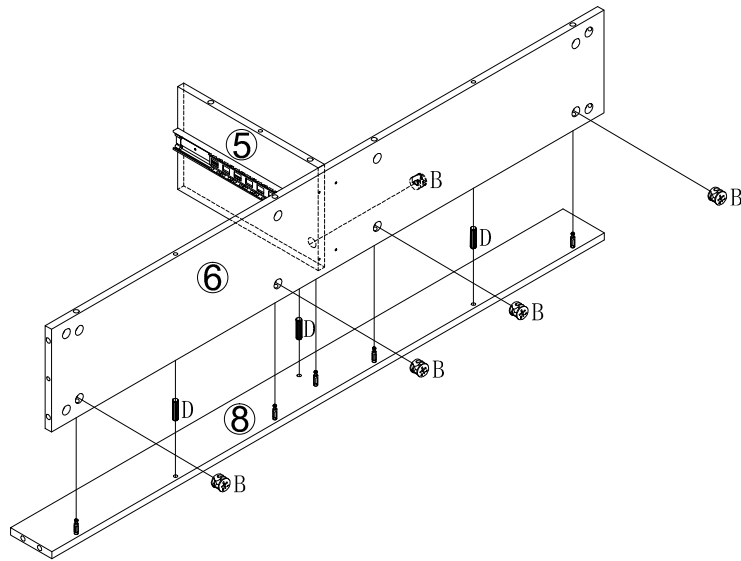

No. B
Quantity: 5 Pcs
Ø15



No. D
Quantity: 3 Pcs
6*30mm

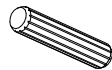

STEP 8

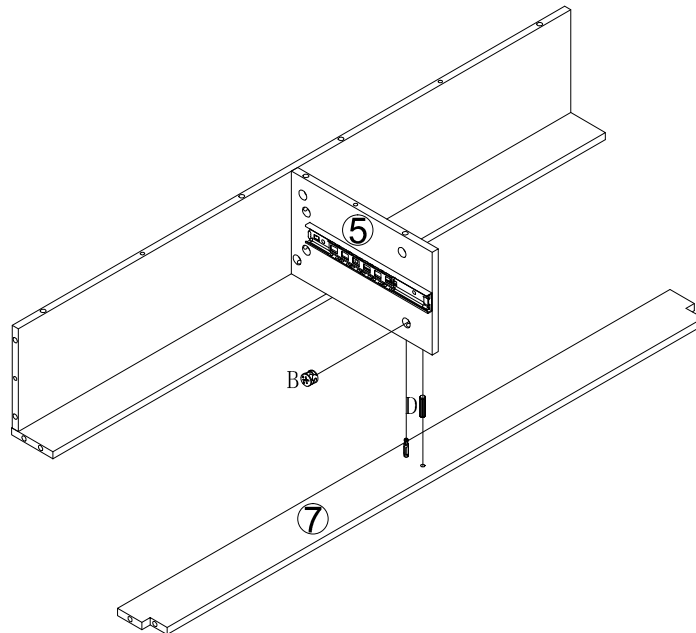

No. B
Quantity: 1 Pcs
Ø15



No. D
Quantity: 1 Pcs
6*30mm

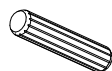

STEP 9

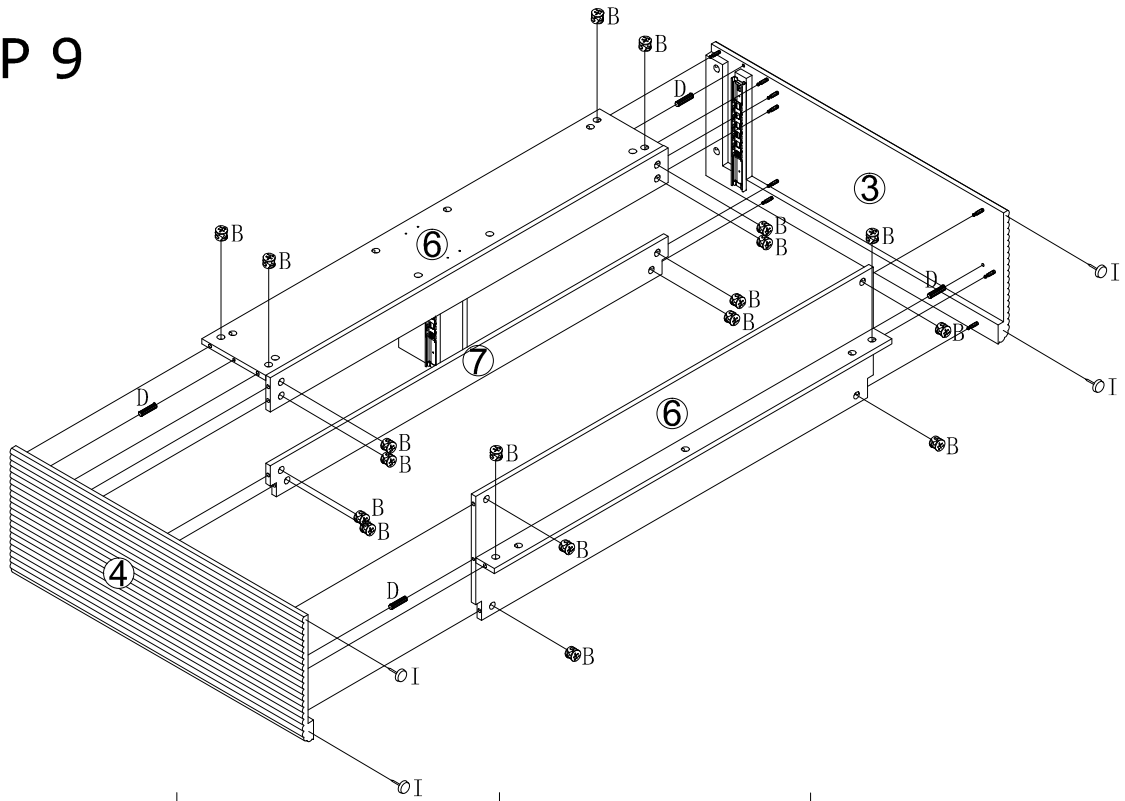

No. B
Quantity: 18 Pcs
Ø15



No. D
Quantity: 4 Pcs
6*30mm

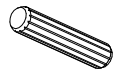

No. I
Quantity: 4 Pcs



STEP 10

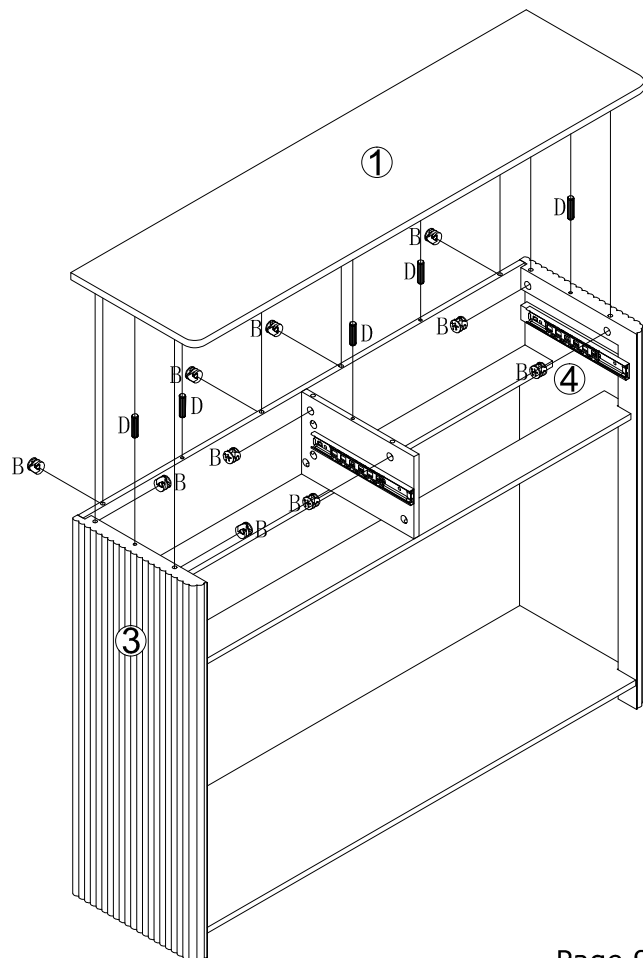

No. B
Quantity: 10 Pcs
Ø15



No. D
Quantity: 5 Pcs
6*30mm

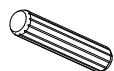

STEP 11

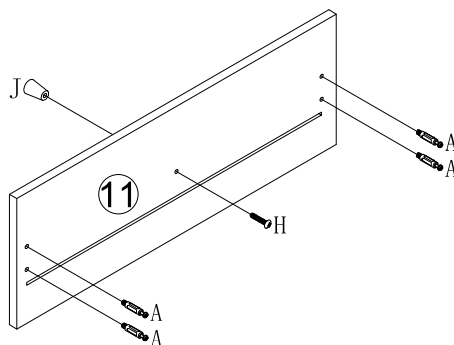
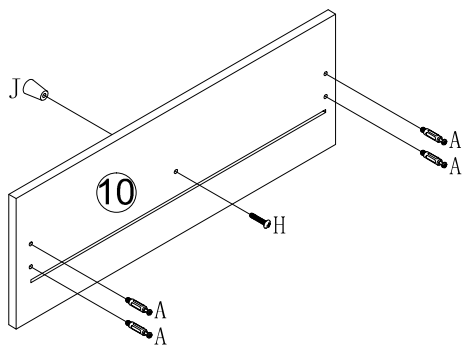

No. A
Quantity: 8 Pcs
8*28 mm



No. H
Quantity: 2 Pcs
M4*16mm



No. J
Quantity: 2 Pcs



STEP 12

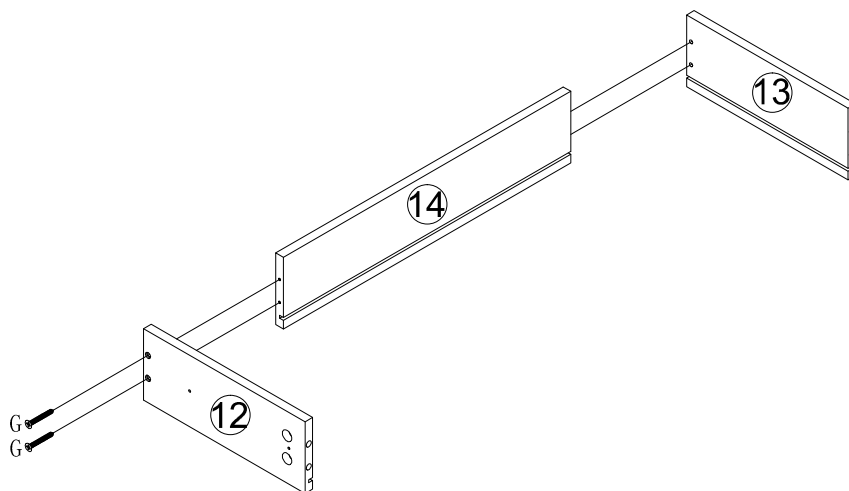

No. G
Quantity: 8 Pcs
M4*30mm

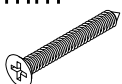

x2

STEP 13

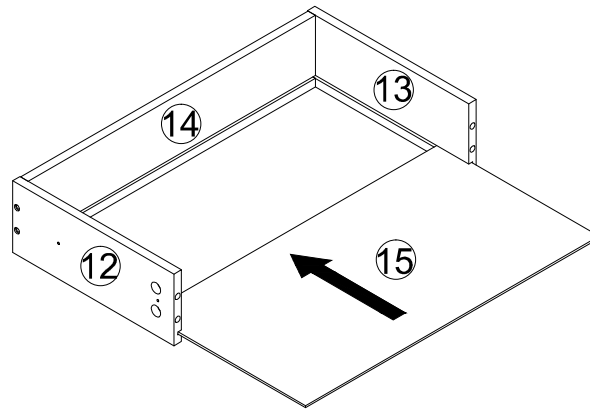

x2

STEP 14

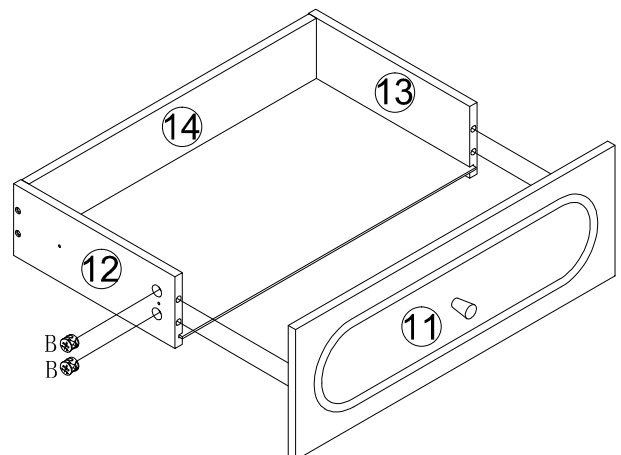
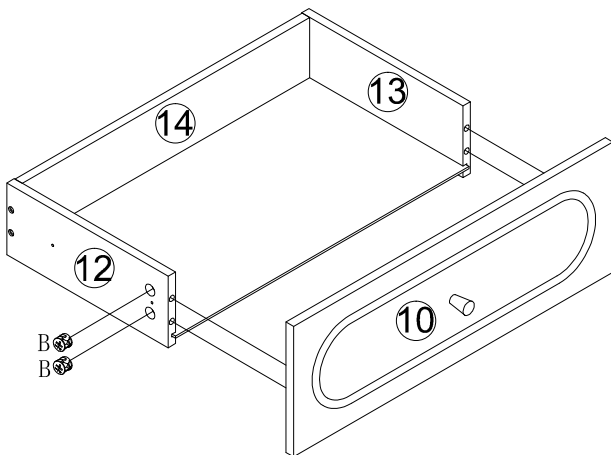

No. B
Quantity: 8 Pcs
Ø15



STEP 15



The first screw hole should corresponded with the board location hole

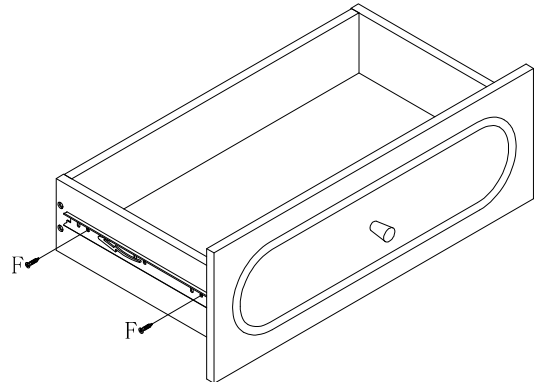
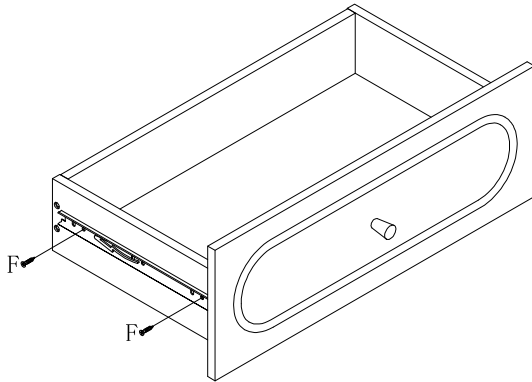

No. E
Quantity: 2 Sets
10"

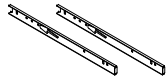

No. F
Quantity: 8 Pcs
M3.5*12mm



STEP 16

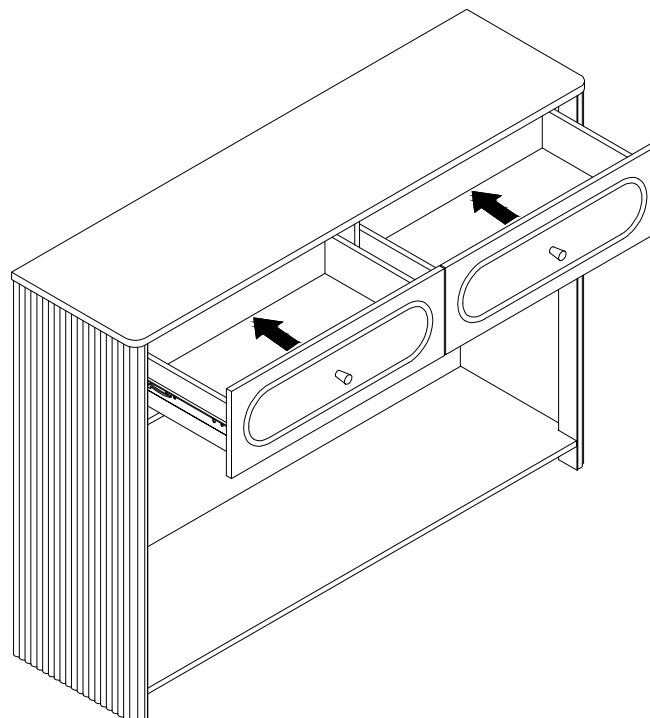

STEP 17

