

## Parts and Damage Replacement Procedure

1. Please inspect your purchase immediately.
2. This procedure covers product purchased from an authorized and was received in its originally sealed carton.
3. If you find a part missing or damaged, you have a 30-day window in which to order a replacement part from the date on your purchase receipt.
4. You have 3 ways to do this. You will need a copy of your purchase receipt.
  - a. By Fax: Fax the parts order form below and along with your receipt
  - b. By Email: Email the order form and along with your receipt
  - c. By Mail: Fill out the parts order form below and along with a copy of your receipt send it to furniture parts department
5. Once this order is sent in, you will be notified if the part(s) you are requesting can or cannot be shipped within 7-10 business days.

**A COPY OF YOUR PURCHASE RECEIPT OR INVOICE MUST BE ATTACHED TO THIS ORDER FORM.  
NO ORDERS WILL BE PROCESSED WITHOUT PROOF OF PURCHASE.**

NAME: \_\_\_\_\_

ADDRESS: \_\_\_\_\_ (No Post Office Boxes)

CITY: \_\_\_\_\_ STATE: \_\_\_\_\_ ZIP: \_\_\_\_\_

PHONE: \_\_\_\_\_ FAX: \_\_\_\_\_

EMAIL: \_\_\_\_\_

**REASON FOR REPLACEMENT/PLEASE CHECK APPROPRIATE BOX.**

- Damaged /scratched, cracked, broken, crushed, etc.
- Mechanical malfunction/ drawer glides, swivel mechanisms, lid stays, etc.
- Missing pieces
- Unfinished surface
- Wrong color
- Other

IF MORE THAN ONE MODEL NUMBER IS LISTED ABOVE, PLEASE SPECIFY THE EXACT MODEL NUMBER OF YOUR ITEM IN THE SPACE PROVIDED BELOW.

| Model Number | Part Letter Code | Quantity |
|--------------|------------------|----------|
|              |                  |          |
|              |                  |          |
|              |                  |          |

# NIGHTSTAND

## ASSEMBLY INSTRUCTION

### NIGHTSTAND



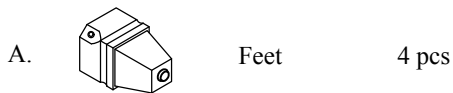

Thank you for purchasing this quality product. Be sure to check all packing material carefully for small Hardware which may have come loose inside the carton during shipment. Identify and count all Hardware and compare with the Hardware List below.

**Note :** Take out assembly instructions sheet, hardware pack and feet packaging from the drawer which marked with the rope.

#### COMPONENT LIST



#### HARDWARE

- |    |   |                          |       |
|----|---|--------------------------|-------|
| 1. |  | JCBC Screw M6 x 50mm     | 4 pcs |
| 2. |  | Spring Washer Ø1/4"      | 4 pcs |
| 3. |  | Flat Washer Ø1/4" x 20mm | 4 pcs |
| 4. |  | L Key M4                 | 1 pc  |

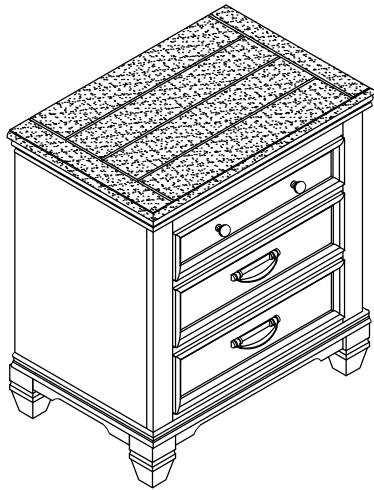

**ASSEMBLY COMPLETED**

#### STEP 1

Place lay down the Nightstand on the floor.

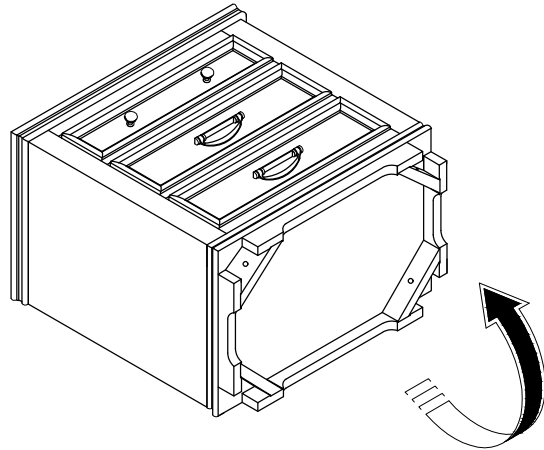

#### STEP 2

Align feet (A) to Nightstand. Fasten the feet using JCBC Screw (1), Spring washer (2) and flat washer (3) and fully tighten with L key (4).

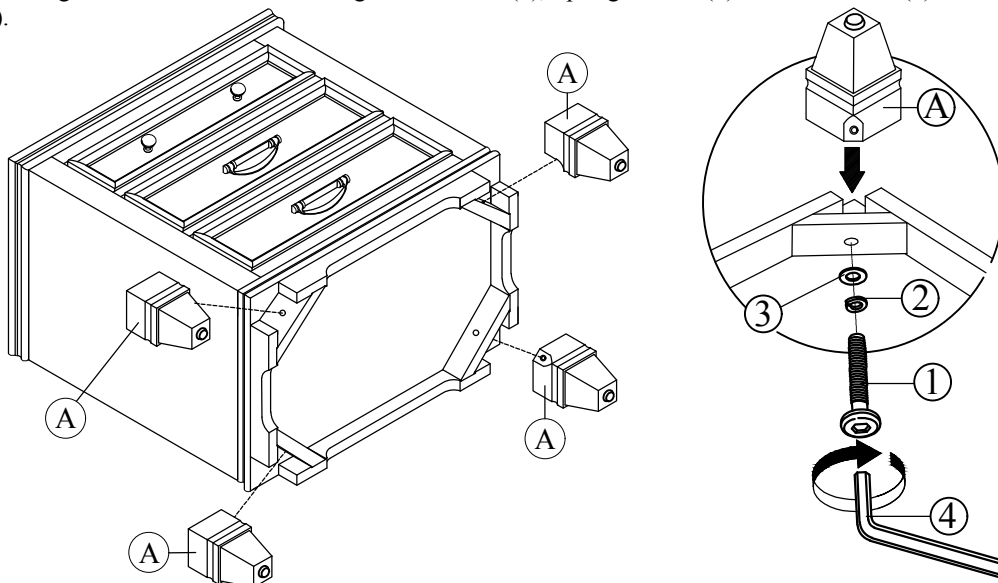

**NOTE : MUST TIGHTEN SCREWS PERIODICALLY WITH USE SCREW WILL BECOME LOOSE.  
CHECK TIGHTNESS OF ALL SCREW EVERY 6-8 WEEKS.**