

# ASSEMBLY INSTRUCTION

## ITEM DESCRIPTION:BARSTOOL

### DO NOT TIGHTEN SCREWS UNTIL COMPLETELY ASSEMBLED

This page lists all the contents included in the box. Please take the time to identify the hardware as well as the individual components to this product. As you unpack and prepare for assembly, place the contents on a carpeted or padded area to protect them from damage.

**Cleaning & care** Treat surface with care. Surface is resistant to scratches but is not scratch resistant. Clean surfaces with a dry or damp soft cloth. Do not use abrasive cleaners. Hardware may loosen over time. Periodically check that all connections are tight.

Place chair on flat surface and adjust seat and legs until the chair sits even on the floor. After the chair is level, tighten the screws. Periodically check and tighten the screws

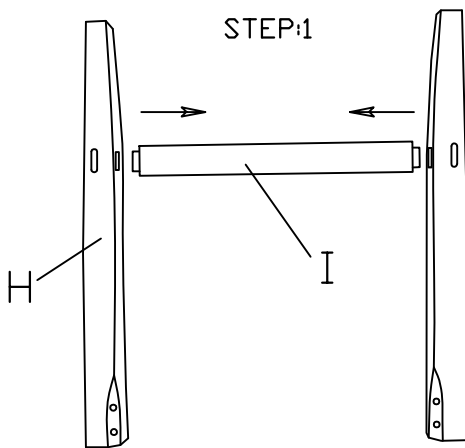

- to insure proper assembly, do not fully tighten screws until chair is fully assembled. Tighten the screws about 80% during assembly process.
- place chair on flat surface and adjust seat and legs until the chair sits even on the floor.
- after the chair is level, tighten the screws
- screws will loosen with time and usage, periodically check and tighten the screws.

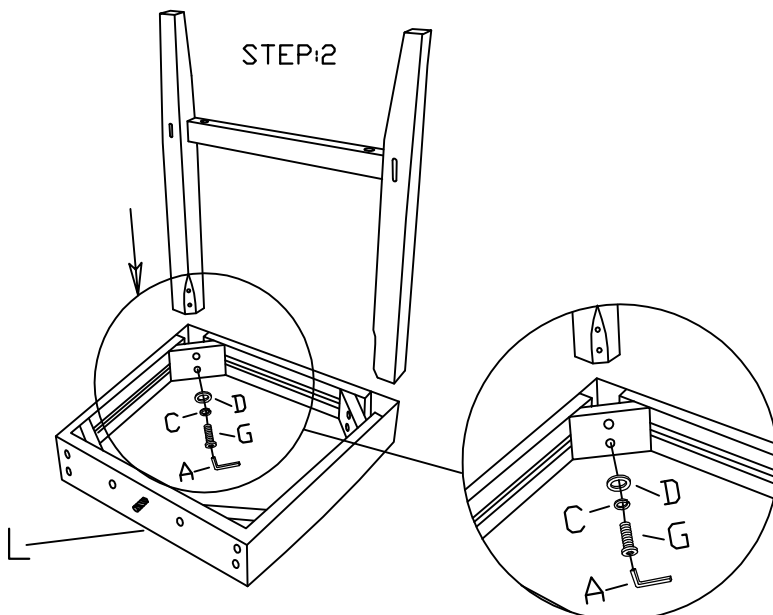

**STEP 1:** Find out 2 pcs of front legs (H) 1pc of front stretcher. see the drawing, attach the 2 front legs (H) and front stretcher (I).

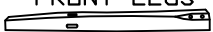
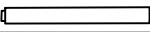
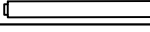
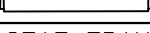

**STEP 2:** A. Put the seat frame (L) on a smooth flat surface. attach the two front legs with front stretcher to the seat frame, use Bolt (G), lock washer (C) flat washer (D) in the both of hole of seat frame and the front leg. Tighten the Allen wrench (A), in bolt (G) but not too tight.

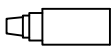
No	DESCRIPTION	Q'TY
A	ALLEN WRENCH ø5/16"	1PC
B	BOLT 1-3/4	6PCS
C	LOCK WASHER ø5/16"	10PCS
D	FLAT WASHER ø5/16"	10PCS
E	BOLT 1/4"DIA ø5/16"X2-1/4	2PCS
F	BOLT 1/4"DIA ø5/16"X3-1/2"	4PCS
G	BOLT 1/4"DIA ø5/16"X2-1/2	4PCS
H	FRONT LEGS 	2PCS
I	FRONT STRETCHER 	1PC
J	LEFT STRETCHER 	1PC
K	RIGHT STRETCHER 	1PC
L	SEAT FRAME 	1PC
M	CHAIR BACK 	1PC
N	GLUEWATER 	1PC

STEP:3

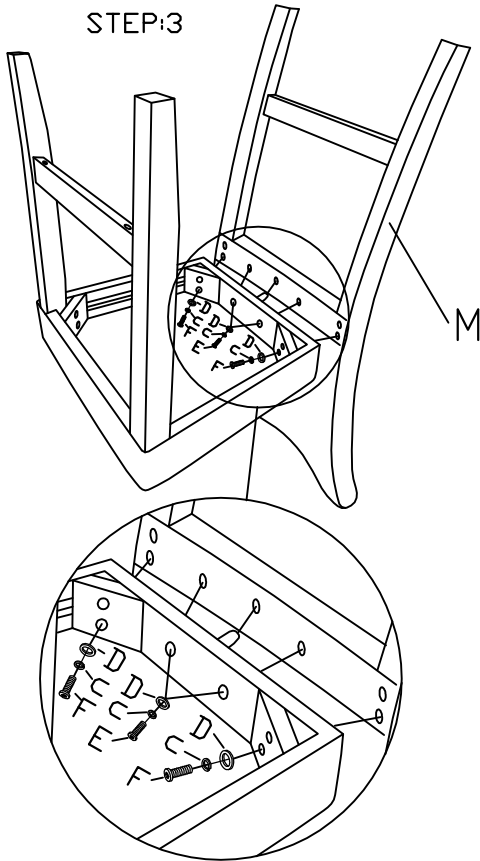

STEP 3:A.Put the chair back (M) on a smooth flat surface, attach the seat frame (L) to the chair back (M), use bolt (E),lock washer (C) and flat washer (D) in both of hole of seat frame (L) and chair back (M). turn the Allen wrench (A) in Bolt (E), but ont too tight.

B.Use the Bolt (F), lock washer (C) and flat washer (D)in the both of hole of weat frame (L) and chair back, turn the Allen wrench (A) in Bolt (F). but not too tight.

STEP:4

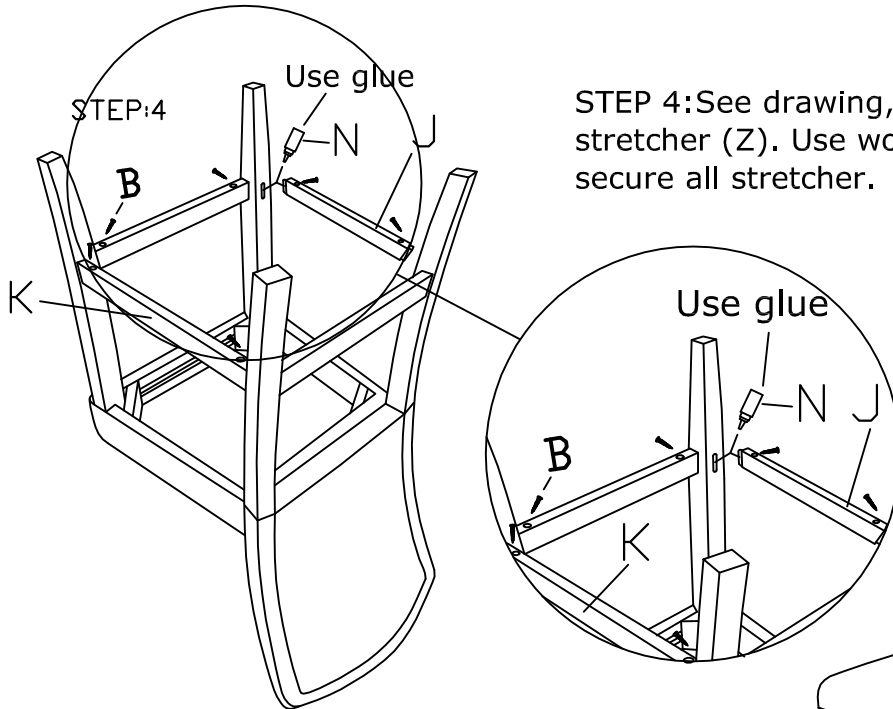

STEP 4:See drawing, assemble the left stretcher (Z). Use wood screw (Z) to secure all stretcher.

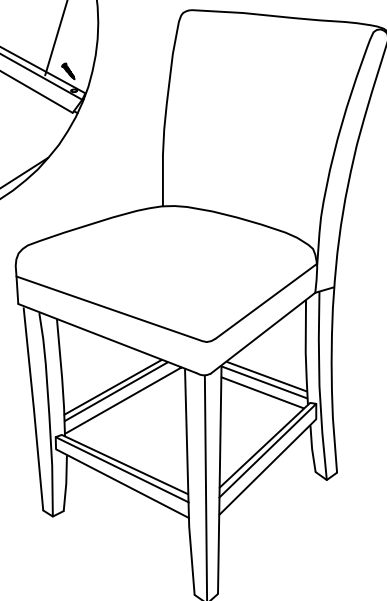

NOTE: DO NOT PUT THE MOIST AND HIGH TEMPERATURE AREA. NO BARGE AGAINST WITH HARD OBJECT.