

# Assembly Instructions

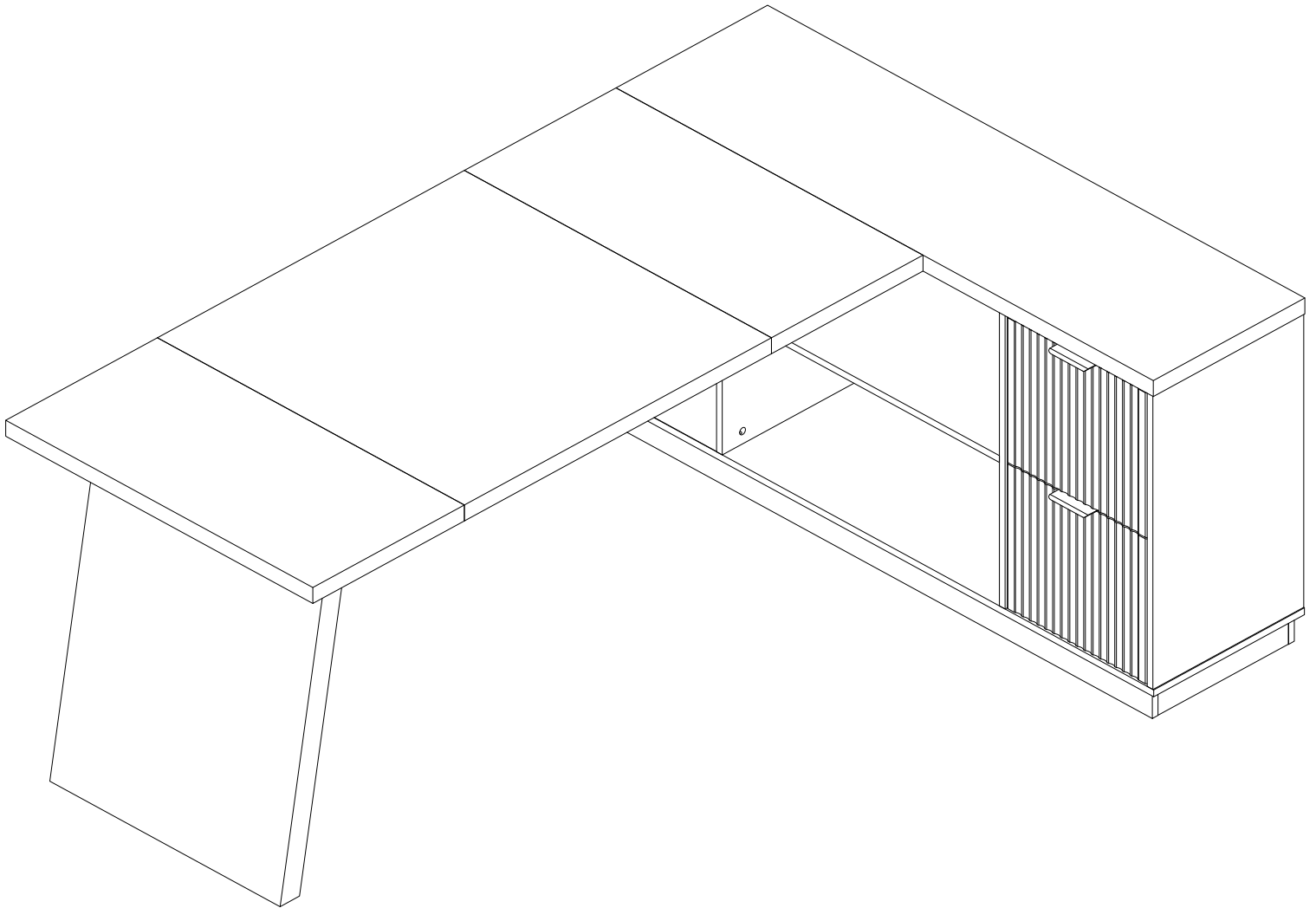

---

**Executive Desk**

---



## Warm Tips

1. Carefully read these instructions and keep them for future reference.
2. Check the parts list and confirm everything's there before starting assembly.
3. When assembling, put all parts on a soft, smooth surface like a carpet to avoid scratches.
4. Don't fully tighten screws until all parts are confirmed in place to avoid misalignment.

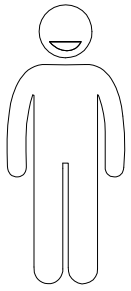

**X2**

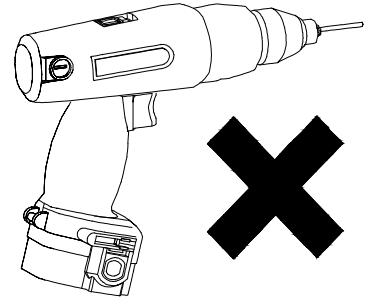
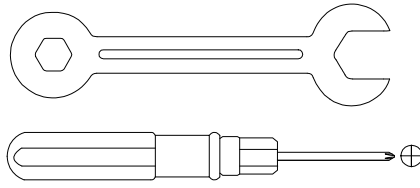

We recommend using hand tools for assembly.

If an electric screwdriver is used, reduce power and torque to avoid damage to the product.

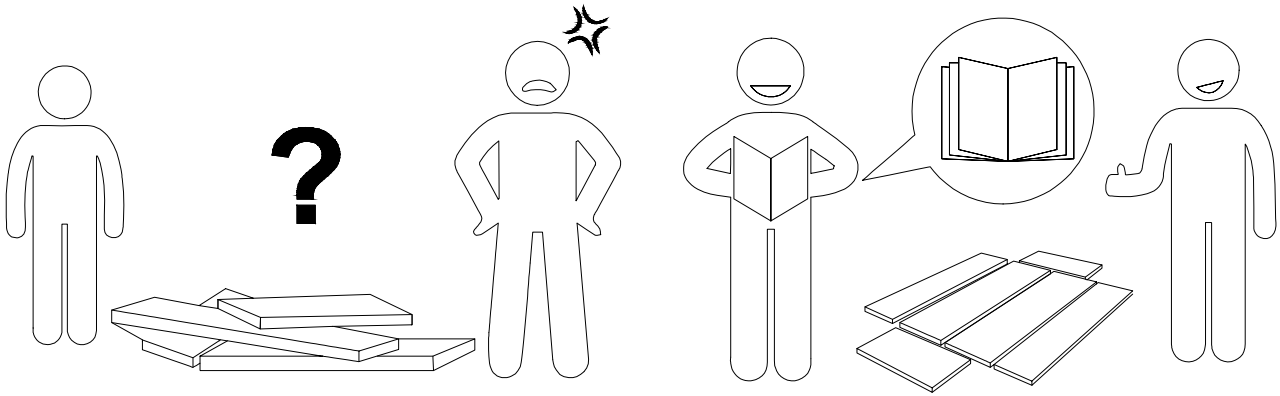

## AVOID SCRATCHES

In order to avoid scratching, this furniture should be assembled on a soft surface, such as a rug.

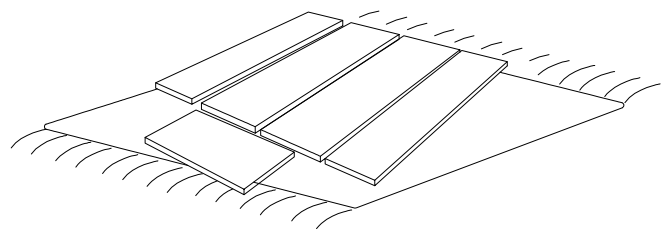
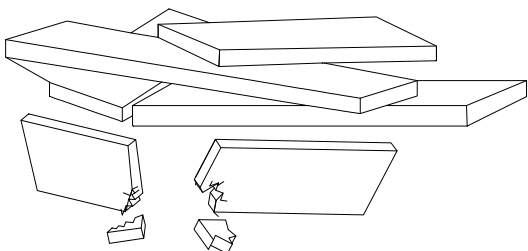

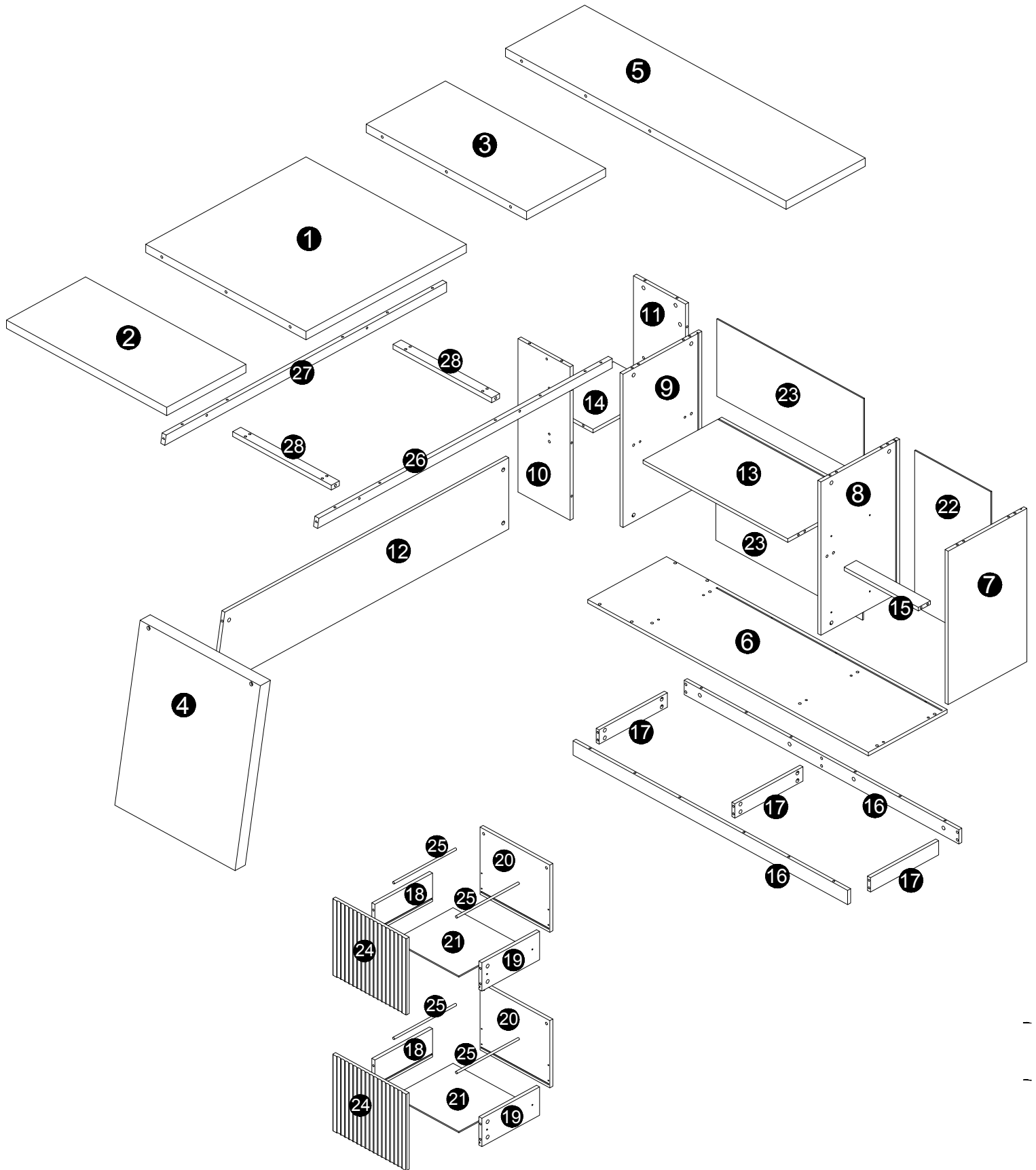

**⚠ Caution**

Make sure all parts are included. Most board parts are labeled or stamped on the raw edge. Contact us for a free replacement if you encounter any damaged or missing parts.

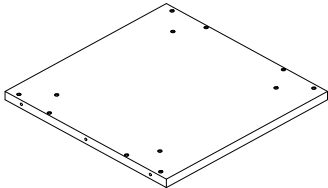
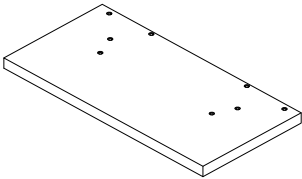
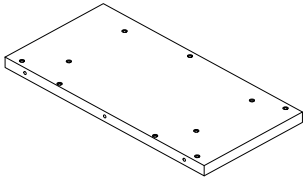
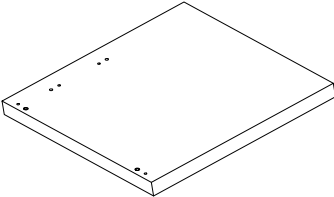
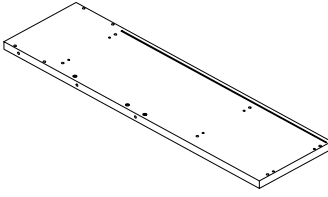
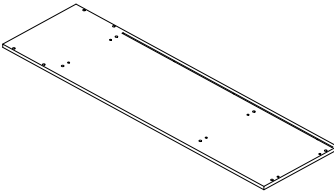
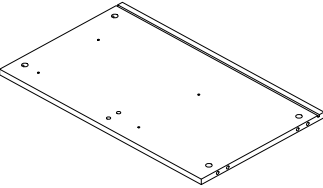
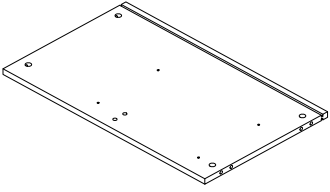
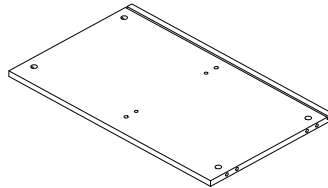
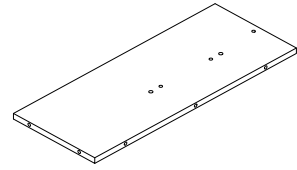
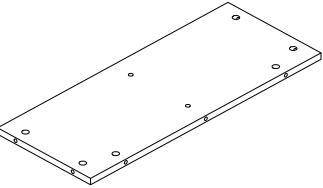
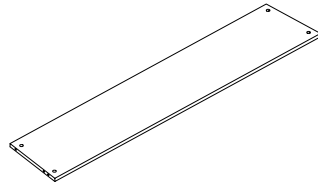
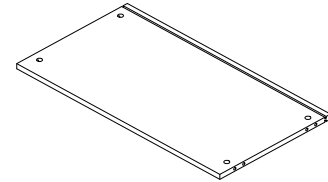
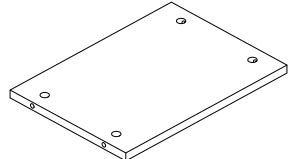
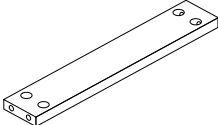
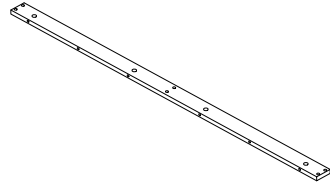
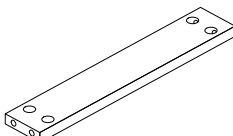
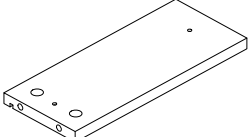
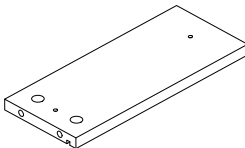
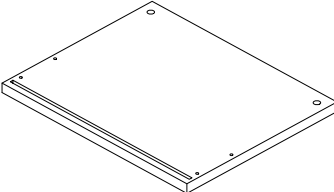

# Parts List

 <p>1pc</p>	 <p>1pc</p>	 <p>1pc</p>	 <p>1pc</p>
 <p>1pc</p>	 <p>1pc</p>	 <p>1pc</p>	 <p>1pc</p>
 <p>1pc</p>	 <p>1pc</p>	 <p>1pc</p>	 <p>1pc</p>
 <p>1pc</p>	 <p>1pc</p>	 <p>1pc</p>	 <p>2pcs</p>
 <p>3pcs</p>	 <p>2pcs</p>	 <p>2pcs</p>	 <p>2pcs</p>

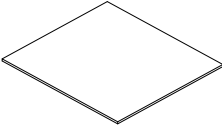
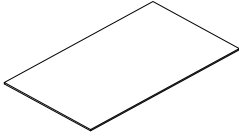
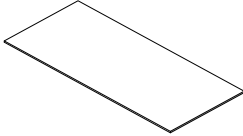
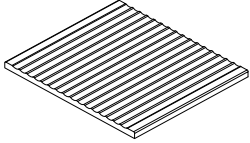
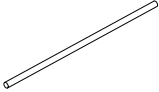
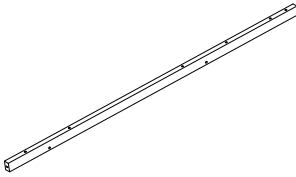
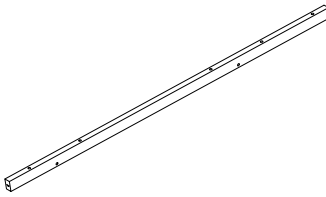
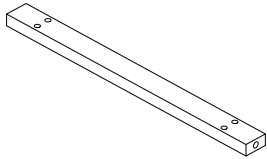

# Parts List

<p>21</p>  <p>2pcs</p>	<p>22</p>  <p>1pc</p>	<p>23</p>  <p>2pcs</p>	<p>24</p>  <p>2pcs</p>
<p>25</p>  <p>4pcs</p>	<p>26</p>  <p>1pc</p>	<p>27</p>  <p>1pc</p>	<p>28</p>  <p>2pcs</p>

**Before installation, please check if you have received the A and B packages, and check if the parts are complete.**





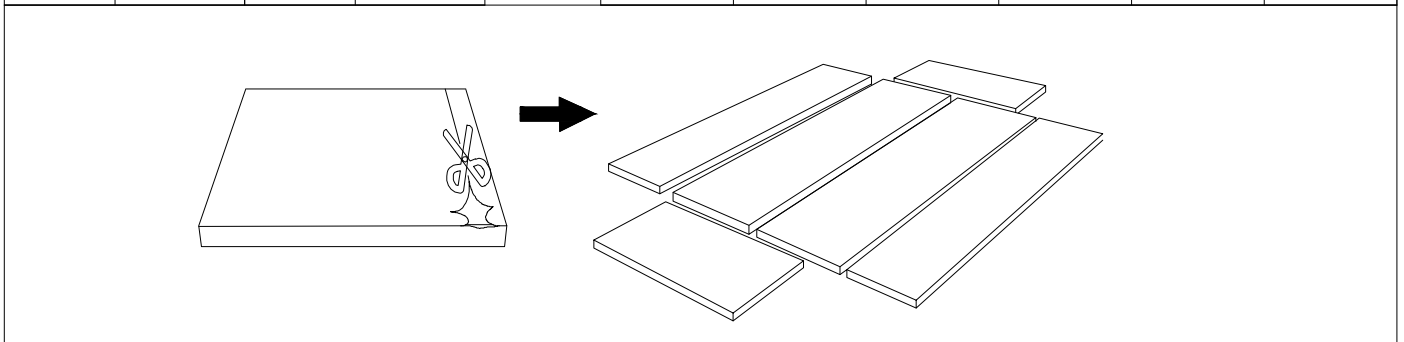





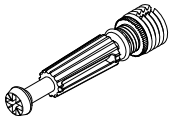
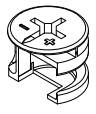
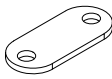
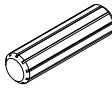

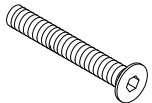
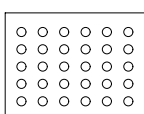
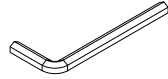
1	1pc	2	1pc
3	1pc	4	1pc
18	2pcs	19	2pcs
21	2pcs	22	1pc
25	4pcs	28	2pcs

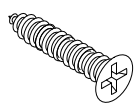
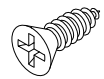
5	1pc	6	1pc	7	1pc
8	1pc	9	1pc	10	1pc
11	1pc	12	1pc	13	1pc
14	1pc	15	1pc	16	2pcs
17	3pcs	20	2pcs	23	2pcs
24	2pcs	26	1pc	27	1pc



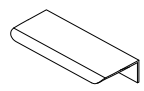

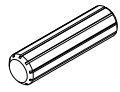
## Hardware List

A	B	C	D	E	F
 M6x40mm	 Ø15x12mm	 L56xW24xH2mm	 Ø8x30mm	 Ø6x16mm	 Ø6x35mm
68 pcs	68 pcs	6 pc	26+1 pcs	16 pcs	13 pc
G	H	I	J	K	L
 Ø6x55mm		 M3		 Ø3.5x35mm	 Ø3.5x14mm
13 pcs	68 pcs	1 pc	2 pcs	8 pcs	28+8 pcs
M	N	O	P	Q	R
		 L300mm	 L300mm		 Ø15x2mm
1 pc	2 pcs	2 sets	2 sets	2 pcs	6 pcs
S	T				
 Ø10x40mm	 Ø25x2mm				
9 pcs	2 pcs				



## Installation of Cams and Pins

Step 1-2: Align the plastic part with the mounting hole and press it in. If you can't press it in, loosen the screw counter clockwise or completely remove the screw from the plastic part and try again.  
Step 3-4: After pressing the plastic part into place, use a screwdriver to tighten the screw clockwise.

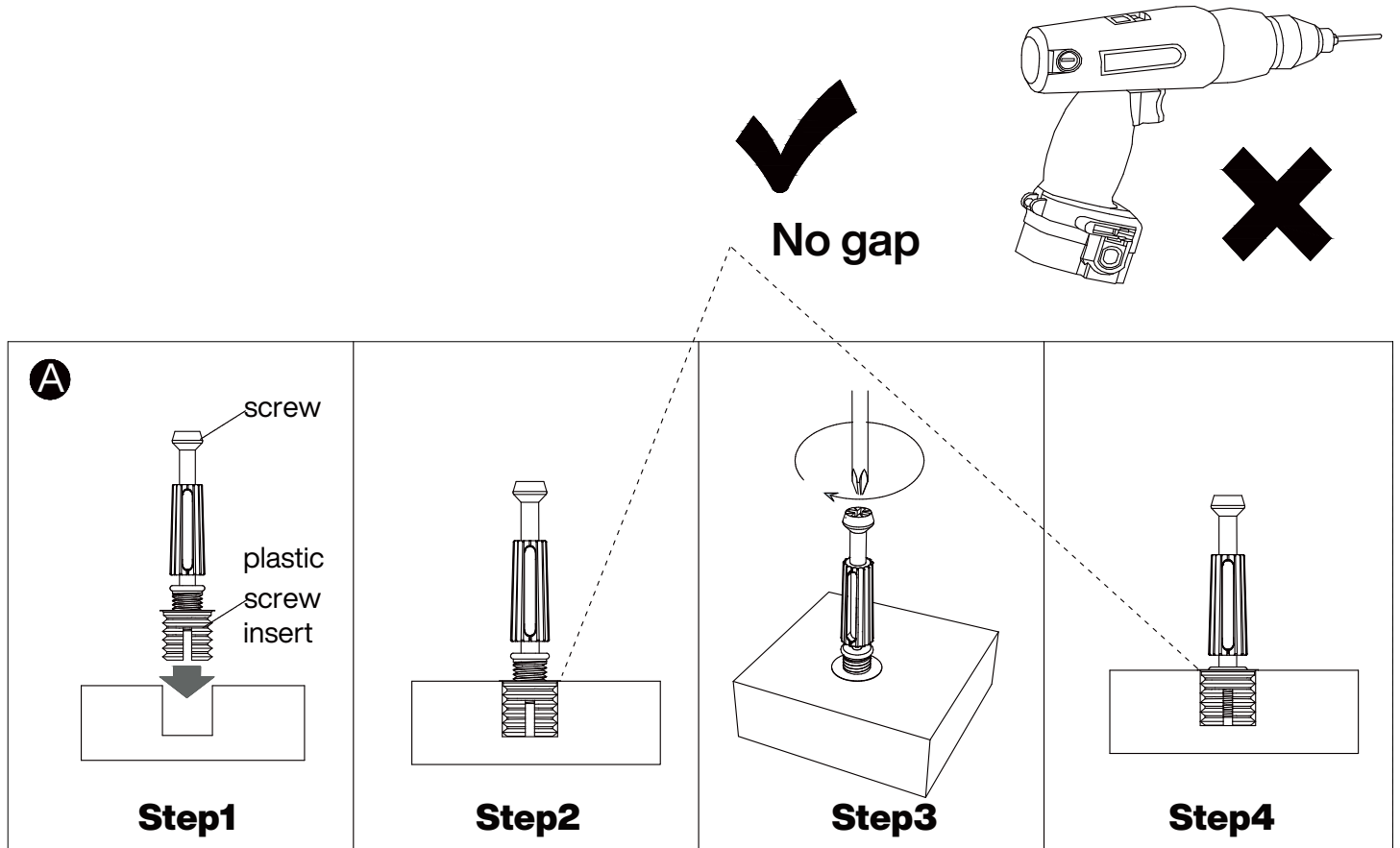

Screw the pin into the hole. Set the cams correctly by aligning the head of the cams with the lock pins. Lock the cam by turning the cam head with a screwdriver until it is tightened. Please do not use an electric screwdriver to assemble the unit.

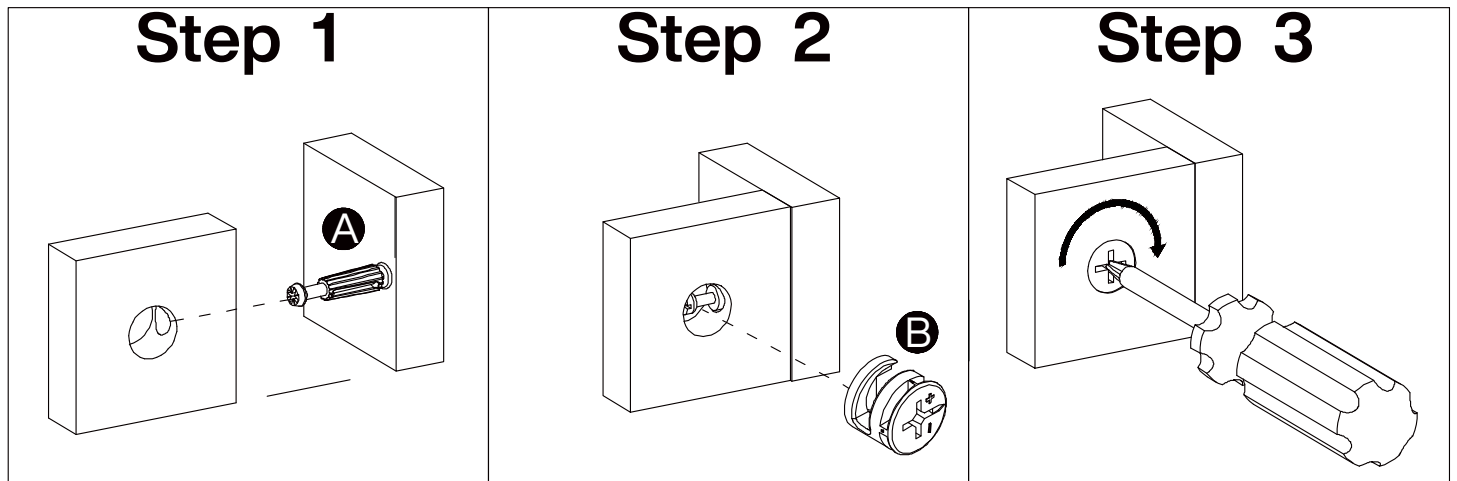



Please split component "O/P" into "O" and "P" before assembling the slide and then proceed to the next step of assembly

### Step 1

Pull apart component "O/P" to each side, and then gently push up the lever of component "P"

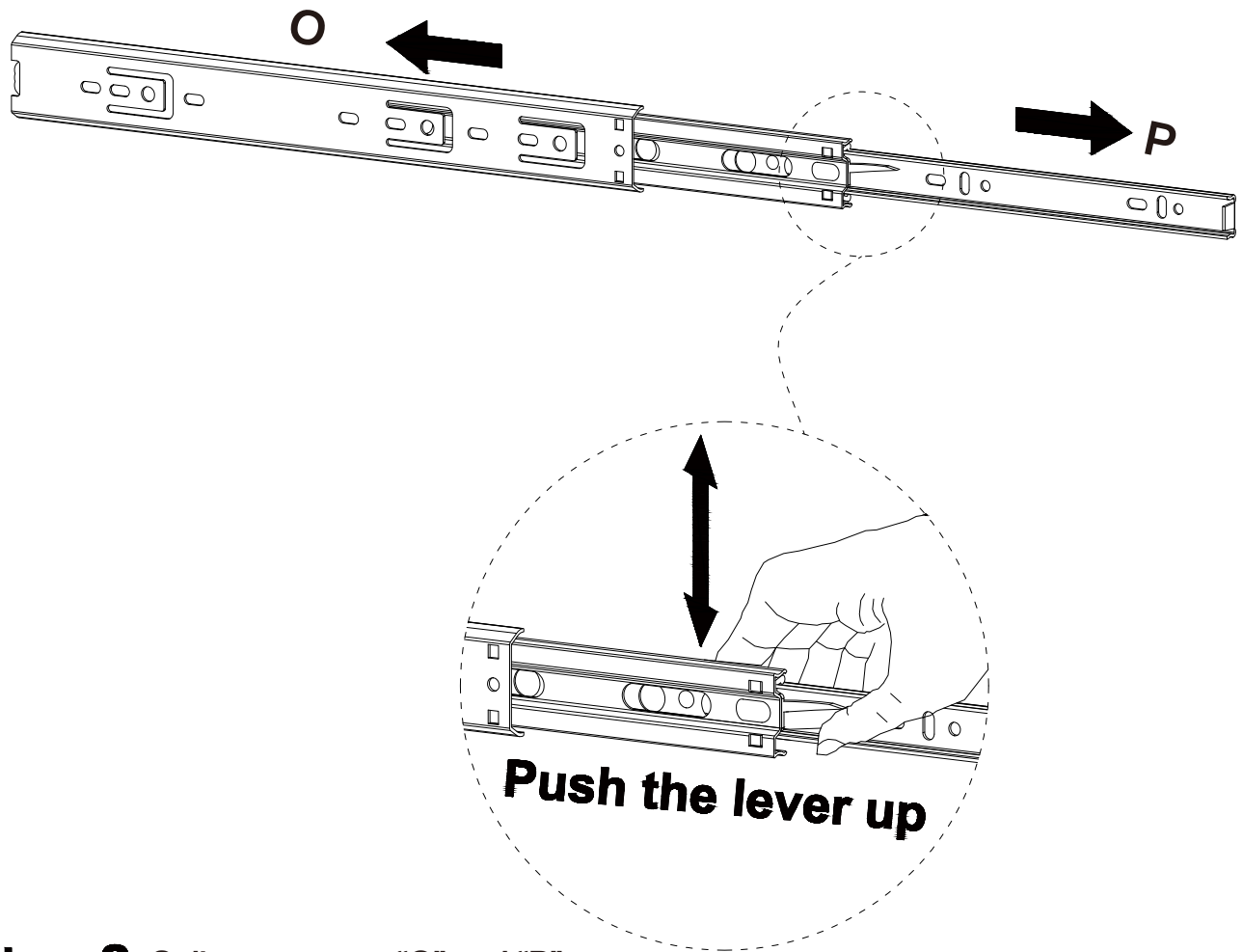

### Step 2 Split component "O" and "P"

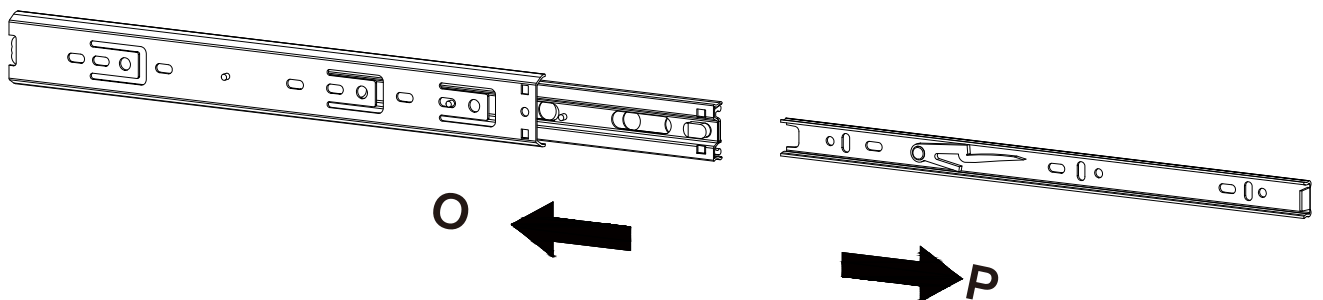



1

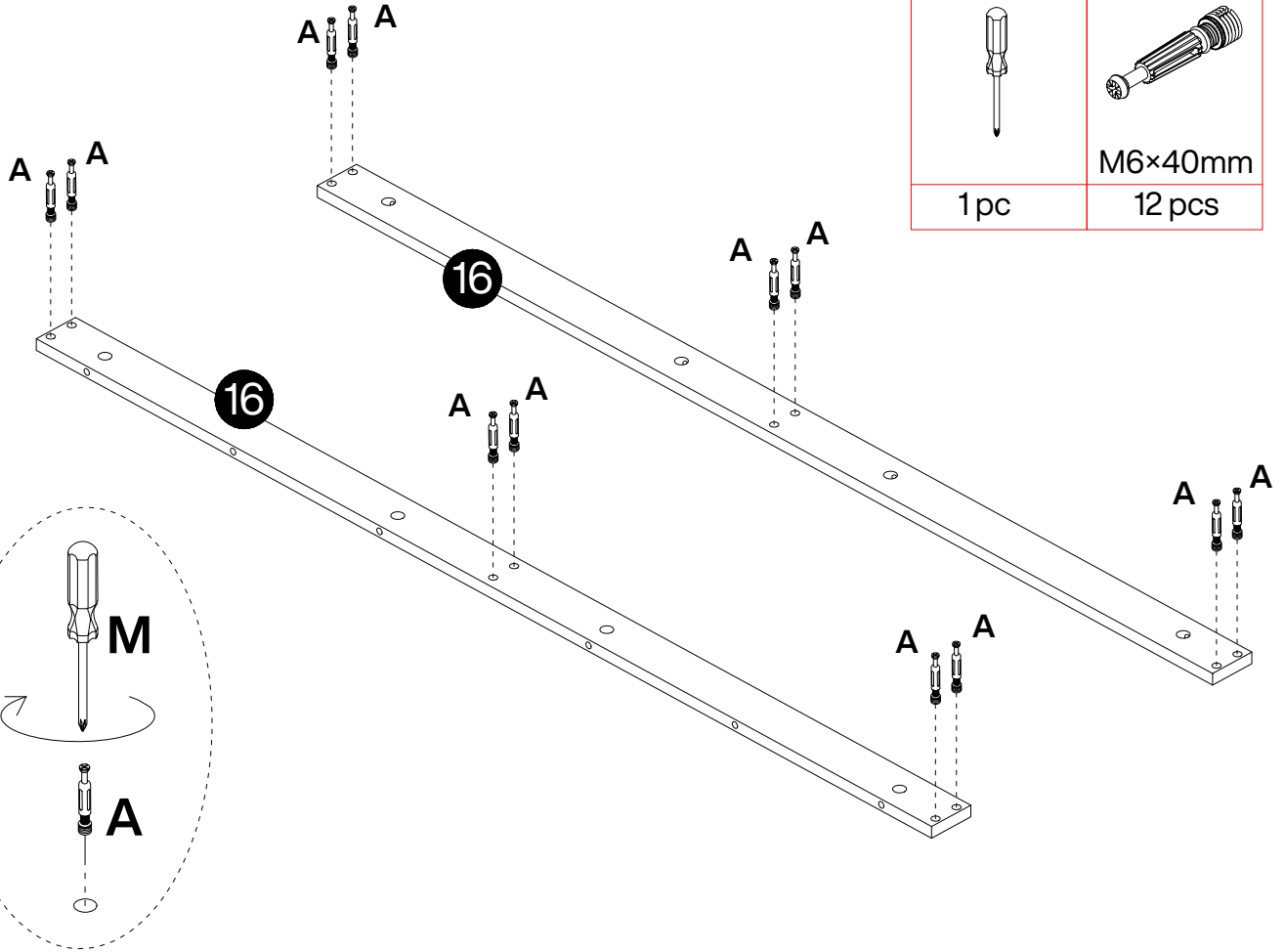

I	A
1 pc	M6×40mm 12 pcs

2

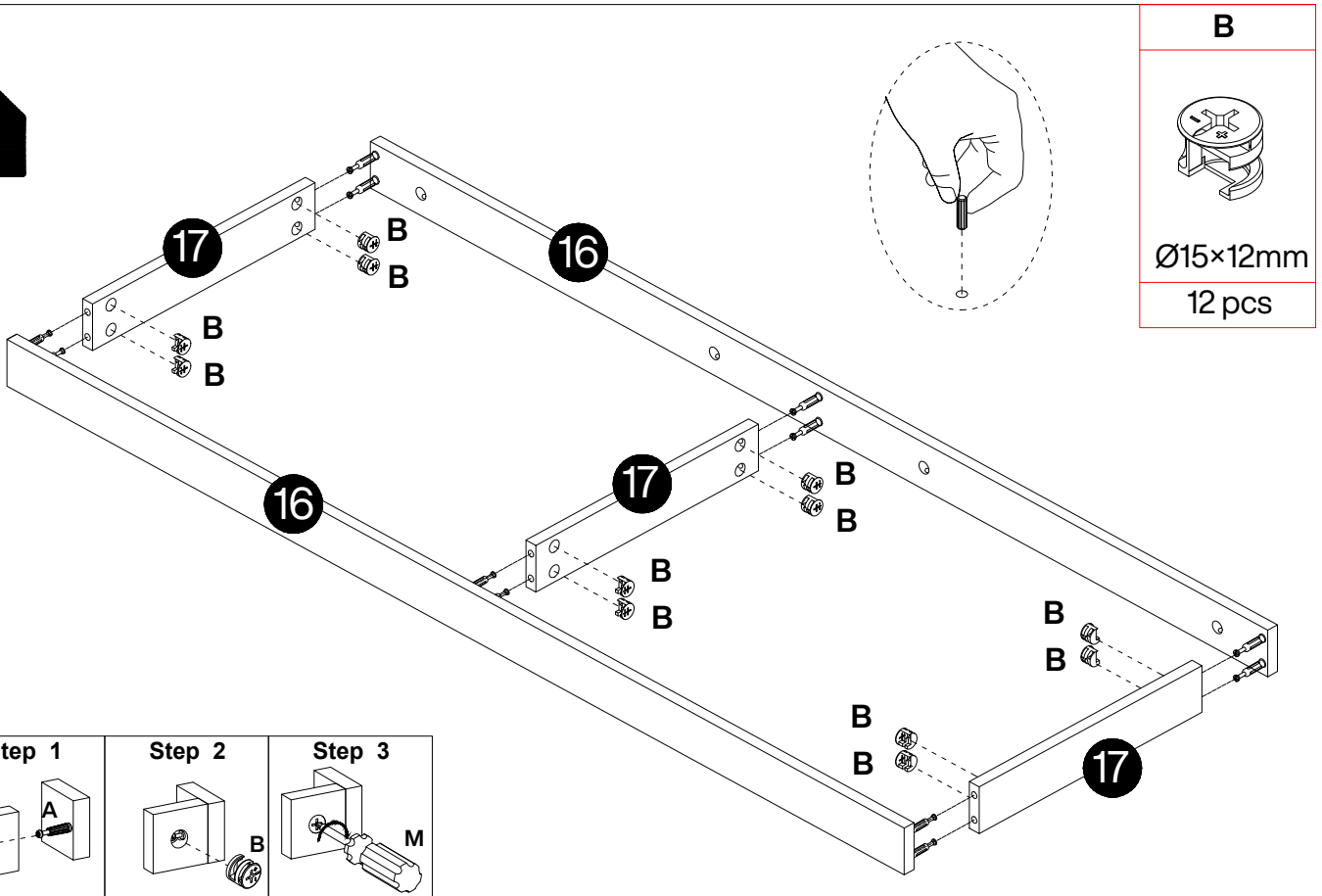

B
Ø15×12mm 12 pcs

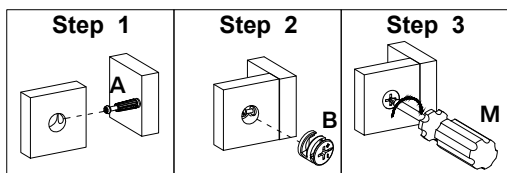



**3**

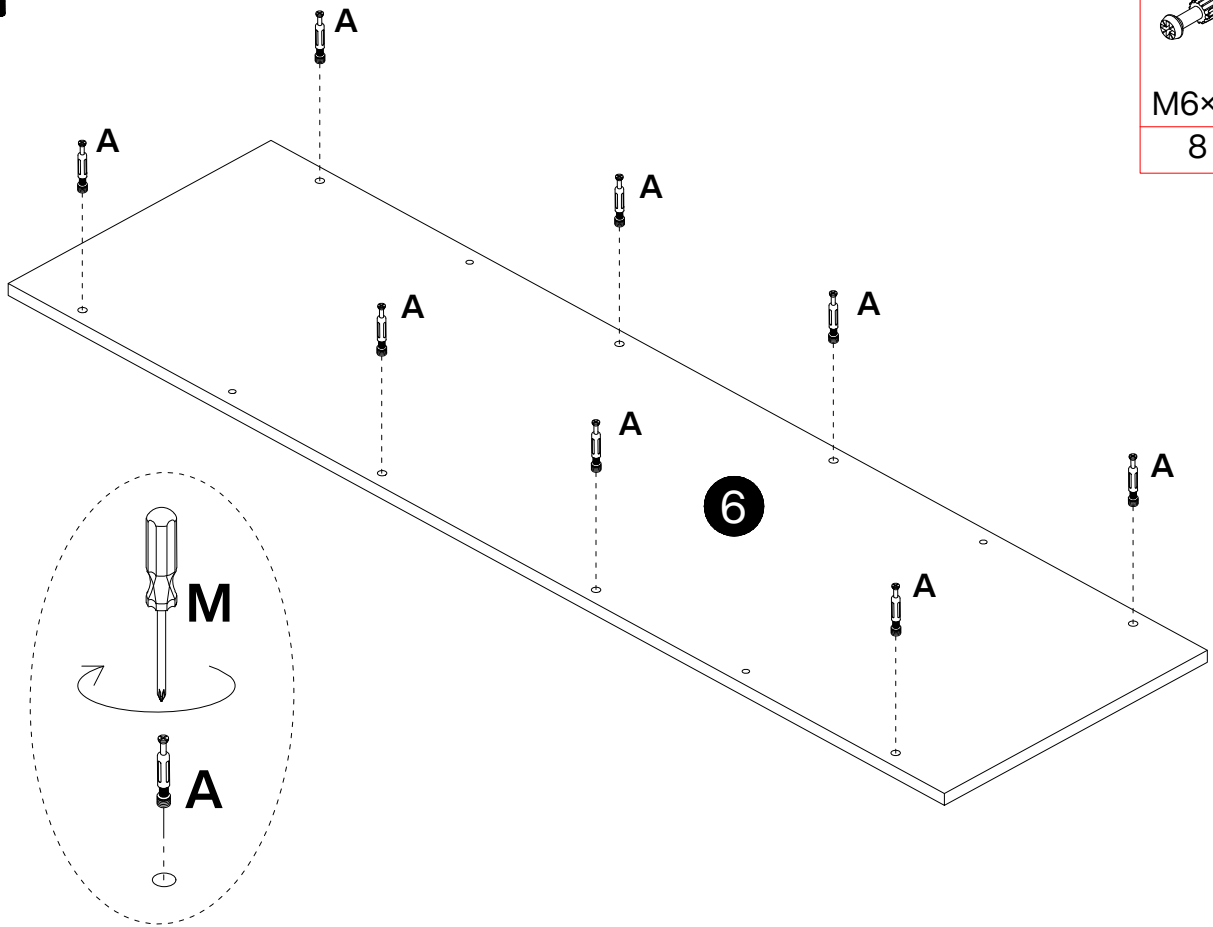

<b>A</b>

M6×40mm
8 pcs

**4**

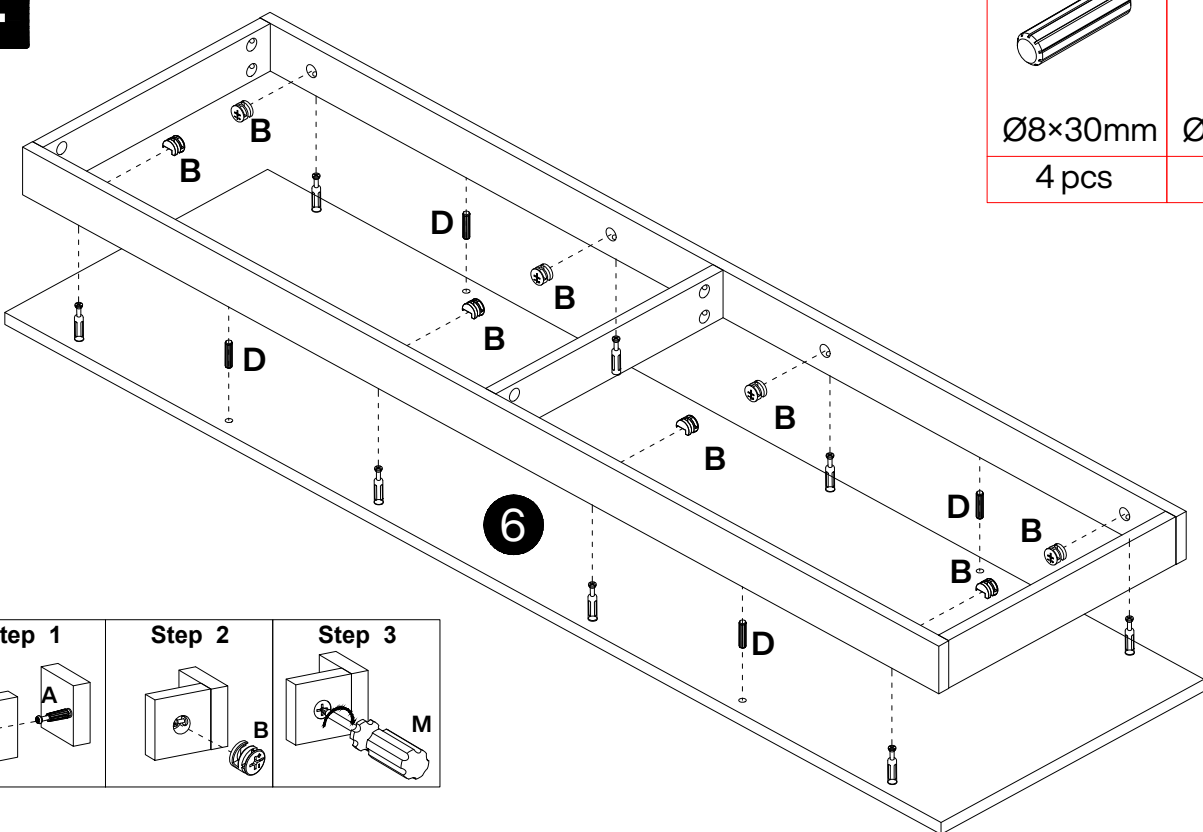

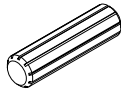
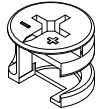

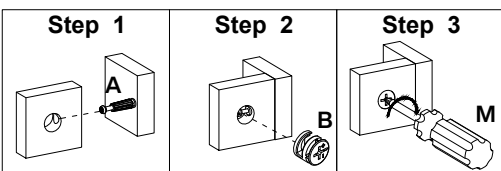
<b>D</b>	<b>B</b>
	
Ø8×30mm	Ø15×12mm
4 pcs	8 pcs



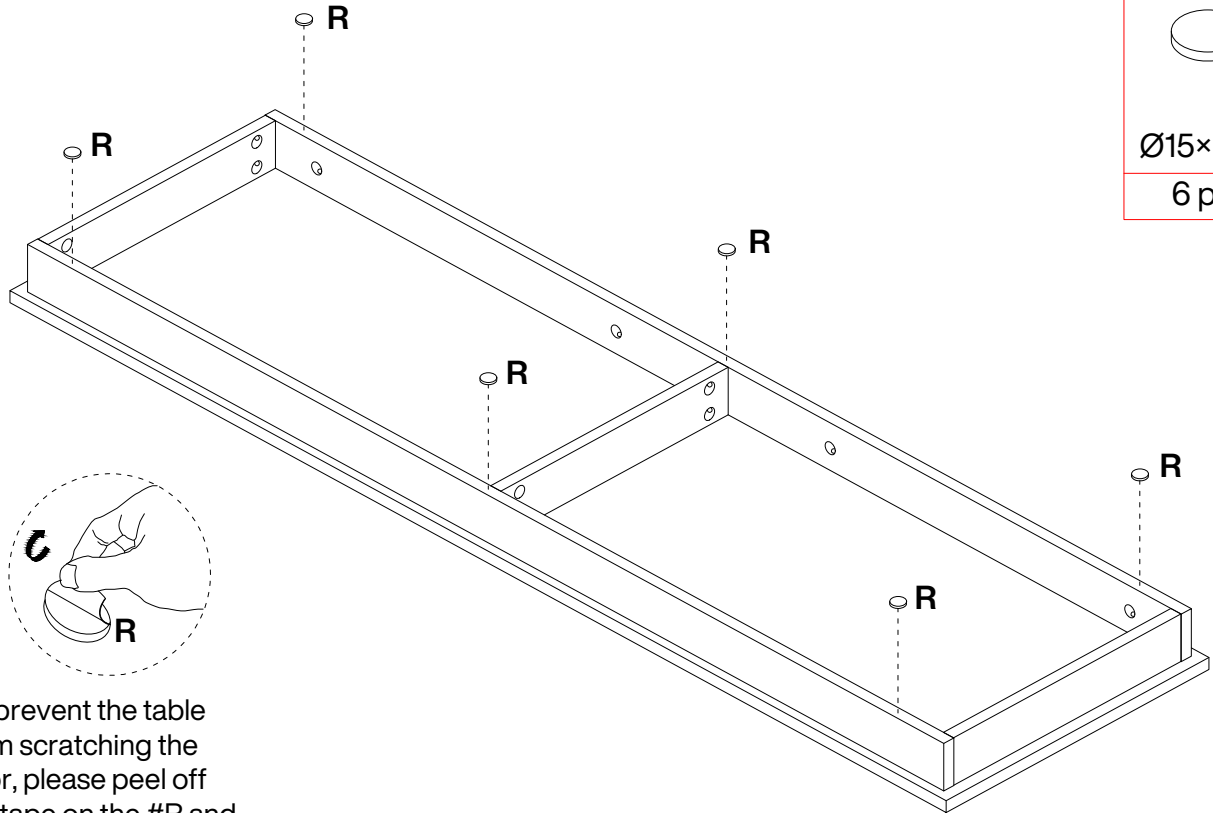

5



R

Ø15×2mm
6 pcs

To prevent the table from scratching the floor, please peel off the tape on the #R and tape them to the corners of the table before use.

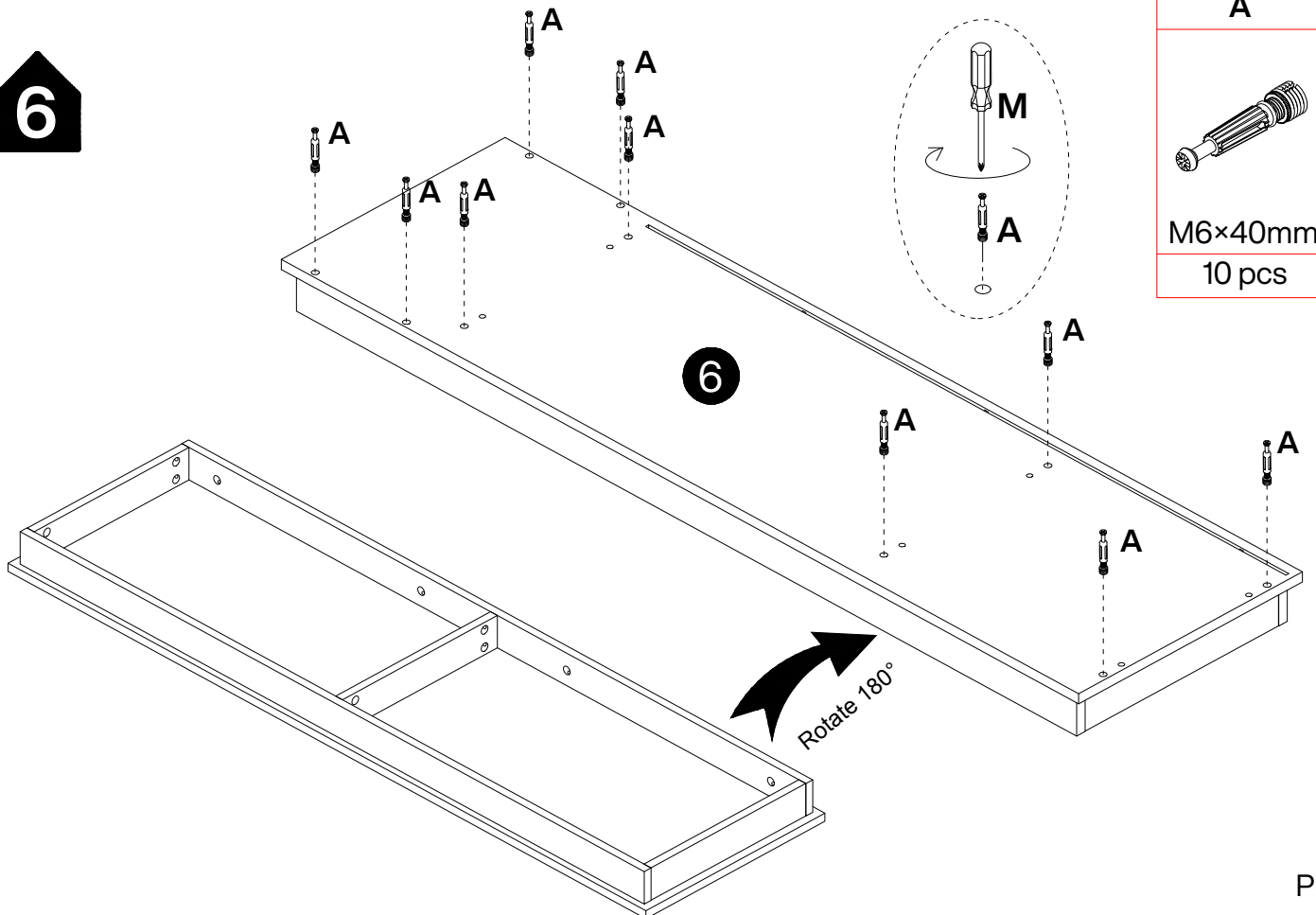
6

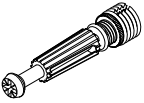

A

M6×40mm
10 pcs

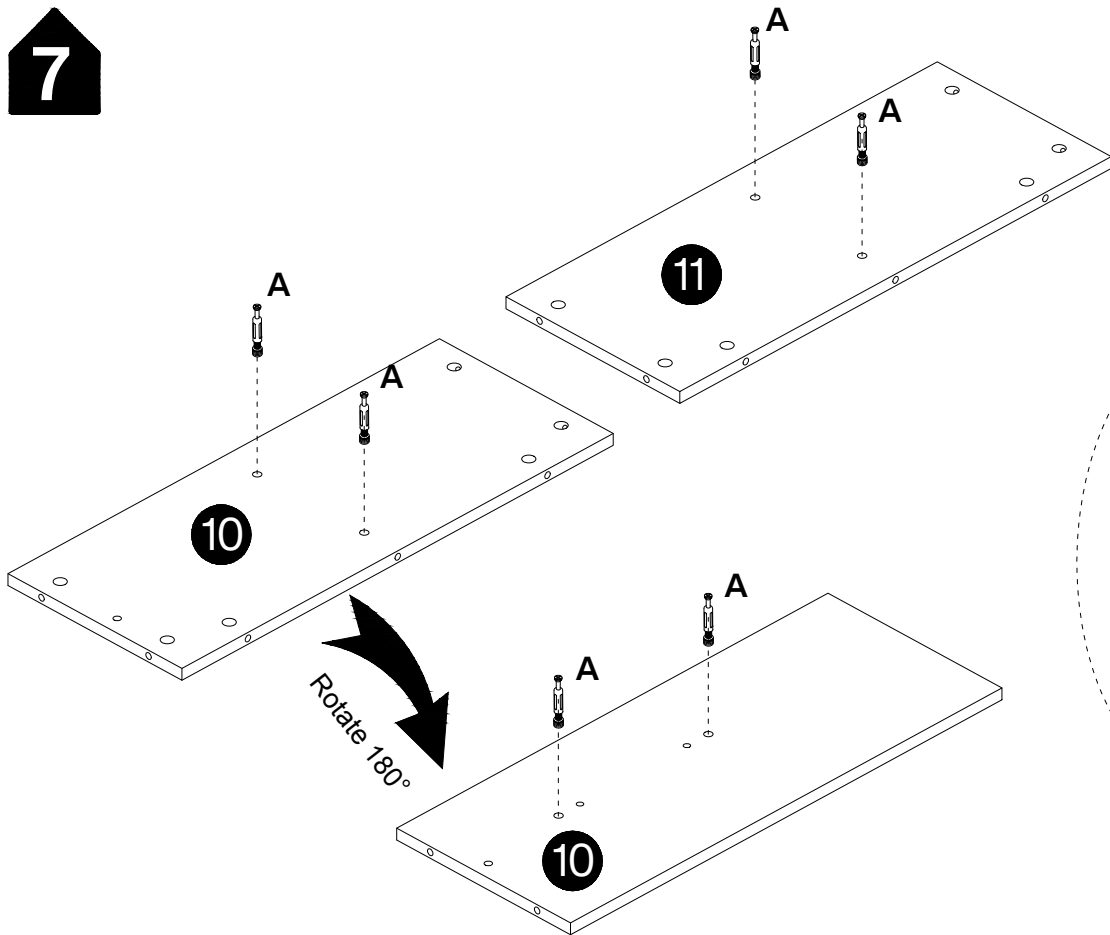

7

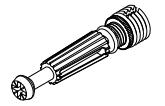

A



M6×40mm  
6 pcs

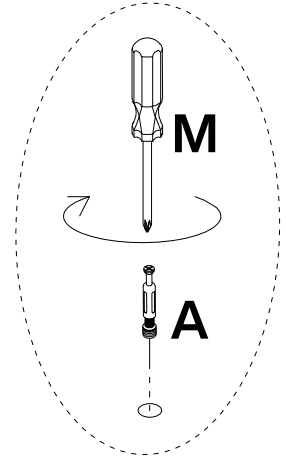

8

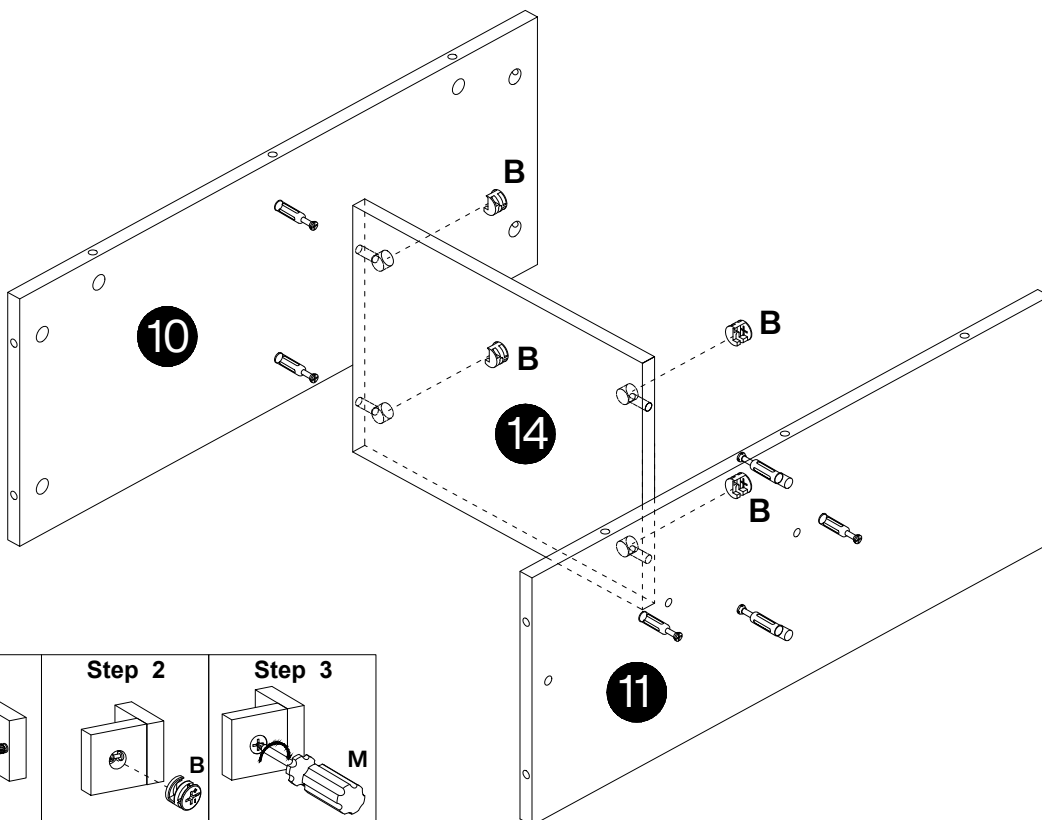

B

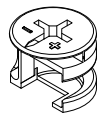

Ø15×12mm  
4 pcs

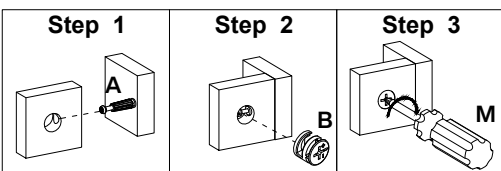



9

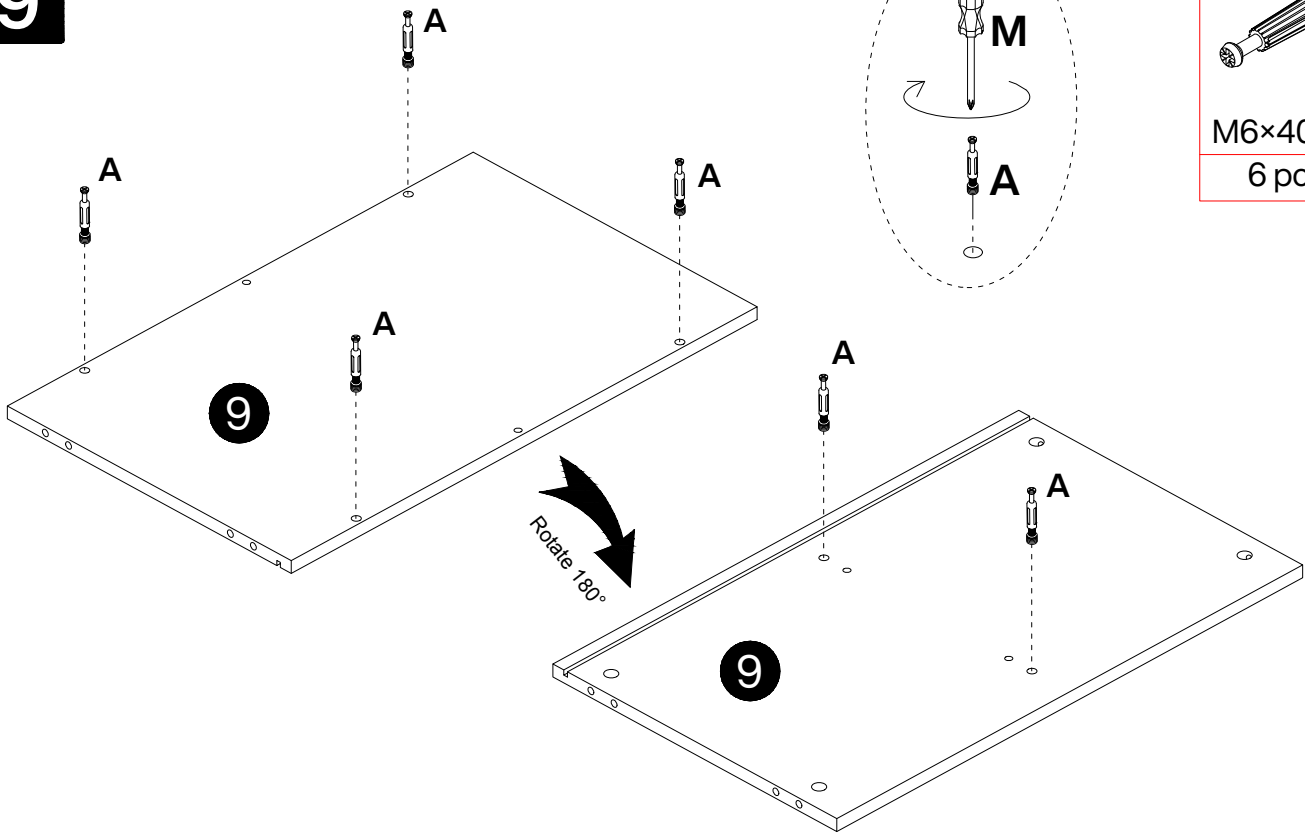

A

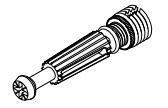

M6×40mm  
6 pcs

10

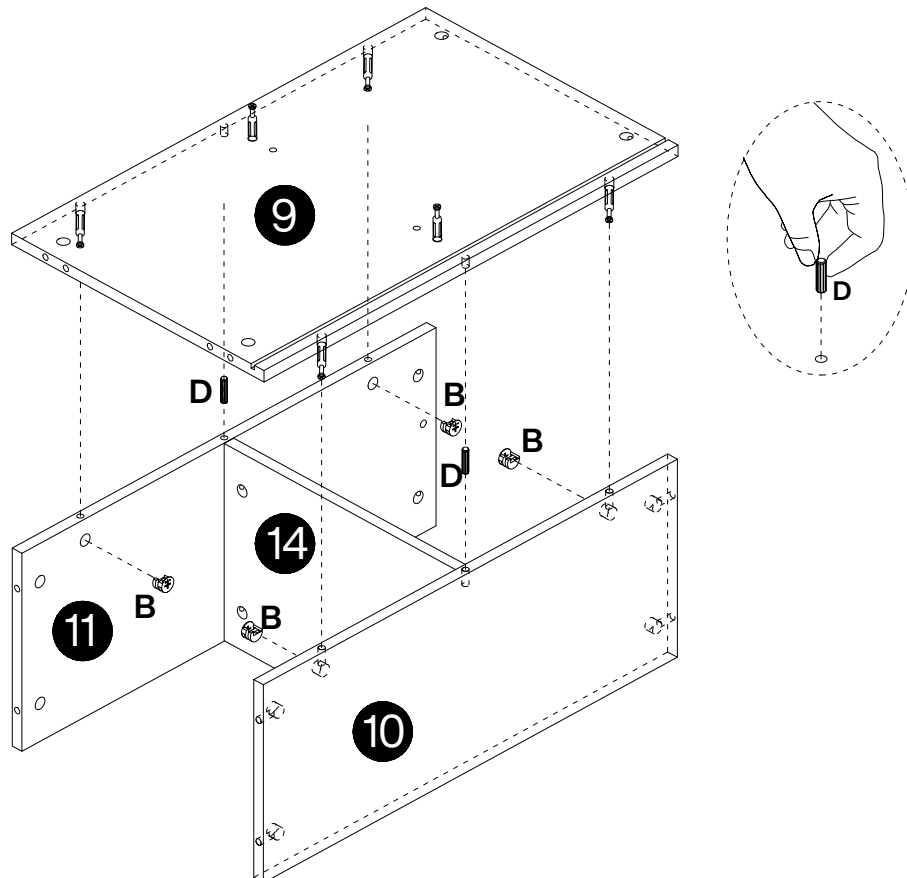

B

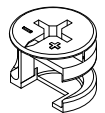

Ø15×12mm  
4 pcs

D

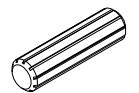

Ø8×30mm  
2 pcs

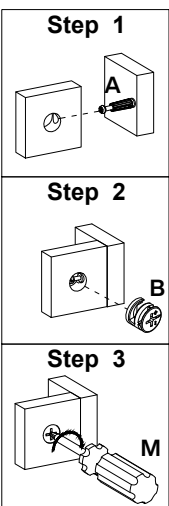



11

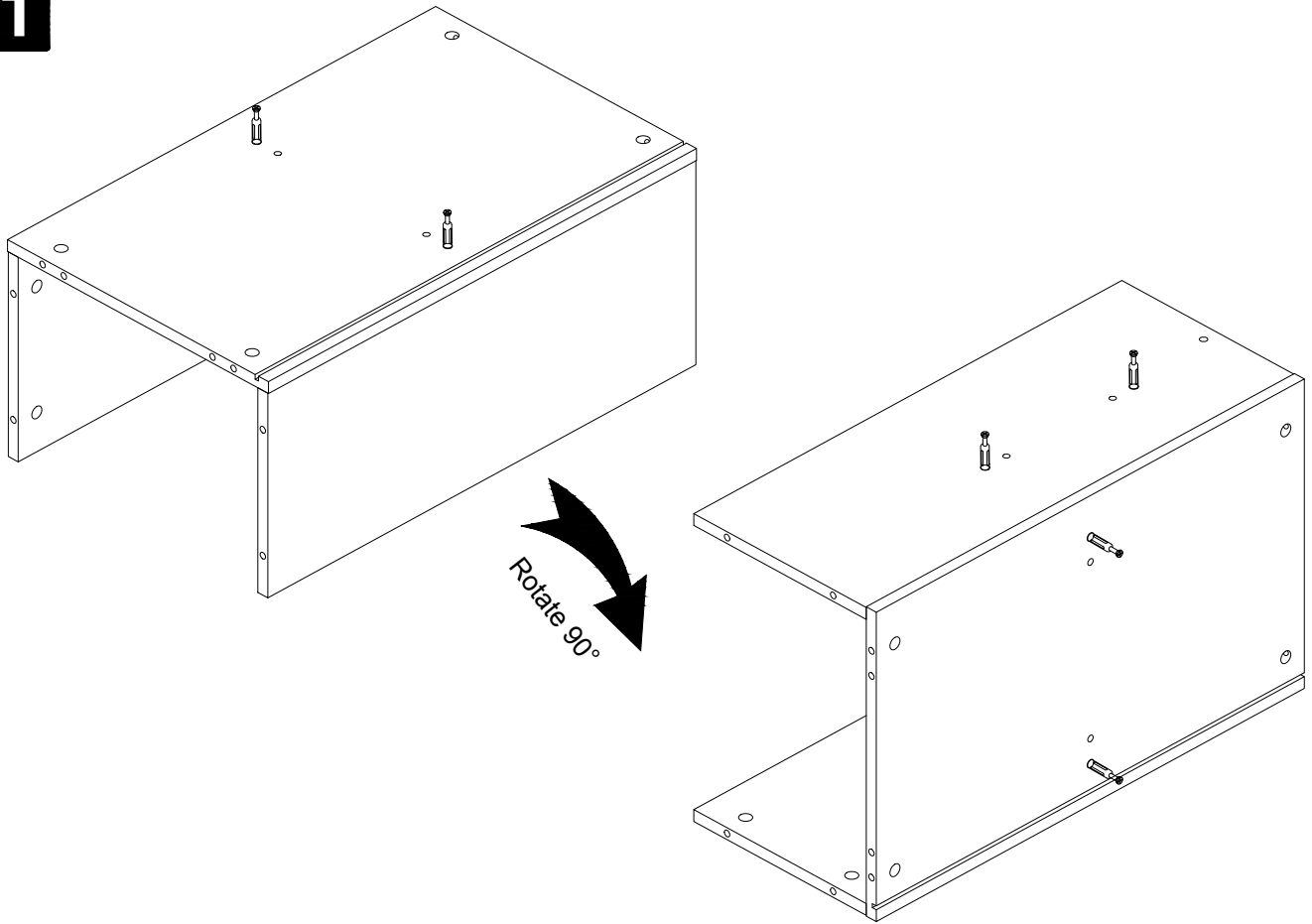

12

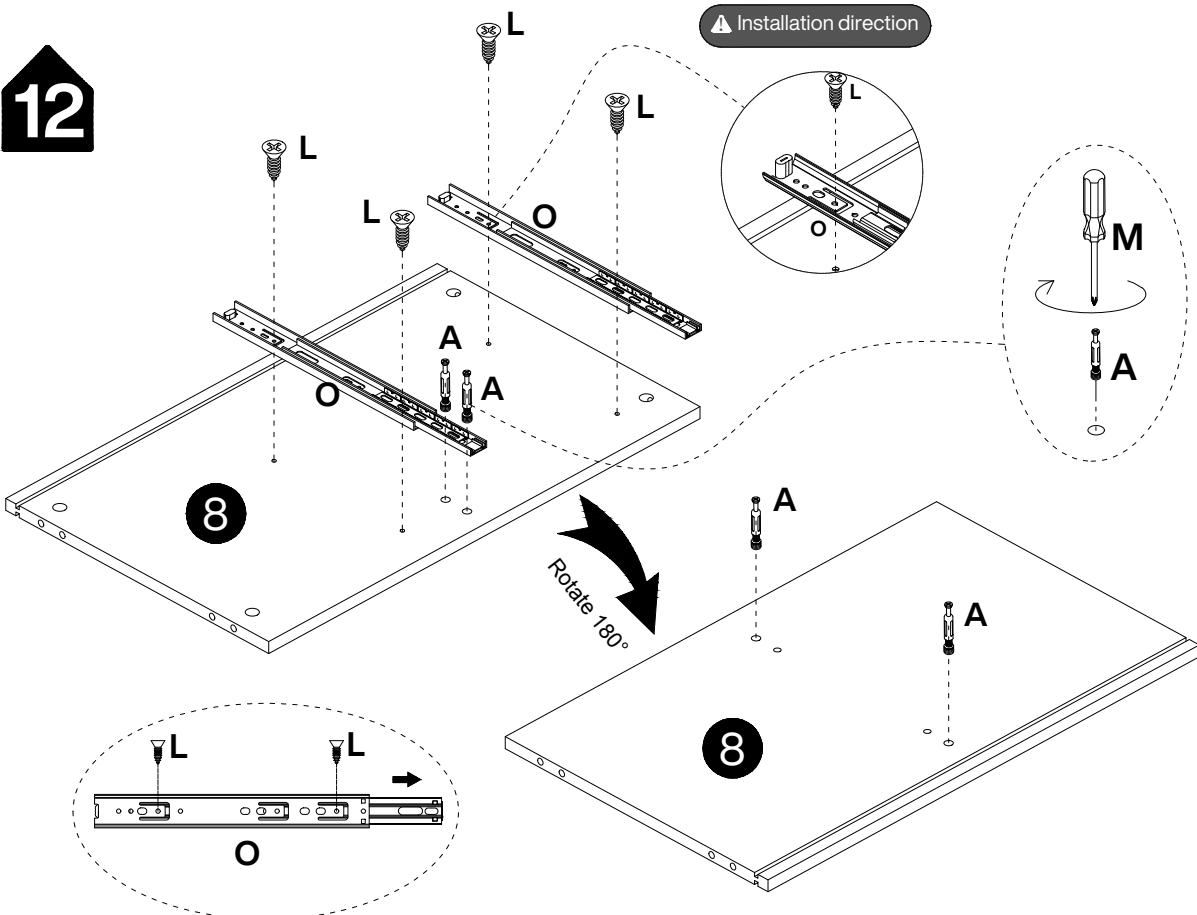

A

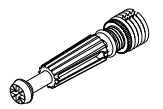

M6×40mm  
4 pcs

L

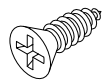

Ø3.5×14mm  
4 pcs

O



L300mm  
1sets



13

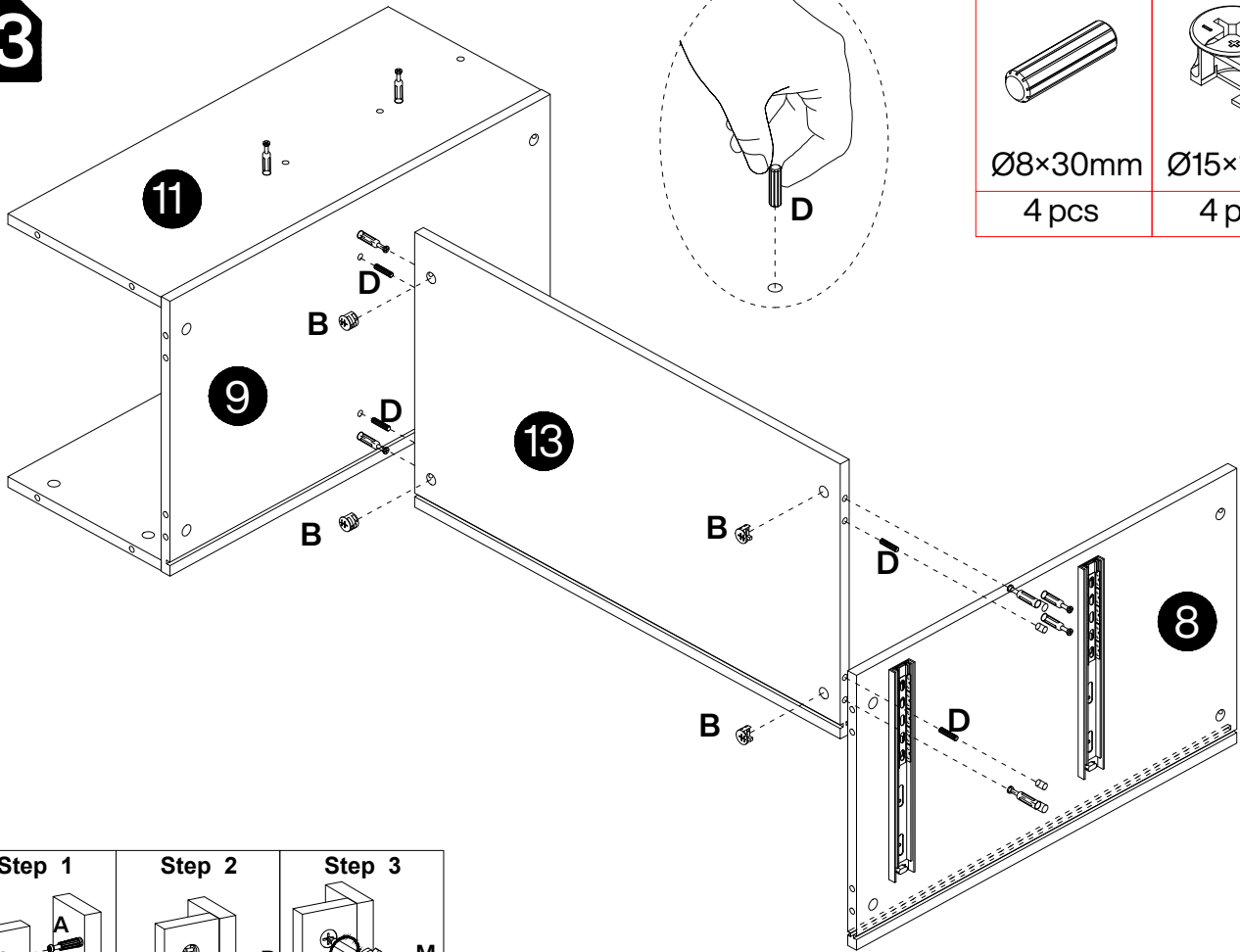

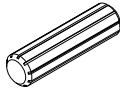
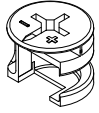
D	B
	
Ø8×30mm	Ø15×12mm
4 pcs	4 pcs

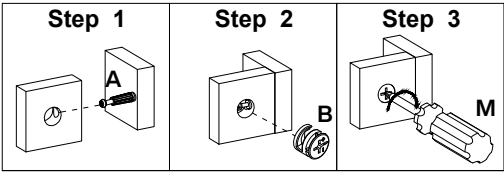

14

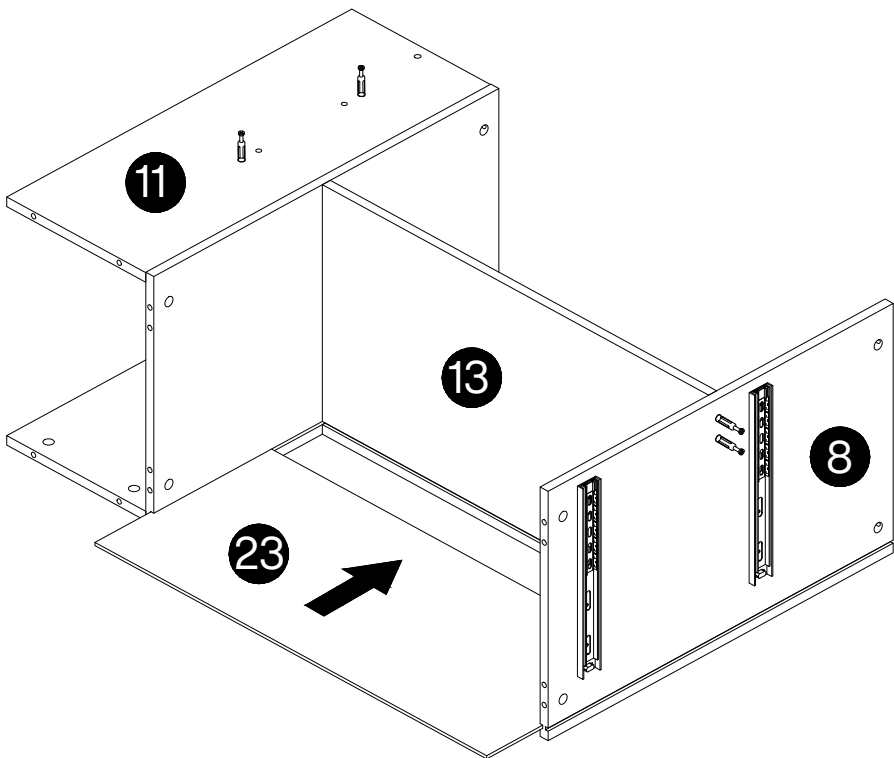



15

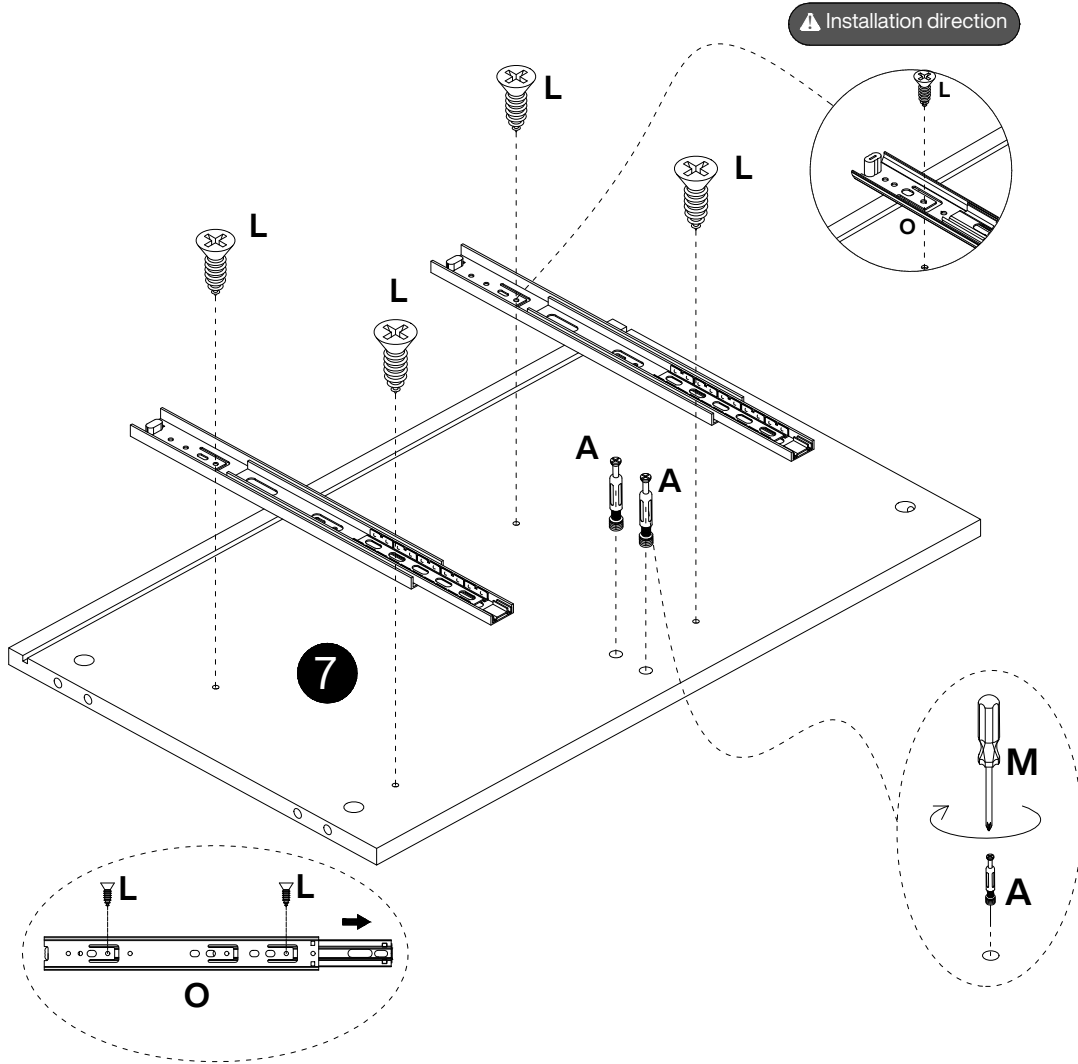

A

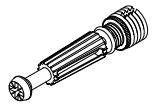

M6×40mm

2 pcs

L

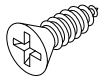

Ø3.5×14mm

4 pcs

O



L300mm

1sets

16

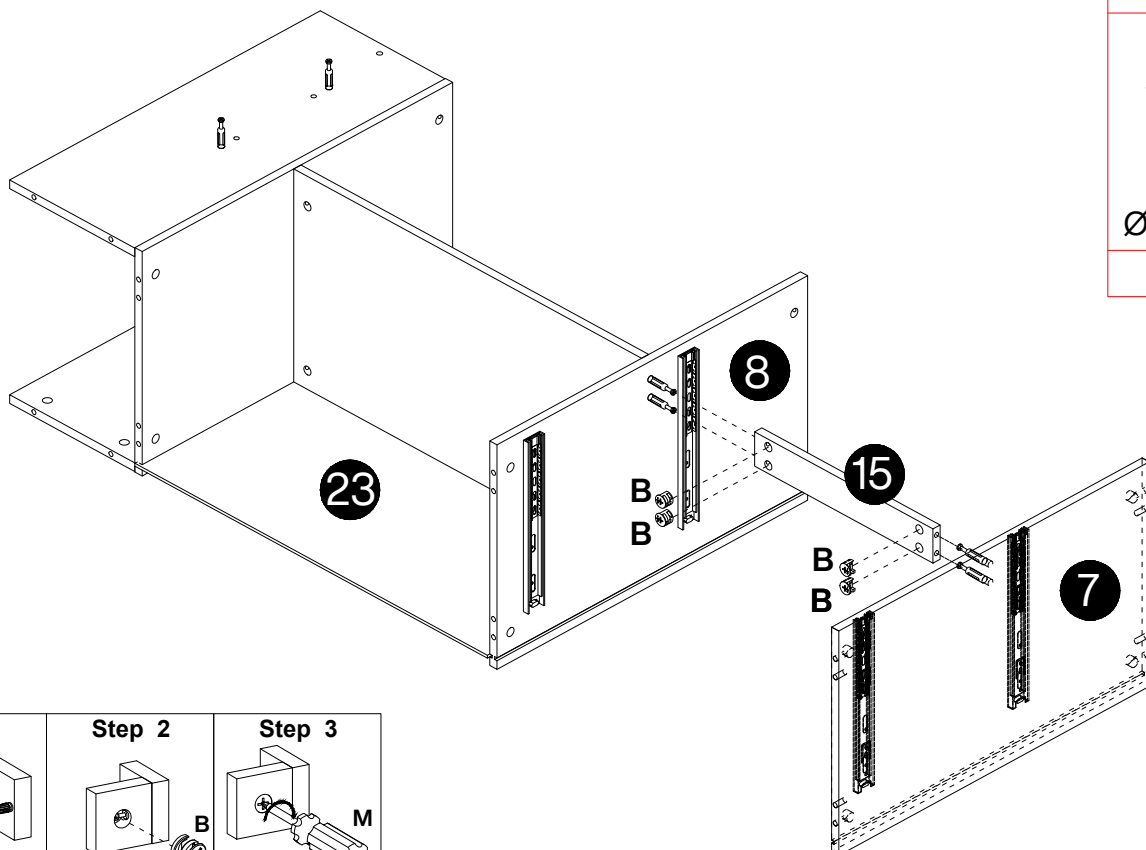

B

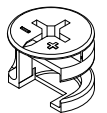

Ø15×12mm

4 pcs

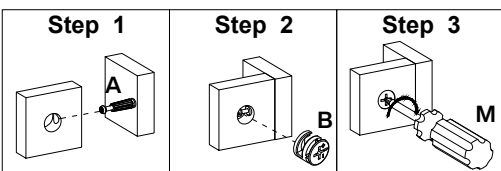

Step 1

Step 2

Step 3



17

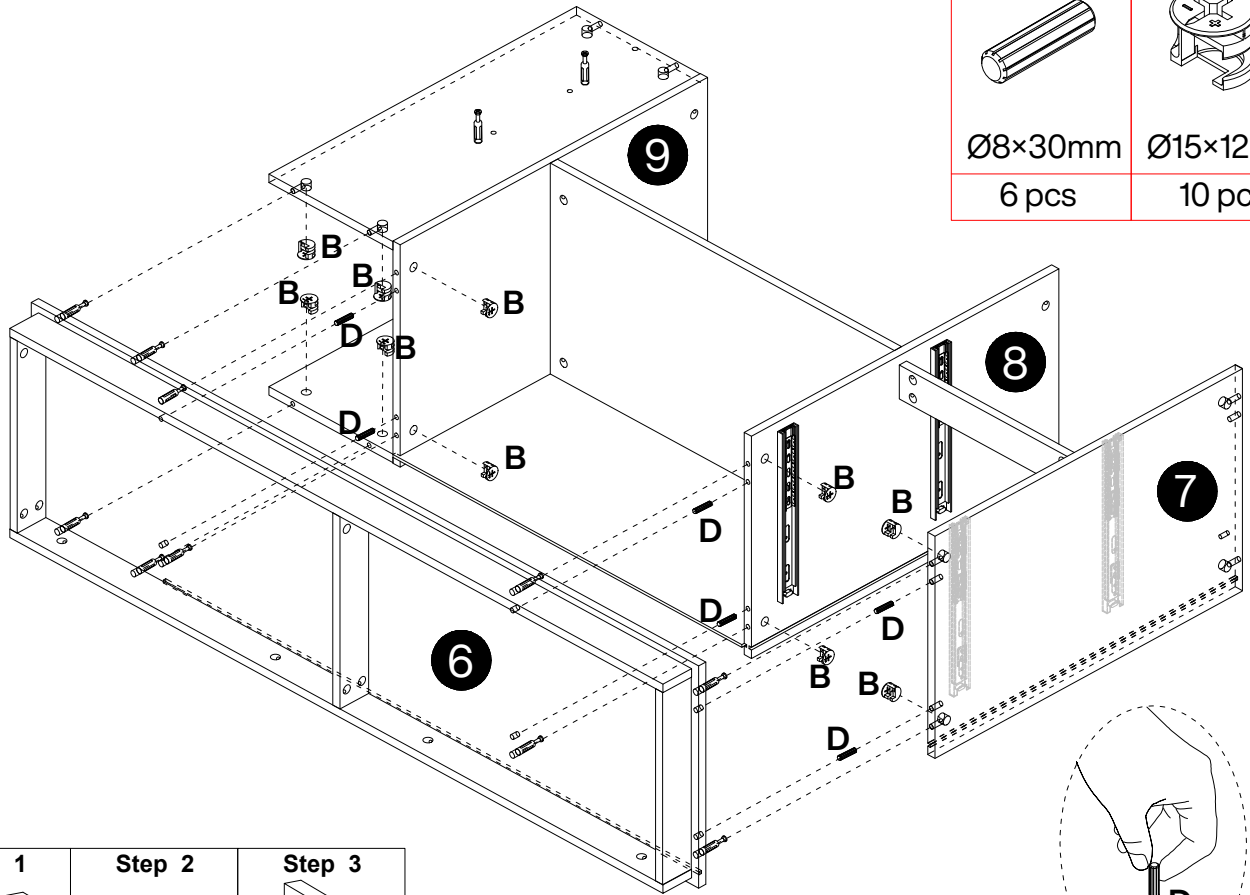

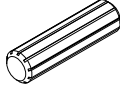
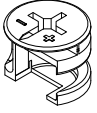
D	B
	
Ø8×30mm	Ø15×12mm
6 pcs	10 pcs

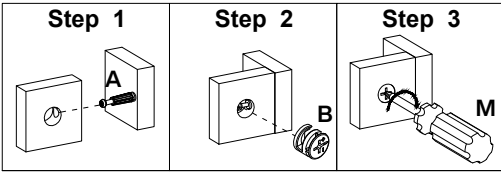

18

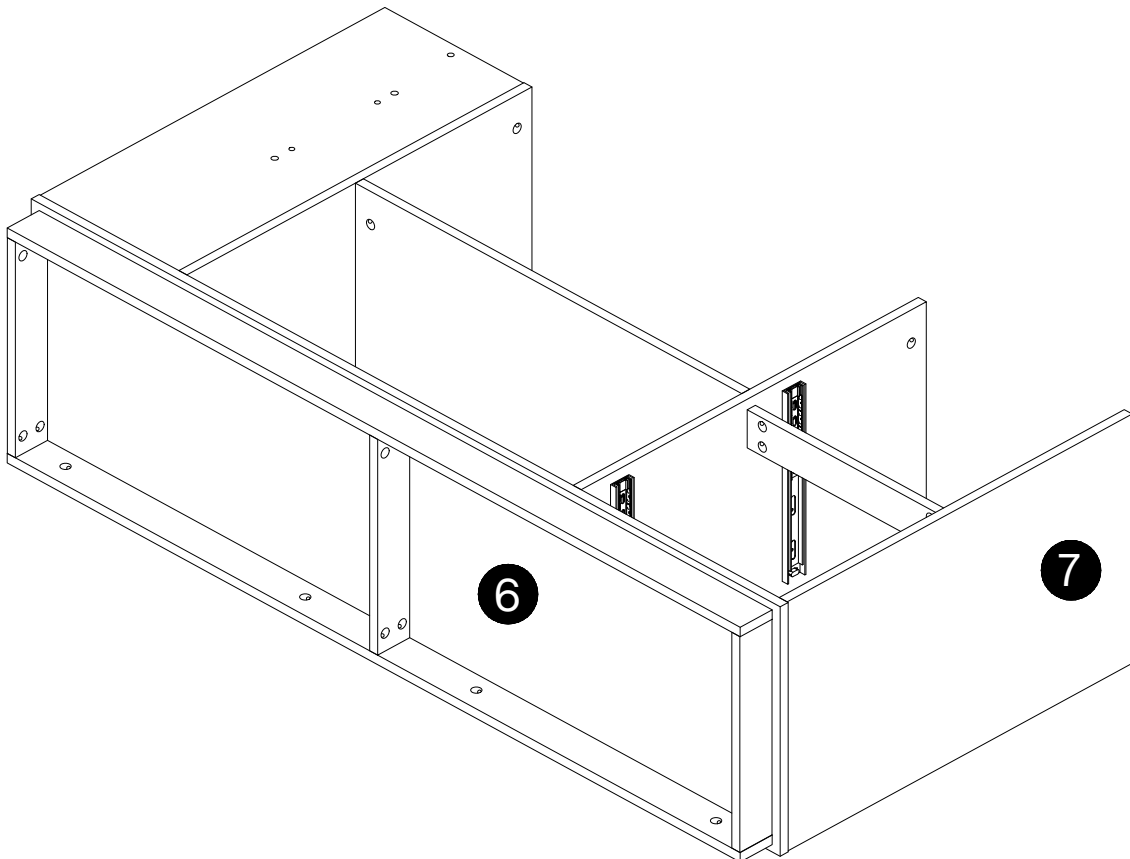



19

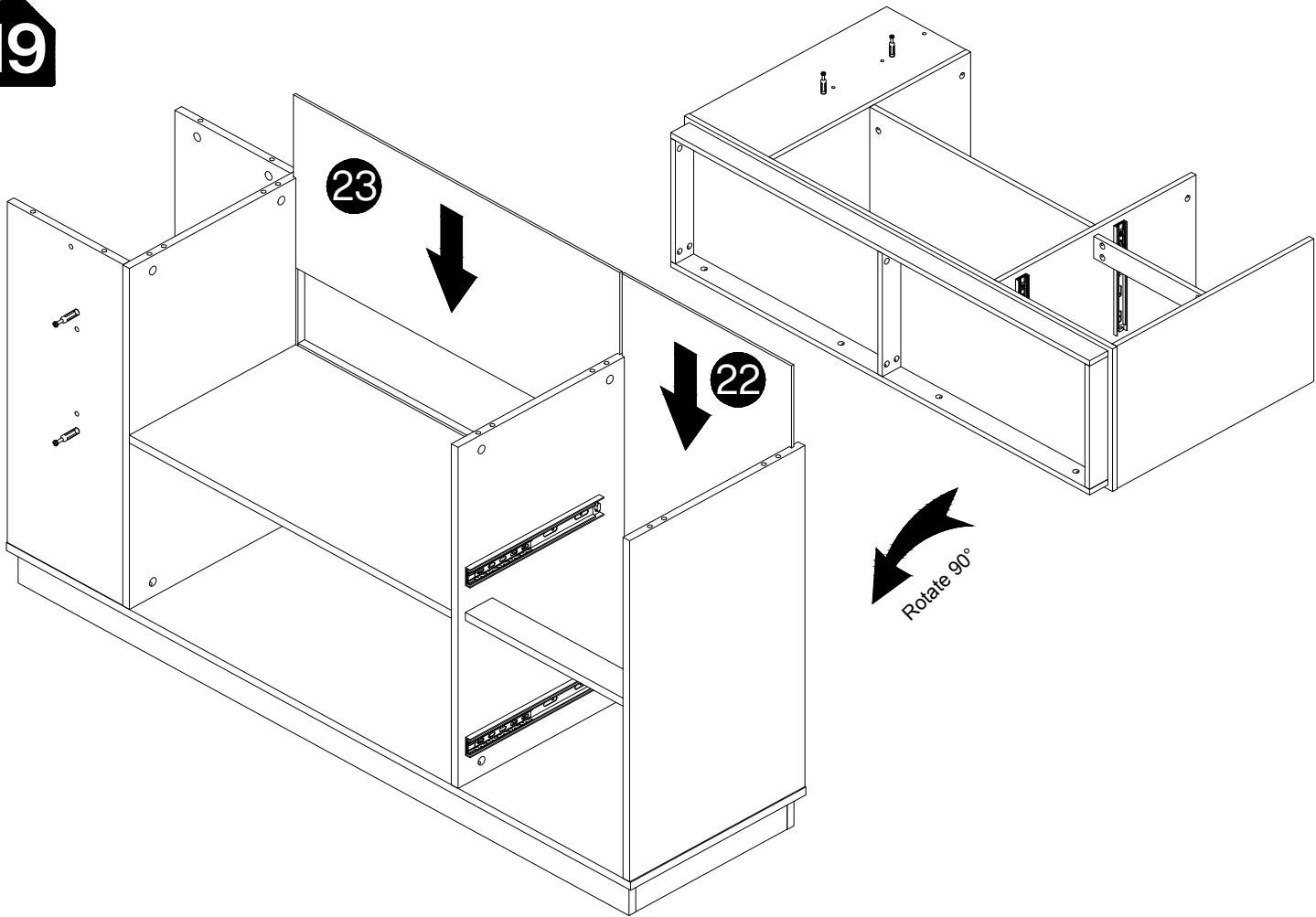

20

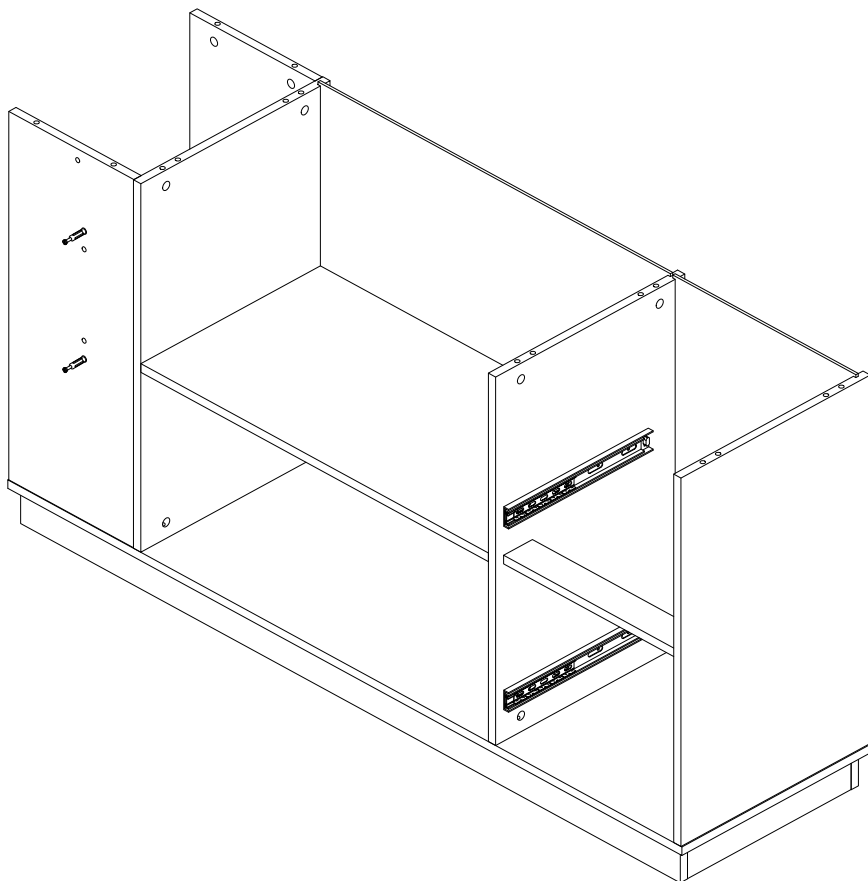



21

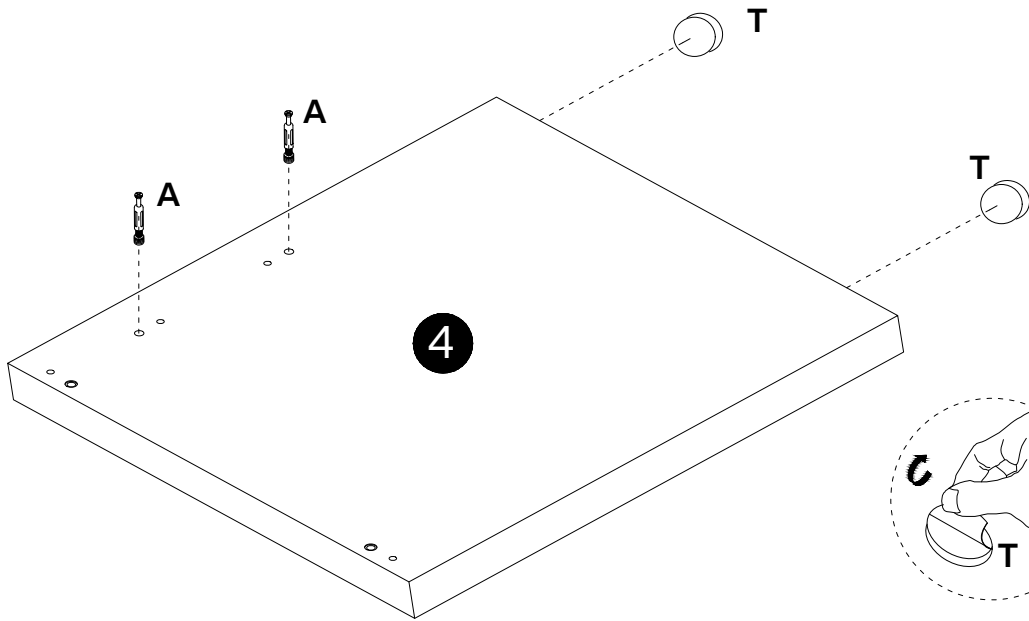

<b>A</b>

M6×40mm 2 pcs
<b>T</b>

Ø25×2mm 2 pcs

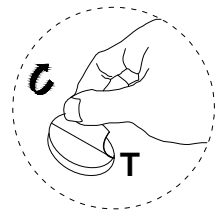

To prevent the table from scratching the floor, please peel off the tape on the #T and tape them to the corners of the table before use.

22

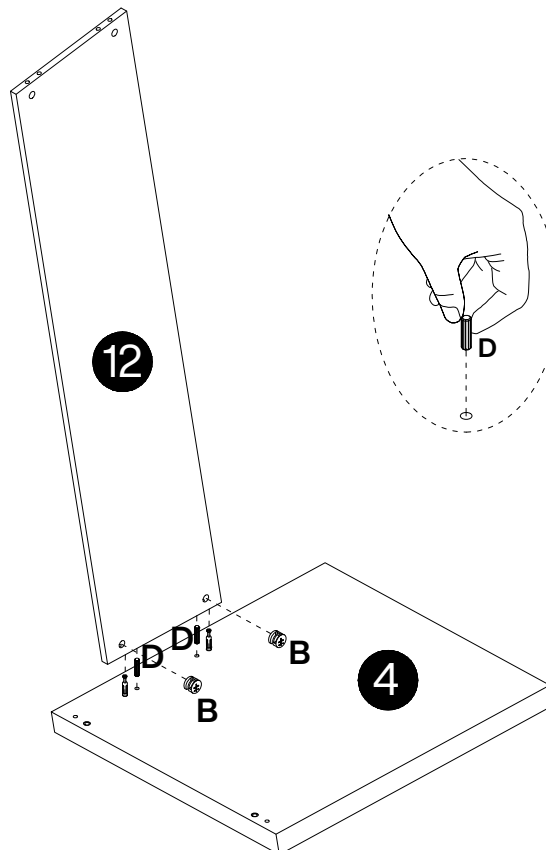

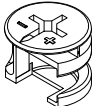
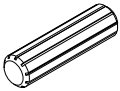
<b>B</b>

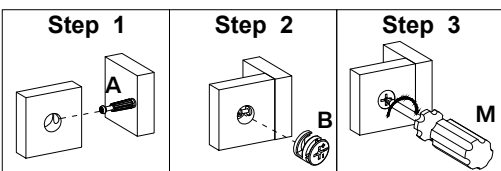
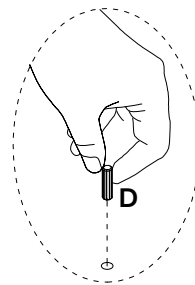
Ø15×12mm 2 pcs
<b>D</b>

Ø8×30mm 2 pcs



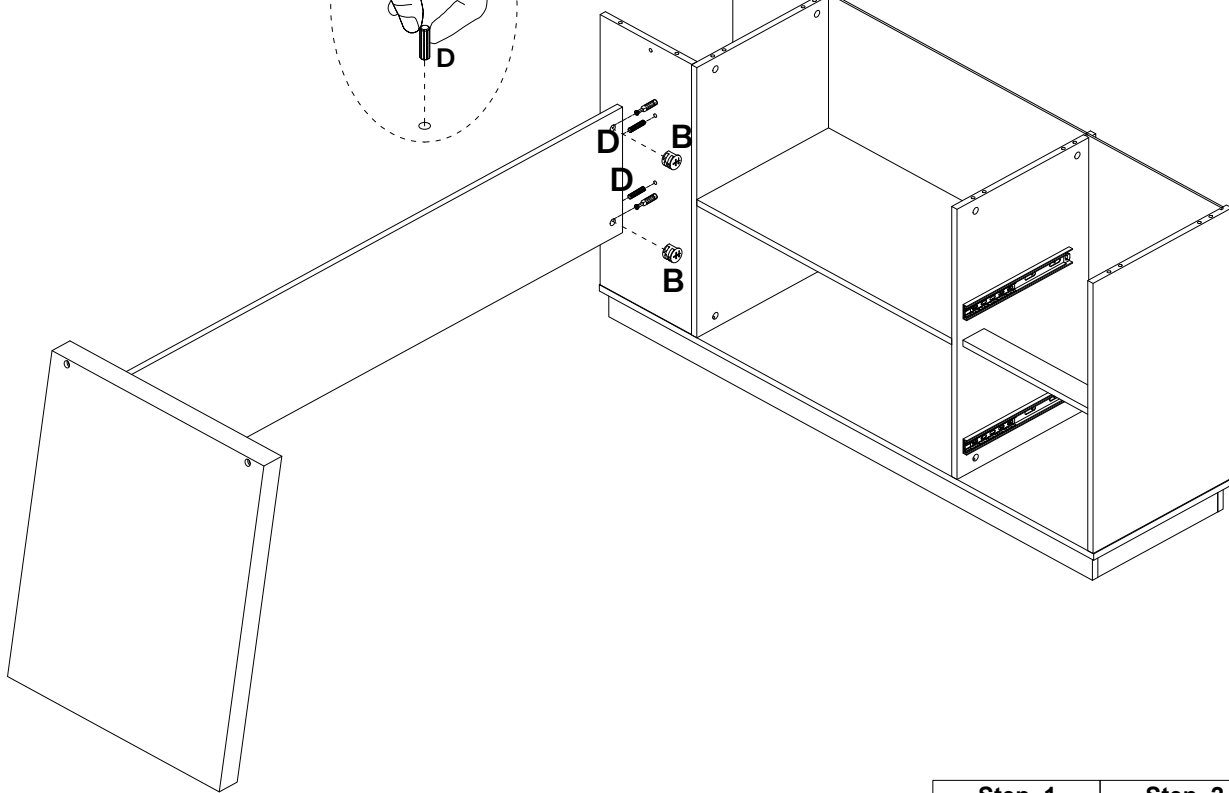
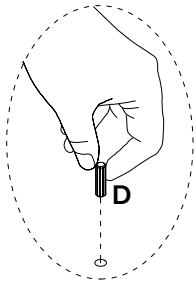

23



B

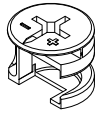

Ø15×12mm

2 pcs

D

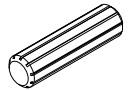

Ø8×30mm

2 pcs

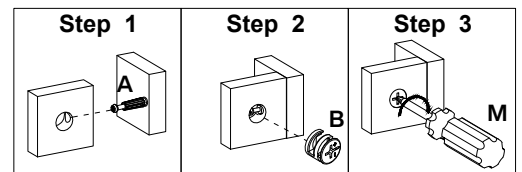

Step 1

Step 2

Step 3

24

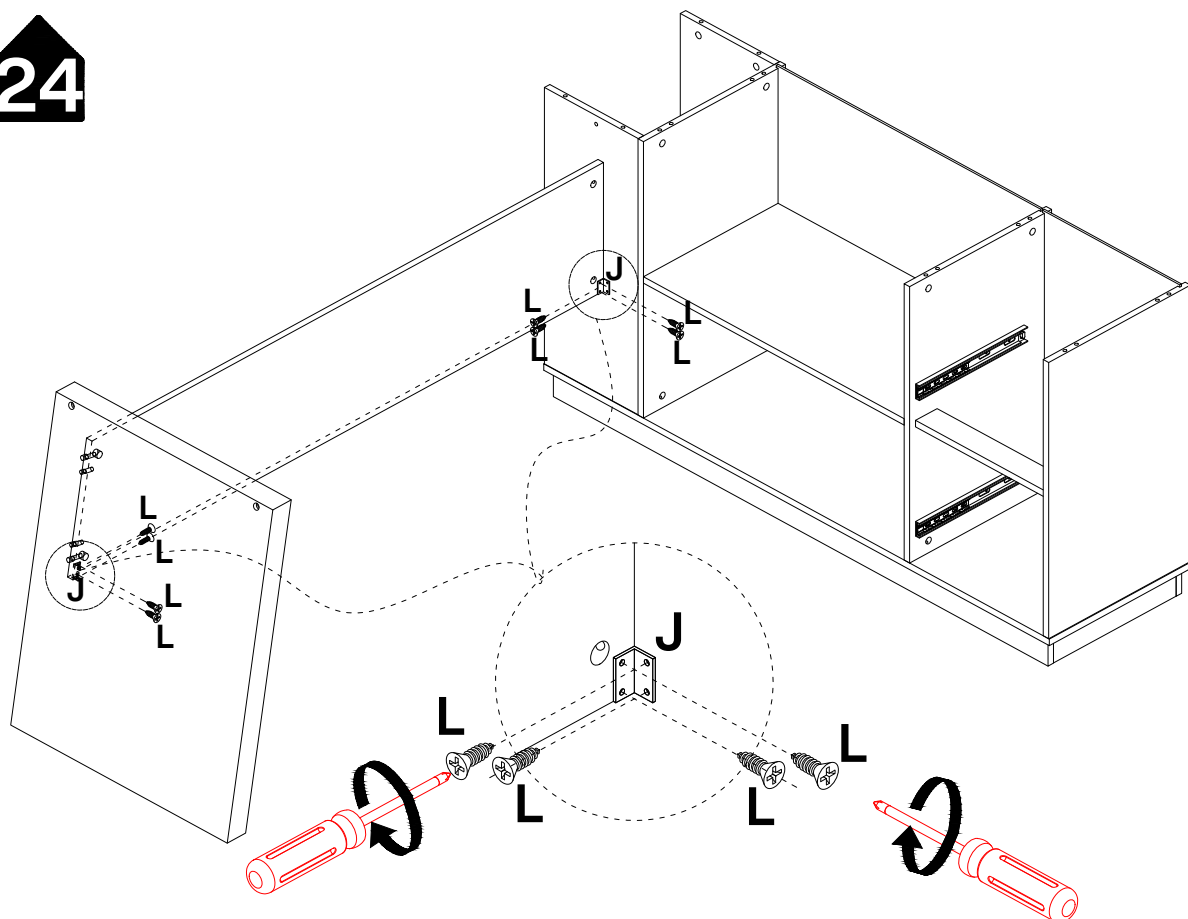

J

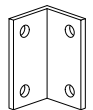

2 pcs

L

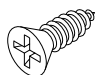

Ø3.5×14mm

8 pcs



25

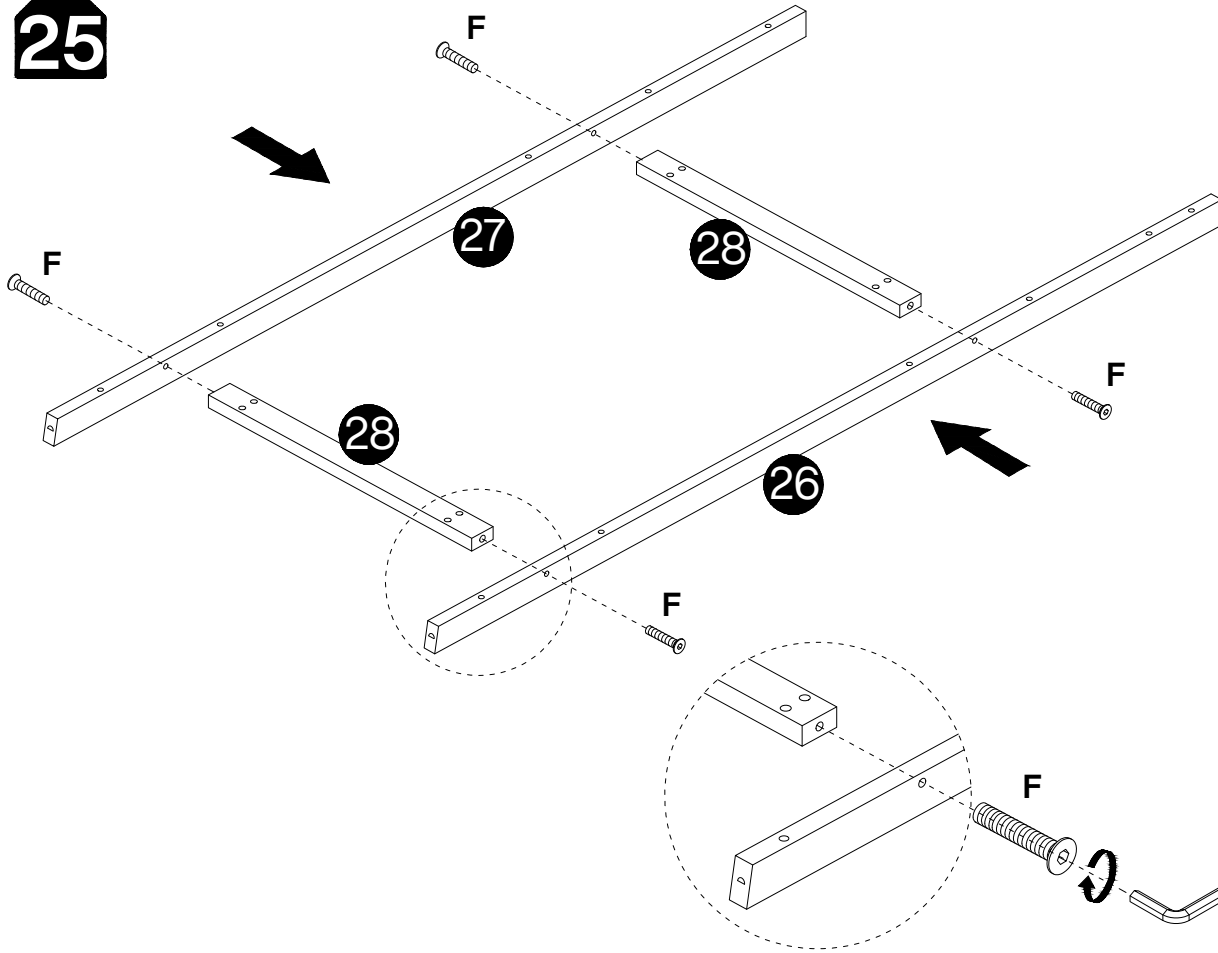

F

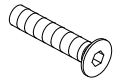

Ø6×35mm

4 pcs

I



M3

1 pc

26

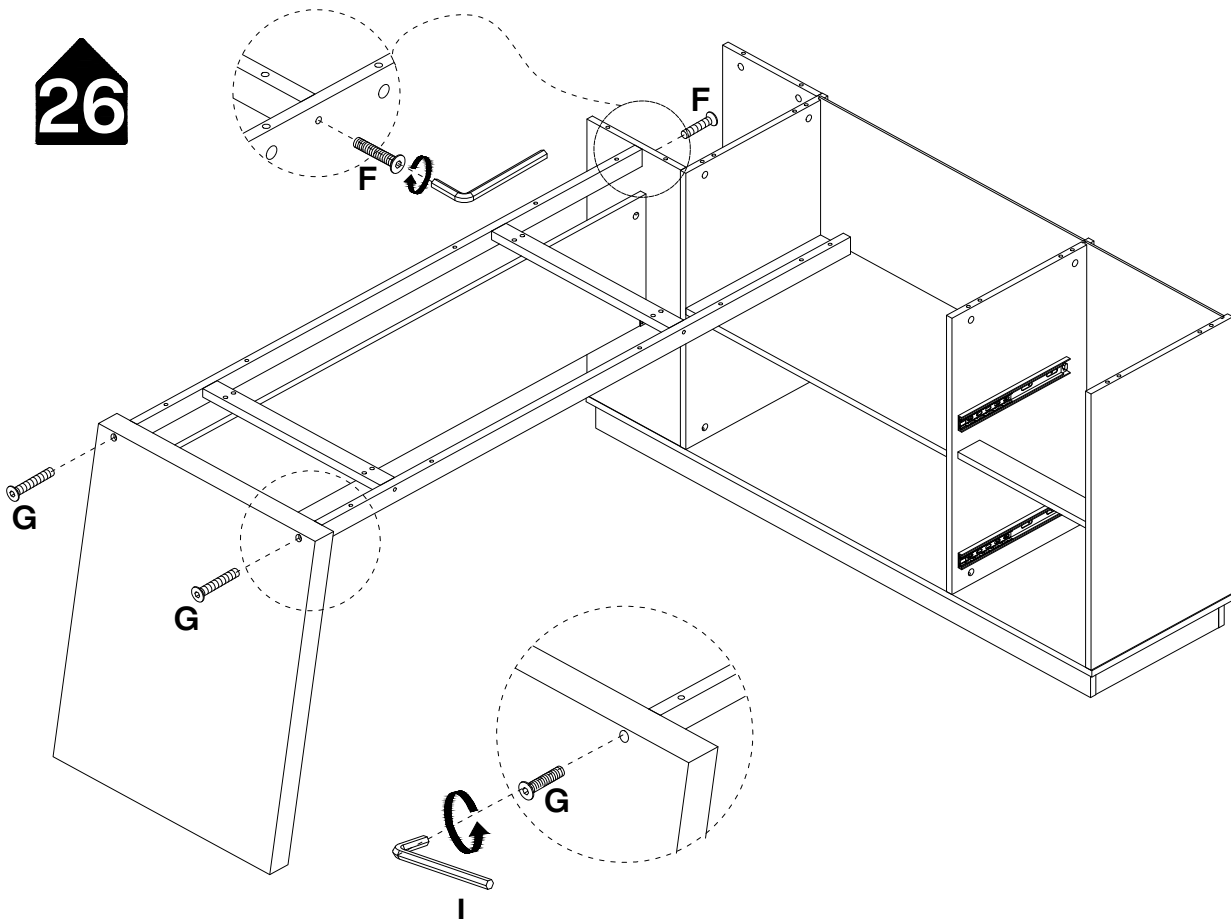

F

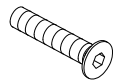

Ø6×35mm

1 pcs

G

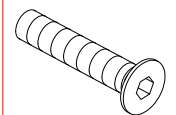

Ø6×55mm

2 pcs



27

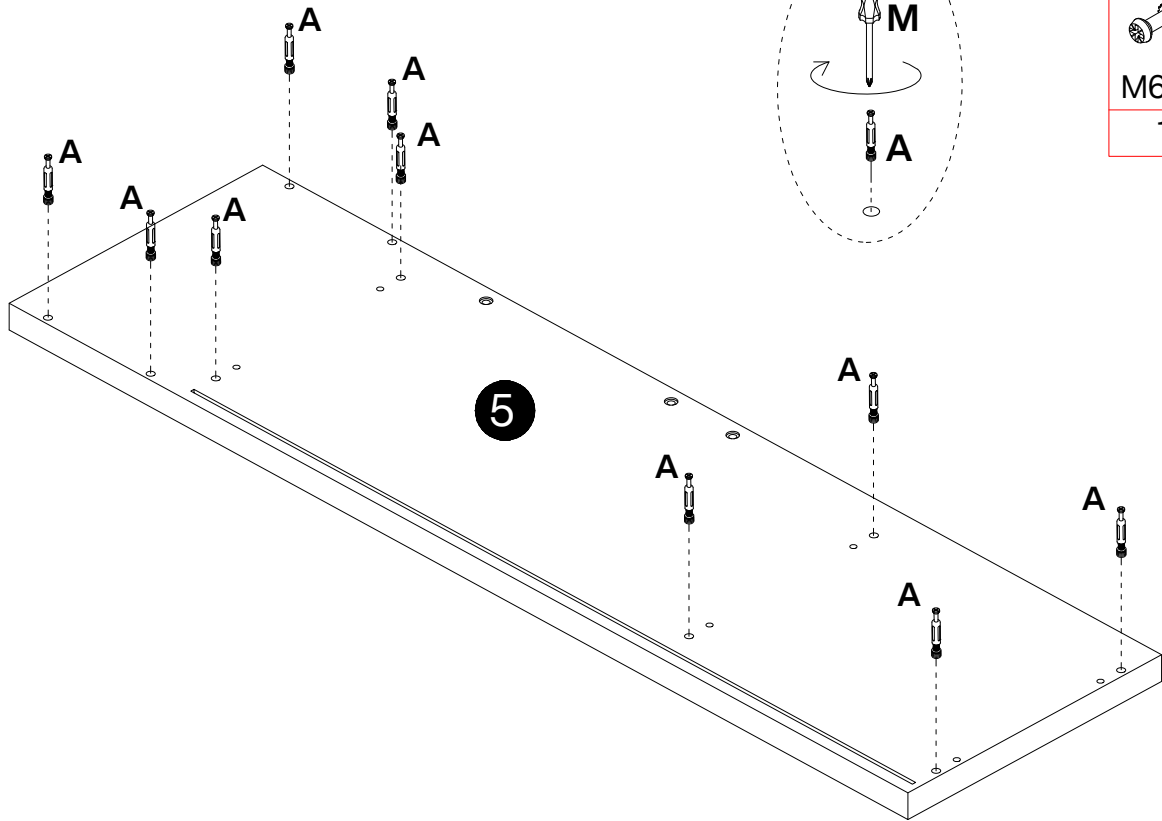

A

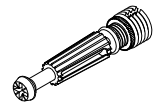

M6×40mm  
10 pcs

28

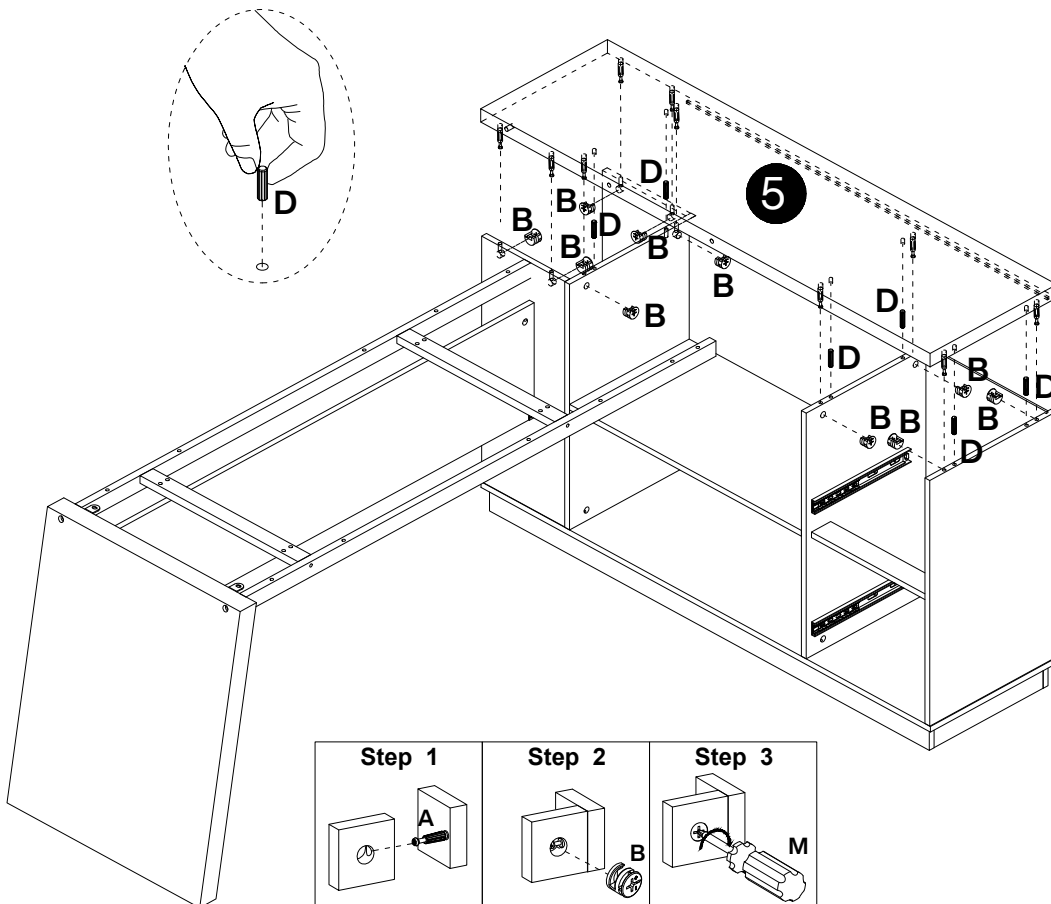

B

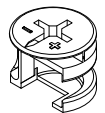

Ø15×12mm  
10 pcs

D

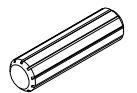

Ø8×30mm  
6 pcs

Step 1

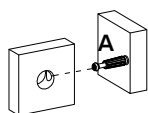

Step 2

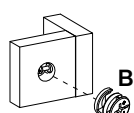

Step 3

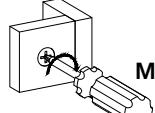



29

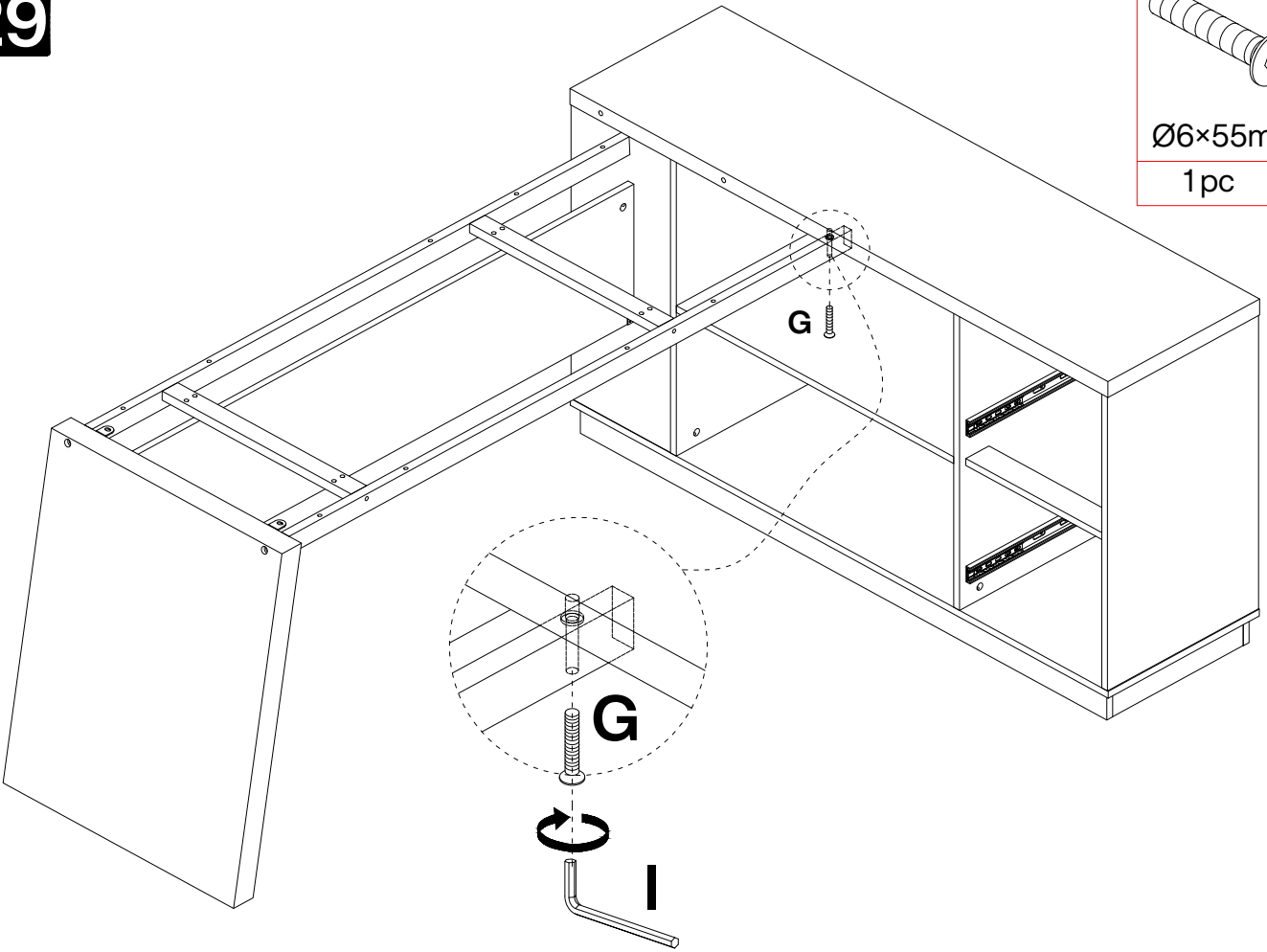

G

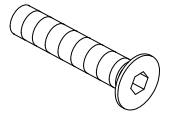

Ø6×55mm

1 pc

30

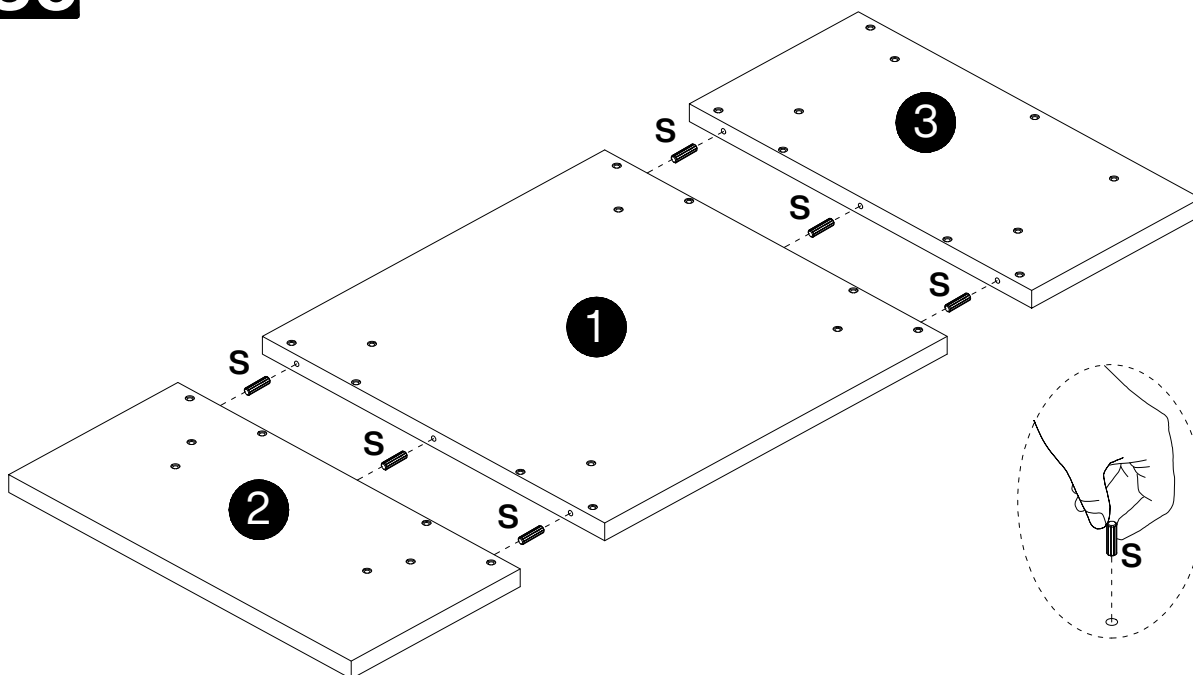

S

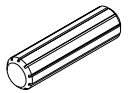

Ø10×40mm

6 pcs



31

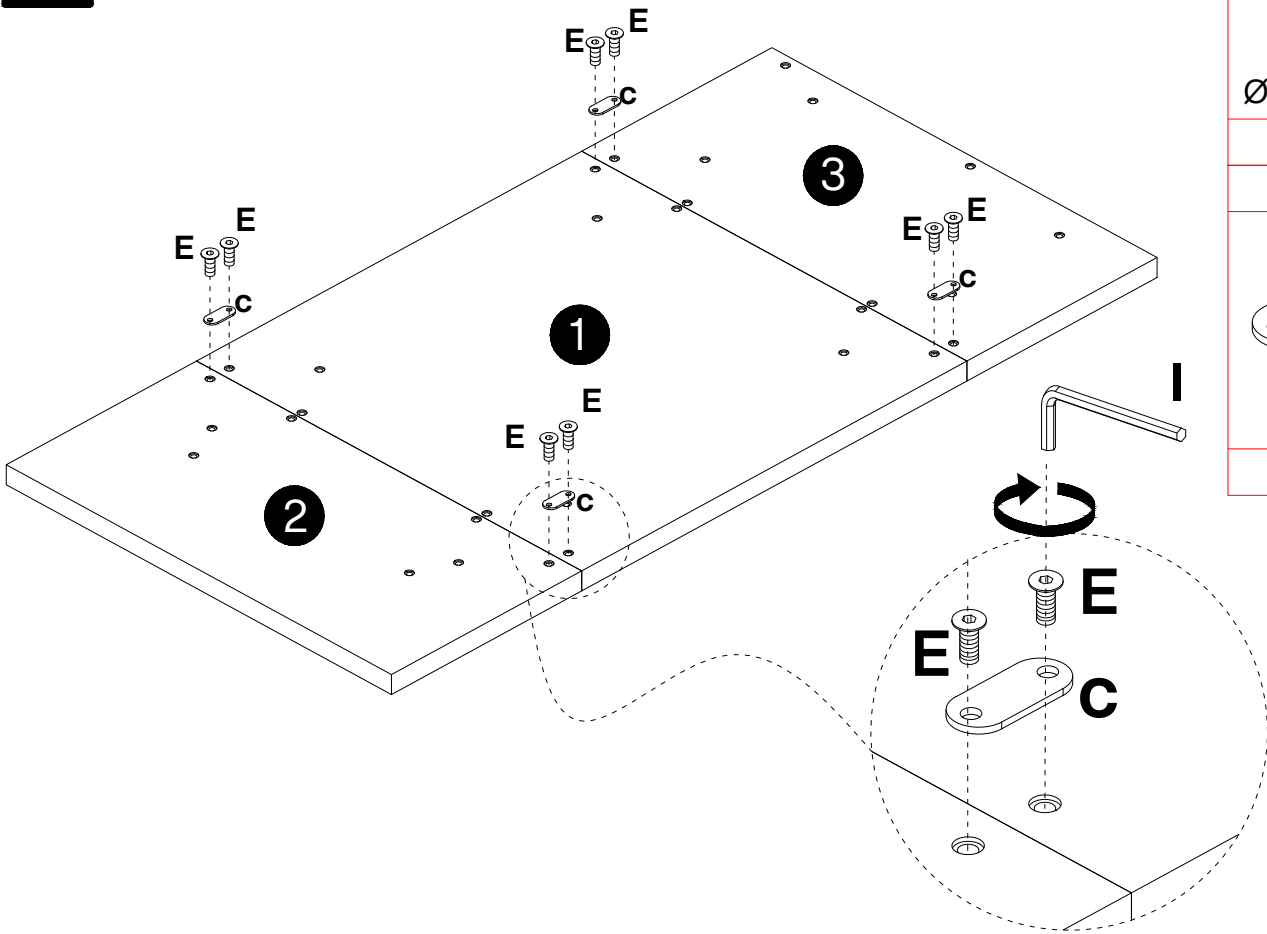

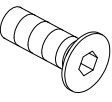
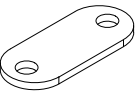
<b>E</b>

Ø6×16mm
8pcs
<b>C</b>

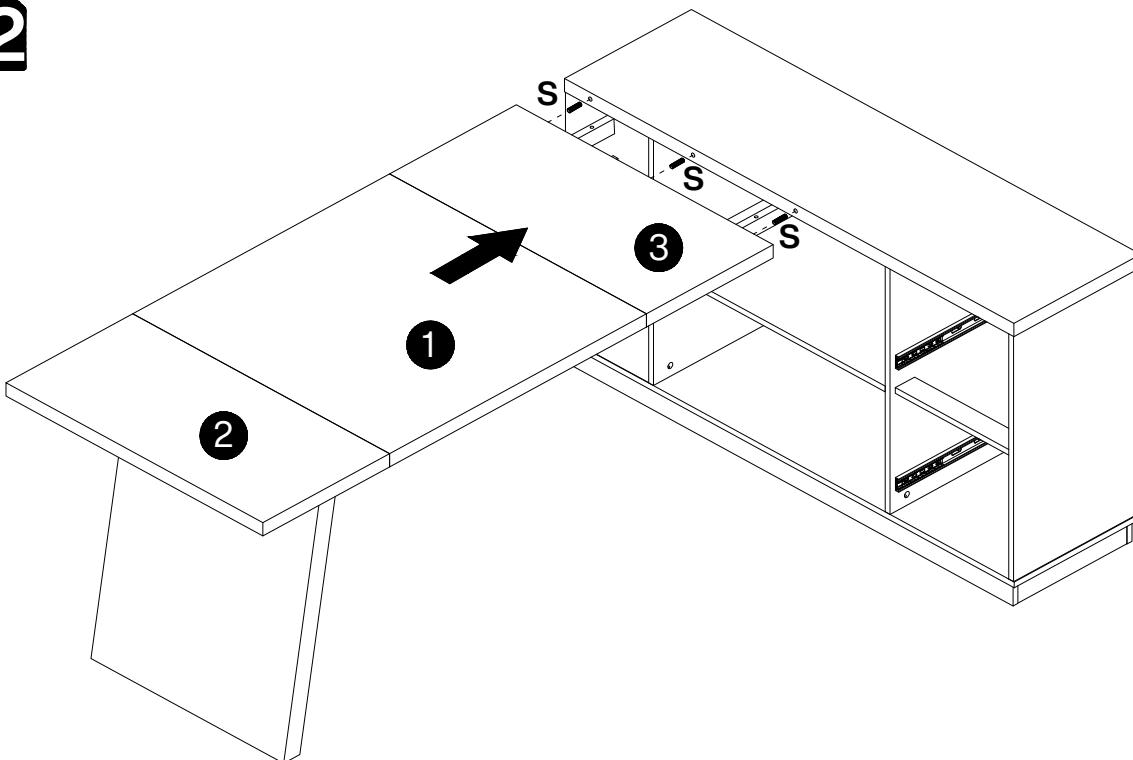
4pcs

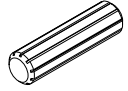
32



<b>S</b>

Ø10×40mm
3 pcs

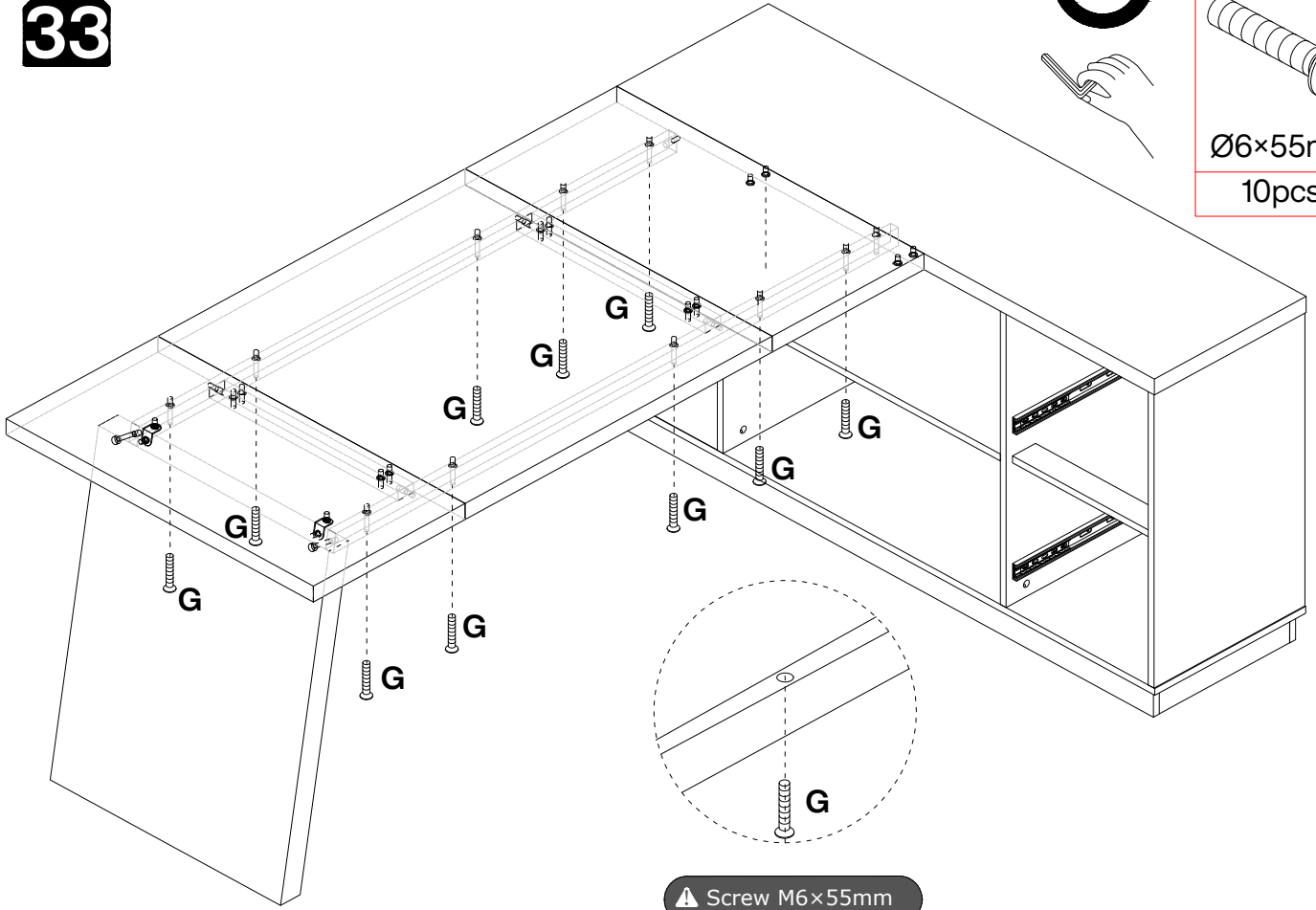

33

pre-drill 70% 

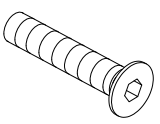

<b>G</b>

Ø6×55mm
10 pcs

 Screw M6×55mm

34

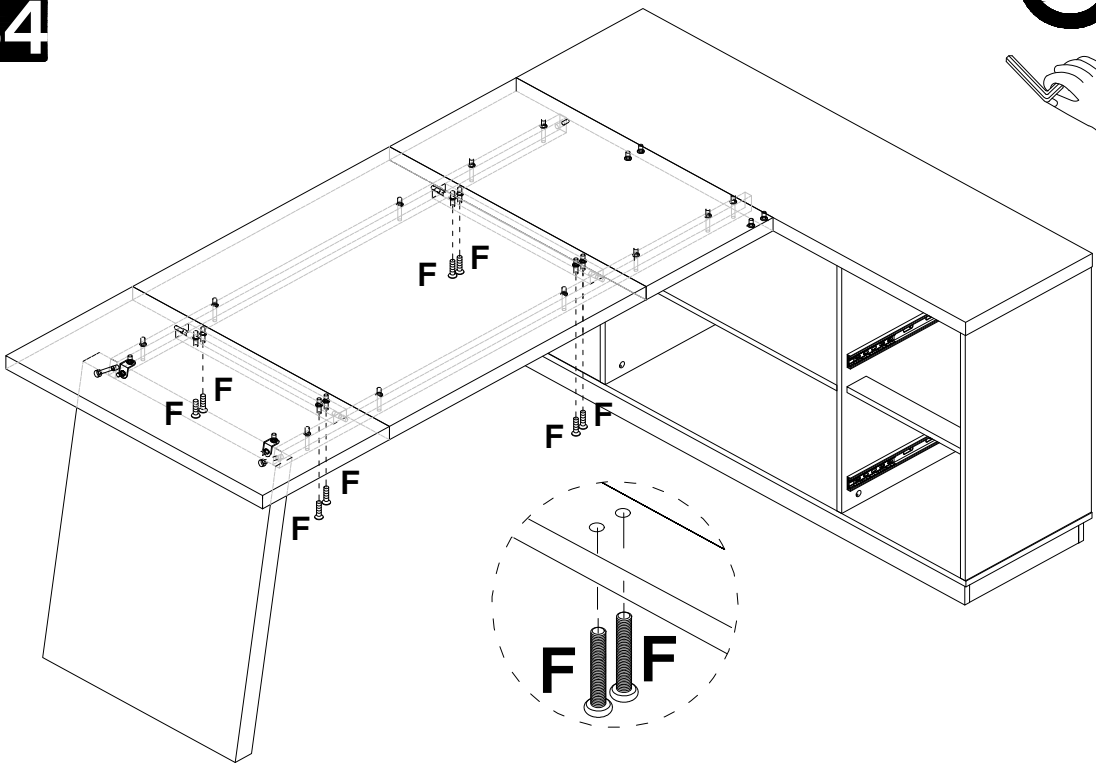
pre-drill 70% 

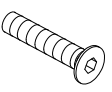

<b>F</b>

Ø6×35mm
8 pcs

 Screw M6×35mm



35

⚠ Screw M6×16mm

pre-drill 70% 

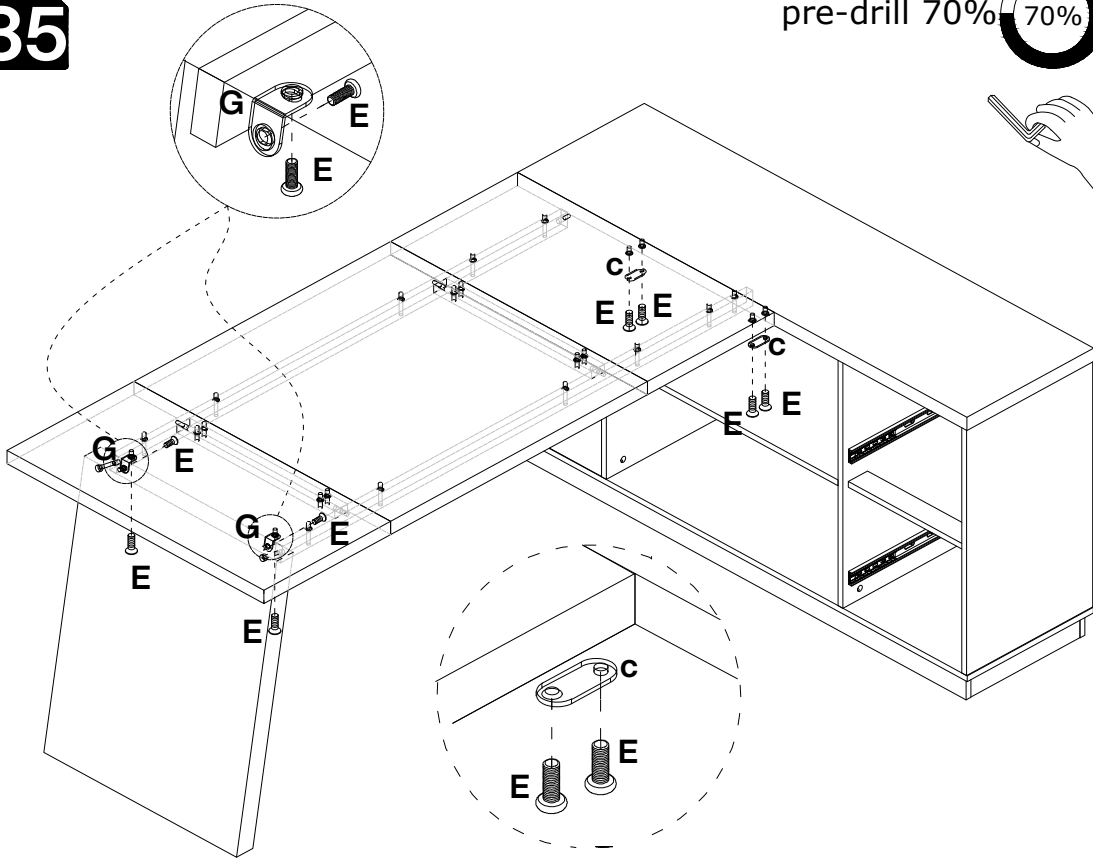

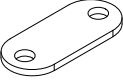
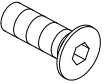
<b>G</b>

2pcs
<b>C</b>

2pcs
<b>E</b>

Ø6×16mm
8pcs

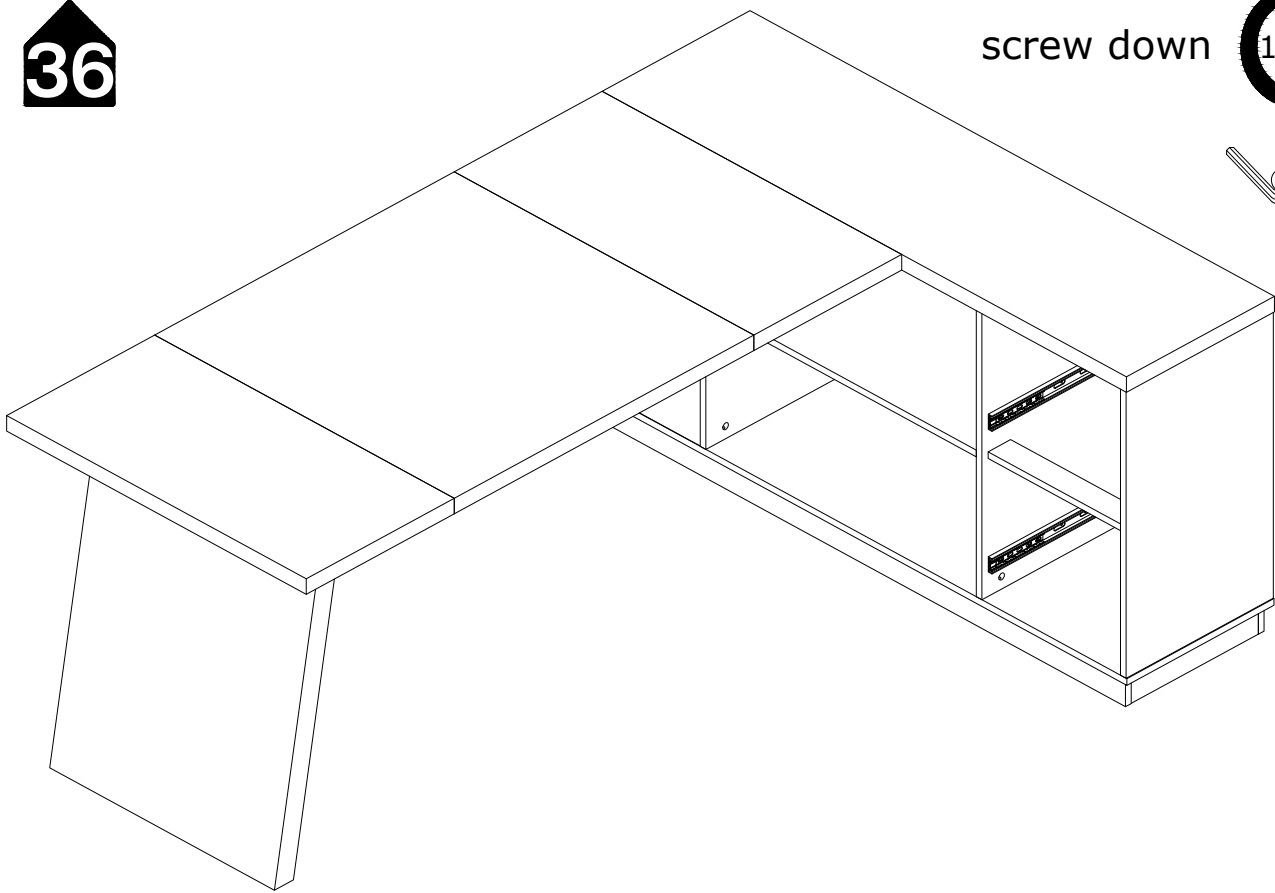
⚠ Screw M6×16mm

36

screw down 





37

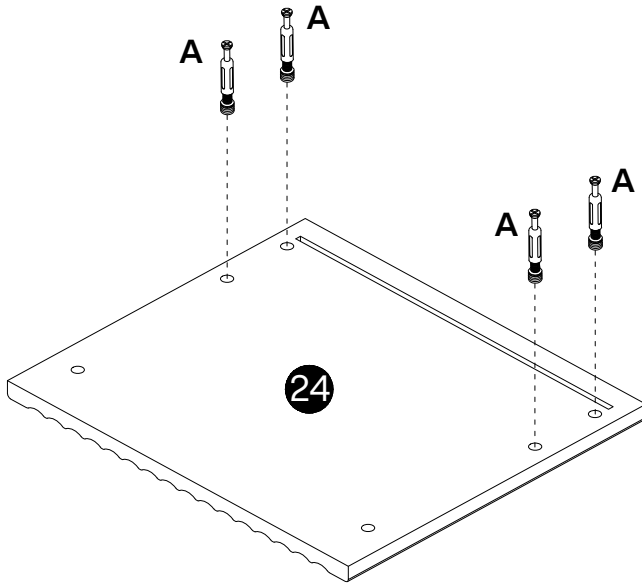

A

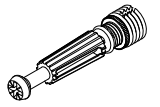

M6×40mm

8 pcs

x 2

38

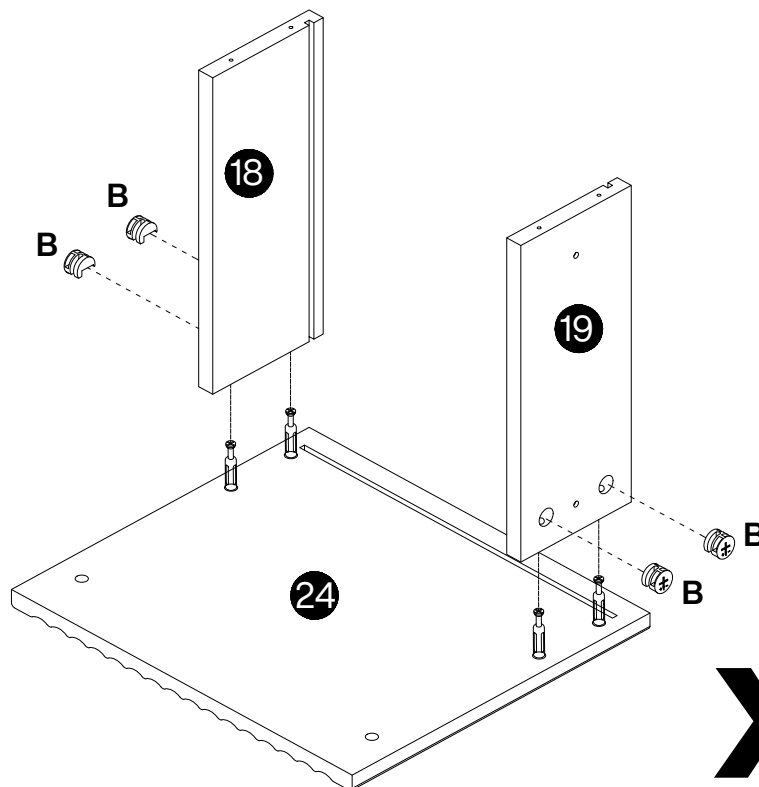

B

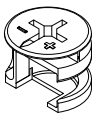

Ø15×12mm

8 pcs

x 2

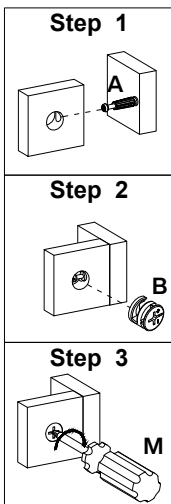



39

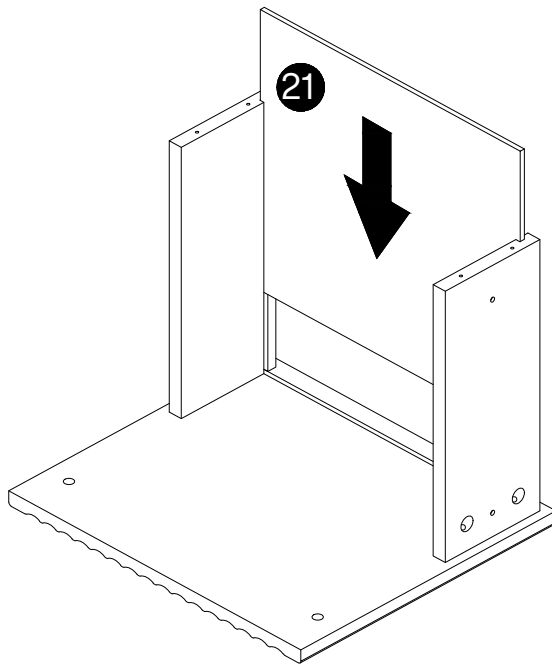

**x 2**

40

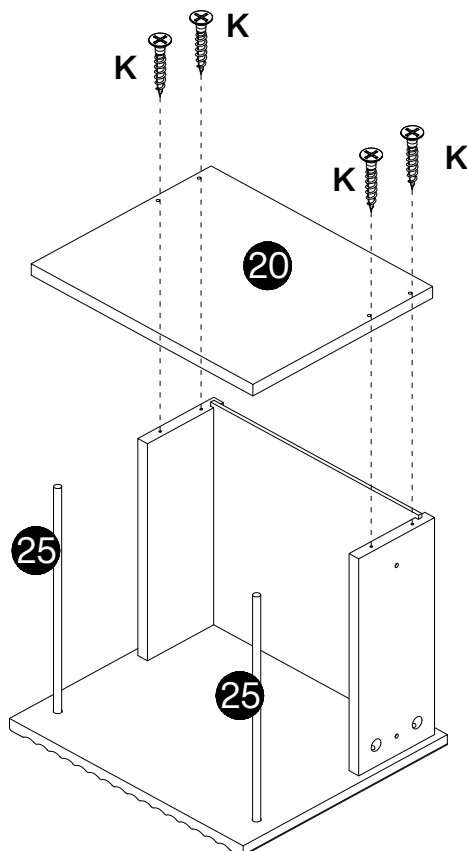

**x 2**

K

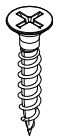

Ø3.5×35mm

8 pcs



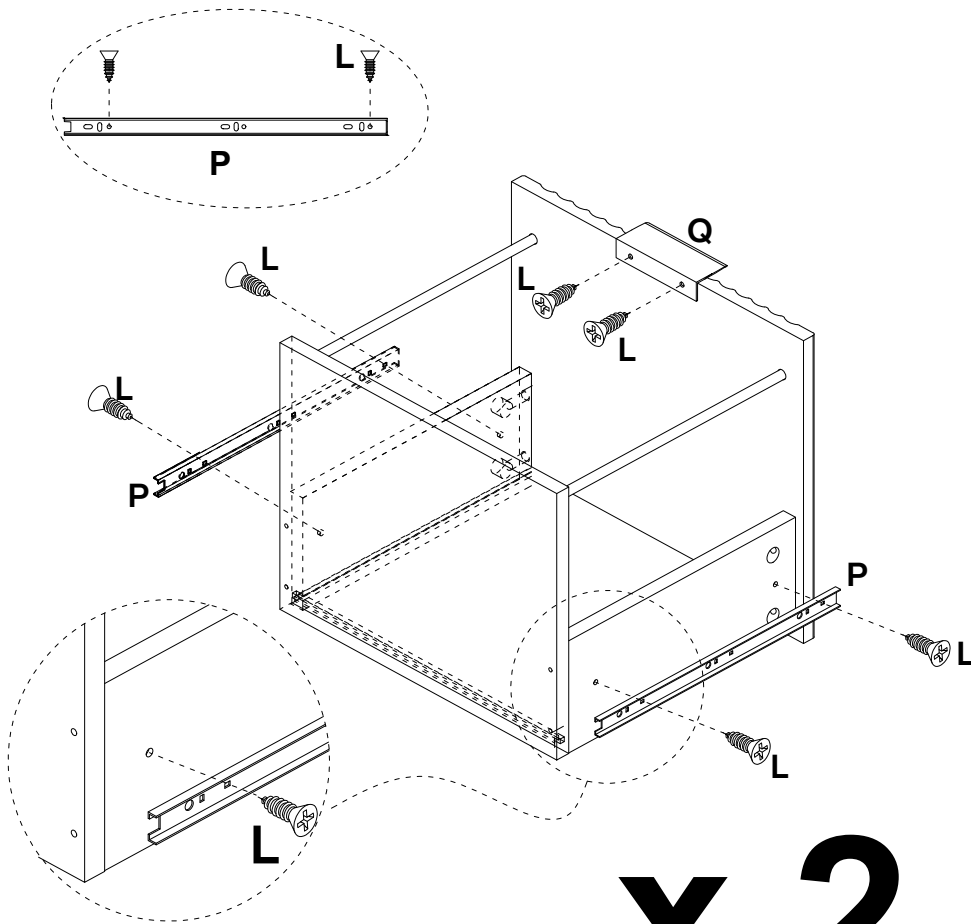

41

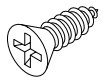
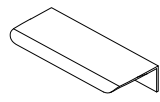

⚠ Installation direction

**X 2**

<b>L</b>

Ø3.5×14mm 12 pcs
<b>Q</b>

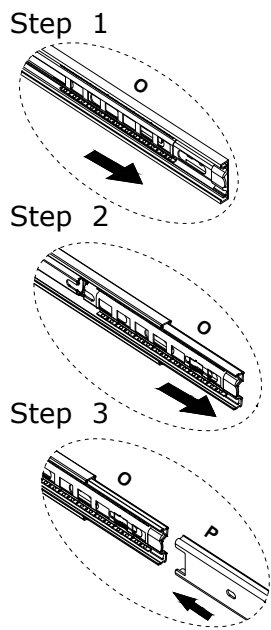
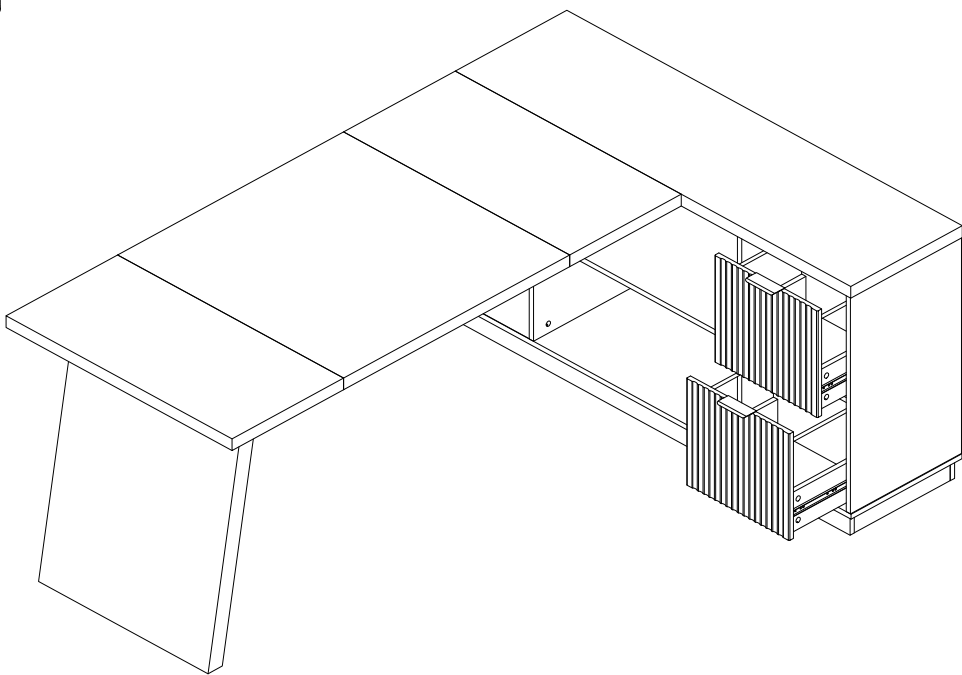
2 pcs
<b>P</b>

L300mm 2sets

42



Before installation, slide the inner iron pieces of #O to the outermost side. Then align it with #P and gently push it inward to complete the slide installation.

**Thank you for your support!**

