

# ASSEMBLY INSTRUCTIONS

## FULL/QUEEN







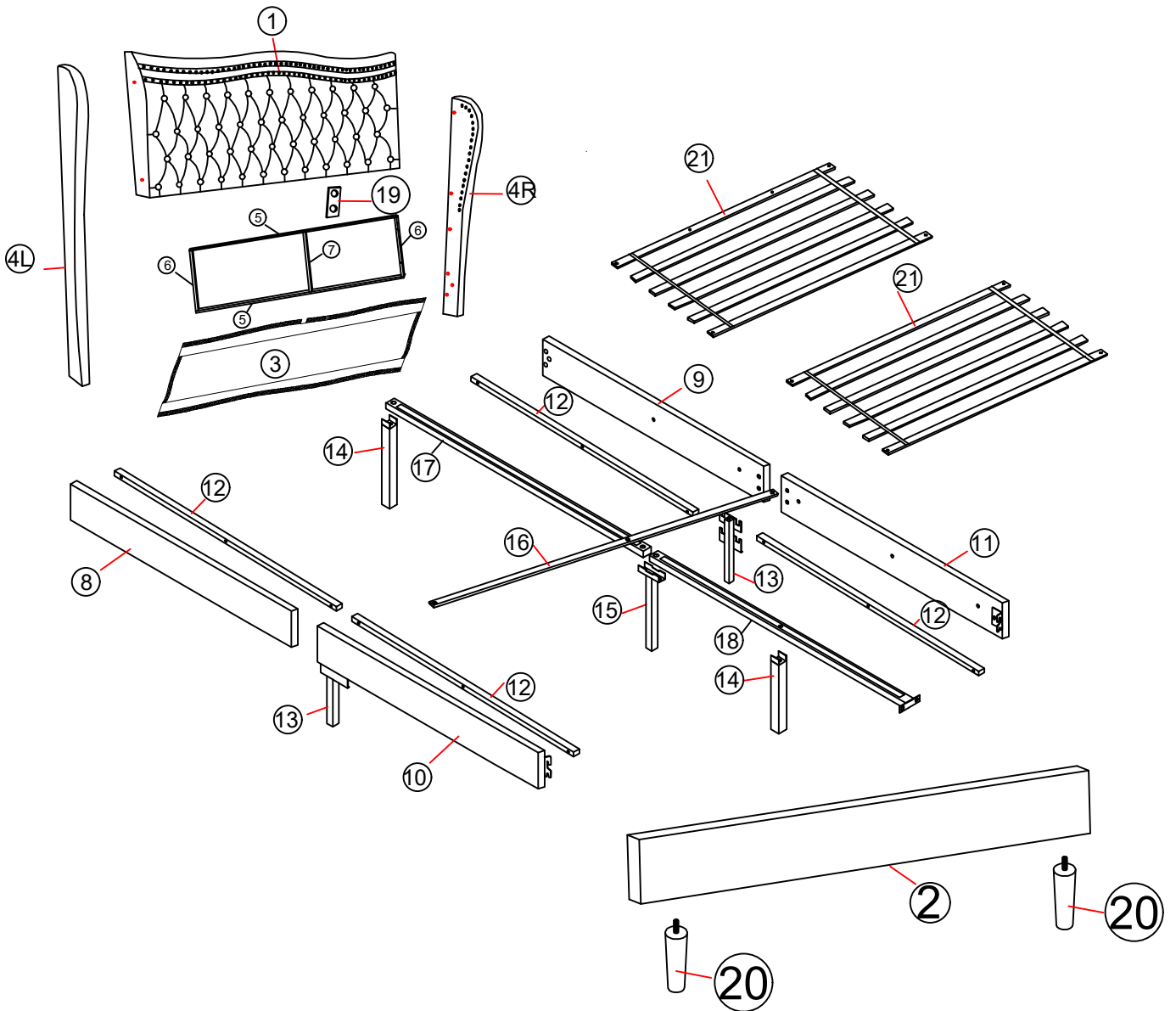

### IMPORTANT NOTE:

- ① PLACE ALL PARTS ON A CLEAN AND SMOOTH SURFACE SUCH AS A RUG OR CARPET TO AVOID THE PARTS FROM BEING SCRATCHED.
- ② BEFORE YOU BEGIN, KINDLY FOLLOW THE ASSEMBLY INSTRUCTIONS STEP BY STEP.
- ③ DO NOT TIGHTEN ALL SCREWS AND BOLTS UNTIL THE CHAIR IS FULLY SET-UP.

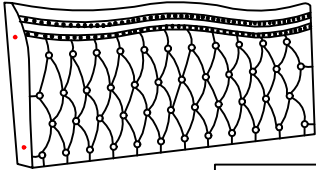

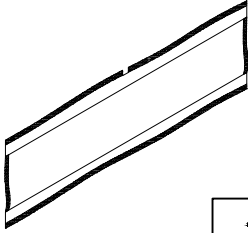
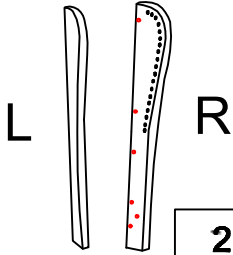
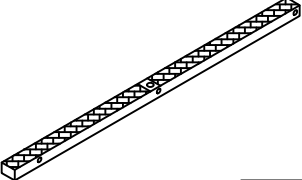
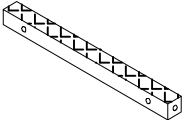
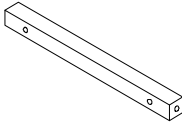
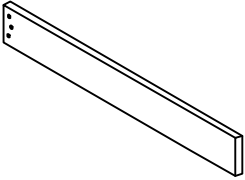
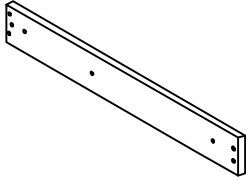
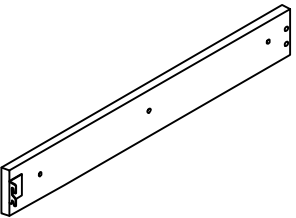
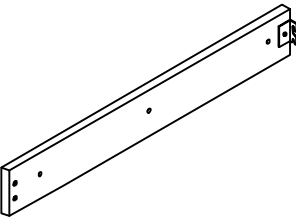
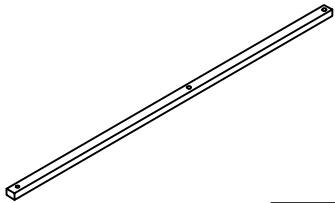
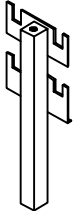
# Explosive view

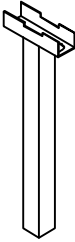
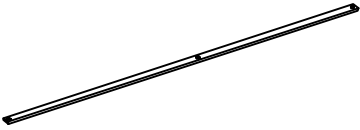

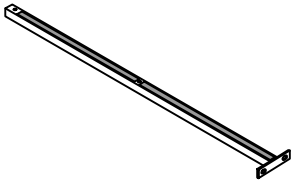



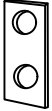

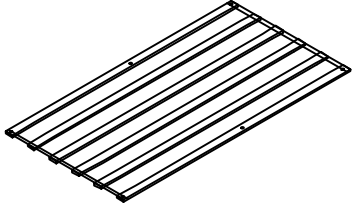
# Parts List

<p>① Headboard Panel (TOP)</p>  <p>1PC</p>	<p>② Footboard</p>  <p>1PC</p>	<p>③ Cover</p>  <p>1PC</p>
<p>④ Headboard Ear</p>  <p>2PCS</p>	<p>⑤ Headboard Panel (Dwon)</p>  <p>2PCS</p>	<p>⑥ Headboard Panel (Dwon)</p>  <p>2PCS</p>
<p>⑦ Headboard Panel (Dwon)</p>  <p>1PC</p>	<p>⑧ Side rail</p>  <p>1PC</p>	<p>⑨ Side rail</p>  <p>1PC</p>
<p>⑩ Side rail</p>  <p>1PC</p>	<p>⑪ Side rail</p>  <p>1PC</p>	<p>⑫ Side rail support</p>  <p>4PCS</p>
<p>⑬ Side rail feet</p>  <p>2PCS</p>	<p>⑭ Support leg</p>  <p>2PCS</p>	<p>⑮ Center support leg</p>  <p>1PC</p>
<p>⑯ Center crossband</p>  <p>1PC</p>	<p>⑰ Center support rail</p>  <p>1PC</p>	<p>⑱ Center support rail</p>  <p>1PC</p>

## Parts List

<p>①9 Connecting iron</p> <div style="text-align: center; margin: 20px 0;">  </div> <div style="text-align: right; border: 1px solid black; padding: 2px 10px; width: fit-content; margin-left: auto;">1PC</div>	<p>②0 Footboard feet</p> <div style="text-align: center; margin: 20px 0;">  </div> <div style="text-align: right; border: 1px solid black; padding: 2px 10px; width: fit-content; margin-left: auto;">2PCS</div>	<p>②1 Slats</p> <div style="text-align: center; margin: 20px 0;">  </div> <div style="text-align: right; border: 1px solid black; padding: 2px 10px; width: fit-content; margin-left: auto;">2 SETS</div>
---	---	--

## Hardware List

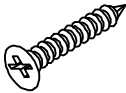
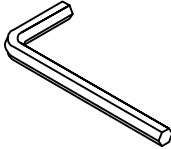
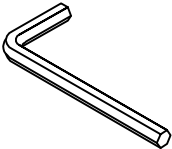
<p><b>A</b></p> <div style="text-align: center; margin: 20px 0;">  </div> <p style="text-align: center;">Ø5/16"×25mm</p> <div style="text-align: right; border: 1px solid black; padding: 2px 10px; width: fit-content; margin-left: auto;">6PCS</div>	<p><b>B</b></p> <div style="text-align: center; margin: 20px 0;">  </div> <p style="text-align: center;">Ø5/16"×40mm</p> <div style="text-align: right; border: 1px solid black; padding: 2px 10px; width: fit-content; margin-left: auto;">17+2PCS</div>	<p><b>C</b></p> <div style="text-align: center; margin: 20px 0;">  </div> <p style="text-align: center;">Ø1/4"×38mm</p> <div style="text-align: right; border: 1px solid black; padding: 2px 10px; width: fit-content; margin-left: auto;">22+2PCS</div>
<p><b>D</b></p> <div style="text-align: center; margin: 20px 0;">  </div> <p style="text-align: center;">Ø1/4"×15mm</p> <div style="text-align: right; border: 1px solid black; padding: 2px 10px; width: fit-content; margin-left: auto;">10+1PCS</div>	<p><b>E</b></p> <div style="text-align: center; margin: 20px 0;">  </div> <p style="text-align: center;">Ø5/16"×13mm</p> <div style="text-align: right; border: 1px solid black; padding: 2px 10px; width: fit-content; margin-left: auto;">23+2PCS</div>	<p><b>F</b></p> <div style="text-align: center; margin: 20px 0;">  </div> <p style="text-align: center;">Ø5/16"×19mm</p> <div style="text-align: right; border: 1px solid black; padding: 2px 10px; width: fit-content; margin-left: auto;">23+2PCS</div>
<p><b>G</b></p> <div style="text-align: center; margin: 20px 0;">  </div> <p style="text-align: center;">Ø1/4"×16mm</p> <div style="text-align: right; border: 1px solid black; padding: 2px 10px; width: fit-content; margin-left: auto;">32+3PCS</div>	<p><b>H</b></p> <div style="text-align: center; margin: 20px 0;">  </div> <p style="text-align: center;">M4×25mm</p> <div style="text-align: right; border: 1px solid black; padding: 2px 10px; width: fit-content; margin-left: auto;">8+1PCS</div>	<p><b>I</b></p> <div style="text-align: center; margin: 20px 0;">  </div> <p style="text-align: center;">Ø5/16"</p> <div style="text-align: right; border: 1px solid black; padding: 2px 10px; width: fit-content; margin-left: auto;">1PC</div>
<p><b>J</b></p> <div style="text-align: center; margin: 20px 0;">  </div> <p style="text-align: center;">Ø1/4"</p> <div style="text-align: right; border: 1px solid black; padding: 2px 10px; width: fit-content; margin-left: auto;">1PC</div>		

# Assembly Steps

## STEP 1

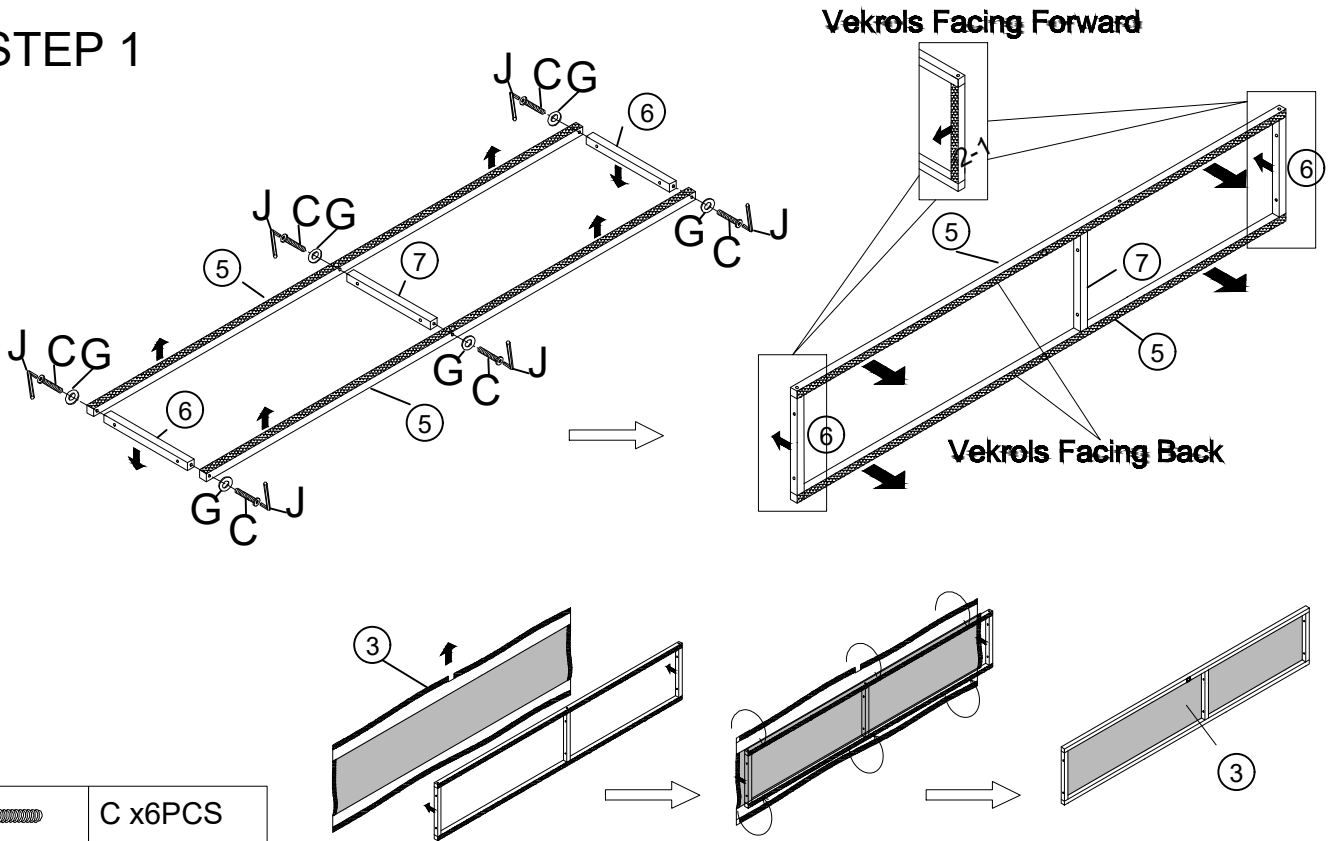

	C x 6PCS
	G x 6PCS
	J x 1PC

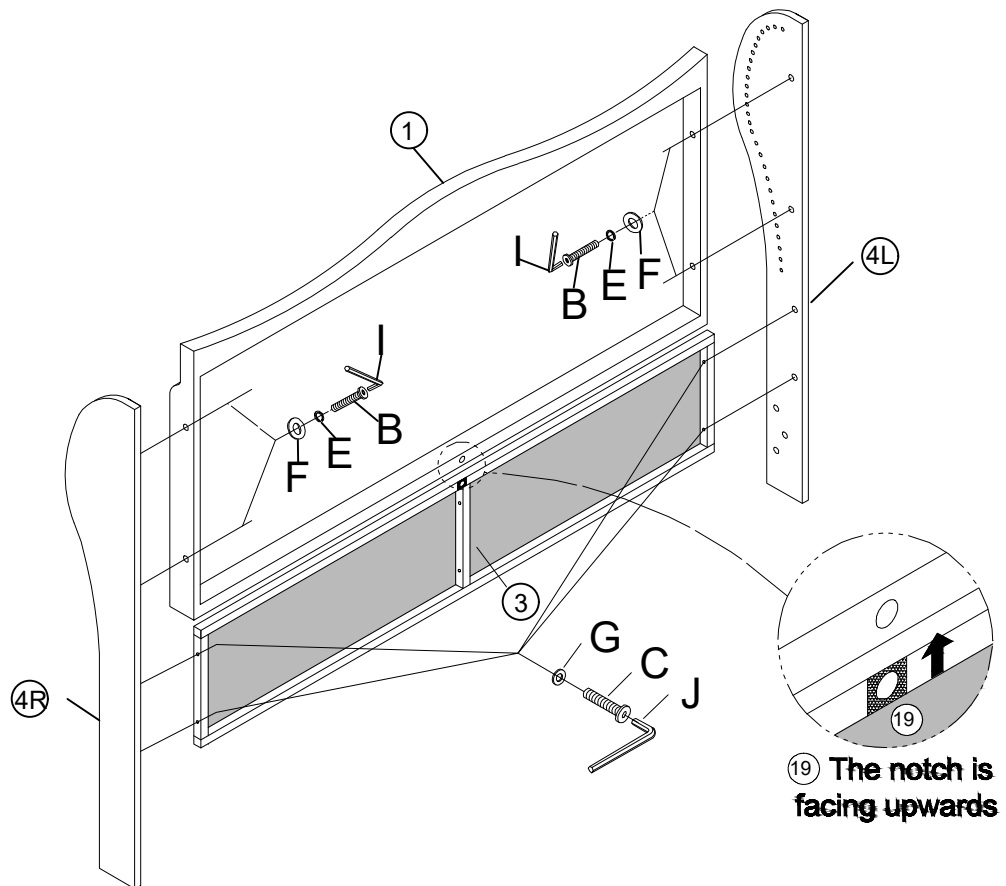

## STEP 2

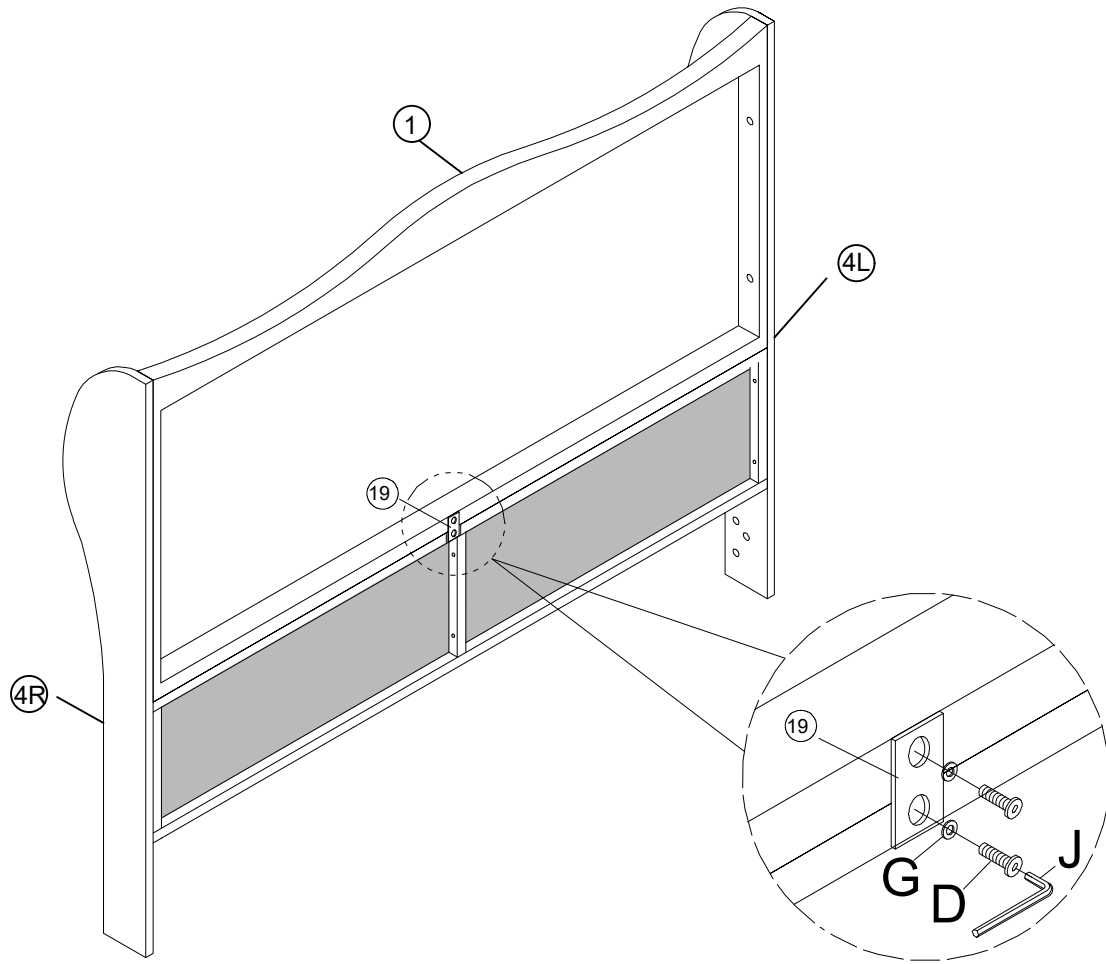

	B x 4PCS
	E x 4PCS
	F x 4PCS
	I x 1PC
	C x 4PCS
	G x 4PCS
	J x 1PC

# STEP 3





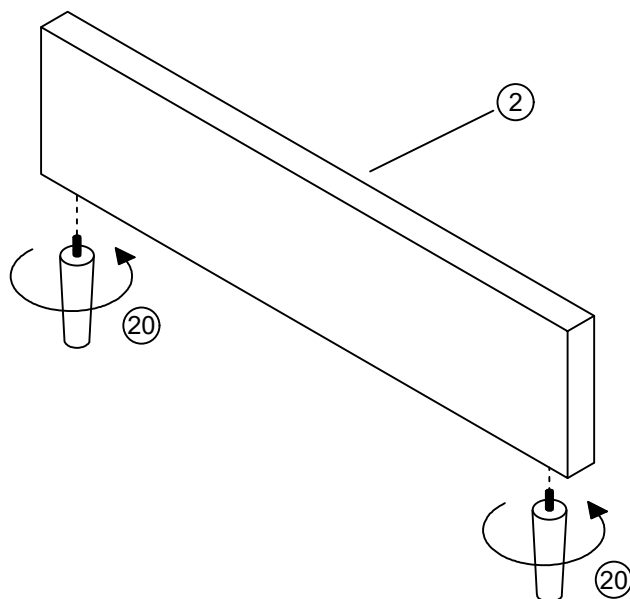

	D x 2PCS
	G x 2PCS
	J x 1PC

# STEP 4

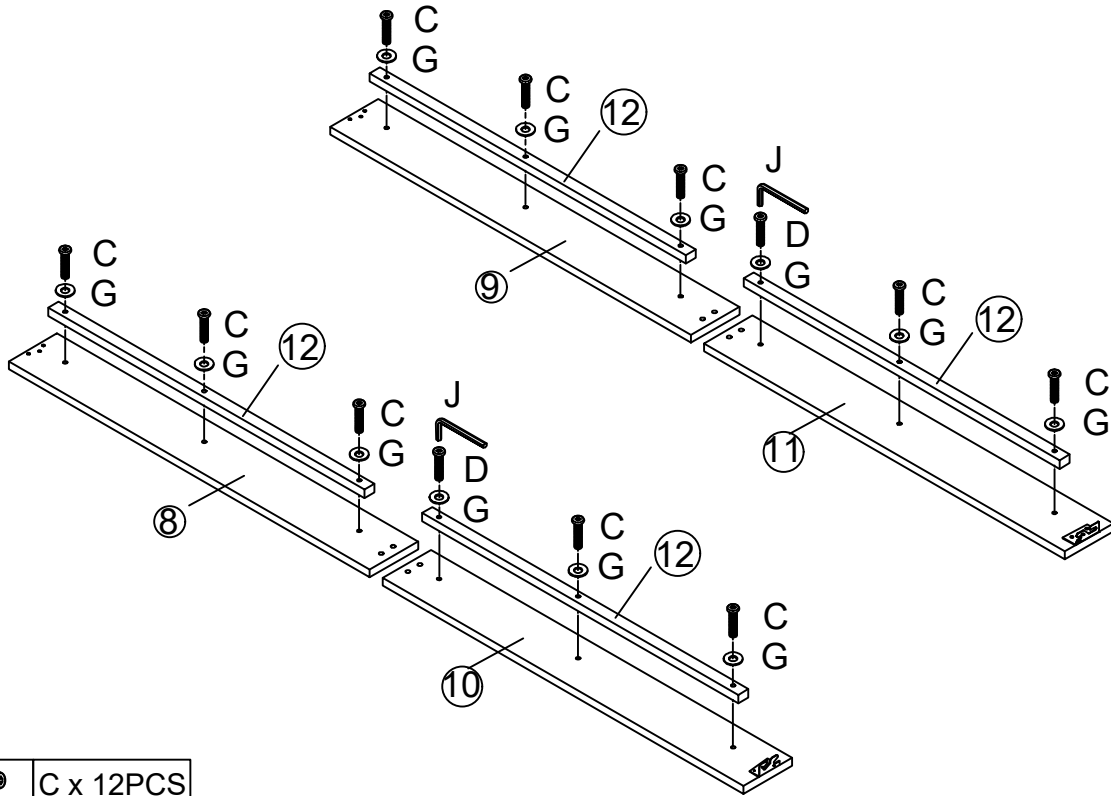





# STEP 5

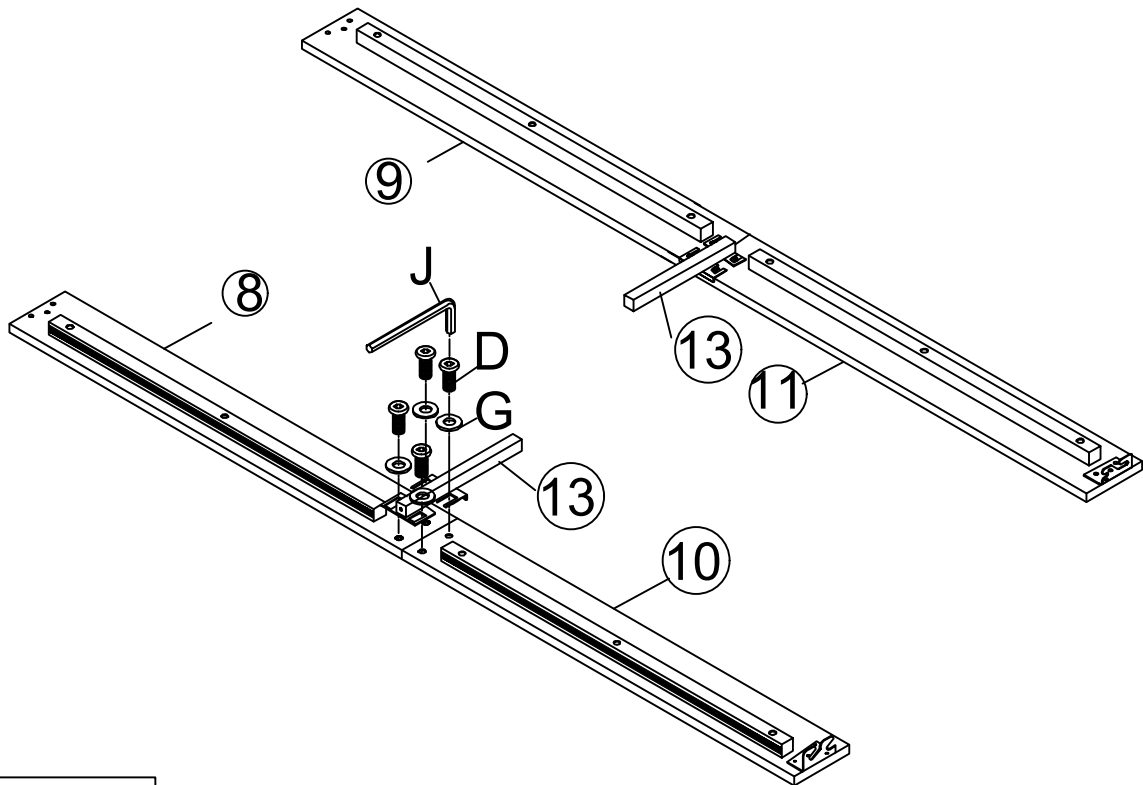

	C x 12PCS
	G x 12PCS
	J x 1PC

# STEP 6



	D x 8PCS
	G x 8PCS
	J x 1PC

# STEP 7

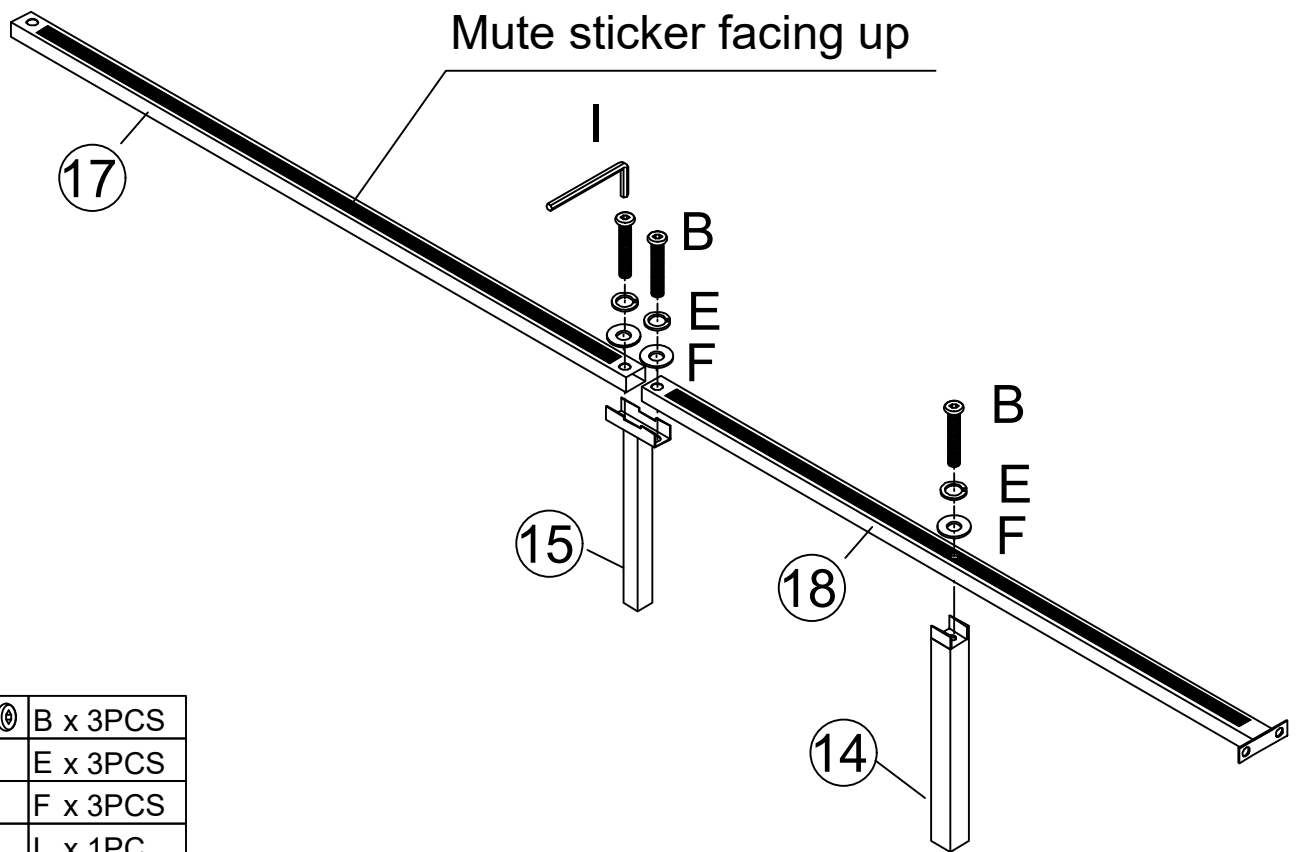

	B x 3PCS
	E x 3PCS
	F x 3PCS
	I x 1PC



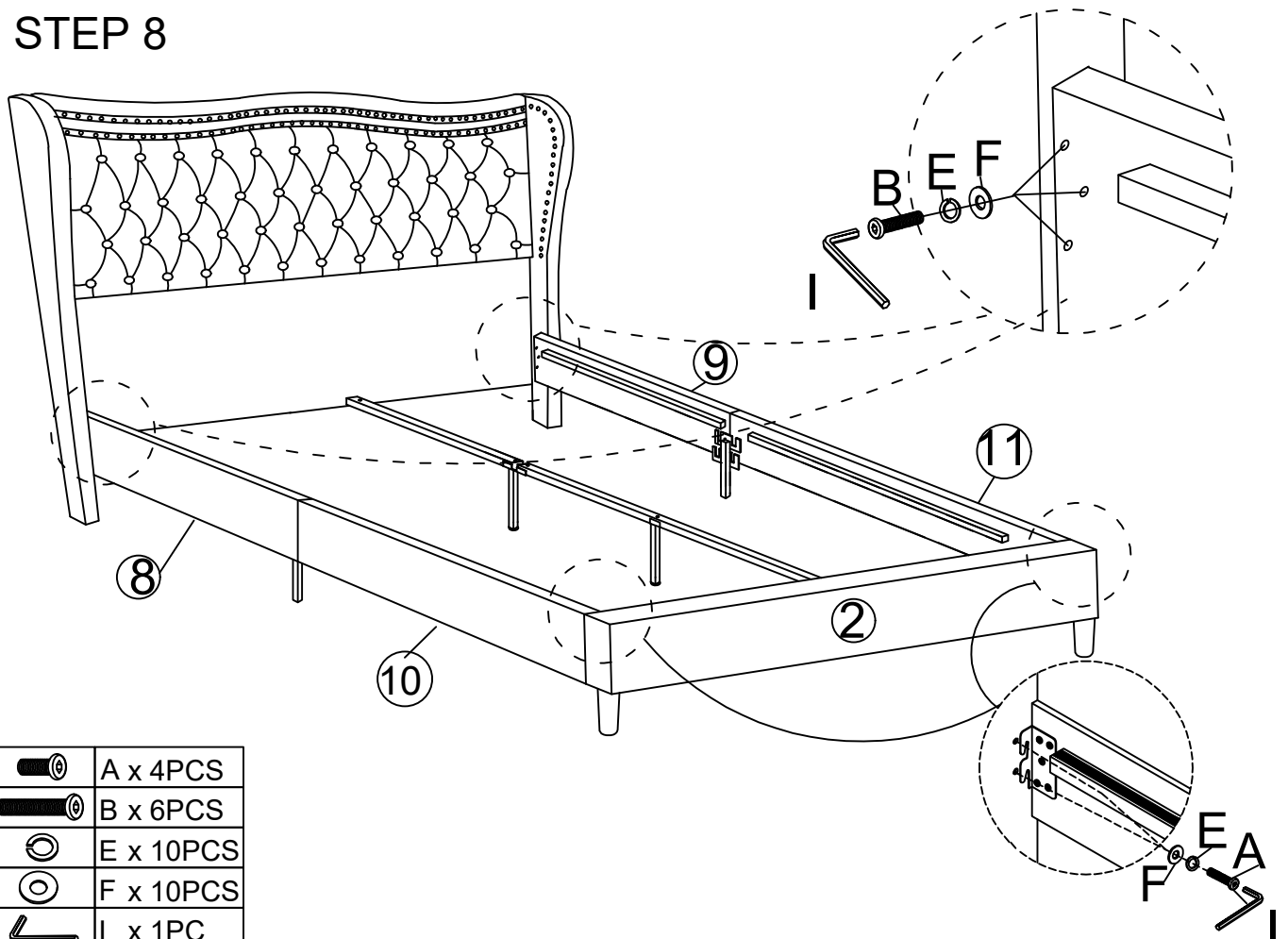

# STEP 8

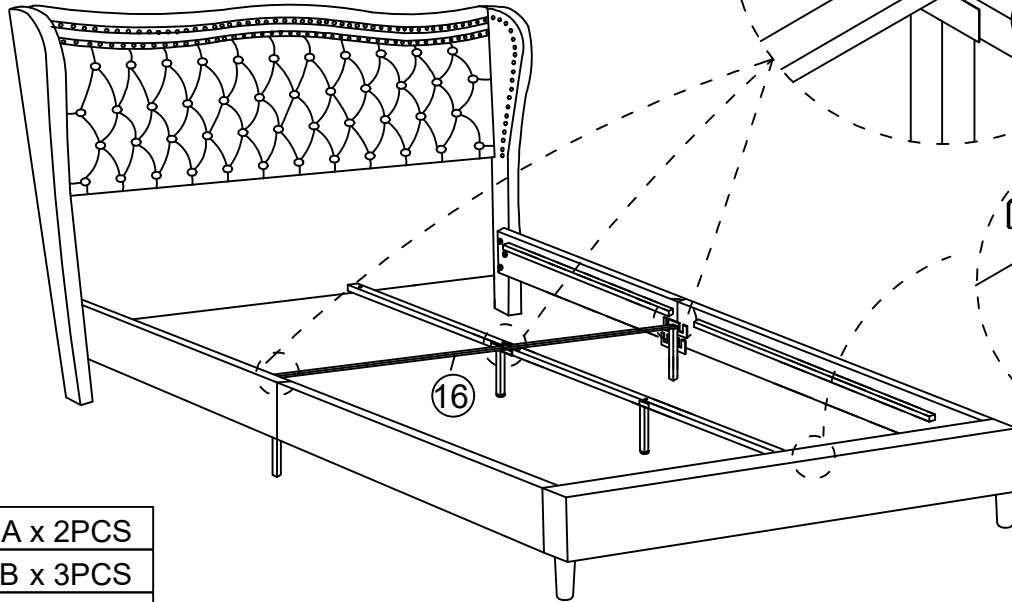

	A x 4PCS
	B x 6PCS
	E x 10PCS
	F x 10PCS
	I x 1PC

# STEP 9





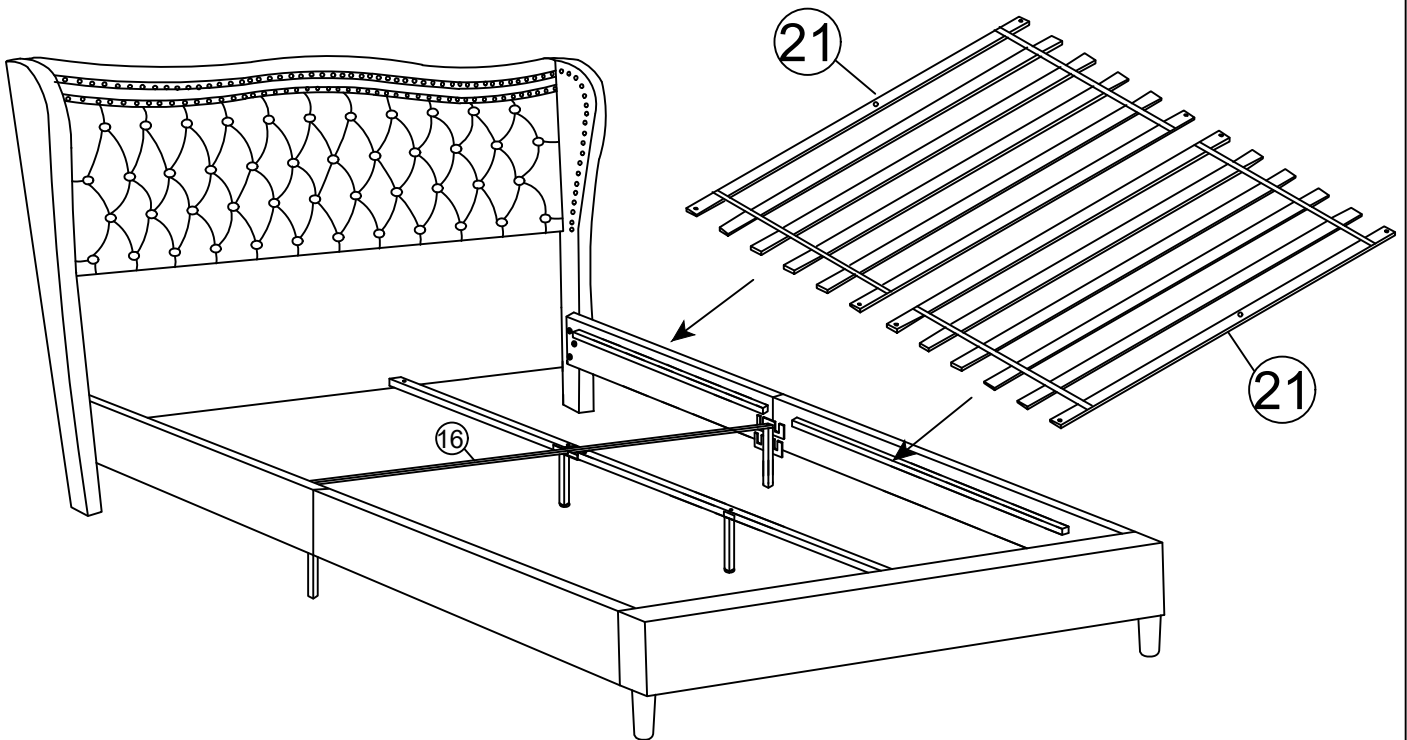

	A x 2PCS
	B x 3PCS
	E x 5PCS
	F x 5PCS
	I x 1PC

# STEP 10

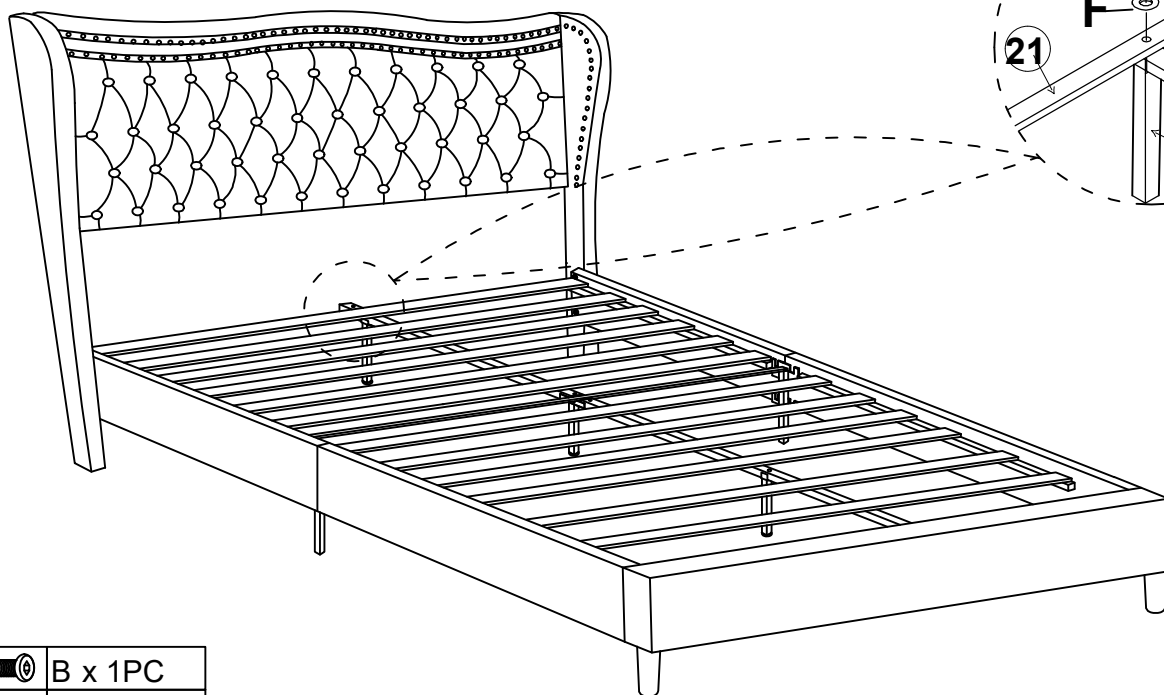



# STEP 11

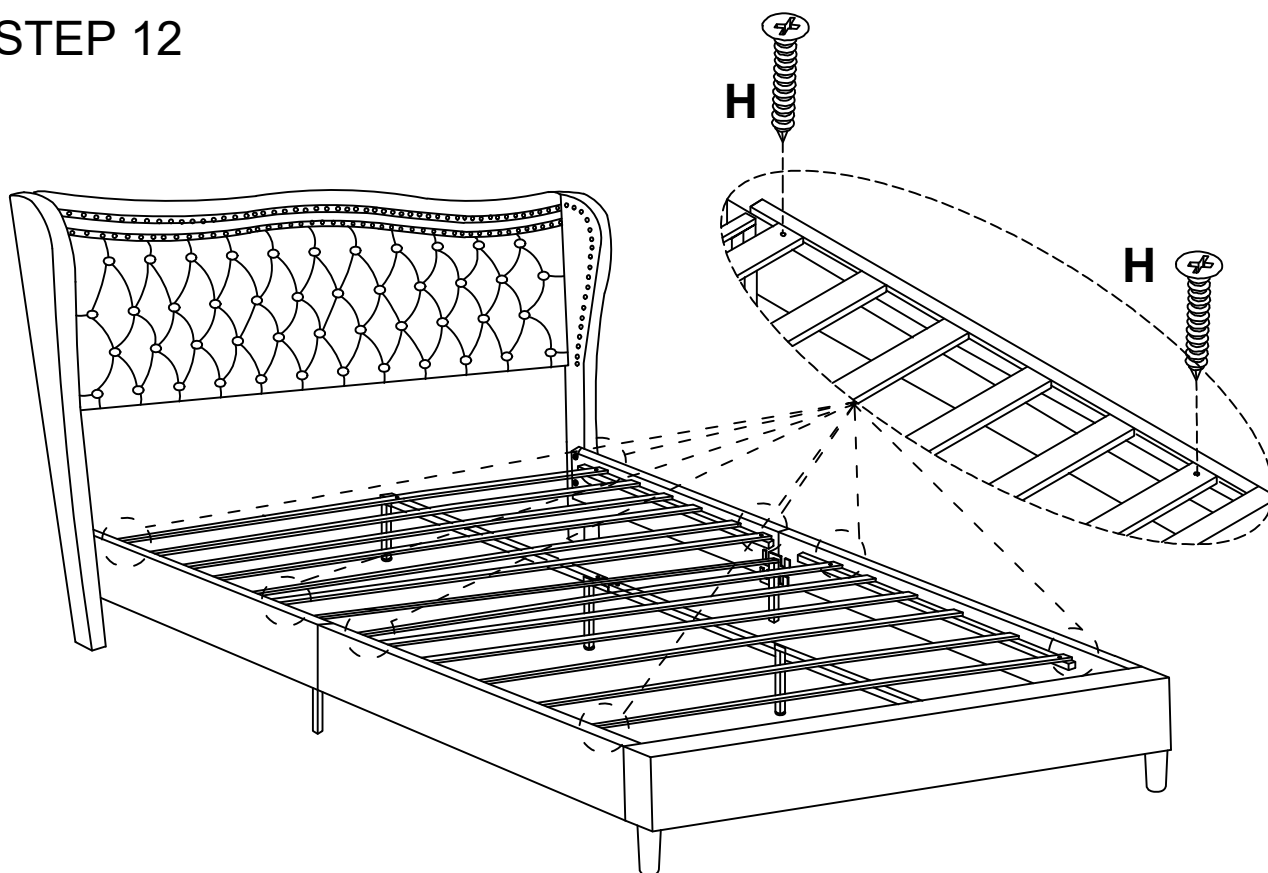

	B x 1PC
	E x 1PC
	F x 1PC
	I x 1PC

# STEP 12



	H x 8PCS
---	----------