

Assembly Instructions

CAUTION: You must read this before you proceed.

Please look in the Table Top for hardware packs.

Table

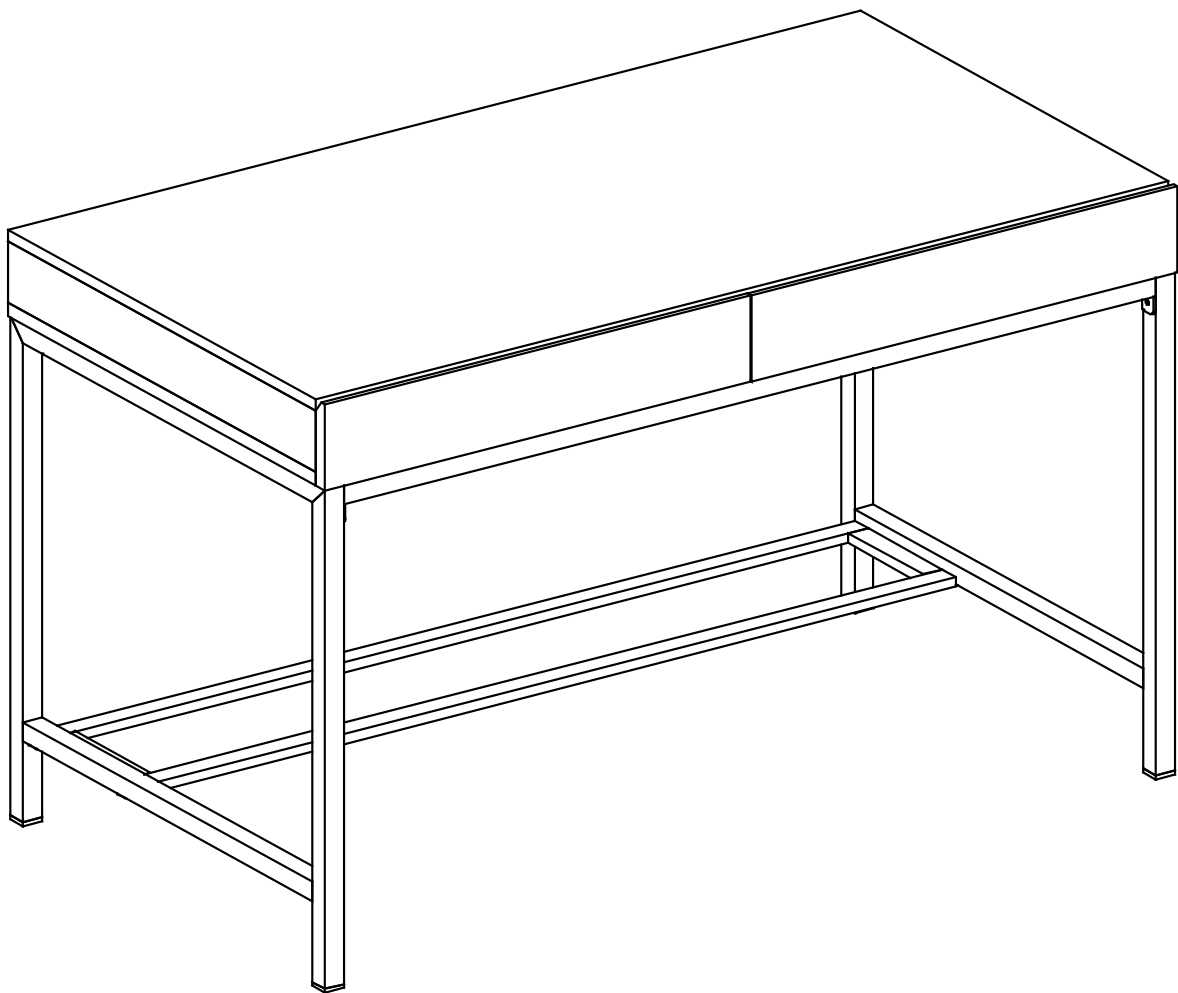







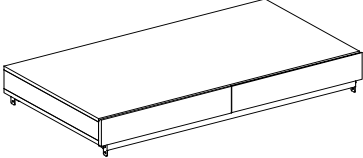
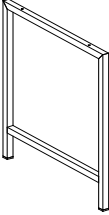
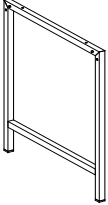
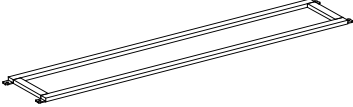

CAUTION : This Table is NOT a TOY. Keep your child / children at bay in the process of assembly.

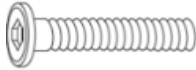
For turning the Table and to prevent damage to the Table, 02 persons may be needed to execute this action.

Parts List

No.	Picture	Description	Qty
A		Table top	1
B		Left Leg Panel	1
C		Right Leg Panels	1
D		Support Bar	1

Hardware

No.	Picture	Description	Qty
①		Bolts (M6x15mm)	13
②		Screws (M6x40mm)	5
③		Flat Washers (M6)	17
④		Allen Key	1
⑤		Screws (M4x20mm)	2
⑥		Screws (M4x50mm)	2
⑦		Metal Bracket	4
⑧		Table Restraint Strap	2

Assembly Preparation

Before Beginning Assembly:

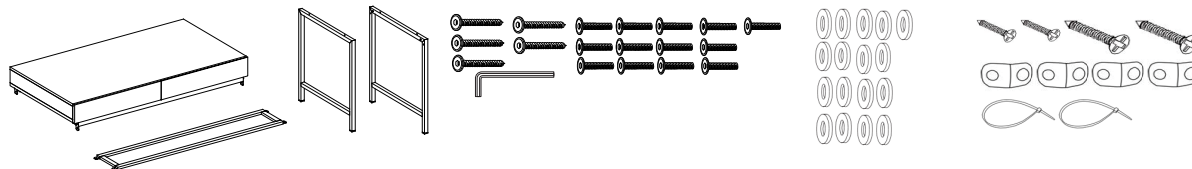

Read the instructions, cover to cover.



Have 2 adults on hand for assembly.



Do not assemble on flooring or carpet.



Assemble on a clean non-marring surface (packing foam).



Save all packaging until finished.

Assembly Steps

OVERVIEW

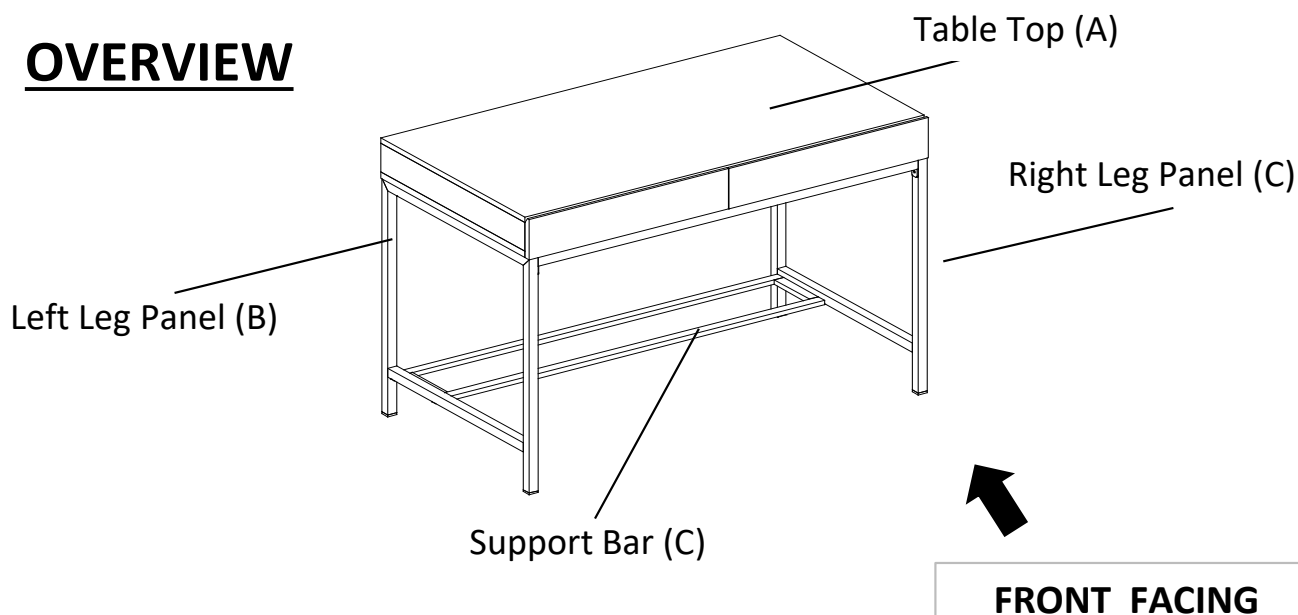

This Table has multiple parts and may require up to some 30 minutes to assemble. To give you an overview of the Table parts, the above picture is to help you put the various parts into perspective. Please read through the instructions here below to familiarise the parts and steps before assembly.

Step 1

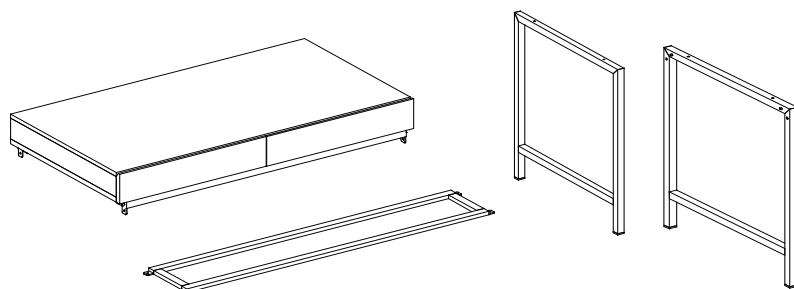

Unpack and place all parts on a clean non marring flat surface .

Step 2

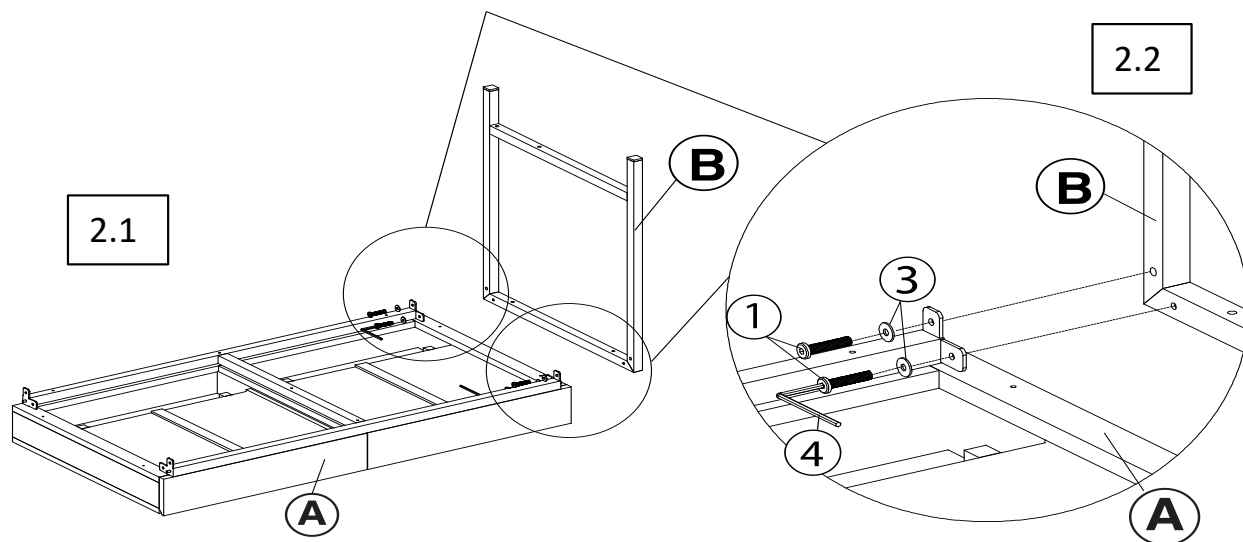

Step 2.1: Place the Table Top (A) facedown, onto a clean, soft surface to avoid any scratches or damages to the product.

Step 2.2: Position the Leg Panel (B) into the Table Top (A) as shown in picture above.

Then affix Left Leg Panel (B) to Table Top (A) by using Bolt (1), Flat washer (3) and Allen Key (4).

Step 2.3: Repeat the same process 2.2 to affix Right Leg Panel (C) to Table Top (A).

DO NOT FULLY TIGHTEN THE BOLTS

Step 3

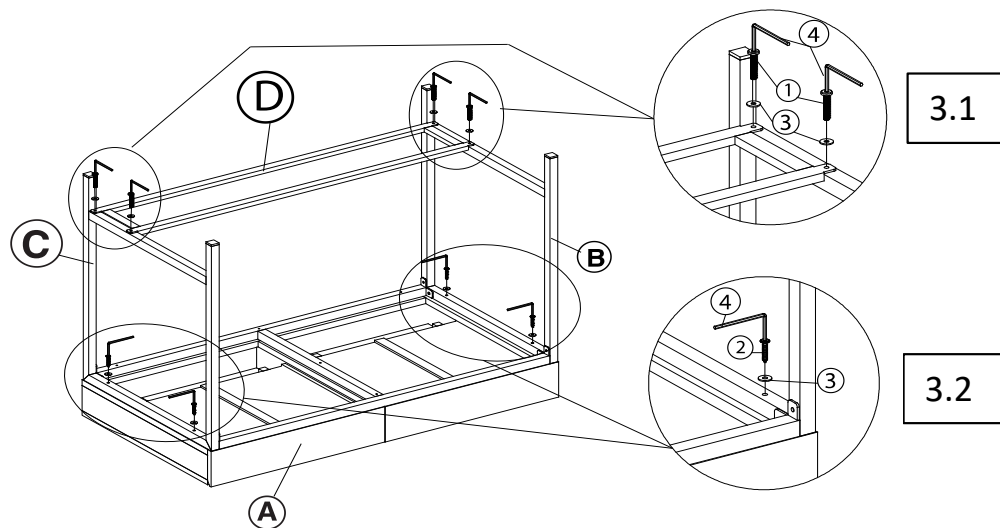

Step 3.1: Affix Support Bar (D) to Leg Panels (B),(C) by using Bolts (1) Flat washer (3) and Allen Key (4). You may need to push the Leg Panels (B),(C) outwards slightly to attach the Support bar (D).

Step 3.2: Secure the iron frame to the wooden table top by using Screws (2), flat washer (3) and Allen Key (4)

DO NOT FULLY TIGHTEN THE BOLTS/SCREWS.

Step 5

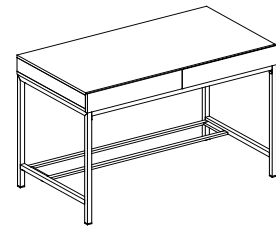
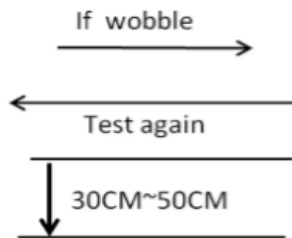
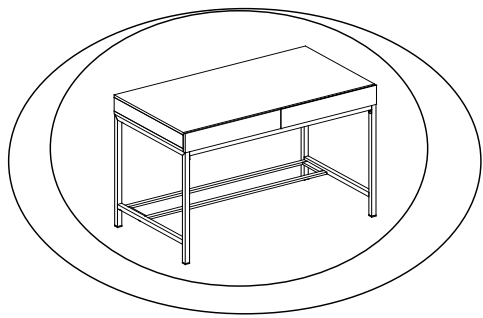

Turn the Table right side up
Place the Table on a LEVEL SURFACE to see if it wobbles.

If it wobbles, lift the Table to some 30cm to 50cm height from the ground.
Keep your feet and toes well away from the drop zone.
Drop the Table freely and vertically with the four legs, hitting the ground, at the same time.
This Drop Test will help to ensure that all the screws and gaps to all reach full alignment status.
Test again for evenness on a LEVEL SURFACE.
If no wobbles found, proceed to tighten all the screws.

**CAUTION: When tightening these screws, tighten sequentially.
DO NOT tighten any screw fully and then towards the next one.
This would cause the frame to warp.
If there is still wobbles, loosen the screws and execute this same drop tests.
WARNING ! IF TABLE IS NOT STABLE , IT COULD LEAD TO DAMAGE THE PRODUCT.**

Step 6

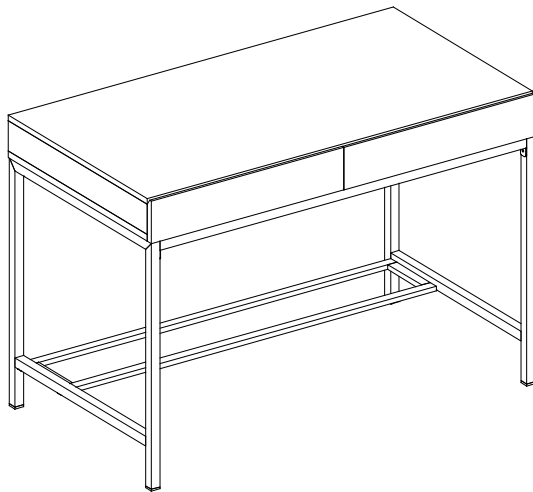

Ensure all screws are fully locked into position.
The Table is ready to be used.
Caution: This Table can only be used on a flat, level surface.



WARNING

Serious or fatal crushing injuries can occur from tipping furniture. To help prevent tip-over: ALWAYS secure this furniture to the wall using Cabinet Restraint Device. See product instructions for more ways to help prevent furniture tip-over.

Step 7

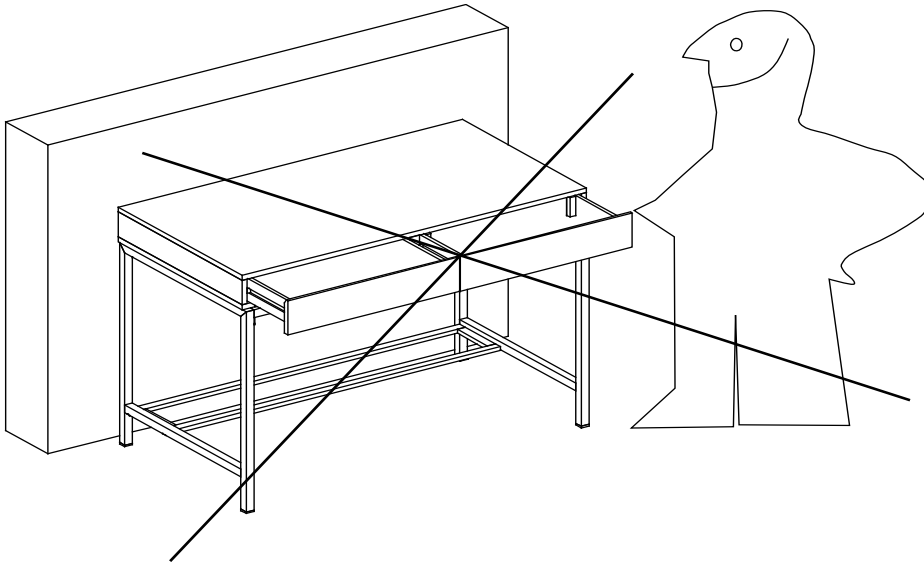

Usage For Table Restraint Device :

For Table against wall, fix 2pcs Metal Brackets(⑦) on wall and 2pcs Metal Brackets(⑦) on product, use **Table Restraint Strap(⑧)** to connect the Metal Bracket(⑦) on wall and product. Find details as below:

Step 8

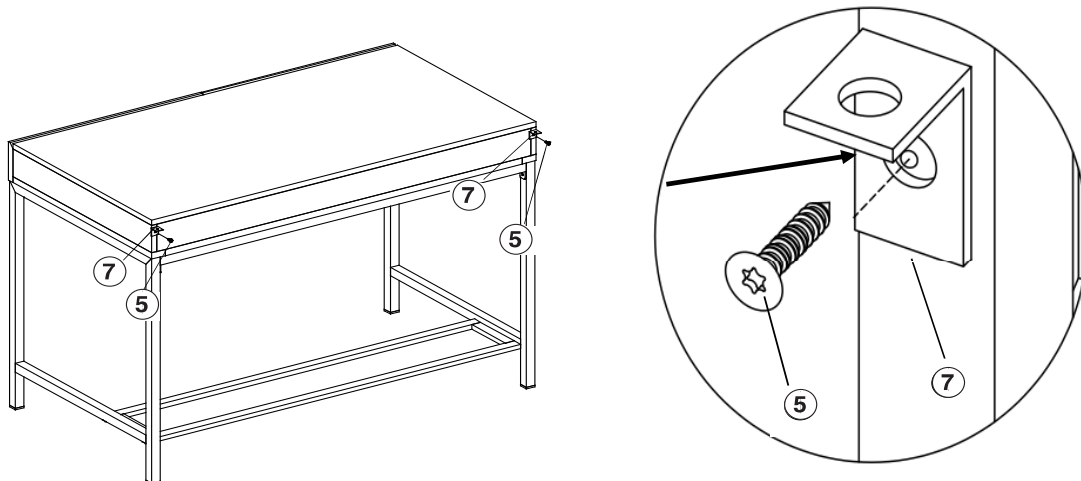

A: Firstly, turn back the Cabinet outwards as shown above.

Then fix one Metal Bracket (⑦) on the Back Table by the Screws 2 cm Self Tapping Screws (⑤) . The distance between the left edge of the leg and bracket is 0.3inch. The distance between the right edge of the leg and bracket is 0.3inch

Repeat this step to fix another Metal Bracket (⑦) on product, as shown above.

Step 9

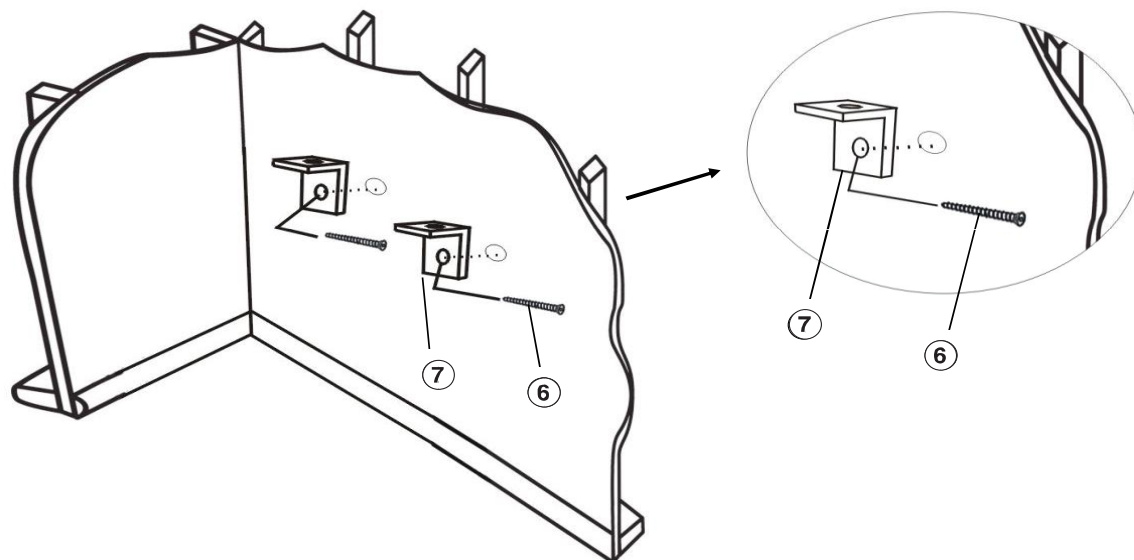

B : Find out the screw holes on the wall.

First, mark the point at same height on the wall as L-shaped Metal Bracket (7) on product. You can find these same points in two ways as below:

1. Move the Table back to the wall ,make these points on the wall and product are at same height

2. Measure the height of the Metal Bracket and the wall by ruler ,keep them are accurately and same height.

(Caution: The Table Restraint Strap (8) between Metal Brackets on product and wall should be within 3.5" .)

Then fix one L-shaped Metal Bracket on the mark on wall by the 5cm Self Tapping Screws (6).

Repeat this step to fix another Metal Bracket (7) on wall, as shown above.



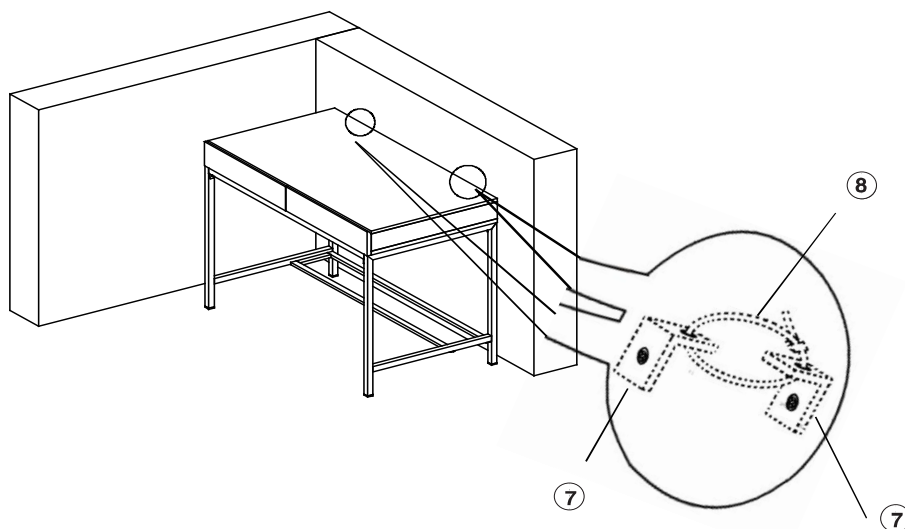







Step 10



C: Move the Table against the wall. Then pull the Table Restraint Strap (8) through two Metal Brackets (7) one by one, lock tight the Table Restraint Strap (8), as shown above.

Table Restraint Device is installed and Table is ready for use.

Care & Maintenance

-  Do not put hot items directly on furniture surface.
 -  Do not clean furniture with harsh cleansers or polish.
 -  Do not place furniture under direct sunlight.
 -  Do not place furniture near heating or cooling vents.
 -  Do not write on furniture without a padded barrier to protect the surface.
 -  Do not place furniture outside. For indoor use only.
 -  Not for commercial use. For residential use only.
 -  Stains may be removed with mild soap solution and damp cloth.
 -  Children should not climb or jump on the furniture.
-
-  Dust and pick-up spills using a clean, non-colored, lint-free cloth.