

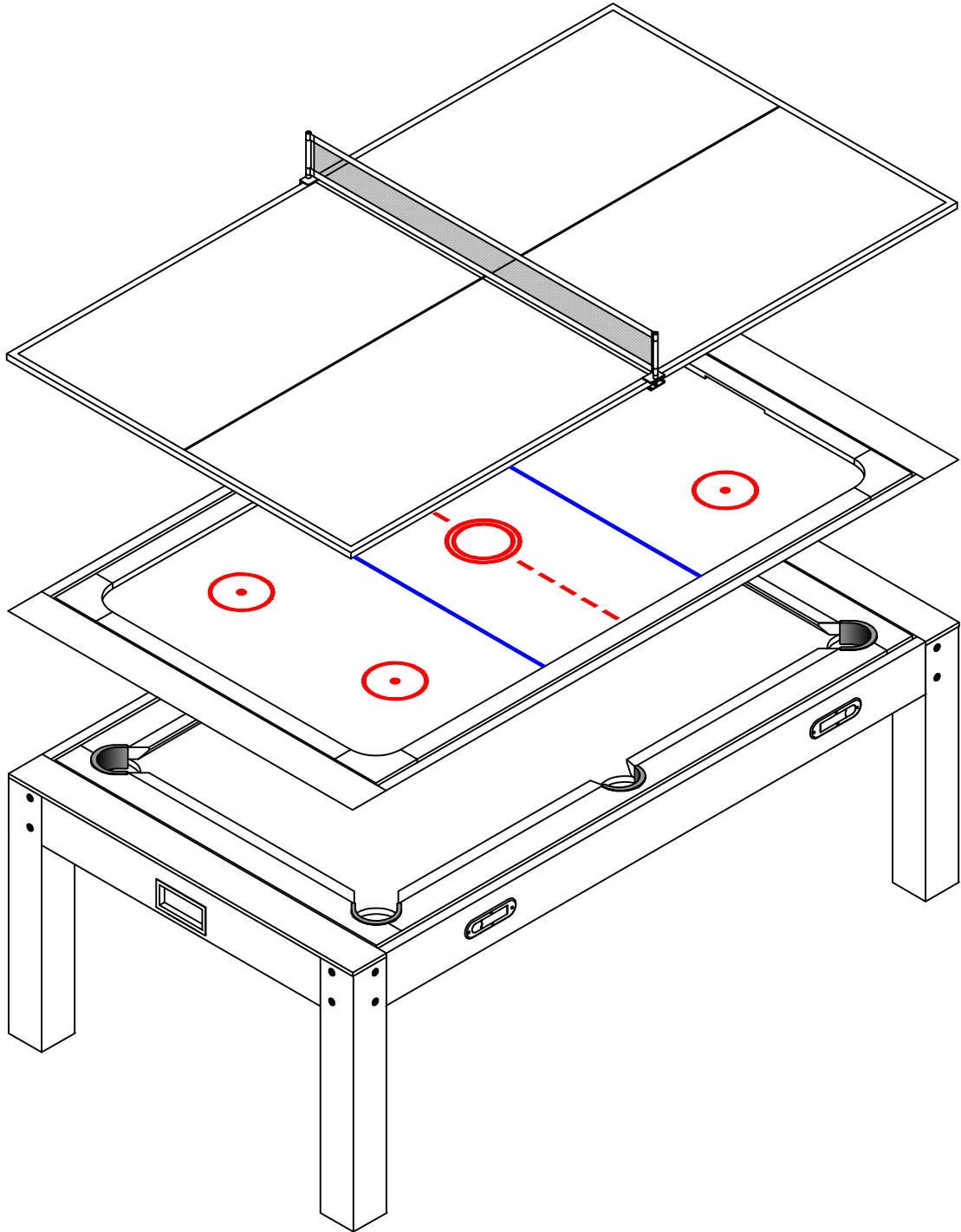

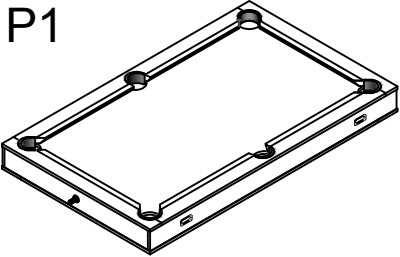

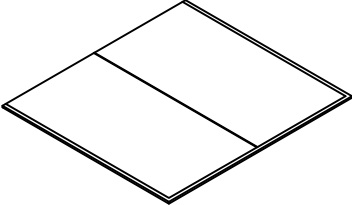

REVOLVER

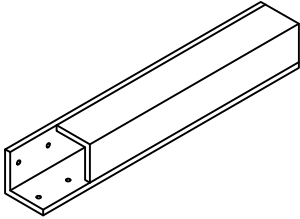
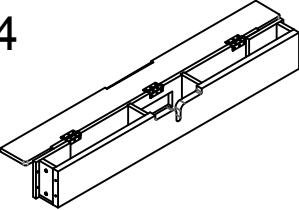
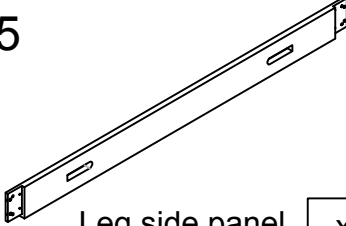

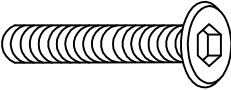
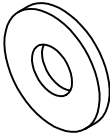

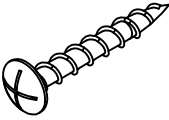



MULTI GAMES TABLE

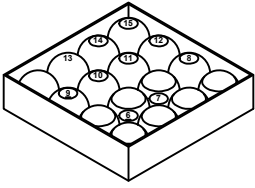

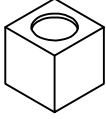
PARTS IDENTIFIER

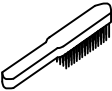
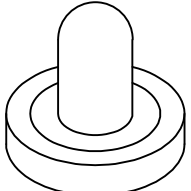
<p>P1</p>  <p>Pool table x1</p>	<p>P2</p>  <p>Table tennis surface x2</p>	<p>P3</p>  <p>Leg x4</p>
<p>P4</p>  <p>Leg End panel x2</p>	<p>P5</p>  <p>Leg side panel x2</p>	<p>P6</p>  <p>Latches x4</p>
<p>P7</p>  <p>Leg leveler x4</p>		
<p>H1</p>  <p>Bolt x16</p>	<p>H2</p>  <p>Washer x16</p>	<p>H3</p>  <p>Screw x16</p>
<p>H4</p>  <p>Screw x16</p>	<p>H5</p>  <p>Wood plug x2</p>	<p>H6</p>  <p>Bolt x2</p>

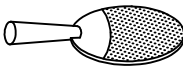
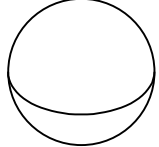
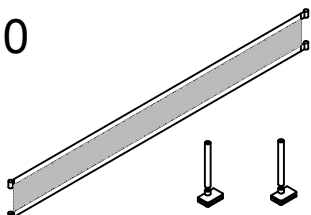
PARTS IDENTIFIER

<p>A1</p>  <p>Billiard ball x1</p>	<p>A2</p>  <p>Triangle rack x1</p>	<p>A3</p>  <p>Chalk x2</p>
<p>A4</p>  <p>Cue stick x2</p>	<p>A5</p>  <p>Plastic brush x1</p>	<p>A6</p>  <p>Hockey striker x2</p>
<p>A7</p>  <p>Hockey Puck x2</p>	<p>A8</p>  <p>Table tennis paddle x2</p>	<p>A9</p>  <p>Table tennis ball x2</p>
<p>A10</p>  <p>Table tennis net x1</p>	<p>A11</p>  <p>Allen key tool x1</p>	

ASSEMBLY INSTRUCTIONS

WARNING: TWO ADULTS NEEDED ASSEMBLE POOL TABLE

Instructions before assembly:

Count all the parts and quantities according to the parts list to prepare the assembly below.

Figure 1

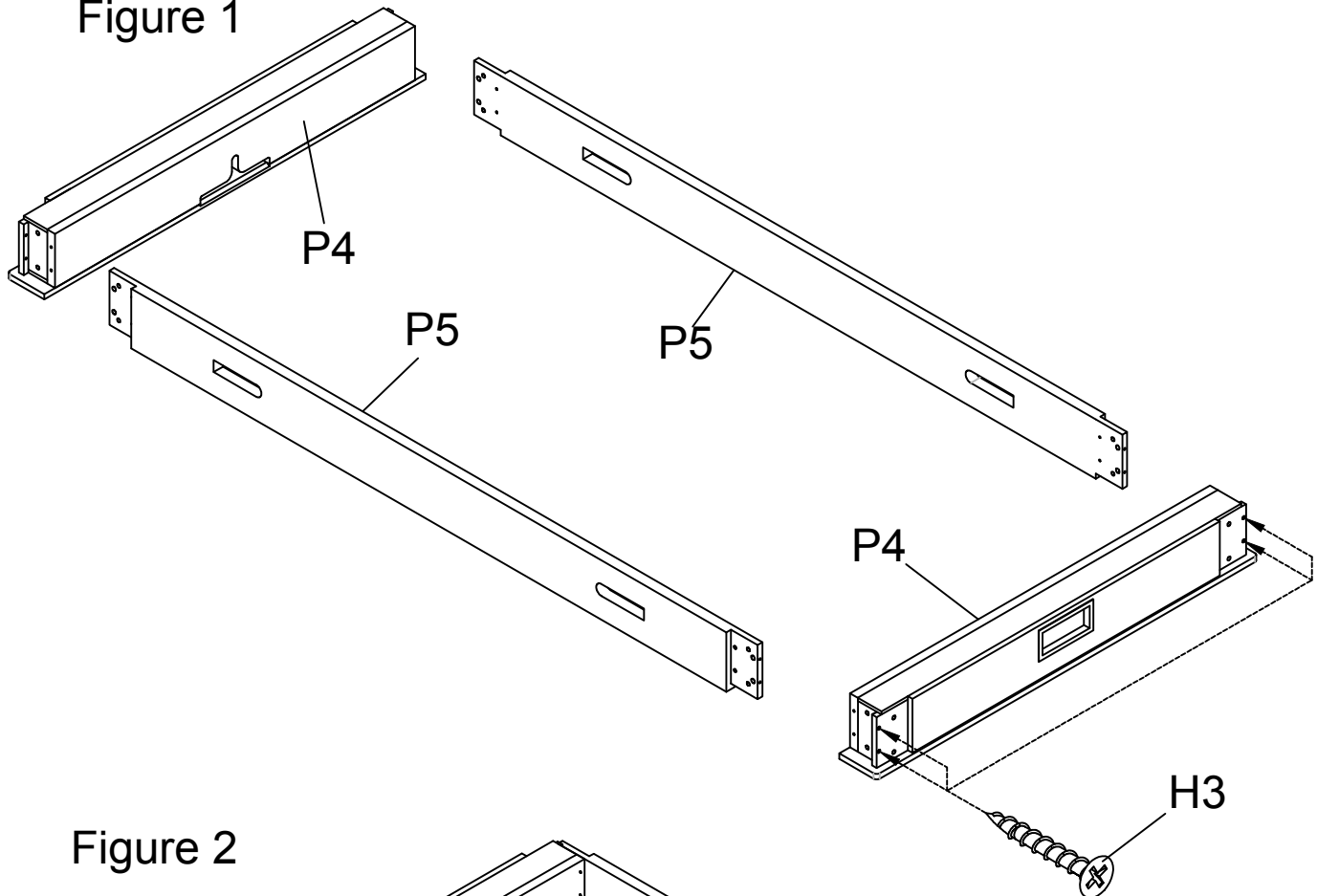
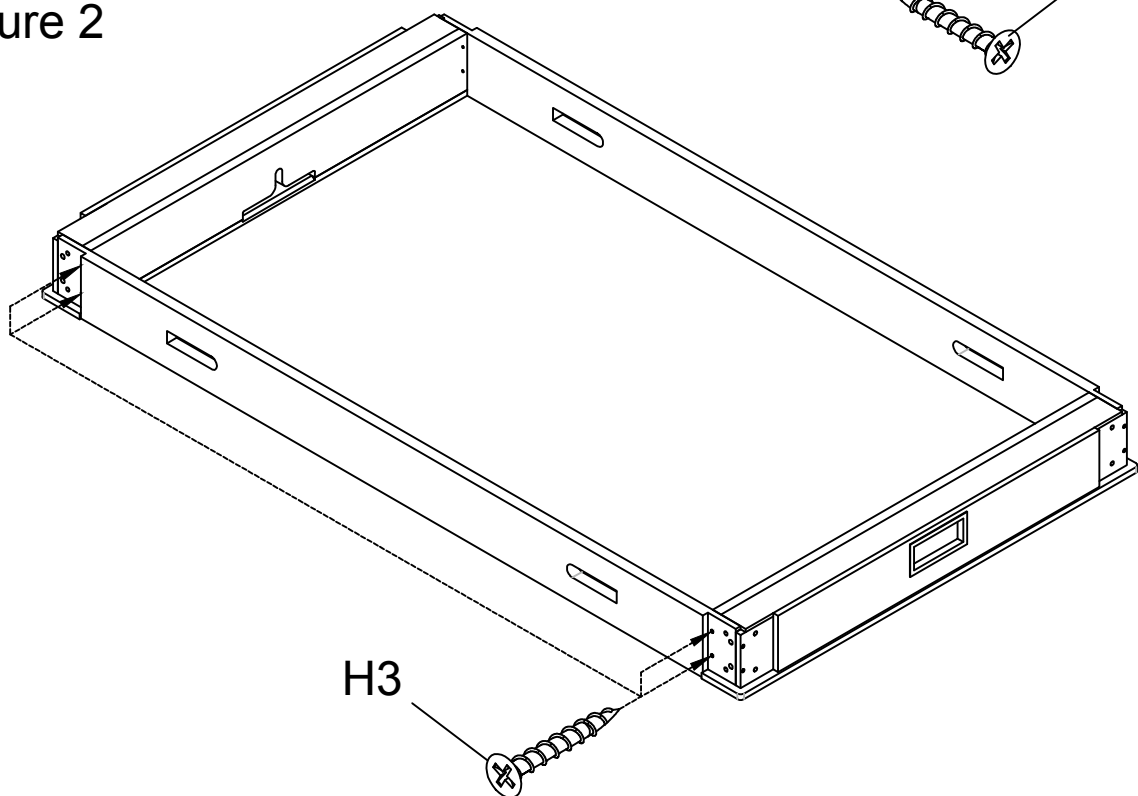

Figure 2



ASSEMBLY INSTRUCTIONS

WARNING: TWO ADULTS NEEDED ASSEMBLE POOL TABLE

Figure 3

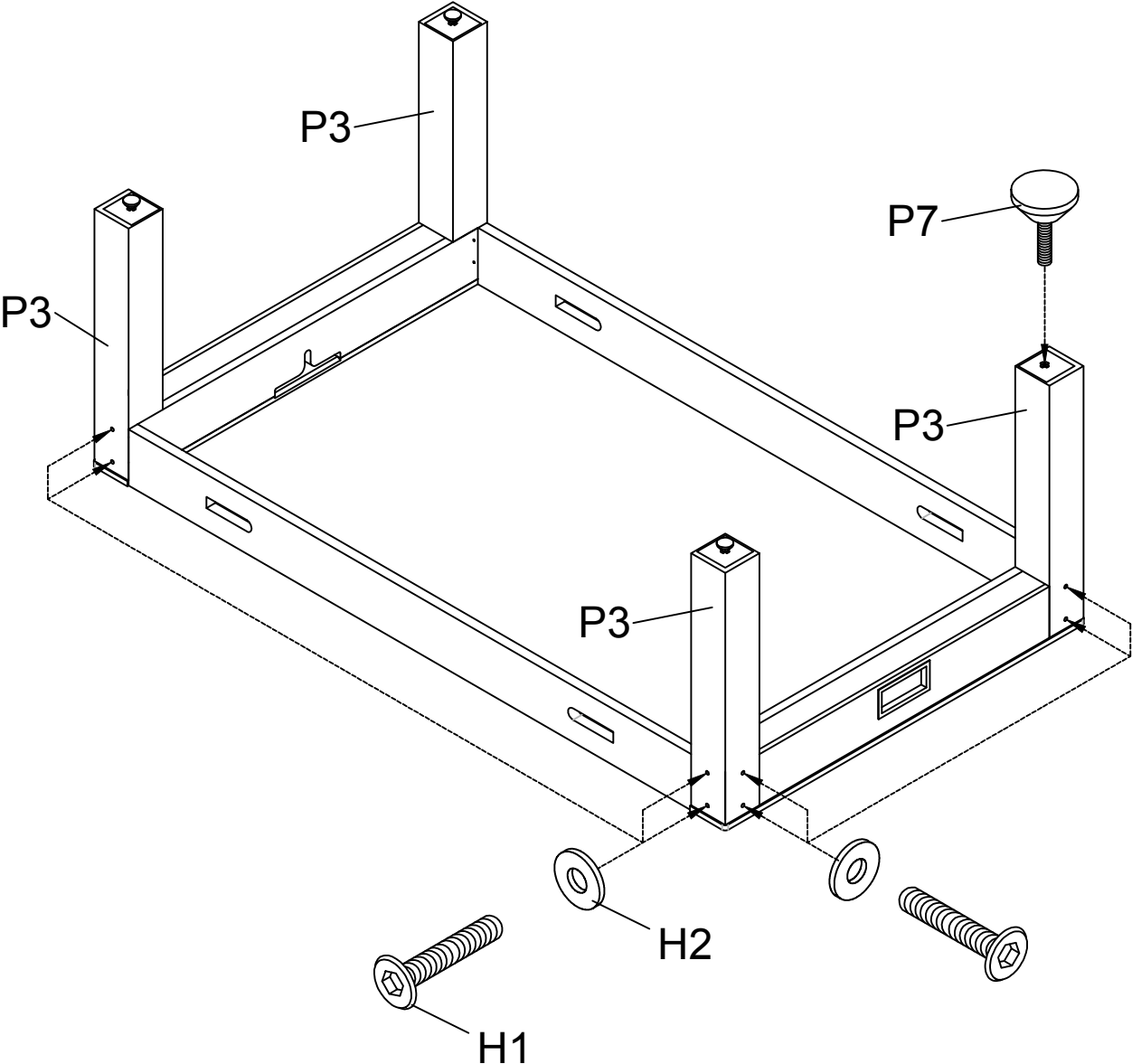

ASSEMBLY INSTRUCTIONS

WARNING: YOU WILL NEED A SECOND ADULT TO ASSIST WITH THIS ASSEMBLY (INDEALLY 4 ADULTS NEEDED FOR LIFTING)

Figure 4

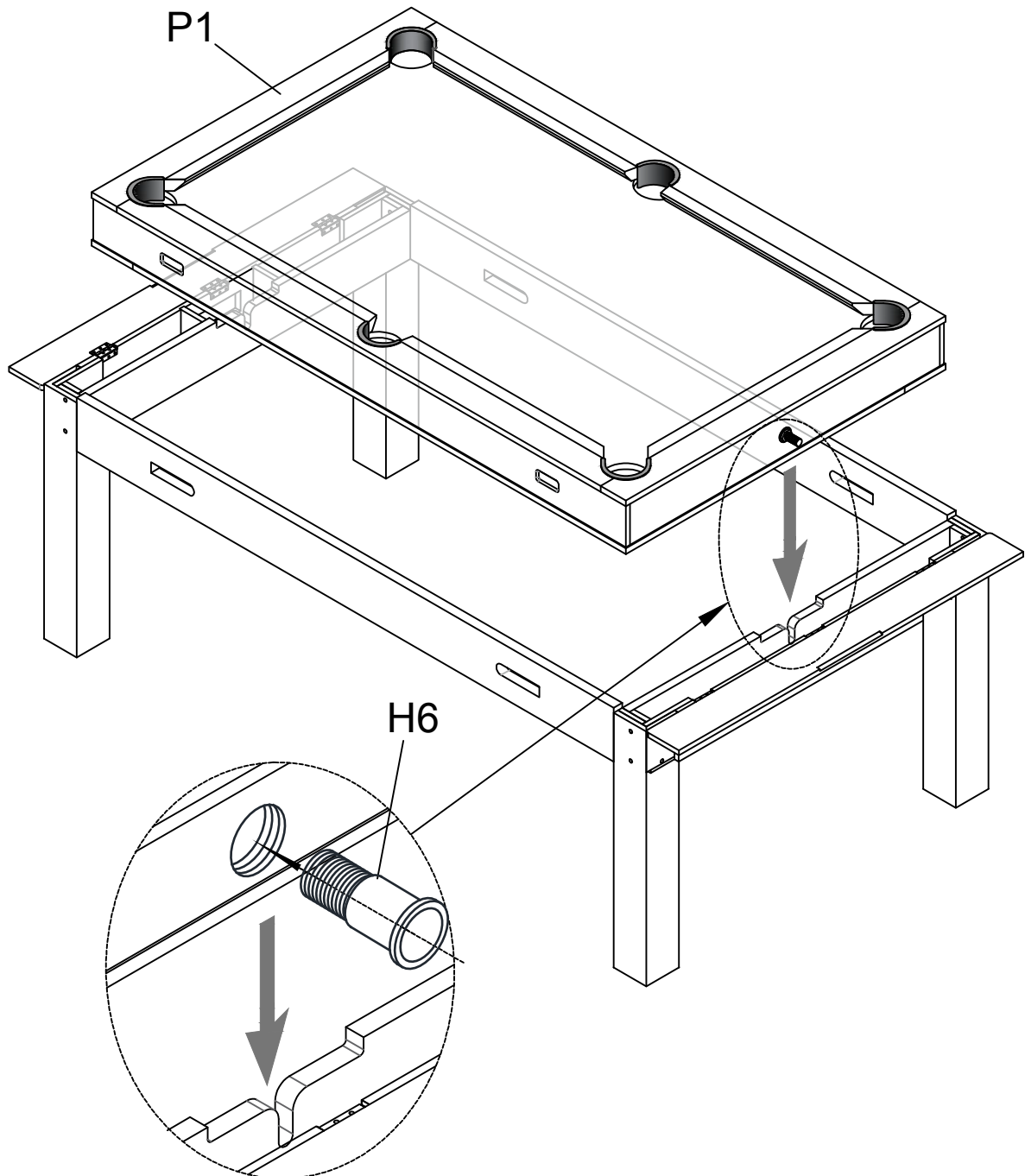

ASSEMBLY INSTRUCTIONS

WARNING: TWO ADULTS NEEDED ASSEMBLE POOL TABLE

Figure 5

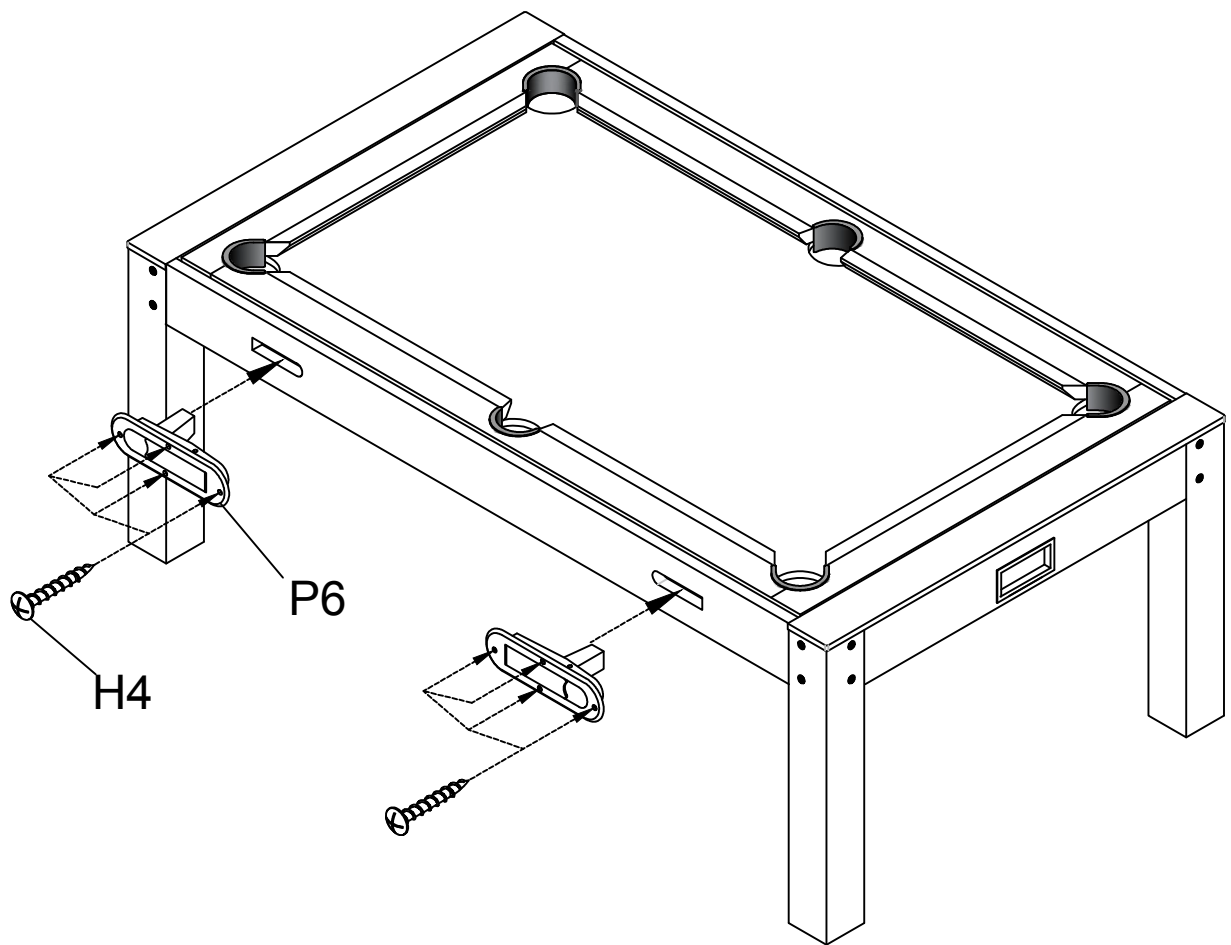

ASSEMBLY INSTRUCTIONS

WARNING: TWO ADULTS NEEDED ASSEMBLE POOL TABLE

Figure 6

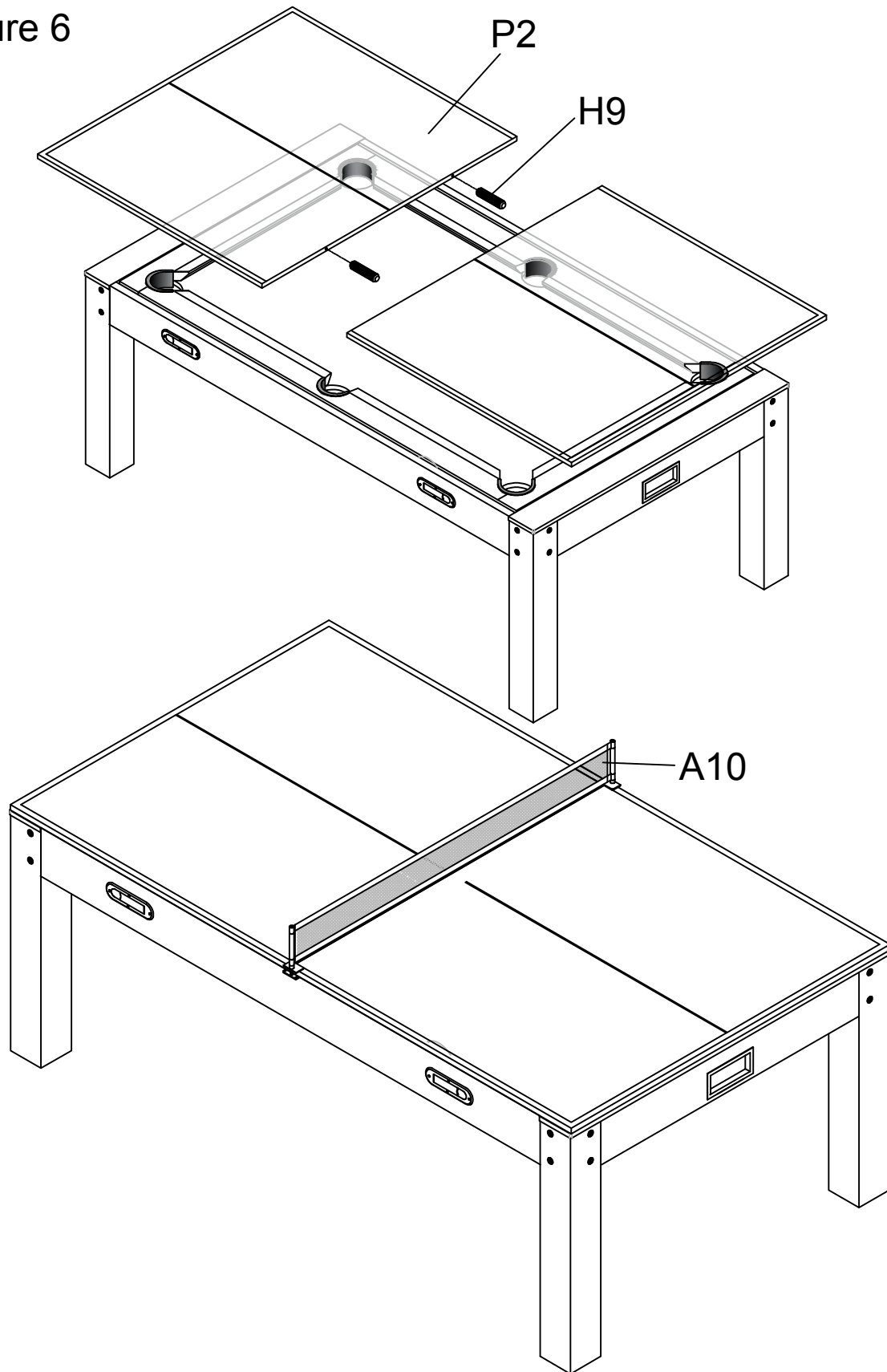

ASSEMBLY INSTRUCTIONS

Figure 7

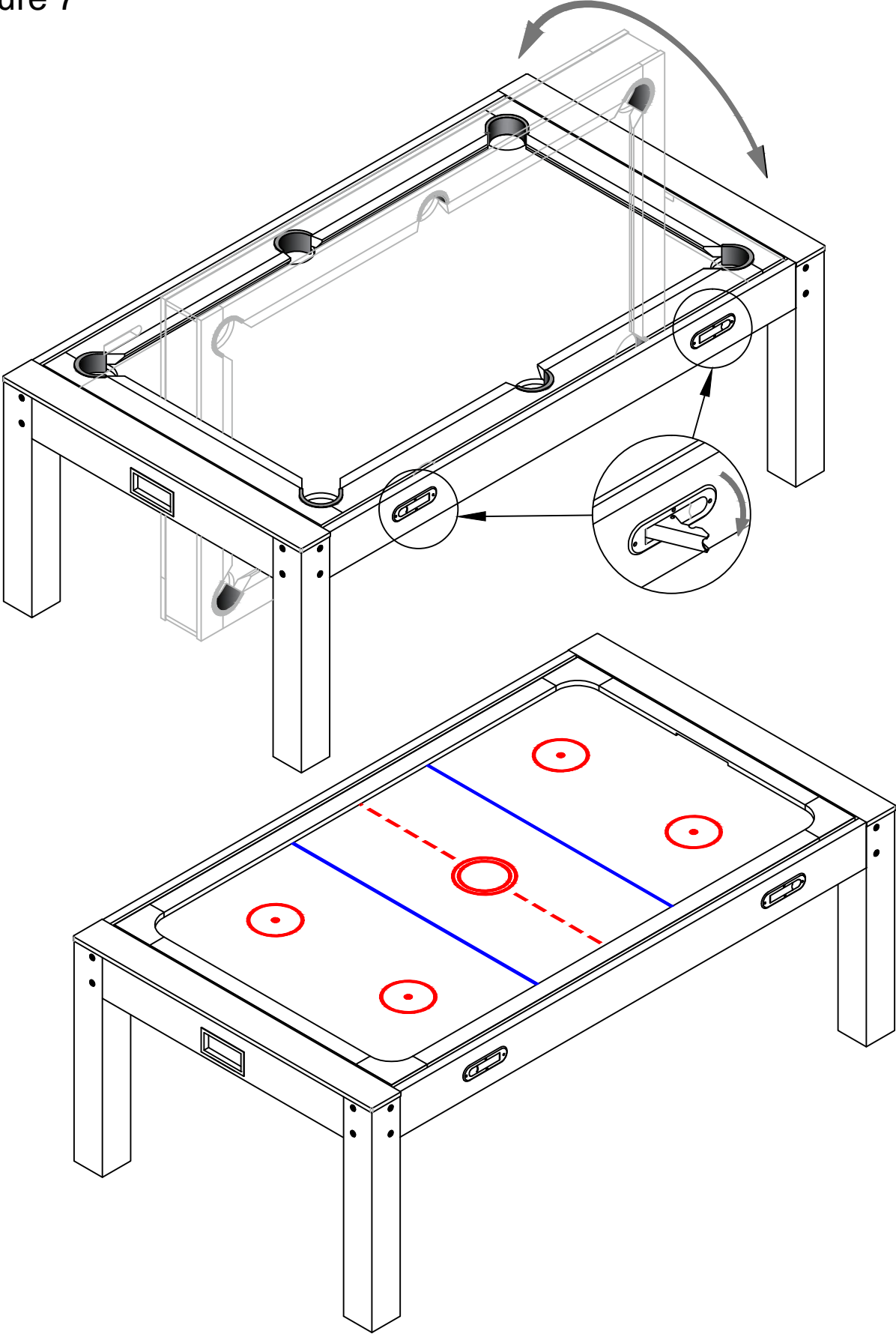

INSTRUCTION FOR THE 7FT REVOLVER 3-IN-1MULTIGAMES TABLE

Please keep these instructions for future reference. Adult assembly required.
This table is not a toy & is intended for use by or under the supervision of adults.

Tool required

Philips Screwdriver-not included

Standard(flat head) Screwdriver-not included

Allen Key-included

Note:electric screwdrivers may be helpful during assembly however please set a low torque & use extreme caution.

Assembly Tips

Make sure you understand the following before you begin to assemble your game table.

1. READ THIS MANUAL all the way through before beginning assembly.
2. Some drawings or images in the manual may not look exactly like your product.
3. you will need a second adult to assist with this assembly (indeally 4 adults needed for lifting).
4. Save all packing materials until the parts have been inspected & the table is assembled

Unpack the pieces

1. Lay the box a flat surface (the floor). You may want this near your area of assembly.
2. Unpack the boxes & parts bags. inspect & count the parts. The parts identifier page can be uses to record your results.