

ASSEMBLY INSTRUCTION

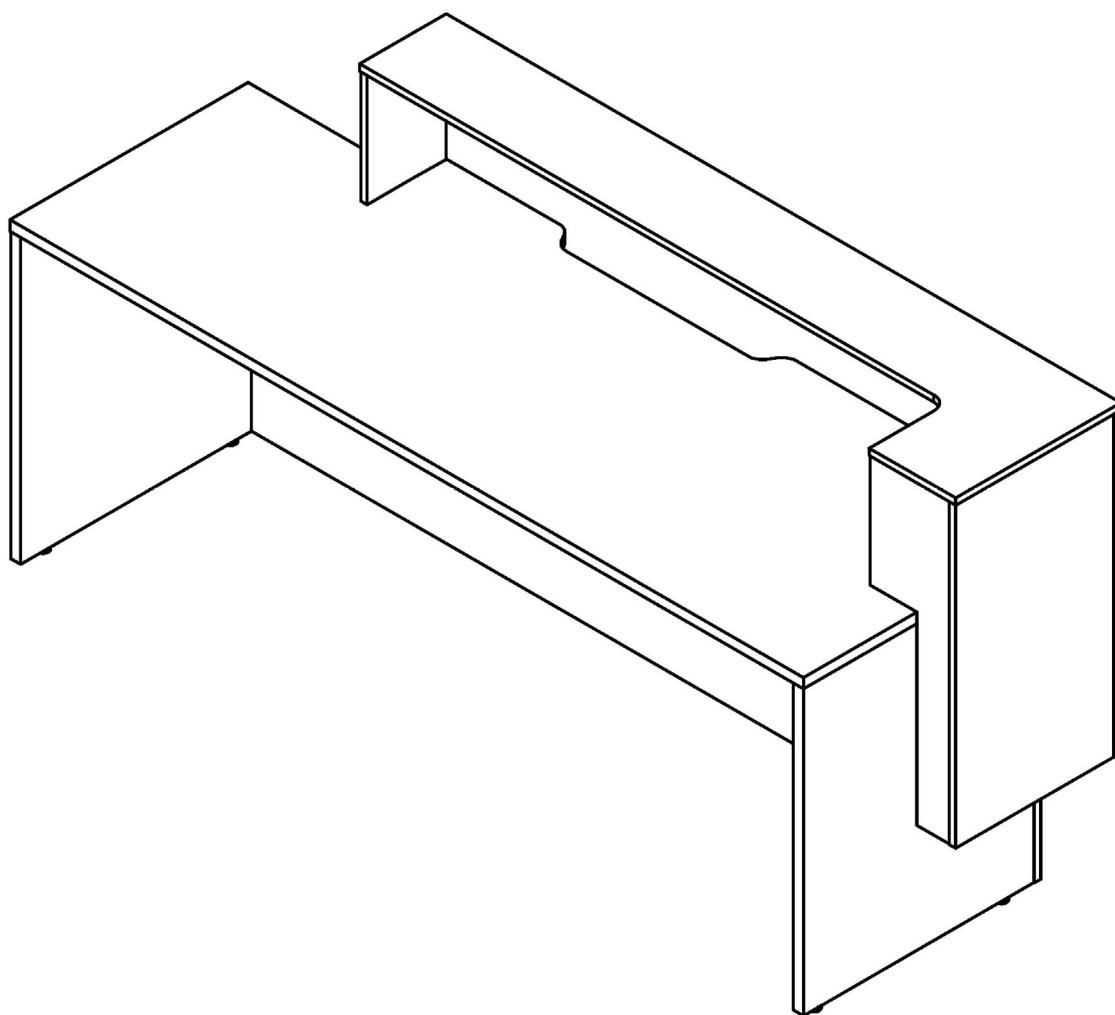

Dear Customer,

Thank you for choosing us. Before you begin assembly, check that you have all the parts and hardware shown on this page. If there is any item missing, please circle the item, indicating quantity required and send picture to us. We will arrange replacement at first time.

If feel question in assemble, Please feel free to ask us. Customer satisfaction is our prime.

Your order means a lot to us!

Thank you

TOOLS NEEDED

Crosshead screwdriver
Flat-head screwdriver



PARTS LIST

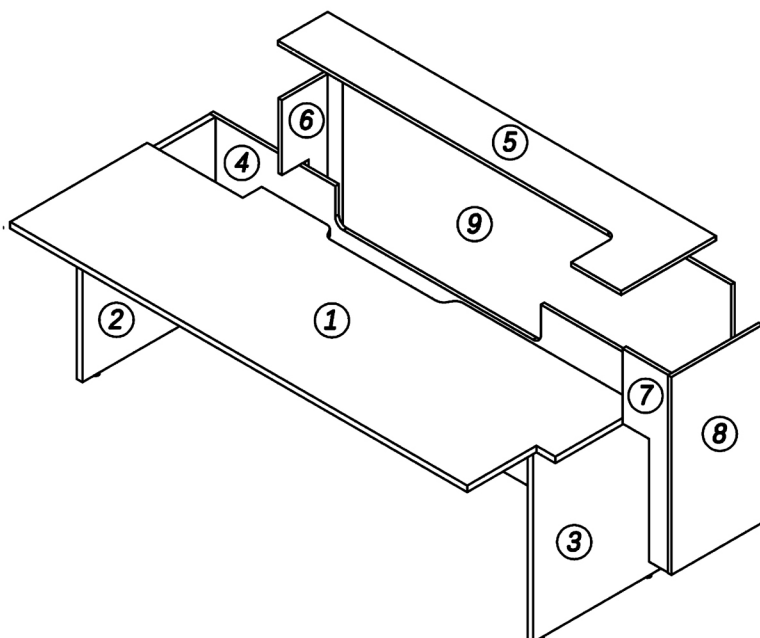

- ① worksurface panel
- ② left side panel
- ③ right side panel
- ④ modesty panel
- ⑤ top panel
- ⑥ left side cover panel
- ⑦ front side cover panel
- ⑧ right side cover panel
- ⑨ back cover panel

HARDWARE

A: Cam Lock
Φ 15*11mm



33 pcs

B: Cam Bolt
Φ 6*35mm



33 pcs

C: Wooden Dowel
Φ 8*30mm



18 pcs

D: Glider
M8*25mm

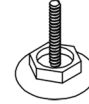

4 pcs

E: Glider
M6*25mm



2 pcs

F: Screw
M6*40mm



4 pcs

G: Screw
M 6*12mm



8 pcs

H: Connection
70*30mm

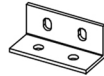

2 pcs

I: Plug(low)
Φ 15mm



23 pcs

J: Plug(deep)
Φ 15mm



10 pcs

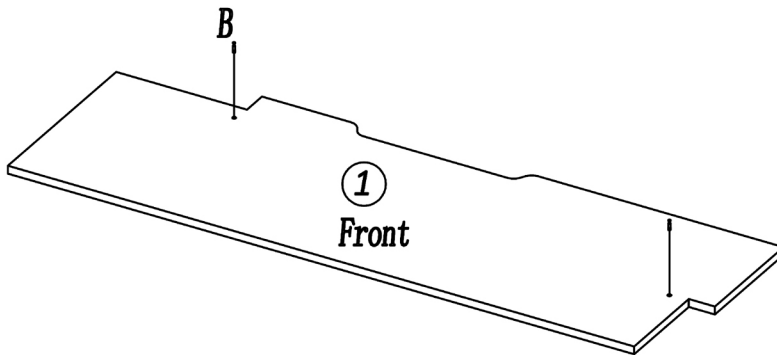

STEP 1

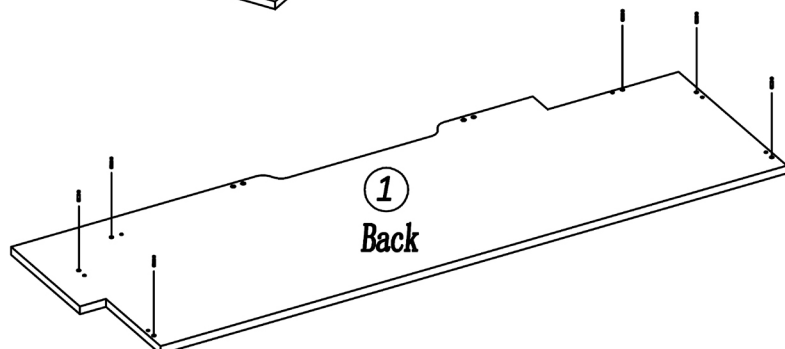

B  8 pcs



STEP 2

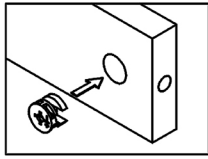

- A**  5 pcs
- C**  4 pcs
- D**  2 pcs

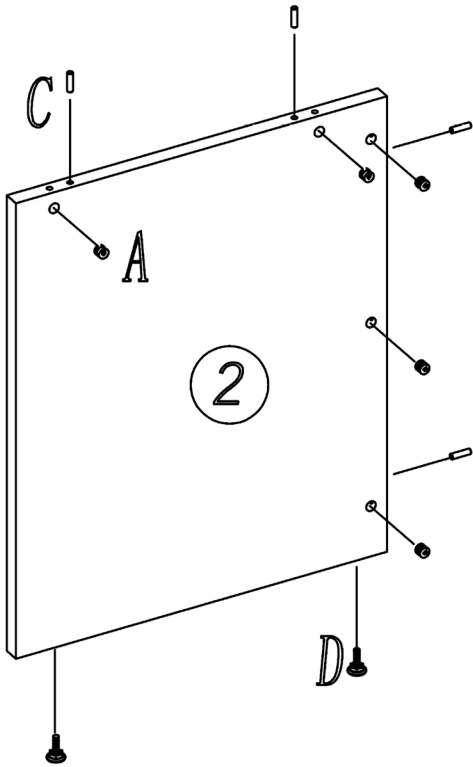

Direction of arrow to the side hole.



STEP 3



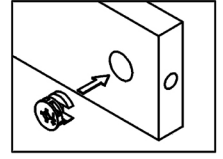

- A**  5 pcs
- C**  4 pcs
- D**  2 pcs

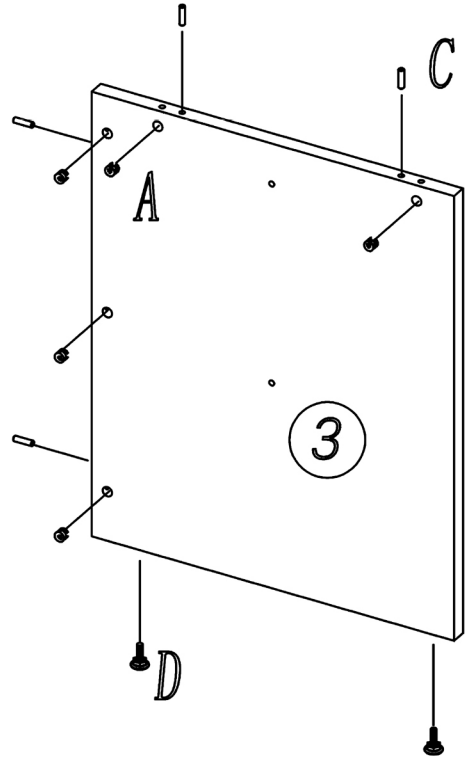

Direction of arrow to the side hole.



STEP 4

- A**  2 pcs
- B**  6 pcs
- C**  2 pcs
- E**  2 pcs

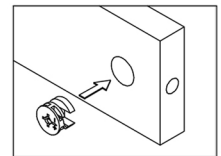
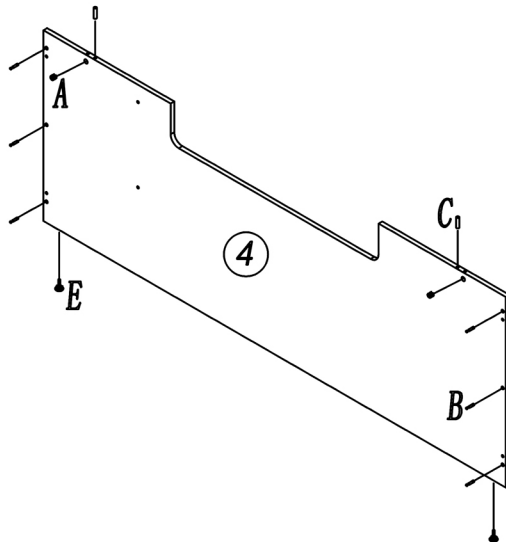

Direction of arrow to the side hole.

STEP 5

B  9 pcs

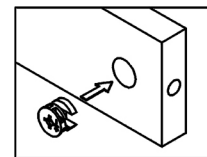

Direction of arrow to the side hole.

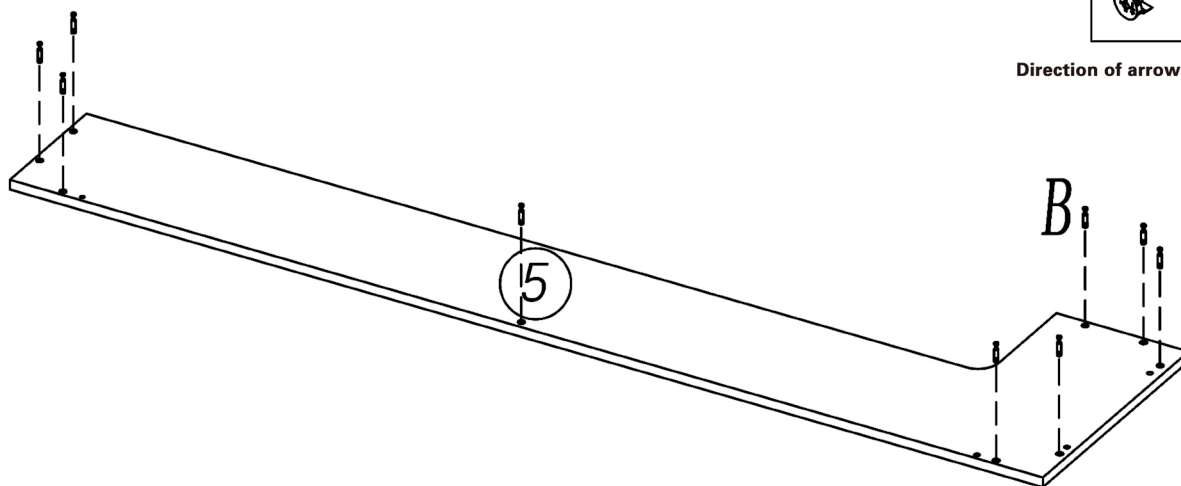

STEP 6

A  6 pcs

C  2 pcs

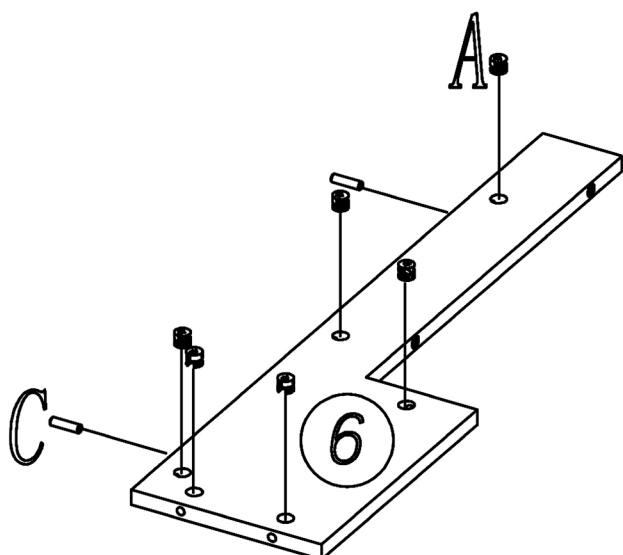



STEP 7

A  6 pcs

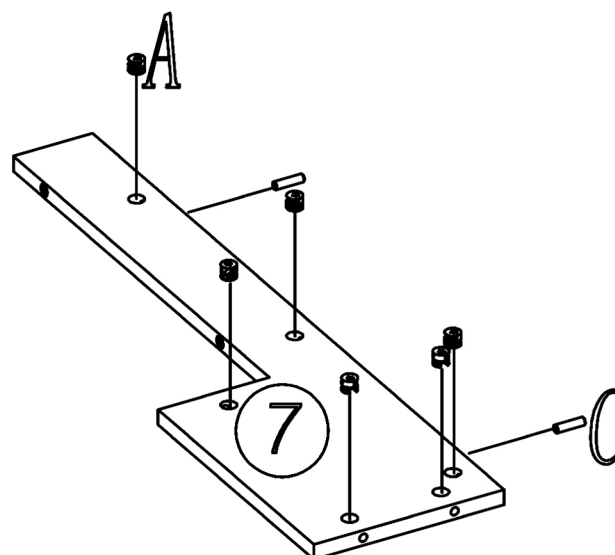
C  2 pcs



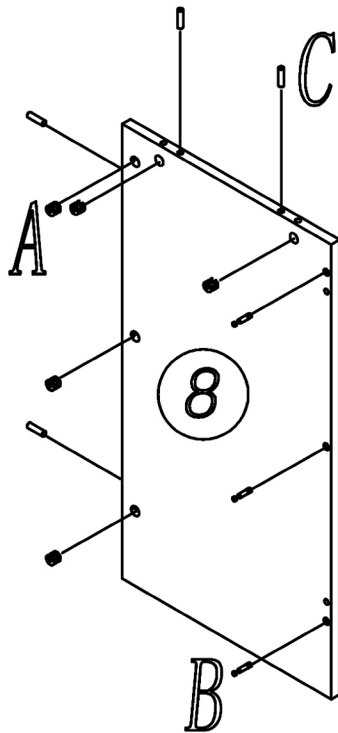

STEP 8

- A**  5 pcs
- B**  3 pcs
- C**  4 pcs



STEP 9

- A**  3 pcs
- B**  6 pcs

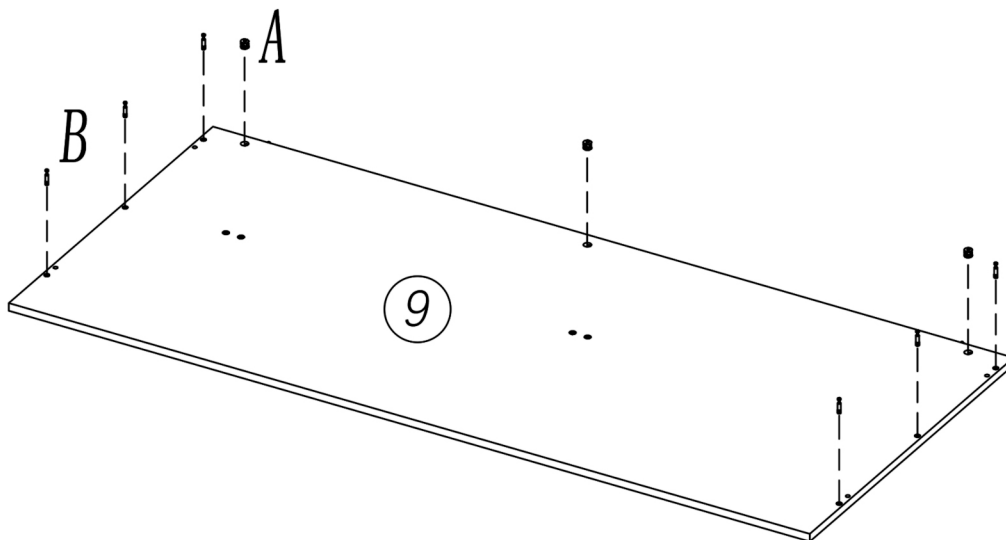

STEP 10

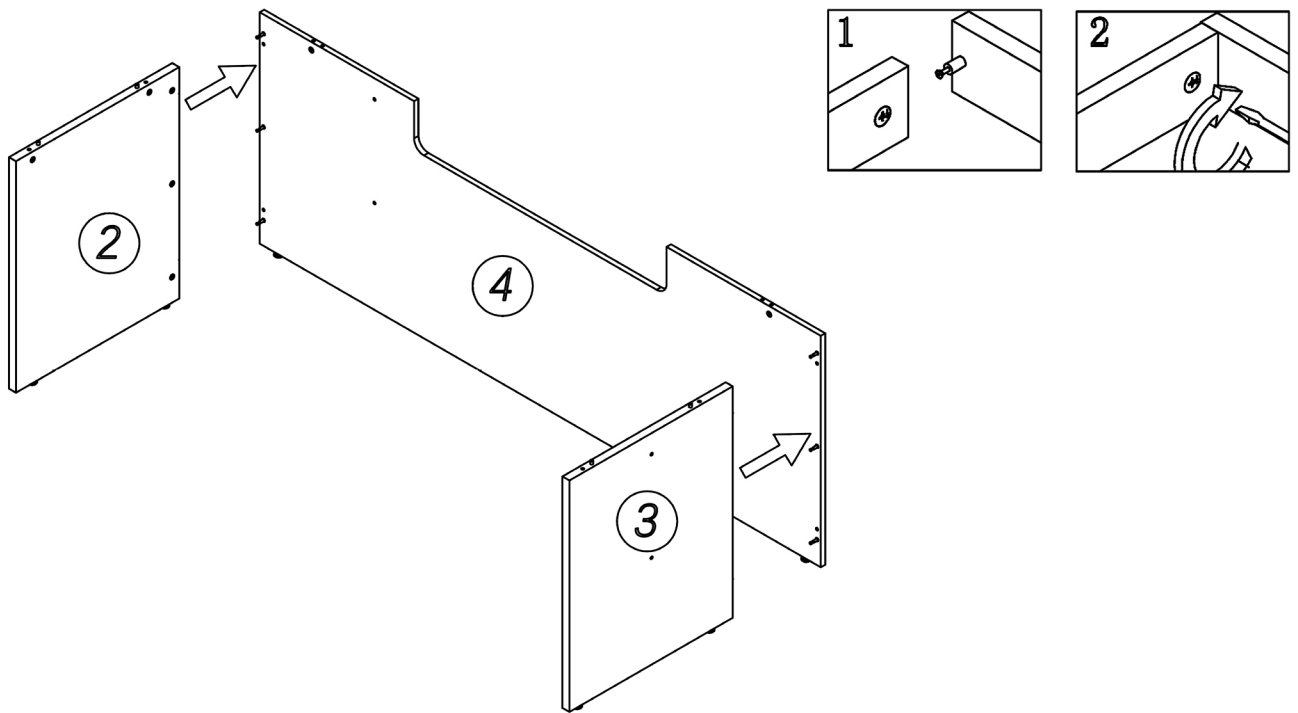

STEP 11

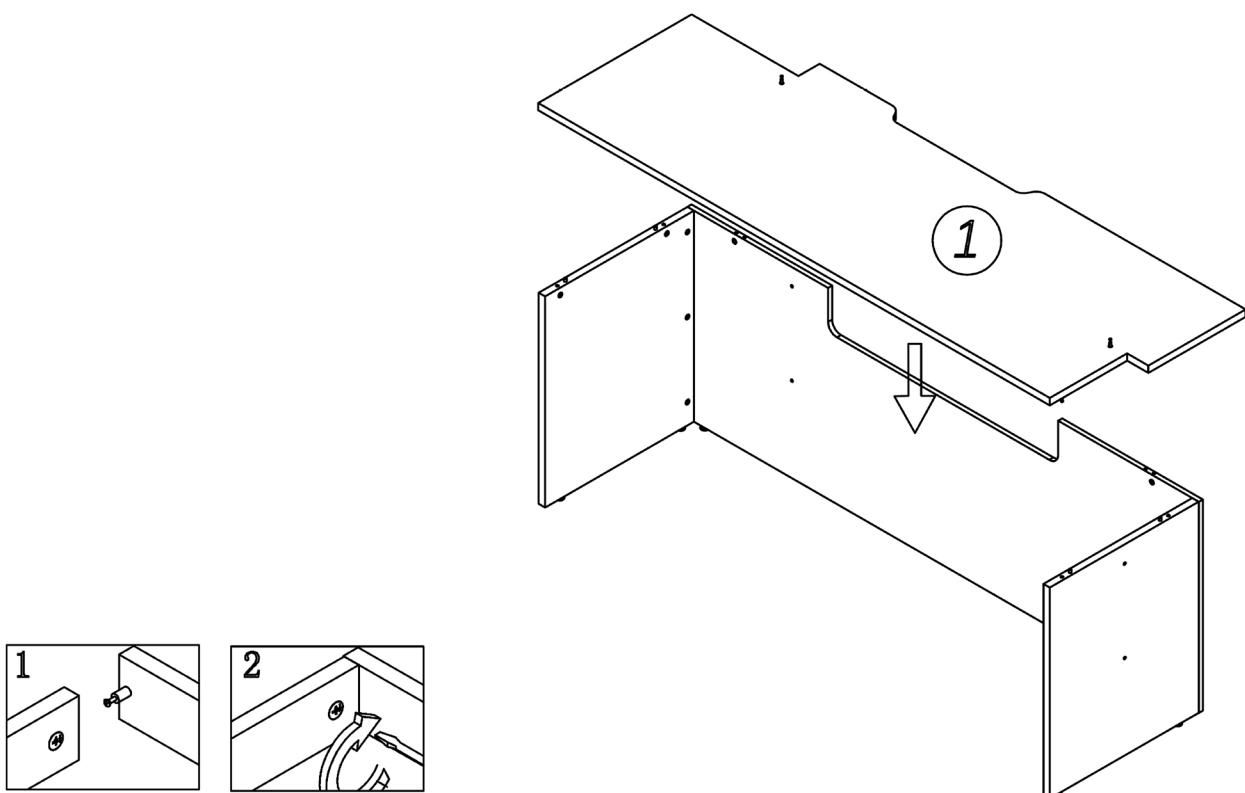

STEP 12

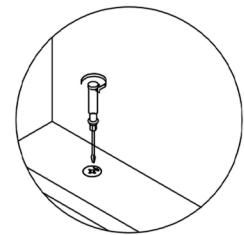
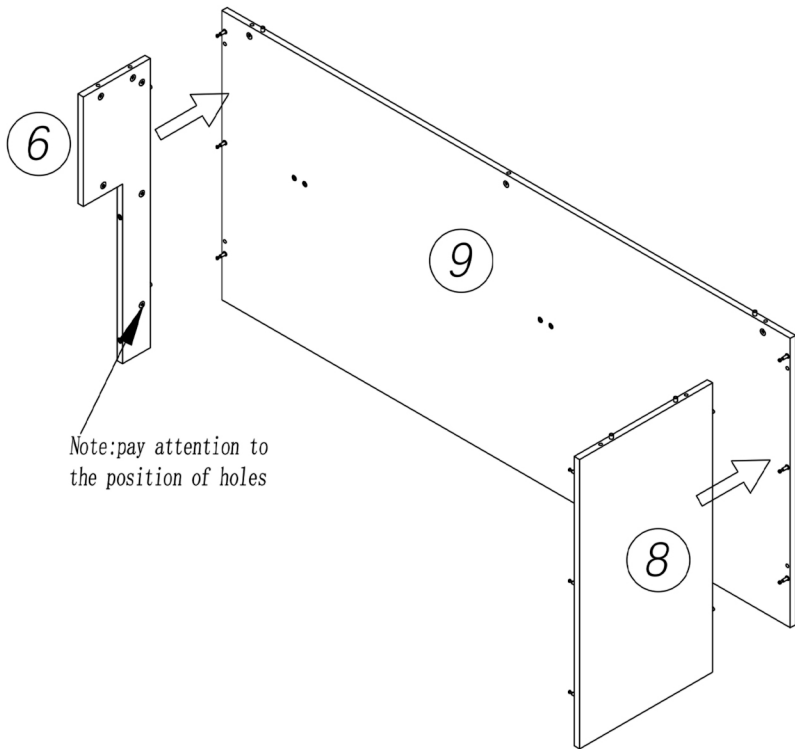

Remember to lock the Cam Lock

STEP 13

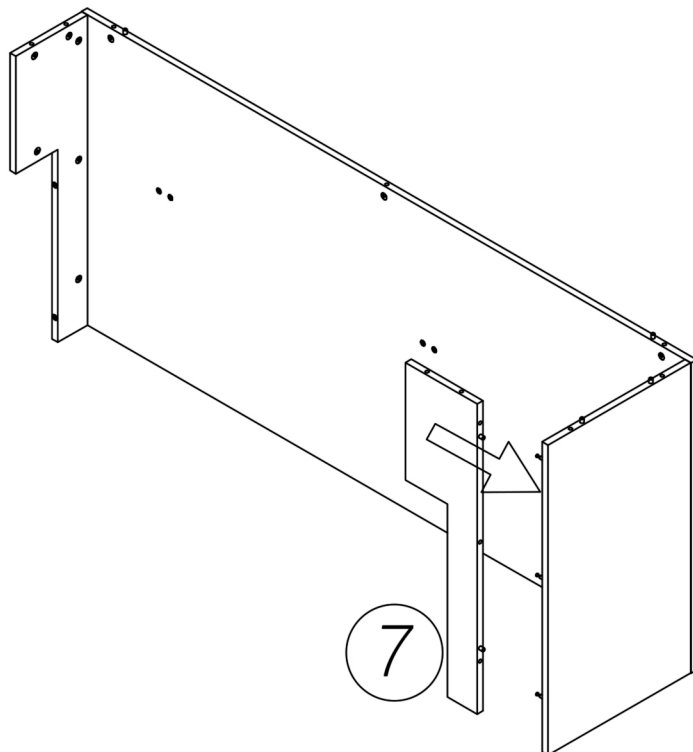

STEP 14

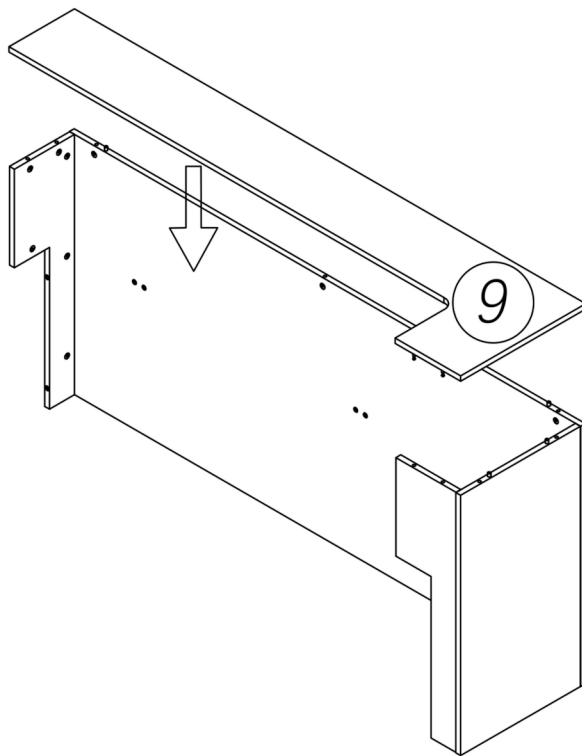

STEP 15

F 4 pcs

G 8 pcs

H 2 pcs

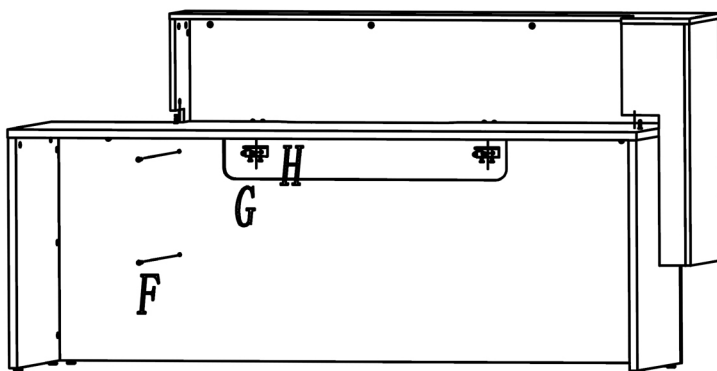
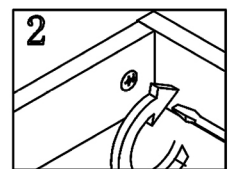
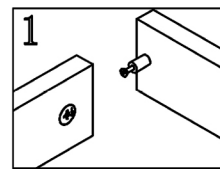

Angle 1

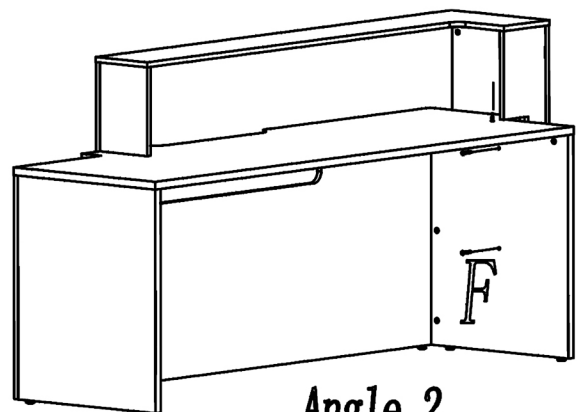

Angle 2

STEP 16

I 23 pcs

J 10 pcs

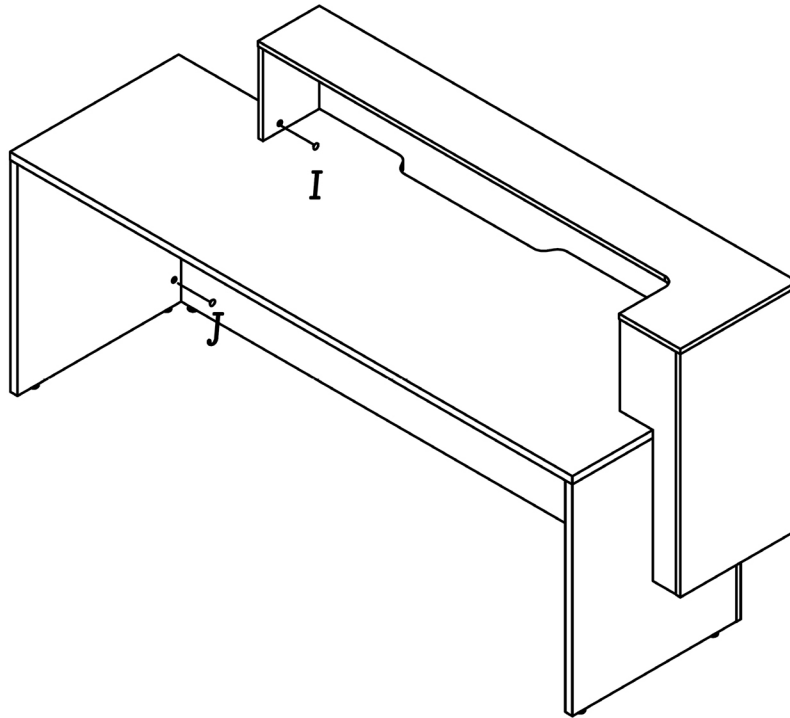

Thank you for your recent order.

We strive to provide customers with great services and satisfaction.

If any questions, please contact us.

Our customer support team is ready to help!