

HAPPINESS HAPPINESS INSTALLATION

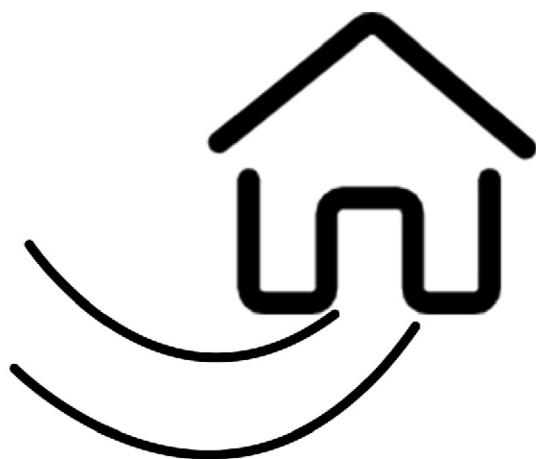

CAUTION

Parts are placed at the bottom of the product.

- If you have any questions with the product, please contact us by:
- **Email: customerservice@zoy-living.com**
(we will reply to you within 24 hours)





Assembly Instructions



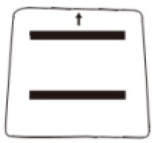

001T



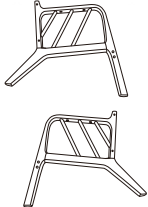

Your accent chair comes packaged in one box. Carefully remove all of components from the packaging and set aside for assembly.

CAUTION:
DO NOT use any sharp objects to open plastic wrapped components as damage to product or components may result.

Package Contents

				
A*1	B*1	C*1	D*1	E*2

				
F*1	G*8 M8*60	H*2	I*4	J*1

			
K*2 M8*70	L * 1	M*4 M6*35	N*2

Step 1:

put the frame into the foam cushion

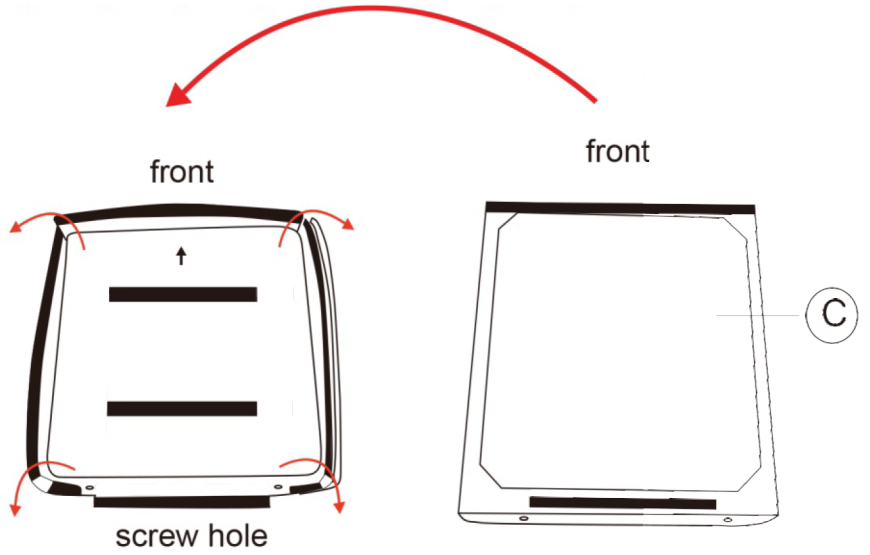
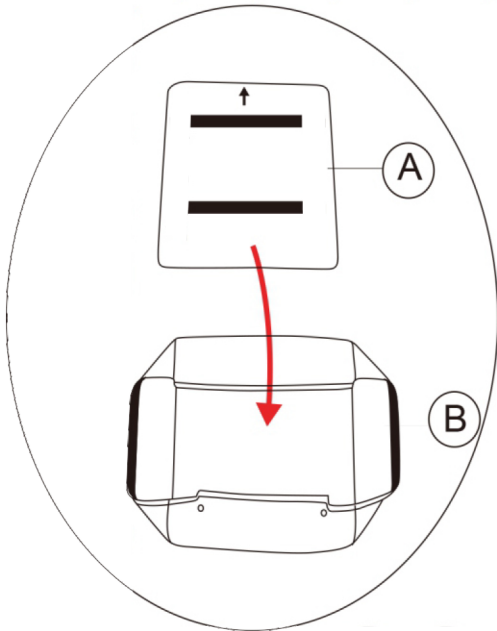

Tips: hole to hole please

Step 2:

Tips: front first

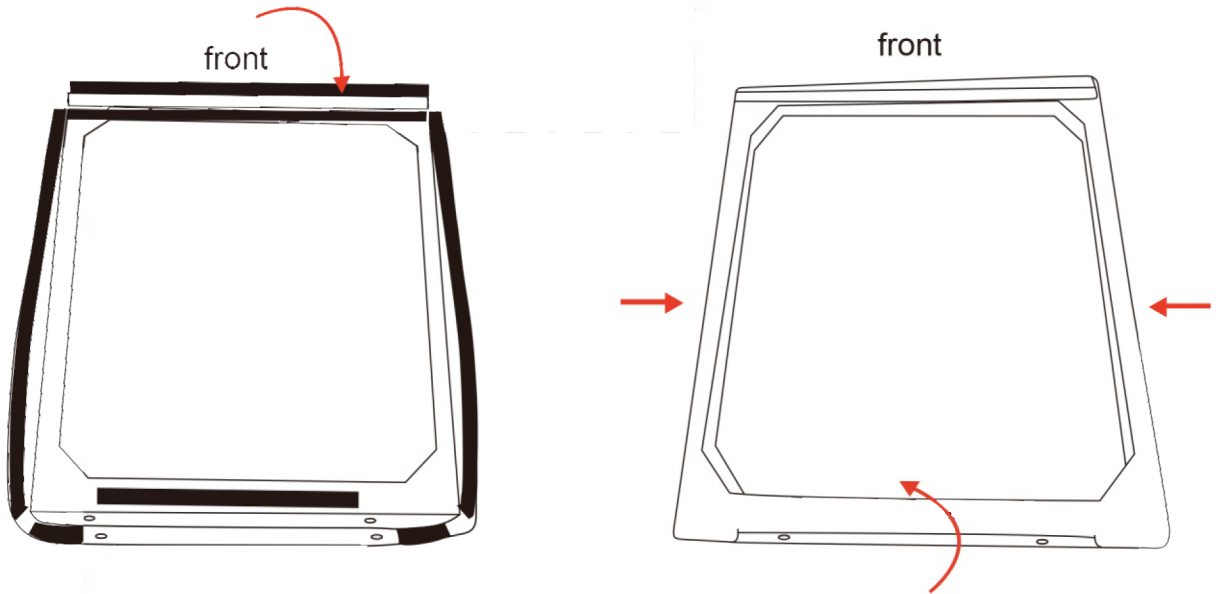

Step 3:

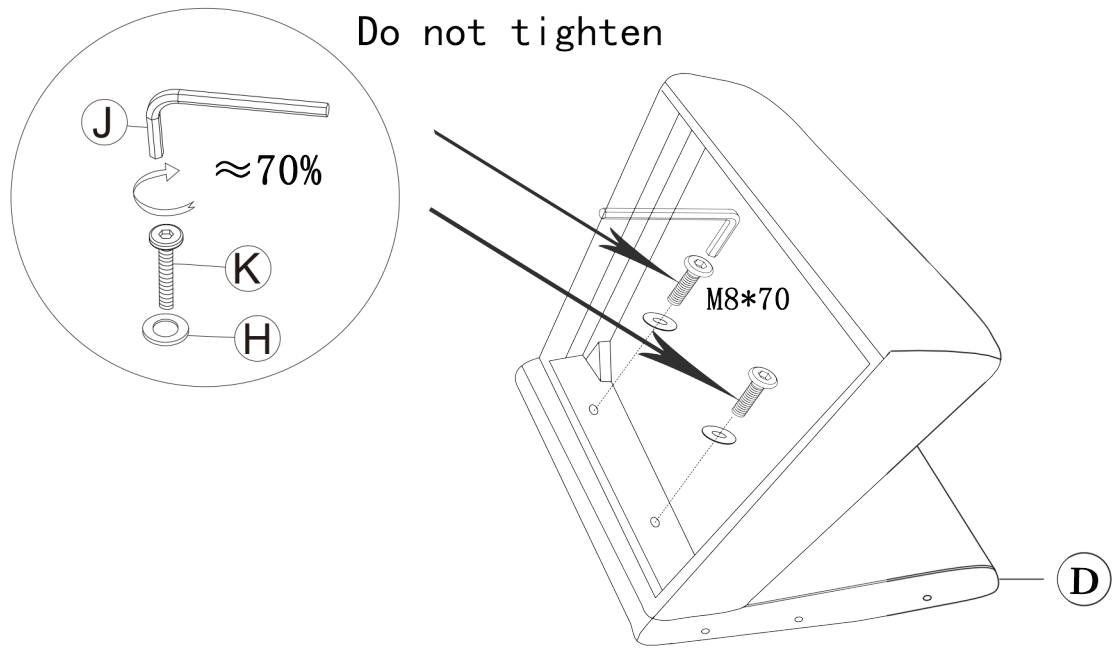

Step 4:

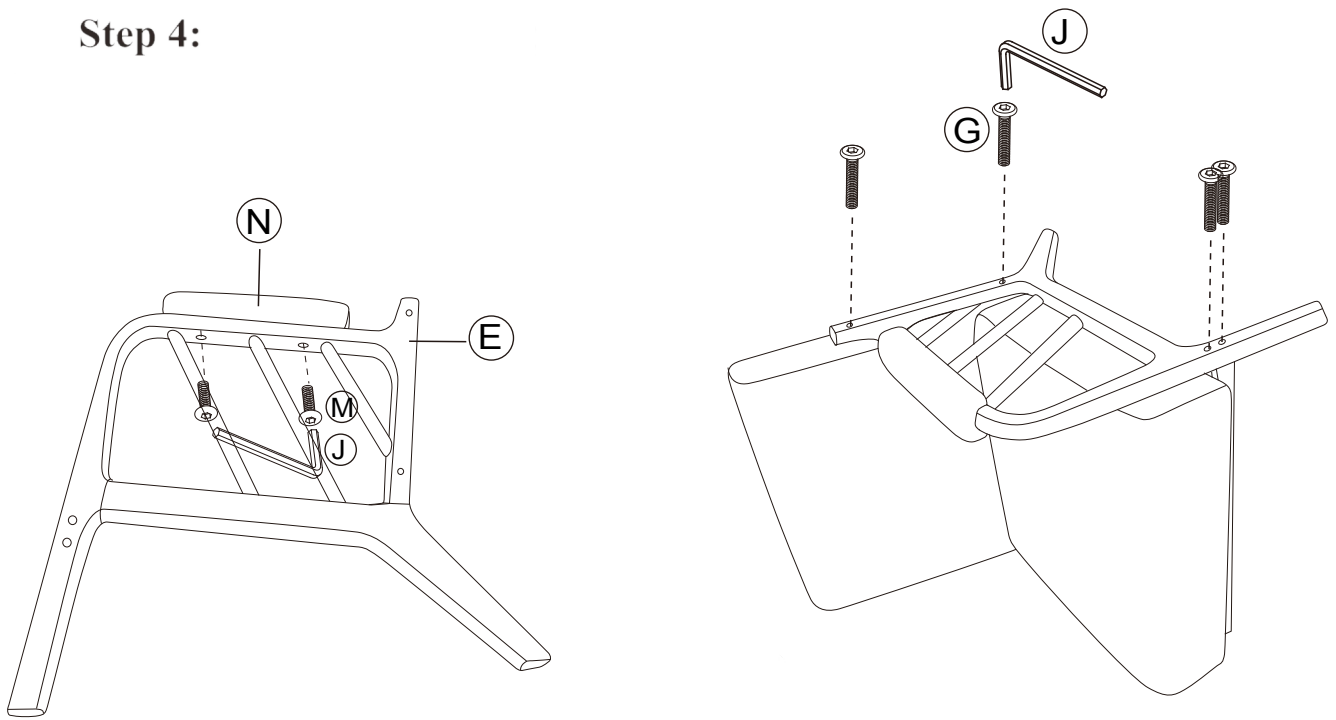

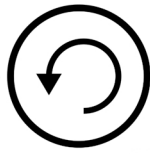

Revolve

Step 5:

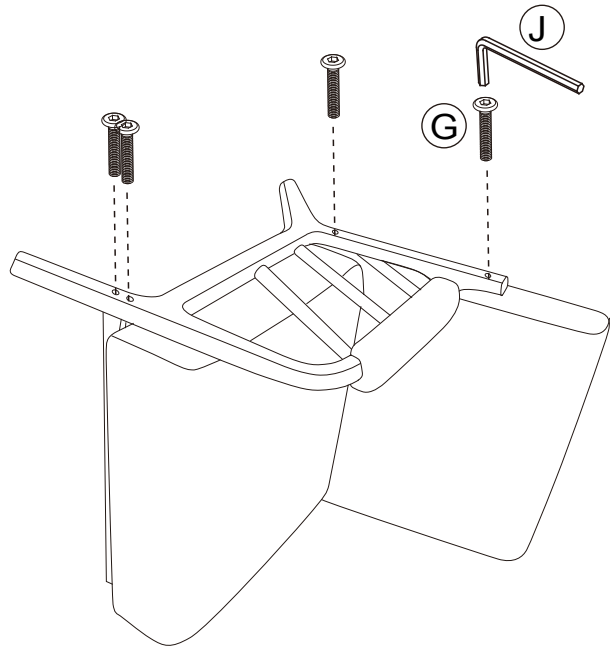
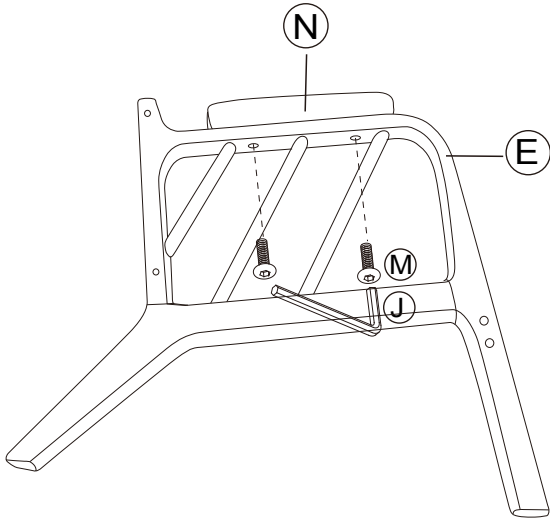

Step 6:

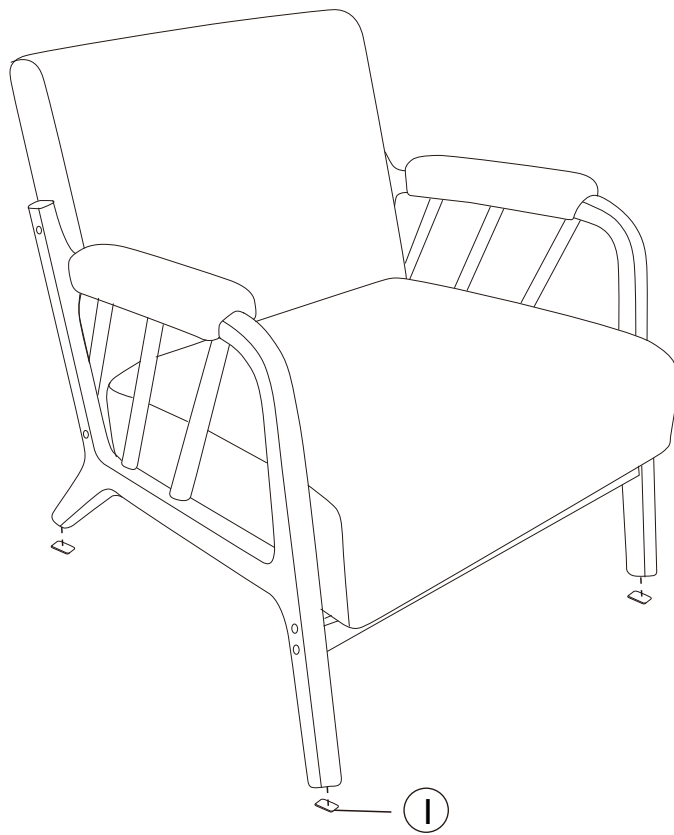

Step 6:

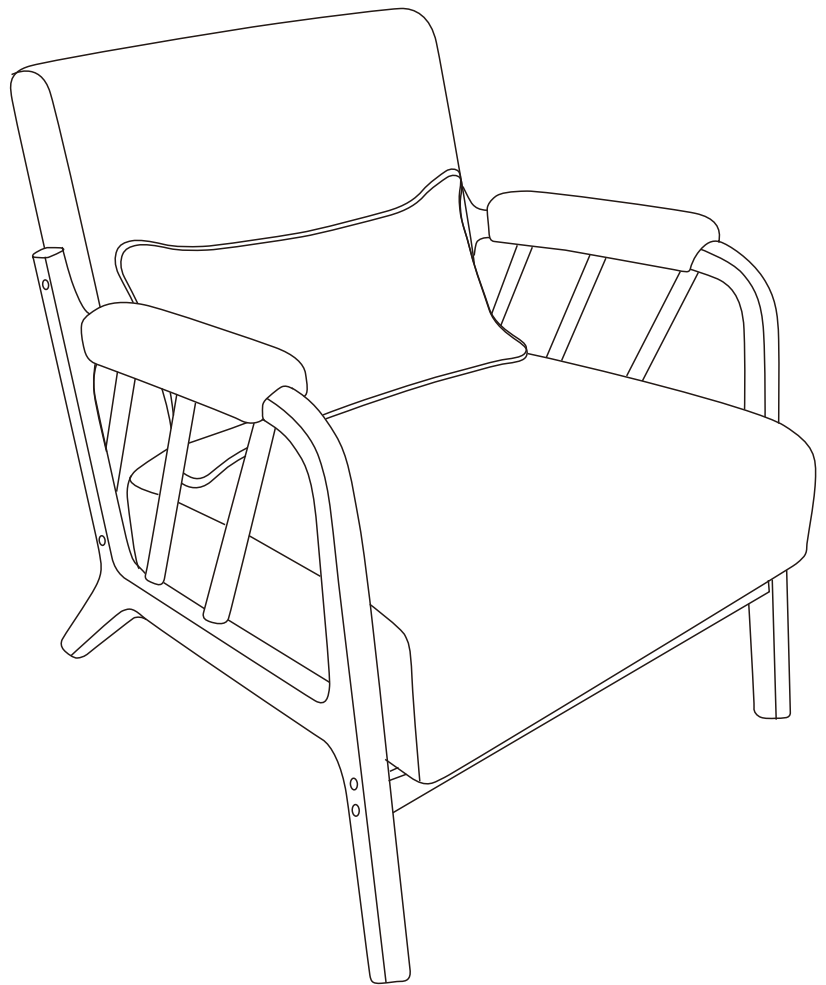
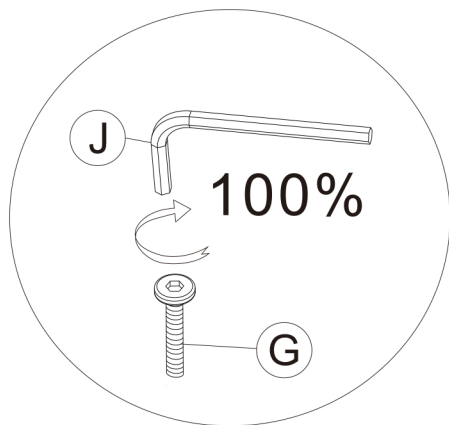
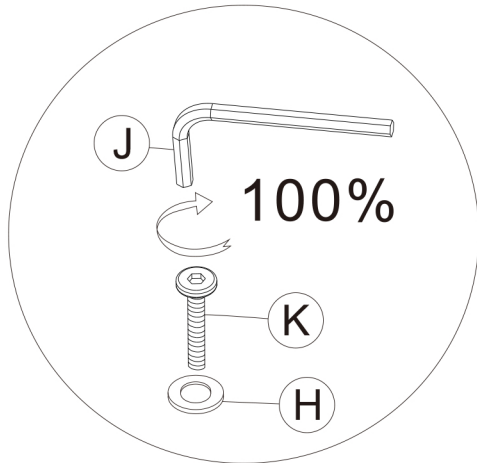

Screw tighten

ATTENTION!!

Bolts may loosen during normal everyday use. They should be periodically inspected and re-tightened to prevent damage or injury. Always check to ensure that all hardware is kept tightened.

Warnings

1. Please check if the components of the chair are all included and can be used normally.
2. Assemble all components according to the instruction correctly before you connect the chair to the power.
3. Please DO NOT sit on the armrests or footrest to eliminate the risk of tipping over.
4. If the chair is damaged or doesn't match the website description, please send clear pictures of the product and label of the carton to our service team for further help.
5. If the accent chair doesn't work, you may try the following measures for self-checking firstly:
 - a) Check if all the cables are connected;
 - b) Check if the light of transformer is on.

If the chair still doesn't work, please feed the information back to our customer service in time and we'll help you solve the matter as soon as possible.

6. If you have any questions with the product, please contact us by:

Email: customerservice@zoy-living.com (we will reply to you within 24 hours)

