

Assembly Instructions

820332 End Table - Light OAK
820335 End Table - Smoked OAK

Product Issues? Please Call Us Before Contacting Your Retailer At 1-800-549-3300

Email customerservice@mshome.co, or visit www.mshome.co

**We can help with Assembly Issues, Part Requests, Damages, & All Other Product
Related Questions**

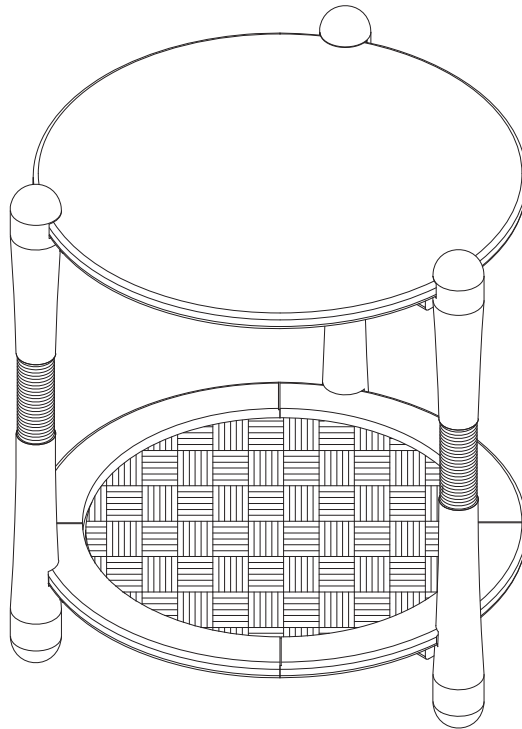

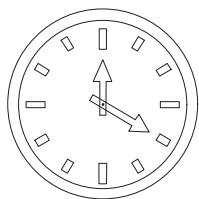

20 min

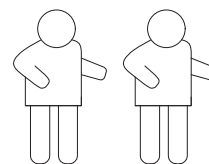

Two People Required
for Assembly

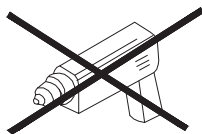
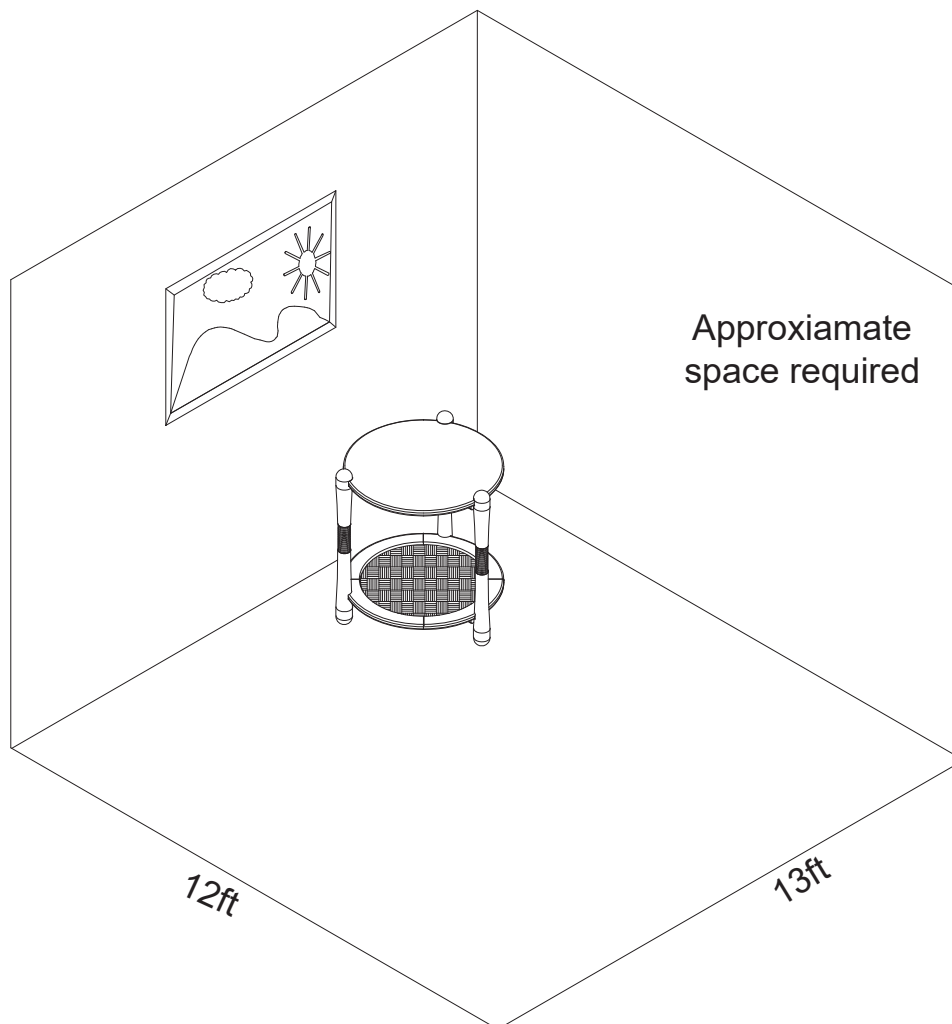

Do Not Use Power Tools

Parts Included:

- (C1) Top Panel x1
- (C2) Legs x 3
- (C3) Bottom Frame x 1

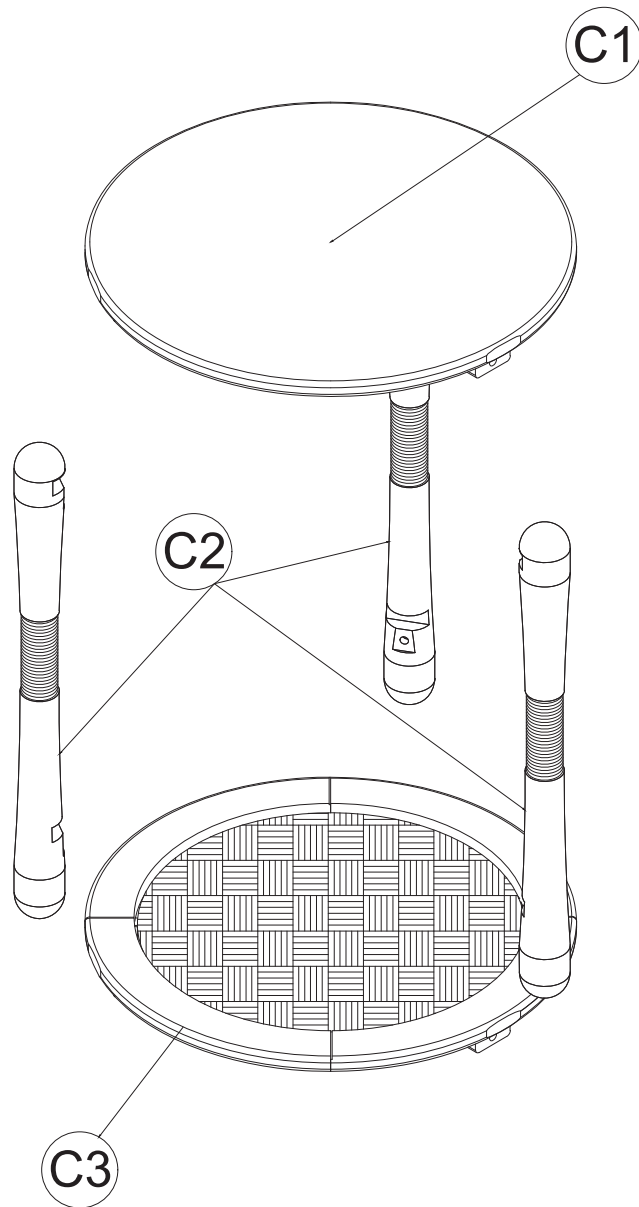

✓ Hardware Pack:

A

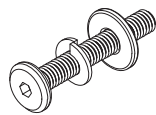

Ø6 x 35 (mm): 6pcs

B

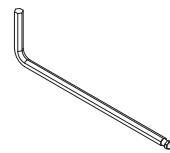

Ø4 : 1pc

1

A x 2



Ø6 x 35 (mm)

B



Position an object at least 2" high beneath the top panel before continuing with the assembly
In this step, assemble only the two legs first, following the illustration.

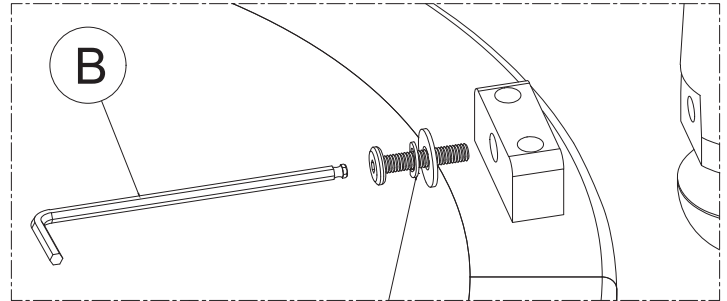
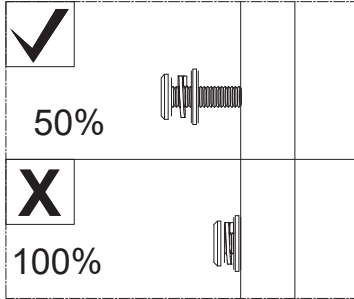

Do not fully tighten the bolts at this stage
until all the parts are in position

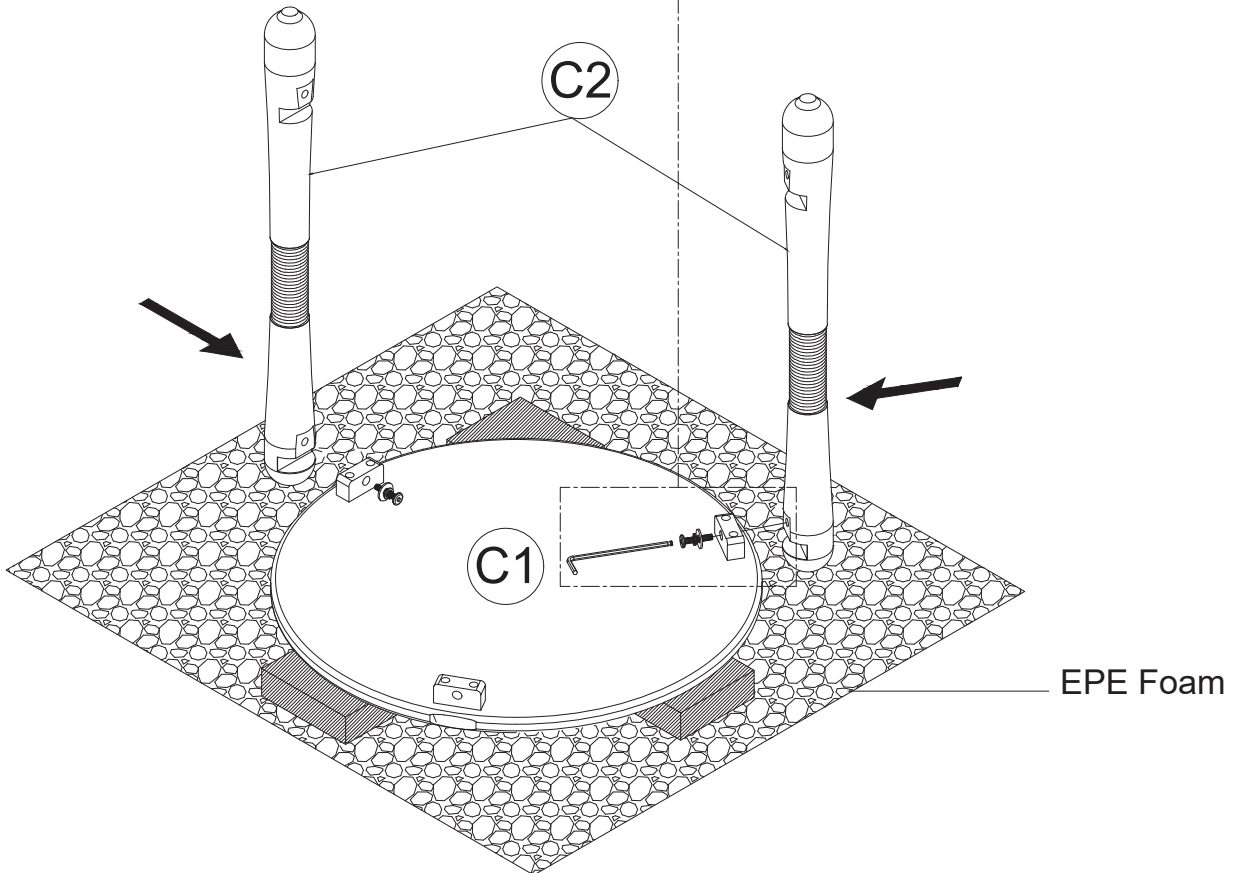

2

A x 2



Ø6 x 35 (mm)

B

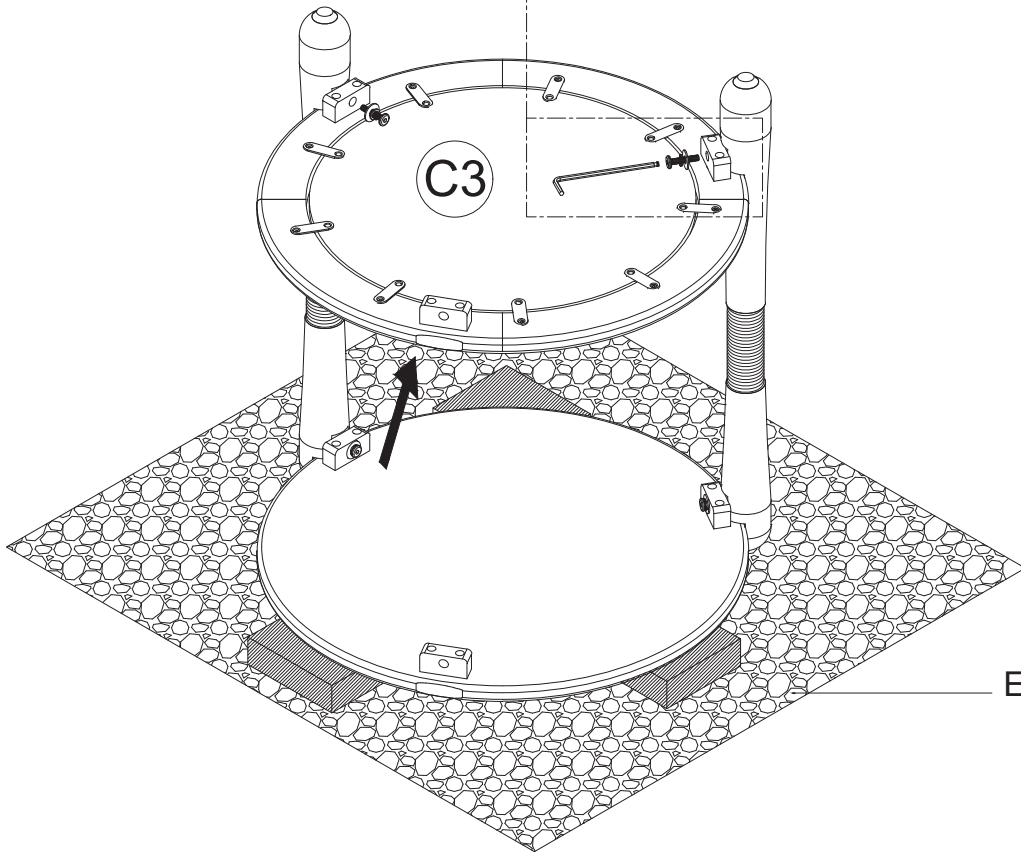
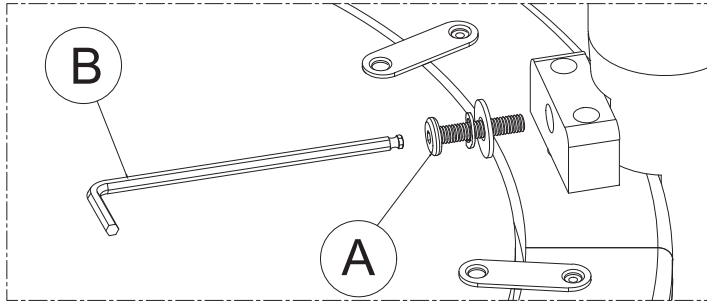

EPE Foam

3

A x 2



Ø6 x 35 (mm)

B



Fully tighten all bolts to complete the table assembly

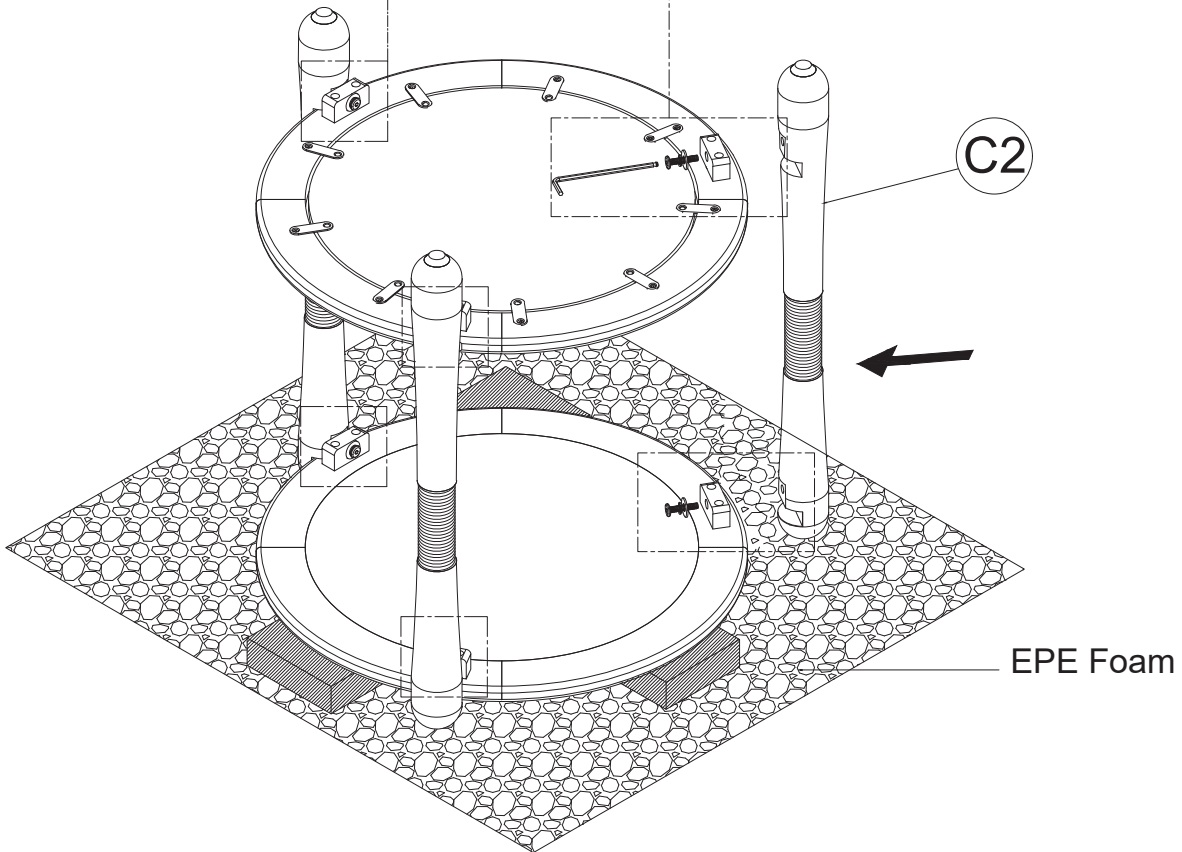
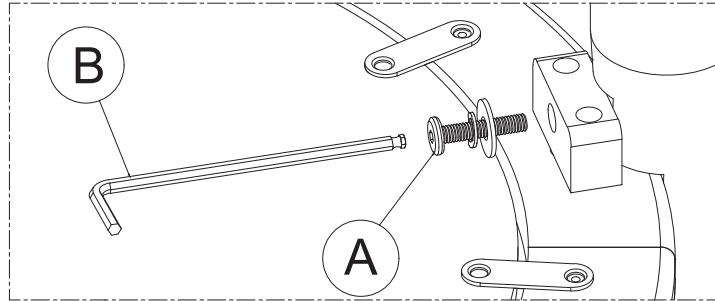
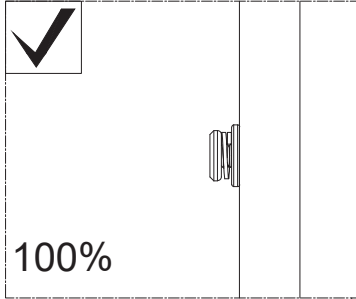

4

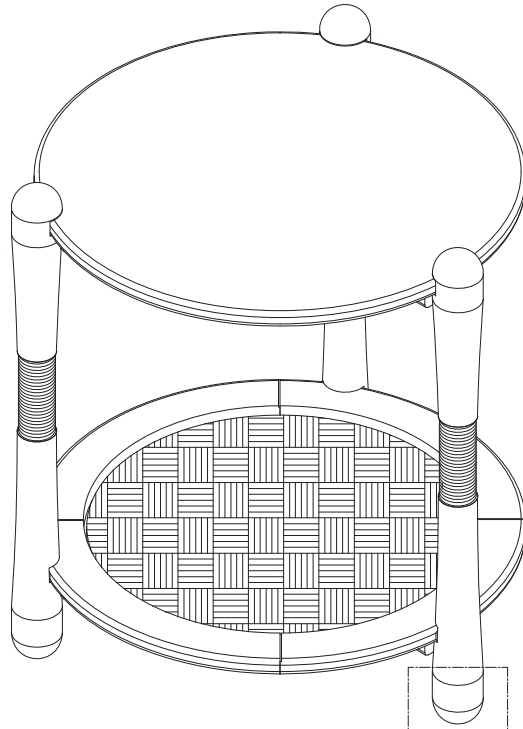

Adjustable leveler

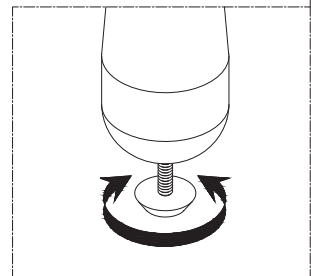

Use the leveling base to attach to the legs for balance.
If the table is rocking, adjust the adjuster until the condition gets better.



Replacement Part Form

Have an issue? Need a replacement part?

Please E-mail us before contacting your retailer, we will be happy to fix your issue.

This process will be hassle free! We will replace your part for free!

Please follow these easy steps below.

You will need to E-mail *Martin Svensson Home* Customer Service: Customerservice@mshome.co
(Please note it is .CO not .com)

Please scan or take a picture of this form filled out.

1. **Customer Name:** _____

2. **SKU# with issue:** _____

3. **Replacement Part # needed** _____

*Please reference the Assembly Instructions to identify needed part #'s

4. **Photos of the Damaged Part** (please include in the e-mail)

5. **Brief description of the part issue:** _____

6. **Proof of Purchase** (please provide a copy of your purchase receipt)

7. **Ship to Address:** _____

8. **Other contact information:**

Email Address _____

Phone # _____

*If possible, could you please provide the UPS or FedEx tracking from original shipment _____

*If possible, could you please provide the P.O. # - information found on back/underneath product _____

*If you have any other question, we are happy to assist with assembly questions or all other parts related questions. Thank you for your purchase!