

# ASSEMBLY INSTRUCTIONS

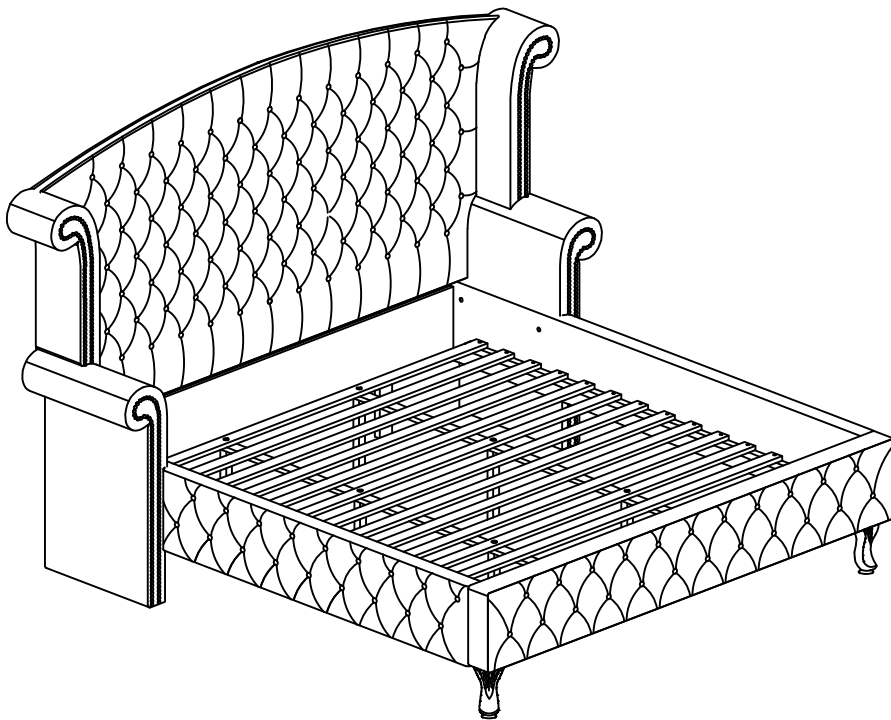

## TOOLS REQUIRED



Allen Wrench

(Included)



Phillips  
Screwdriver

(Not Included)



3 - People  
Recommended

## ASSEMBLY RATING

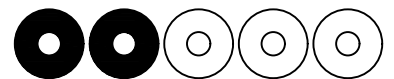

EASY —————> DIFFICULT

The Assembly Rating is a 5-point system showing the level of effort needed to assemble a specific product.



## **CHECK BEFORE STARTING**

### **Are you missing anything?**

Double-check all parts, hardware and accessories listed on Page 6 are accounted for.

### **Check out our Quick Tips!**

We recommend reviewing the pre-assembly handouts. Even experts need a refresher now and then!

### **Should we send any replacements?**

Are there any irregularities or flaws in the parts? We can send replacements!

### **Prep Time!**

Please review the assembly instructions and all diagrams prior to assembling. Arrange parts as recommended on Page 7 and group identical hardware together to make assembling easier.

# PRE ASSEMBLY INTRODUCTION

We understand building ready-to-assemble furniture can be a challenging experience for some. To help avoid confusion, we have provided some helpful tips that may speed up the process.



## Teamwork

ALWAYS have at least two people to help with transporting and assembling the product to avoid potential injury and/or damage.



## Suitable Location

Assembling near the area of the intended location is highly recommended.



## Sufficient Space

Make sure you have enough space to move around during the assembly.



## Avoid Scratches

Use cardboard, blankets or a carpeted area while assembling furniture to prevent scratches.



## Flat Surface

Make sure the furniture rests on a flat and level surface with each leg evenly touching the floor.

# ASSEMBLY AND CARE ADVICE



**FAILURE TO FOLLOW THE GUIDELINES BELOW MAY RESULT IN INJURY AND/OR PROPERTY DAMAGE.**



Position each part correctly and insert screws or bolts into their respective holes.



Turn clockwise to tighten and only tighten when step is completed or when instructed to do so.



Use the appropriate hand tools or power tools for assembly. Select steps, such as tightening screws and/or bolts, may require hand tools to avoid causing damage during assembly.



Save the instructions and store any supplied tools for later maintenance.



After two weeks, check and tighten any loose hardware and repeat again every six months thereafter.

**IT IS THE USER'S RESPONSIBILITY TO MAINTAIN THE FURNITURE. THE HARDWARE MAY LOOSEN OVER TIME AND MAY CAUSE THE FURNITURE TO BE WOBBLY AND UNABLE TO SUPPORT ITS INTENDED WEIGHT CAPACITY. THIS MAY LEAD TO COLLAPSE AND MAY CAUSE SERIOUS INJURY.**

# BED



- Please keep instructions for future reference.
- Check the quantity and irregularity of parts and hardware before you start.

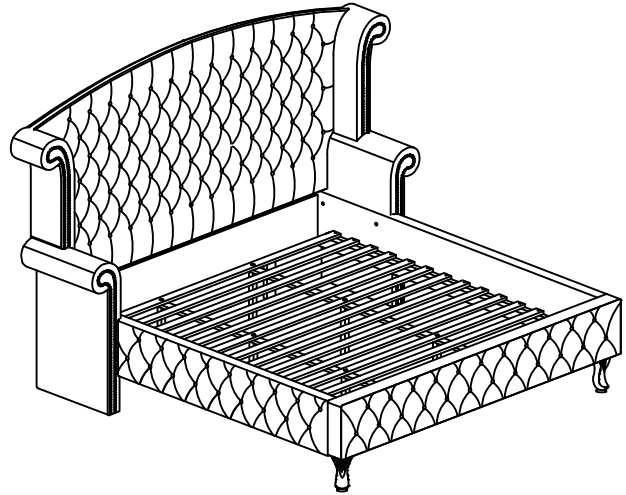

## PARTS

#1 1pc

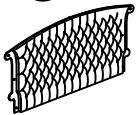

Headboard

#2 1pc

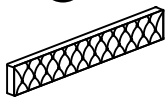

Footboard

#3 2pcs

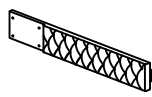

Rail (L&R)

#4 1pc



Headboard Panel

#5 2pcs



Ear Panel (L&R)

#6 2pcs

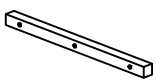

Support Bar

#7 2pcs



Headboard Support Leg

#8 11pcs



Slats

#9 3pcs



Slats Whit Hole

#10 2pcs



Center Rail

#11 2pcs



Footboard Leg

#12 6pcs



Slat Support Leg  
285x30x30mm

#13 2pcs



Center Rail Support

## HARDWARE

#A 1pc



Allen Wrench 4mm

#B 10pcs



Bolt Ø1/4" x 1-1/2"

#C 8pcs



Bolt Ø1/4" x 3-1/2"

#D 10pcs



Bolt Ø1/4" x 2-3/8"

#E 4pcs



Bolt Ø1/4" x 1-3/16"

#F 32pcs



Lock Washer Ø1/4"

#G 14pcs



Flat Washer Ø1/4"  
x19mm

#H 18pcs



Flat Washer Ø1/4"  
x25mm

#I 2pcs



Anti Slip Sheet

#J 4pcs



Screw M3 x 5/8"

#K 4pcs



Screw M4 x 25mm

#L 30pcs













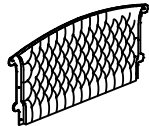









Screw M4 x 30mm

#M 6pcs

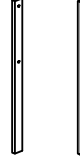
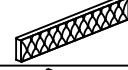
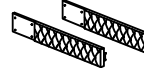
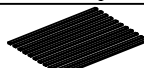

Screw M4 x 44mm

# CM7150Q/EK/CK is packed in 3 cases

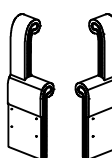
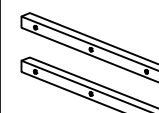
Carton	Disignation	Part		Hardware
CM7150Q/EK/CK -HB		#1		 #A 1pc  #B 10pcs  #C 8pcs  #D 10pcs  #E 4pcs  #F 32pcs  #G 14pcs  #H 18pcs  #I 2pcs  #J 4pcs  #K 4pcs  #L 30pcs  #M 6pcs
	Headboard Panel	#4		
	Headboard Support Leg (2pcs)	#7		
CM7150Q/EK/CK -FBR	Footboard	#2		
	Rail (L&R) (2pcs)	#3		
	Slats (11pcs)	#8		
	Slats Whit Hole(3pcs)	#9		
	Center Rail(2pcs)	#10		
	Footboard Leg(2pcs)	#11		
	Slat Support Leg(6pcs)	#12		
	Center Rail Support(2pcs)	#13		
CM7150Q/EK/CK -W	Ear Panel (L&R)( 2pcs)			
	Support Bar(2pcs)			

# Exploded View

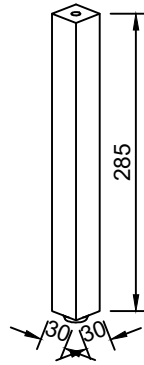
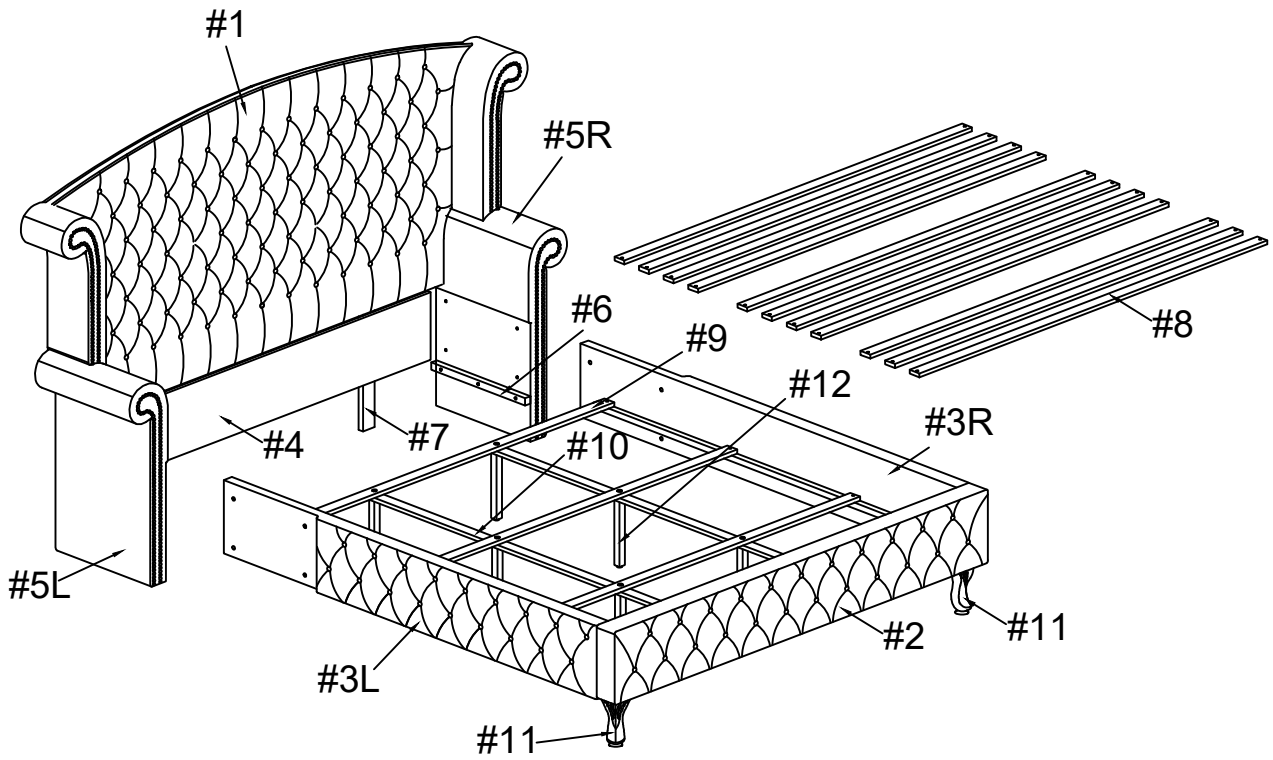

# ASSEMBLY INSTRUCTIONS

1

- Part #1 x1pc
- Part #7 x2pcs
- Hardware #B x4pcs
- Hardware #F x4pcs
- Hardware #H x4pcs

Align HB support rails (#7) to the headboard (#1), then secure by using bolts (#B) with washers (#F,H).

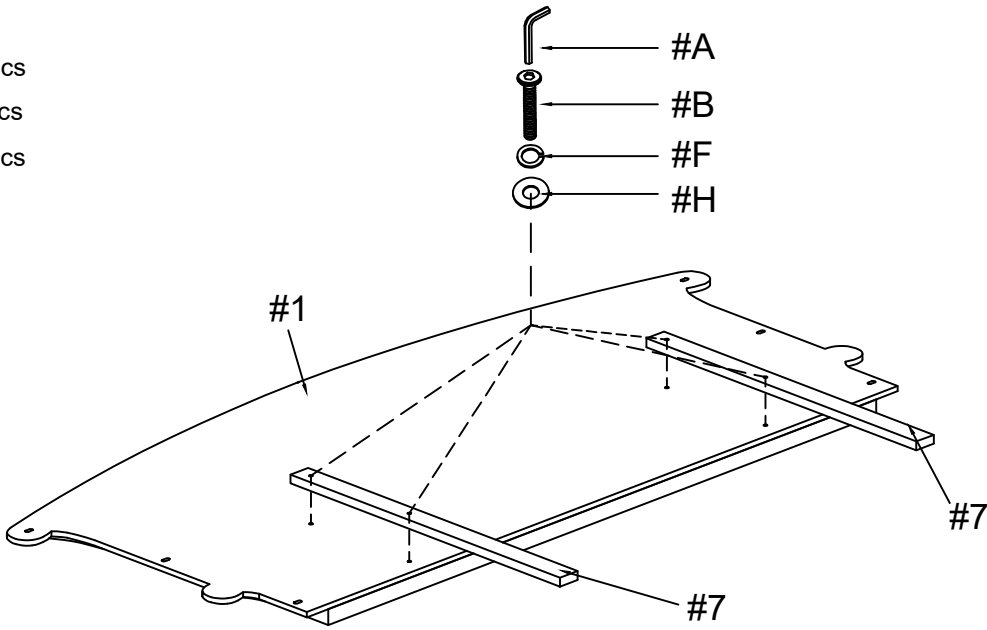

2

- Part #3 x2pcs
- Hardware #B x6pcs
- Hardware #F x6pcs
- Hardware #H x6pcs

Align headboard (#1) to the ear panels (#5R/L), then secure by using bolts (#B) with washers (#F,H).

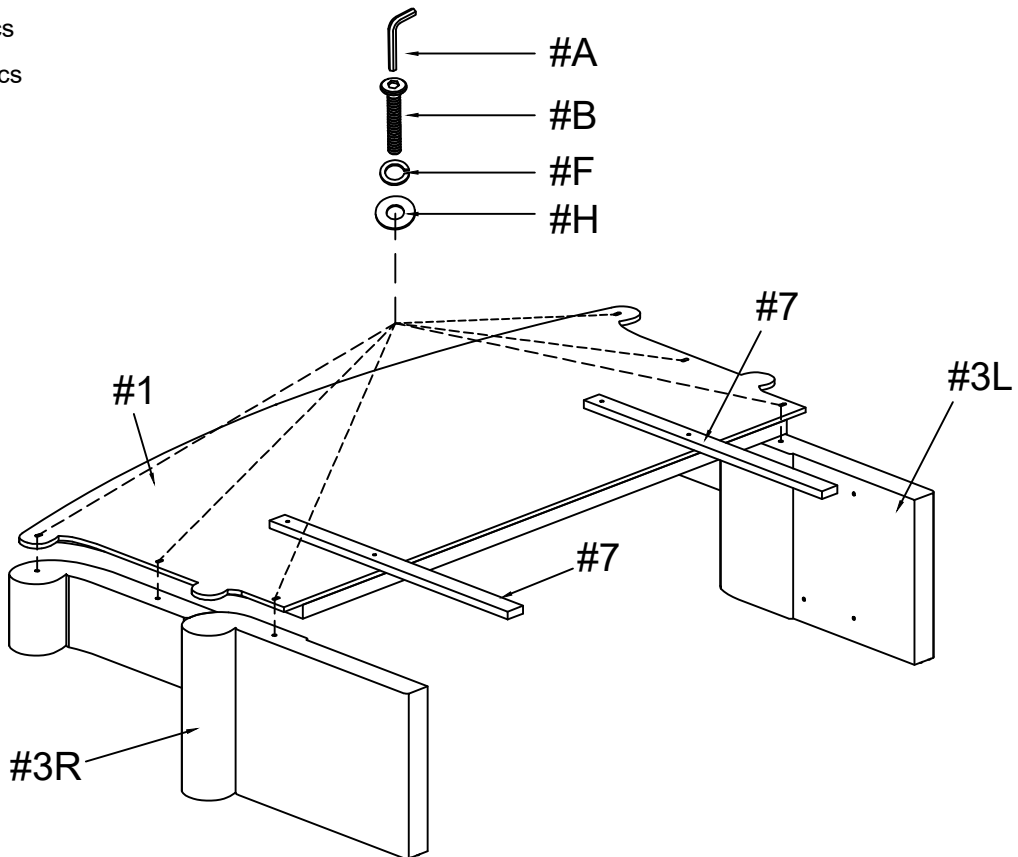

# ASSEMBLY INSTRUCTIONS

## 3

- Part #2 x1pc
- Part #11 x2pcs
- Part #13 x2pcs
- Hardware #D x4pcs
- Hardware #F x4pcs
- Hardware #G x4pcs
- Hardware #I x2pcs
- Hardware #K x2pcs

Align legs (#11) with washer (#I) to the footboard (#2), then secure by using screws (#K)

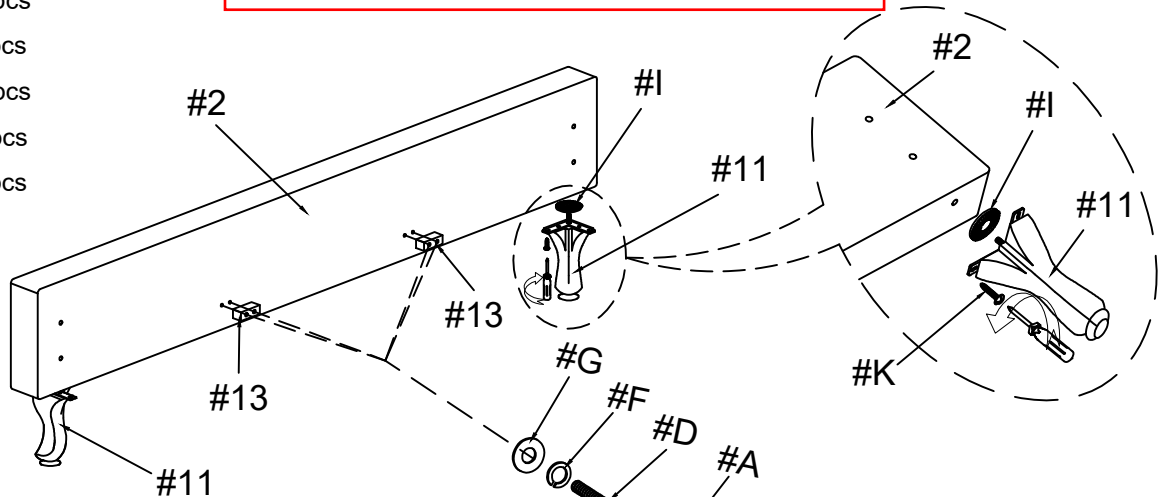

Align center rail supports (#13) to the footboard (#2), then secure by using bolts (#D) with washers (#F,G).

## 4

- Hardware #E x4pcs
- Hardware #F x4pcs
- Hardware #G x4pcs
- Hardware #K x 2pcs

Align side rails (#3R/L) to the footboard (#2), then secure by using bolts (#E) with washers (#F,G).

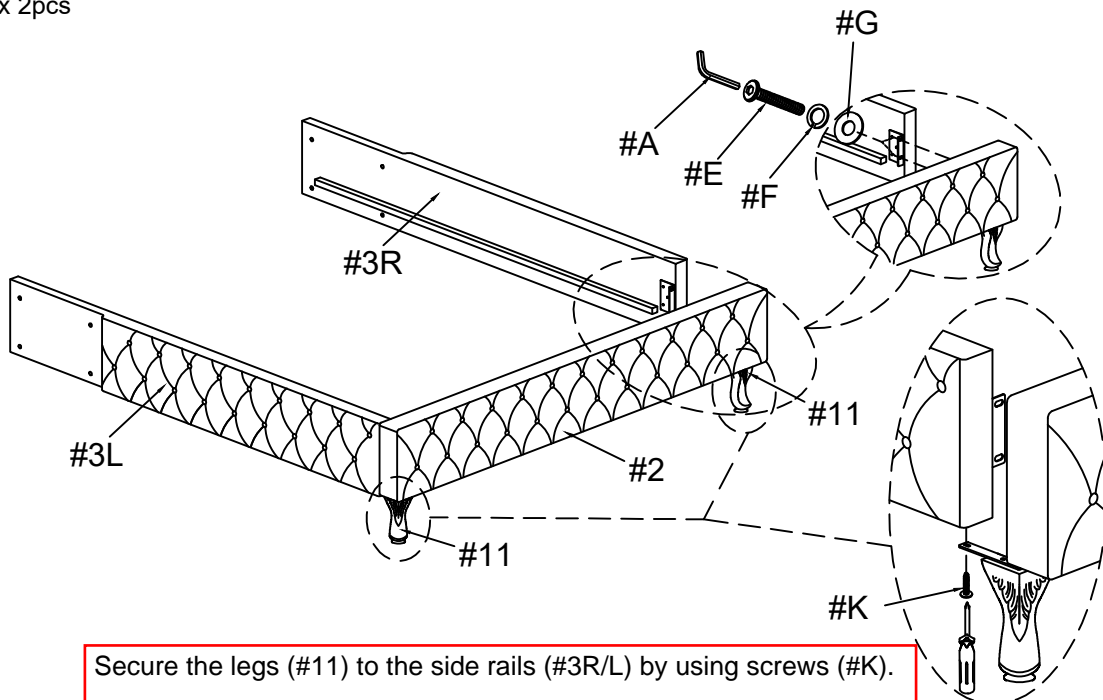

Secure the legs (#11) to the side rails (#3R/L) by using screws (#K).

# ASSEMBLY INSTRUCTIONS

5

- Part #2 x1pc
- Part #3 x2pcs
- Part #6 x2pcs
- Hardware #C x8pcs
- Hardware #F x8pcs
- Hardware #H x8pcs
- Hardware #M x6pcs

Align support bars (#6) to the bottom of the side rails (#3R/L), then secure by using screws (#M). Secure side rails (#3R/L) to HB ears (#5R/L) by using bolts (#C) with washers (#F,H).

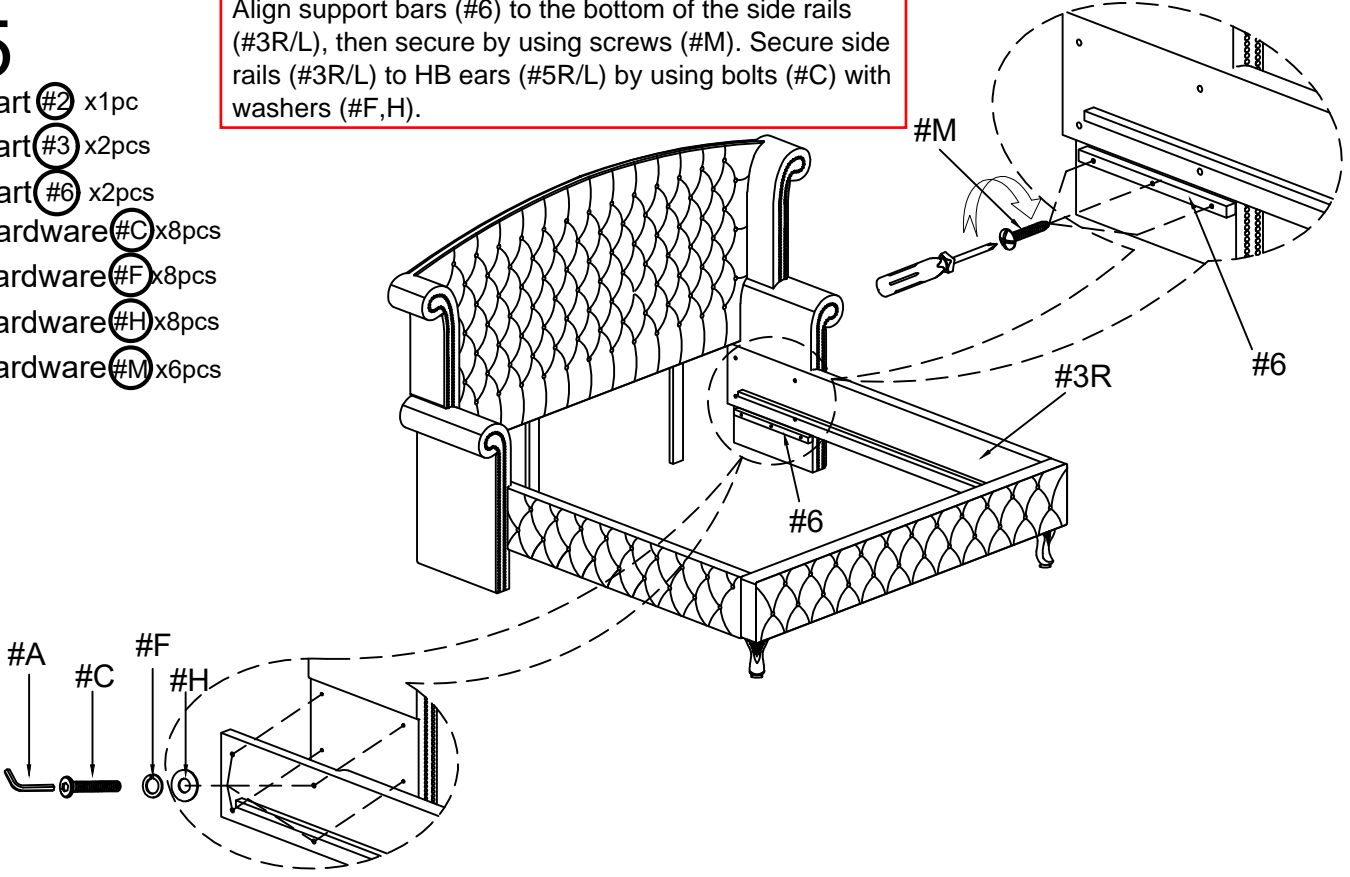

6

- Part #4 x1pc
- Hardware #J x4pcs

Align HB panel (#4) to the headboard, then secure by using screws (#J).

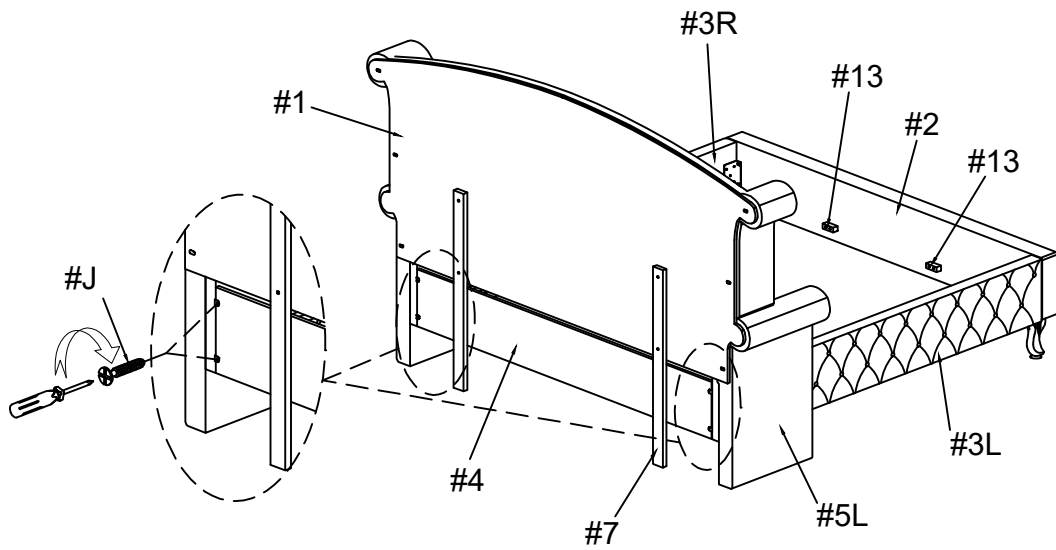

# ASSEMBLY INSTRUCTIONS

## 7

- Part #9 x3pcs
- Part #10 x2pcs
- Part #12 x6pcs
- Hardware #D x6pcs
- Hardware #F x6pcs
- Hardware #G x6pcs

Align center rails (#10) to the slats (#9) and slat support legs (#12), then secure by using bolts (#D) with washers (#F,G).

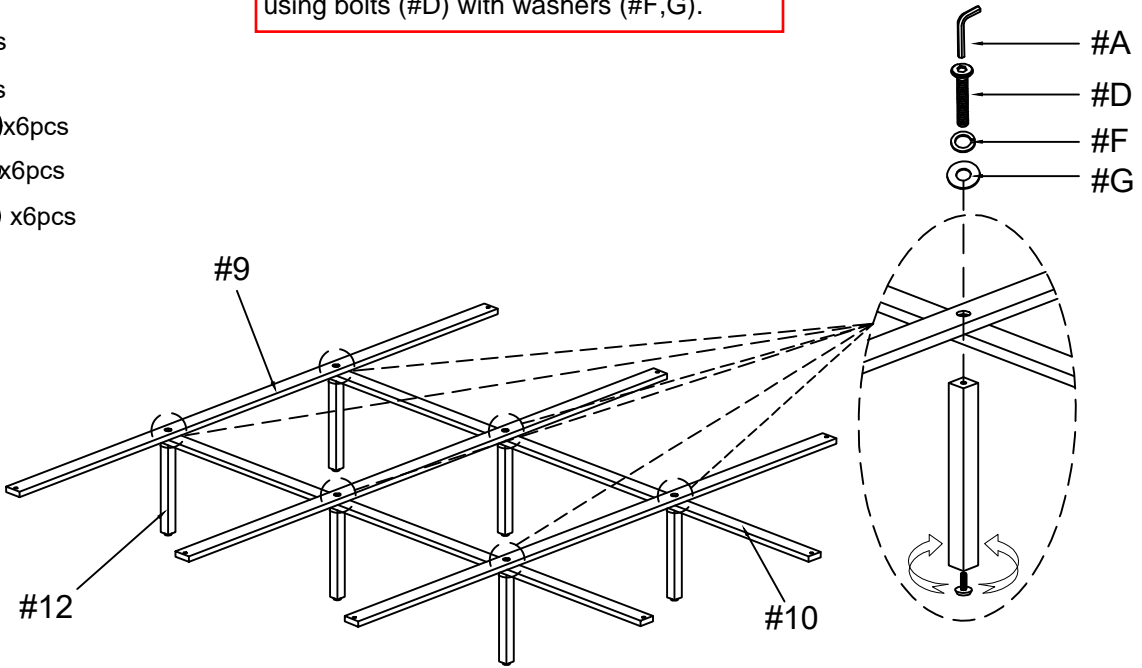

## 8

- Hardware #L x8pcs

Secure slats (#9) to side rails (#3R/L) by using screws (#L).

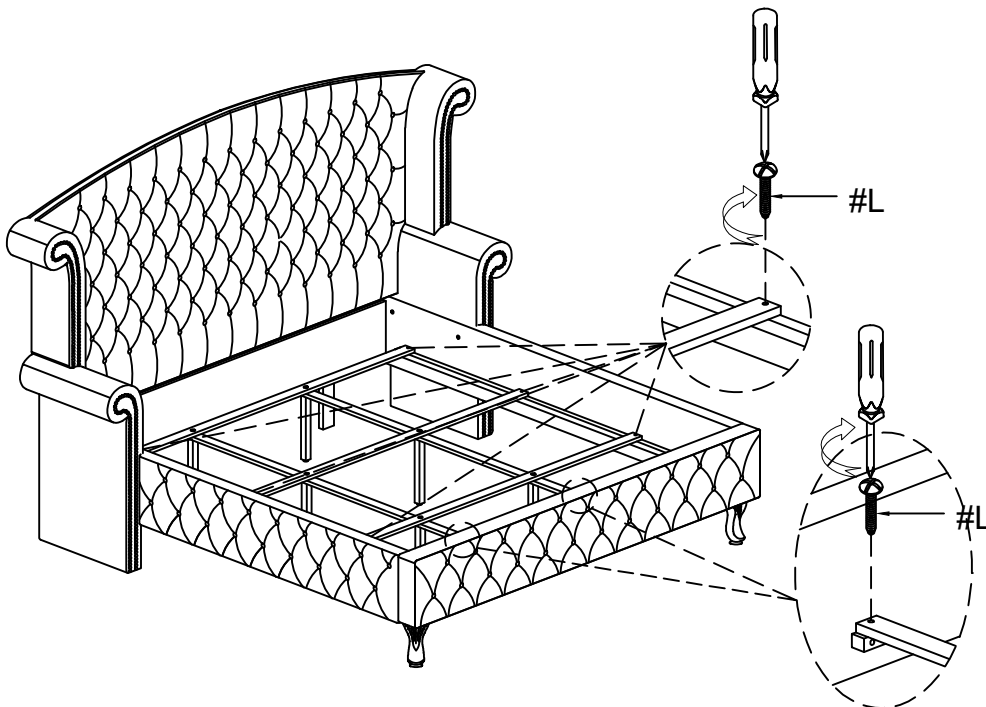

# ASSEMBLY INSTRUCTIONS

9

Hardware (#L)x22pcs

Align slats (#8) to the side rails (#3R/L), then secure by using screws (#L).

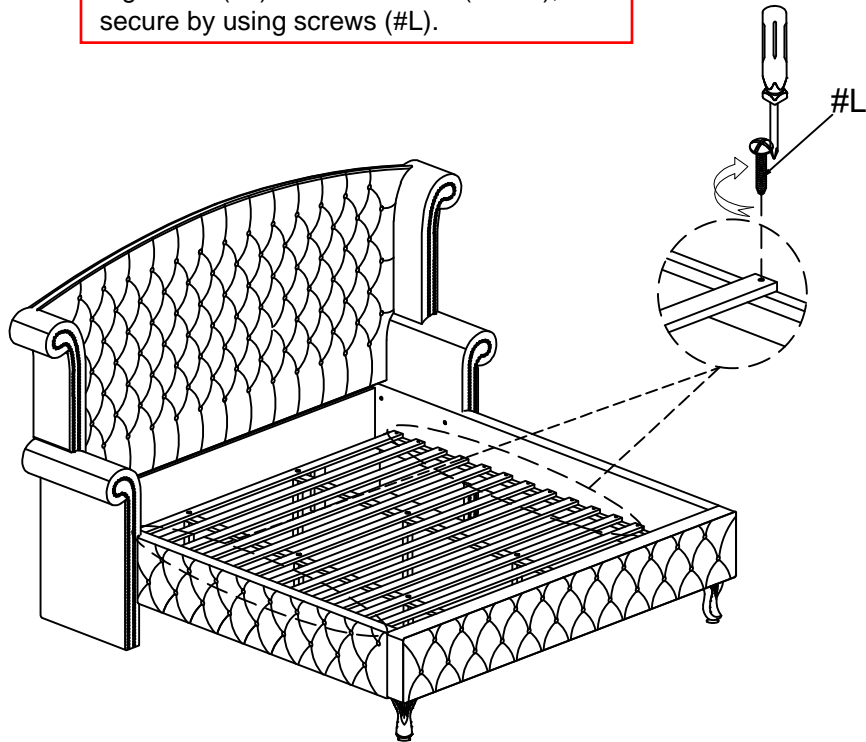

10

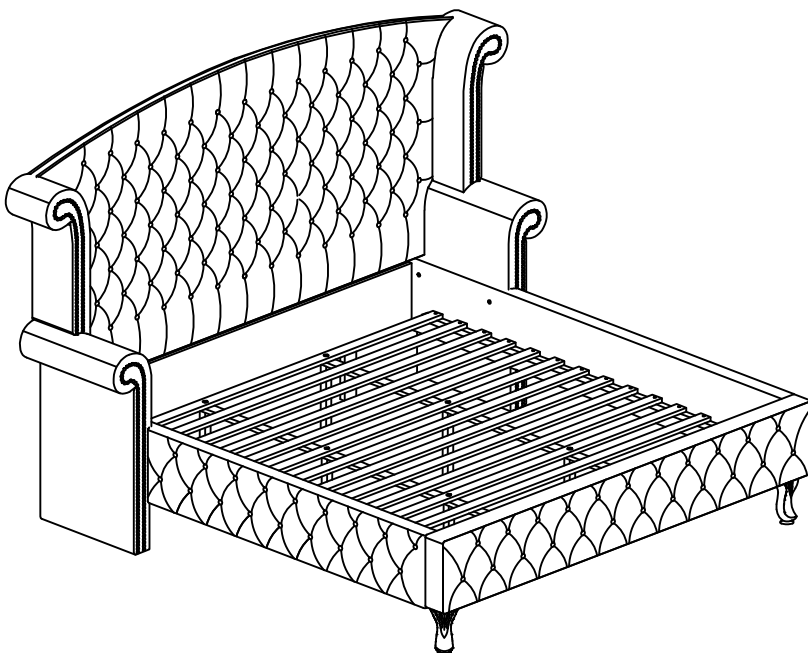

## ASSEMBLY COMPLETED



Please ensure the furniture rests on an even and flat surface. If the product wobbles or feels loose, double-check all bolts and/or screws are properly tightened and secured.



### Keep this handy!

Please retain this instruction manual and any order-related information for future reference.



### Lift, don't drag!

To avoid damage to product please always LIFT the product when transporting or adjusting the placement.