

# *ASSEMBLY INSTRUCTIONS*



# ASSEMBLY INSTRUCTIONS

## ASSEMBLY TIPS:

1. Remove hardware from box and sort by size.
2. Please check to see that all hardware and parts are present prior to start of assembly.
3. Please follow attached instructions in the same sequence as numbered to assure fast & easy assembly.



### WARNING!







1. Don't attempt to repair or modify parts that are broken or defective. Please contact the store immediately.
2. This product is for home use only and not intended for commercial establishments.

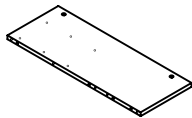
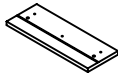
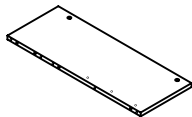

ASSEMBLY TIME

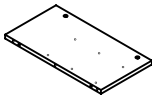

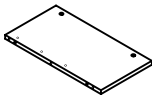

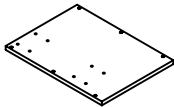
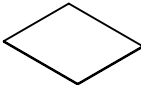
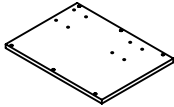
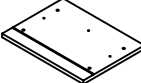
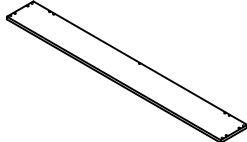
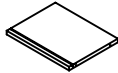
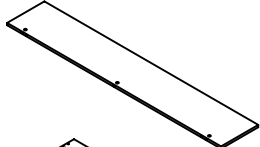
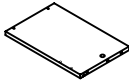
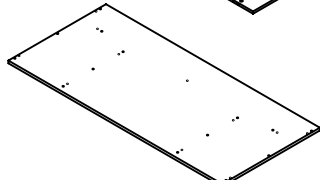
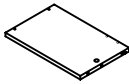
60 MINUTES





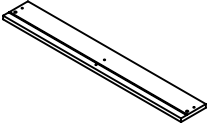
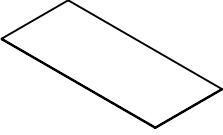
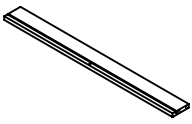

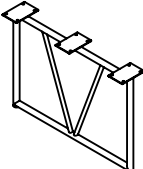



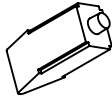

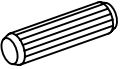
## PARTS IDENTIFICATION

AN	LEFT SIDE PANEL		1 PC	JN	LEFT DRAWER FRONT PANEL		2 PCS
BN	RIGHT SIDE PANEL		1 PC	KN	SMALL DRAWER BACK PANEL		2 PCS
CN	LEFT DIVIDER PANEL		1 PC	LN	SMALL LEFT DRAWER SIDE PANEL		2 PCS
DN	RIGHT DIVIDER PANEL		1 PC	MN	SMALL RIGHT DRAWER SIDE PANEL		2 PCS
EN	LEFT BOTTOM PANEL		1 PC	NN	DRAWER BOTTOM PANEL		3 PCS
FN	RIGHT BOTTOM PANEL		1 PC	ON	RIGHT DRAWER FRONT PANEL		1 PC
GN	BACK BOTTOM PANEL		1 PC	PN	LARGE DRAWER BACK PANEL		1 PC
HN	BACK PANEL		1 PC	QN	LARGE LEFT DRAWER SIDE PANEL		1 PC
IN	TOP PANEL		1 PC	RN	LARGE RIGHT DRAWER SIDE PANEL		1 PC

### NOTE:

Phillips head screw driver is required in the assembly process; however, manufacturer does not provide this item.

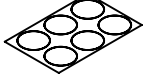
SN	MIDDLE DRAWER FRONT PANEL		1 PC	A1N	MIDDLE DRAWER BOTTOM PANEL		1 PC
TN	MIDDLE DRAWER BACK PANEL		1 PC	B1N	DRAWER SUPPORT		1 PC
UN	MIDDLE LEFT DRAWER SIDE PANEL		1 PC	C1N	METAL FRAME		2 PCS
VN	MIDDLE RIGHT DRAWER SIDE PANEL		1 PC				

<b>Z</b>							
<b>HARDWARE IDENTIFICATION</b>							
NO	DESCRIPTION	FIGURE	Q'TY	NO	DESCRIPTION	FIGURE	Q'TY
1	GLUE 40g		1 PC	8	SCREW FOR RAIL Ø 3.5x12mm SR		40 PCS
2	WOODEN DOWEL Ø 8x30mm		38 PCS	9	KNOB		4 PCS
3	CAM BOLT Ø 7x35.5mm SR		20 PCS	10	KNOB BOLT Ø 4x28mm BLK		4 PCS
4	CAM LOCK Ø 15x12mm SR		20 PCS	11	BOLT M 6x20mm BLK		24 PCS
5	LONG SCREW Ø 4.5x42mm SR		19 PCS	12	ALLEN WRENCH 4mm SR		1 PC
6	SCREW Ø 4.3x35mm SR		17 PCS	13	STICKER Ø 20mm		4 PCS
7	RAIL L = 350mm SR		4 SET				

Z7 not included in blister packaging.

**NOTE:**

Phillips head screw driver is required in the assembly process; however, manufacturer does not provide this item.

# STEP 1

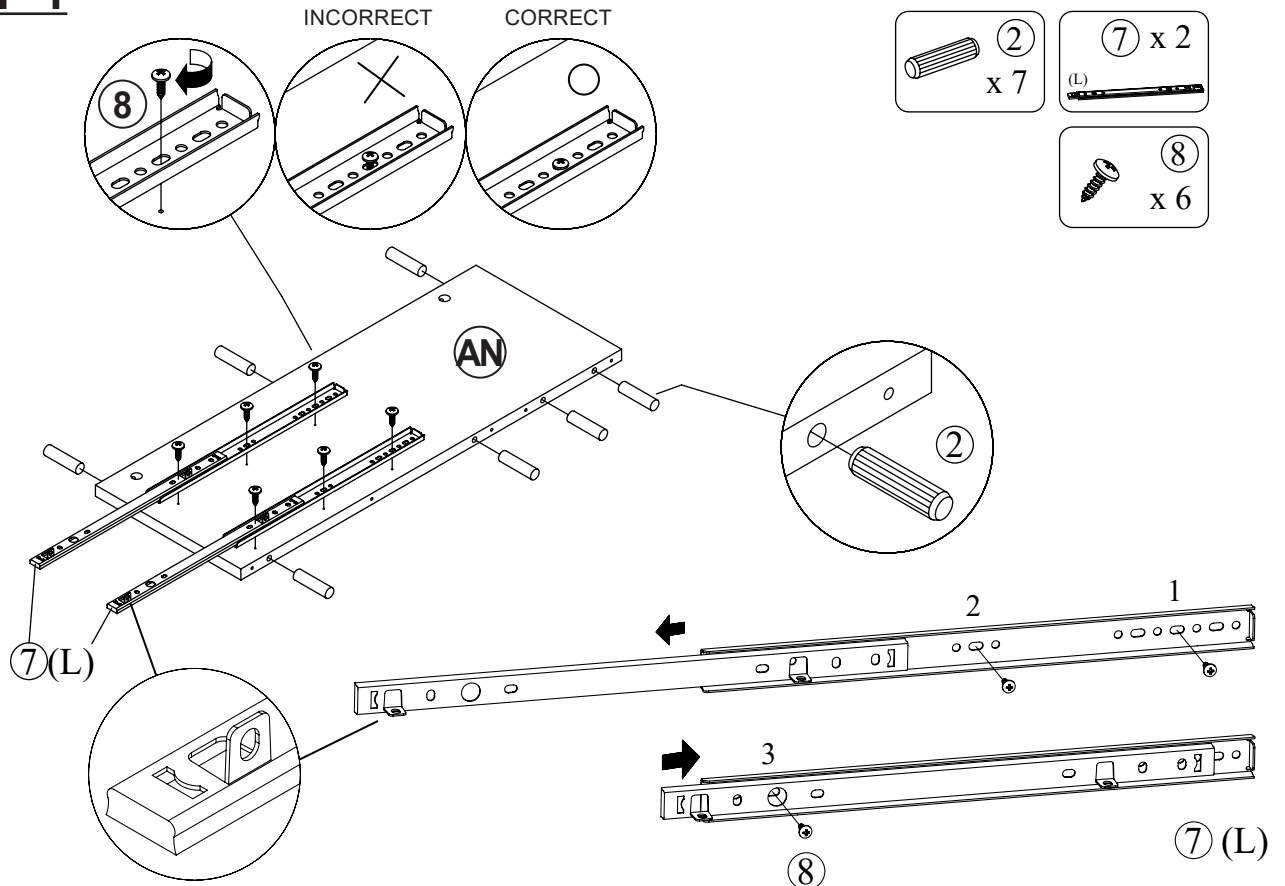

# STEP 2

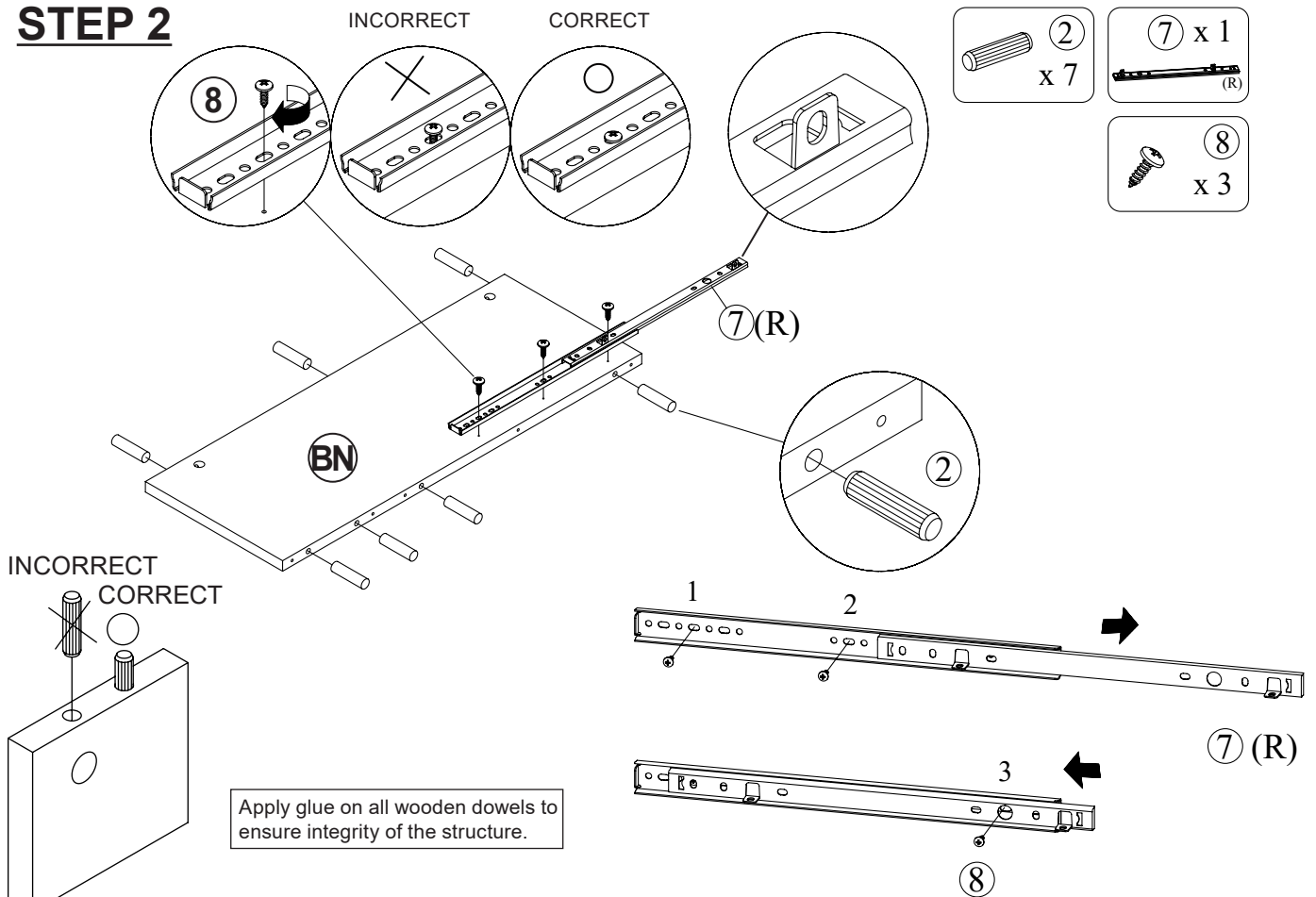

# STEP 3

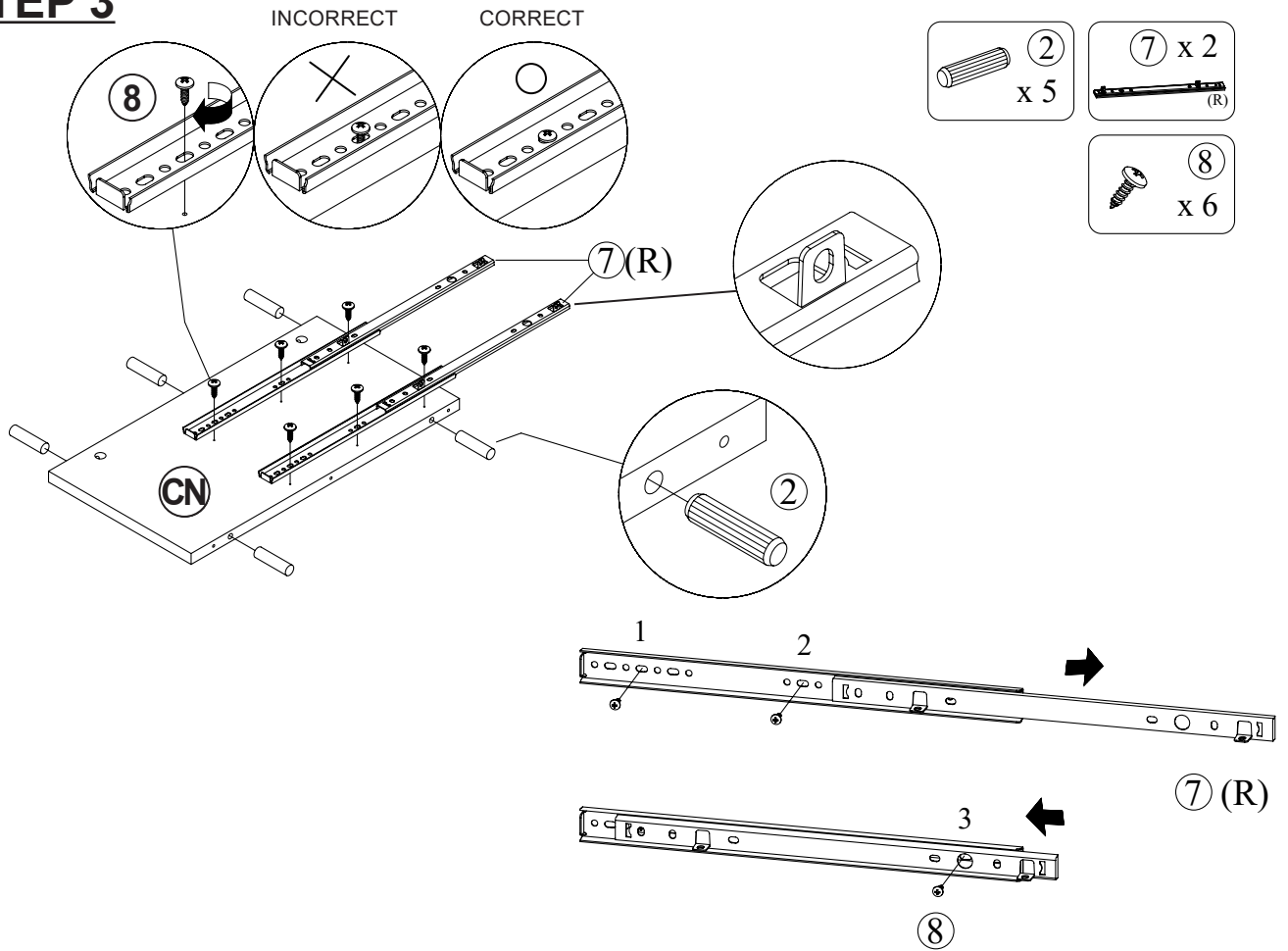

↓ the reverse side

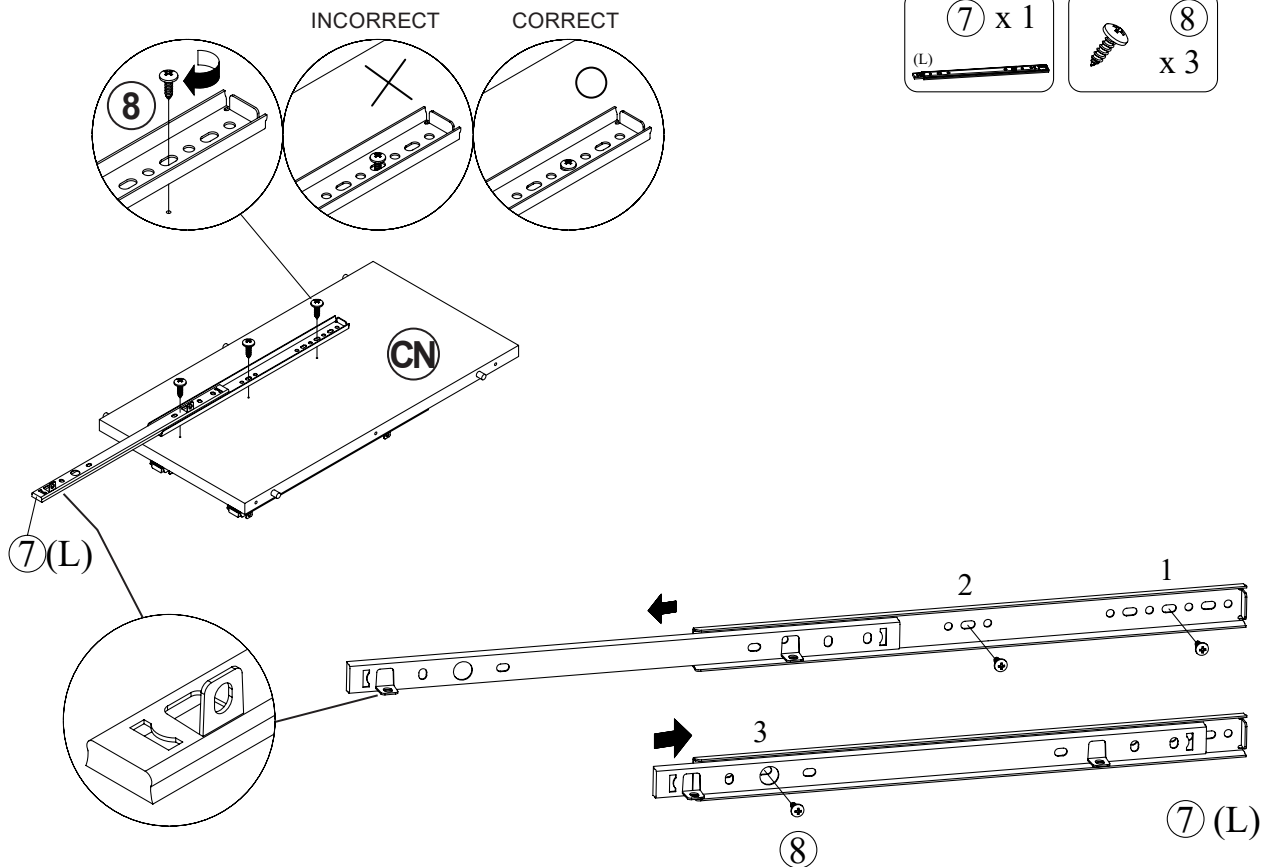

# STEP 4

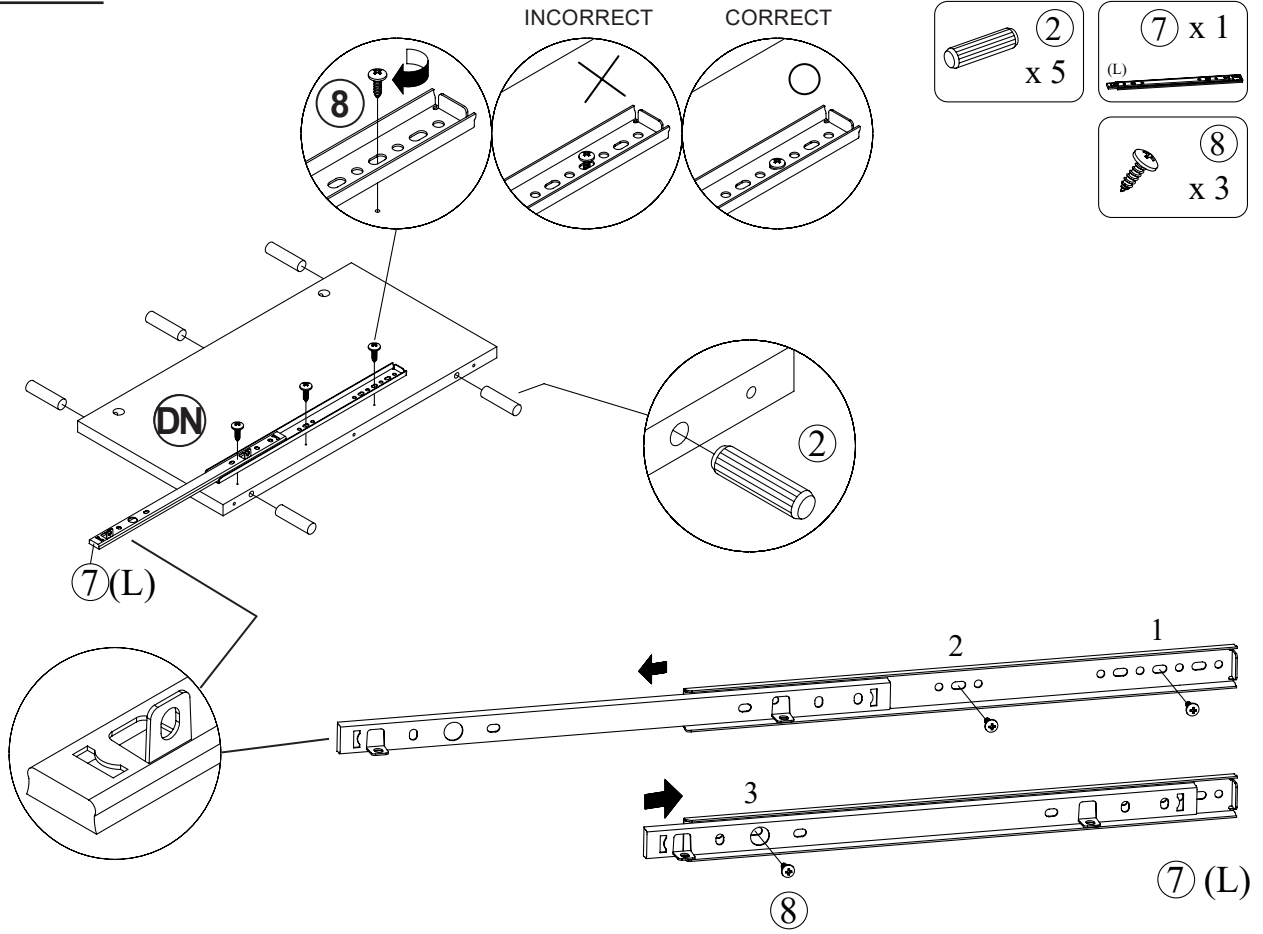

## ↓ the reverse side

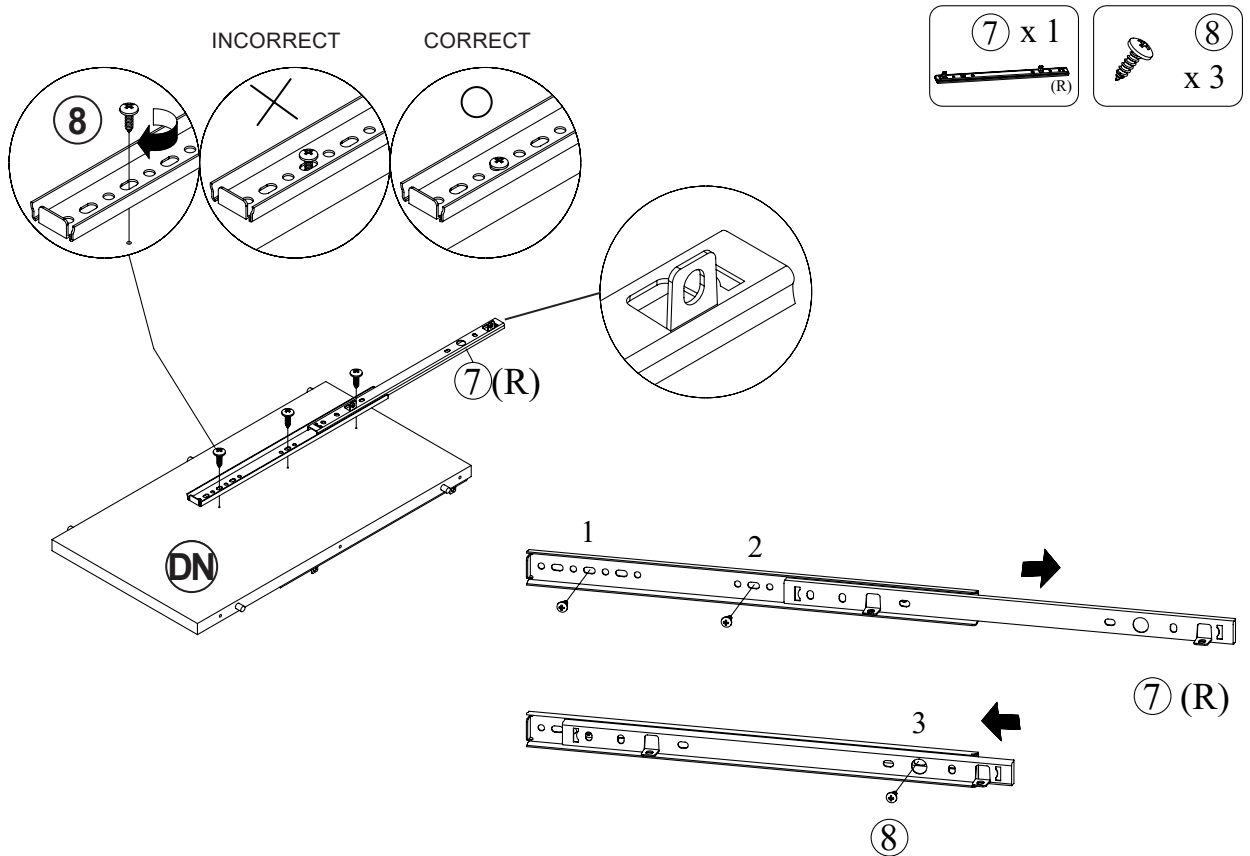

## STEP 5

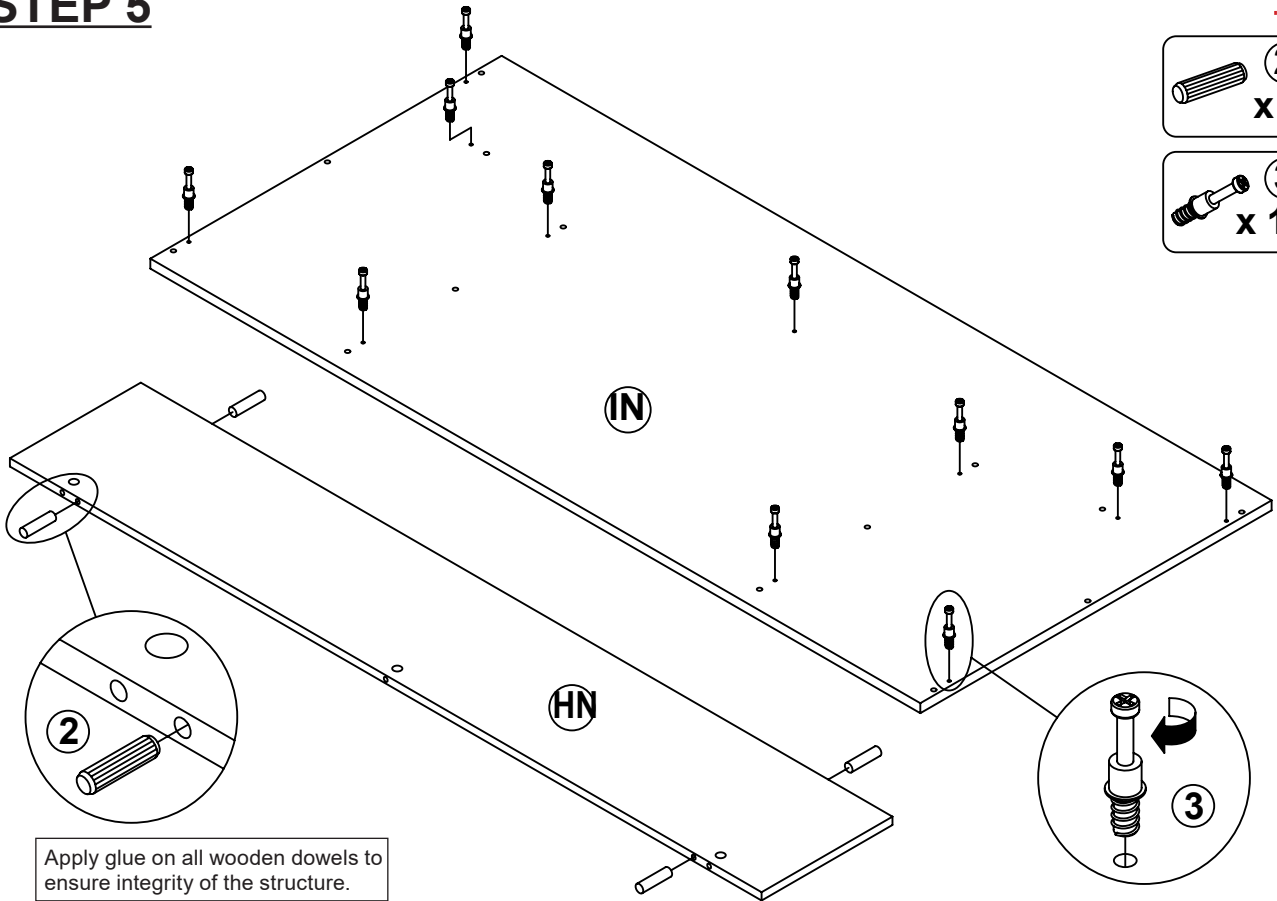
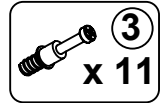
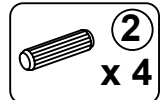

Apply glue on all wooden dowels to ensure integrity of the structure.

## STEP 6

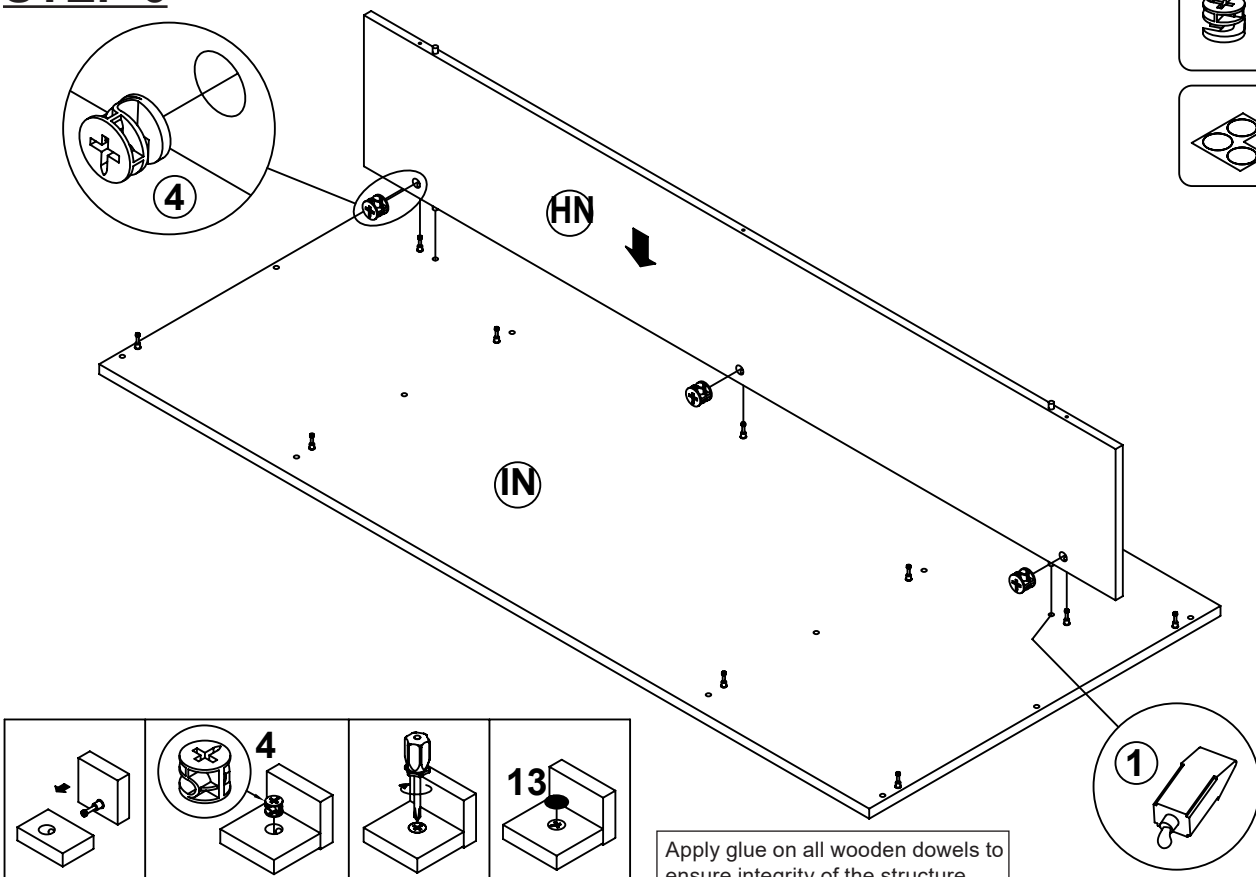
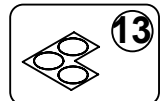
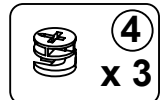

Apply glue on all wooden dowels to ensure integrity of the structure.

## STEP 7

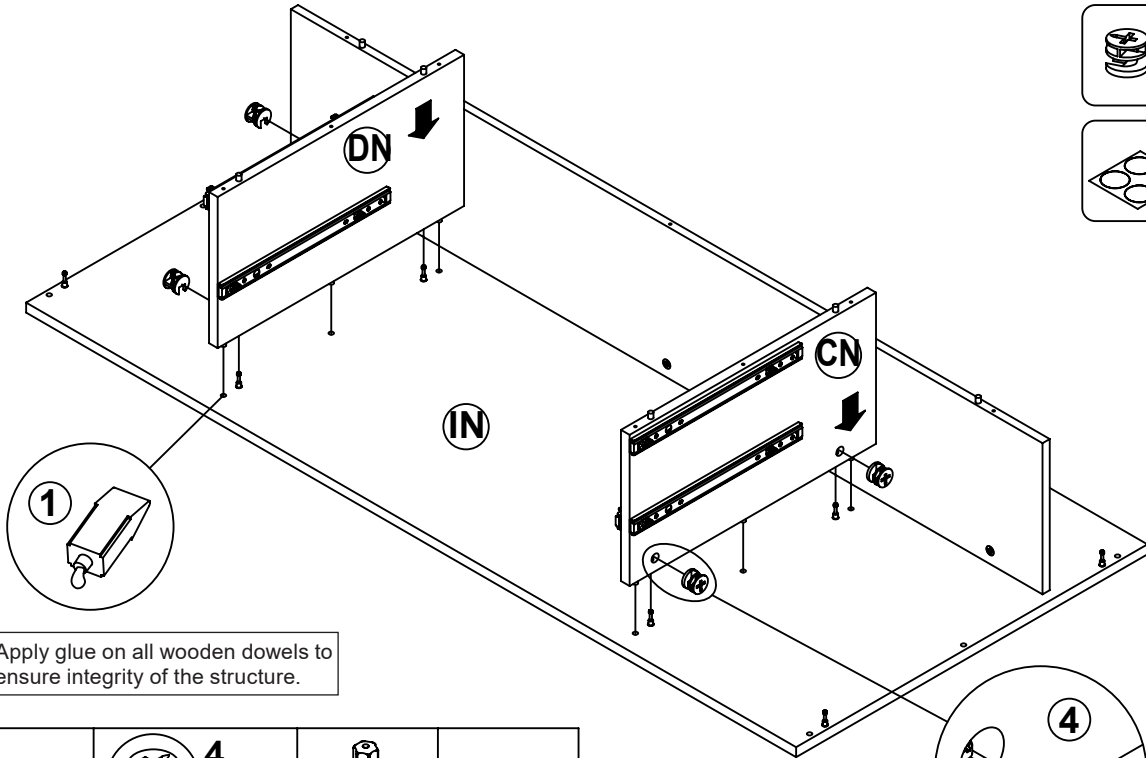

Apply glue on all wooden dowels to ensure integrity of the structure.

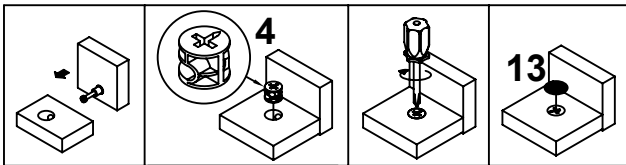

## STEP 8

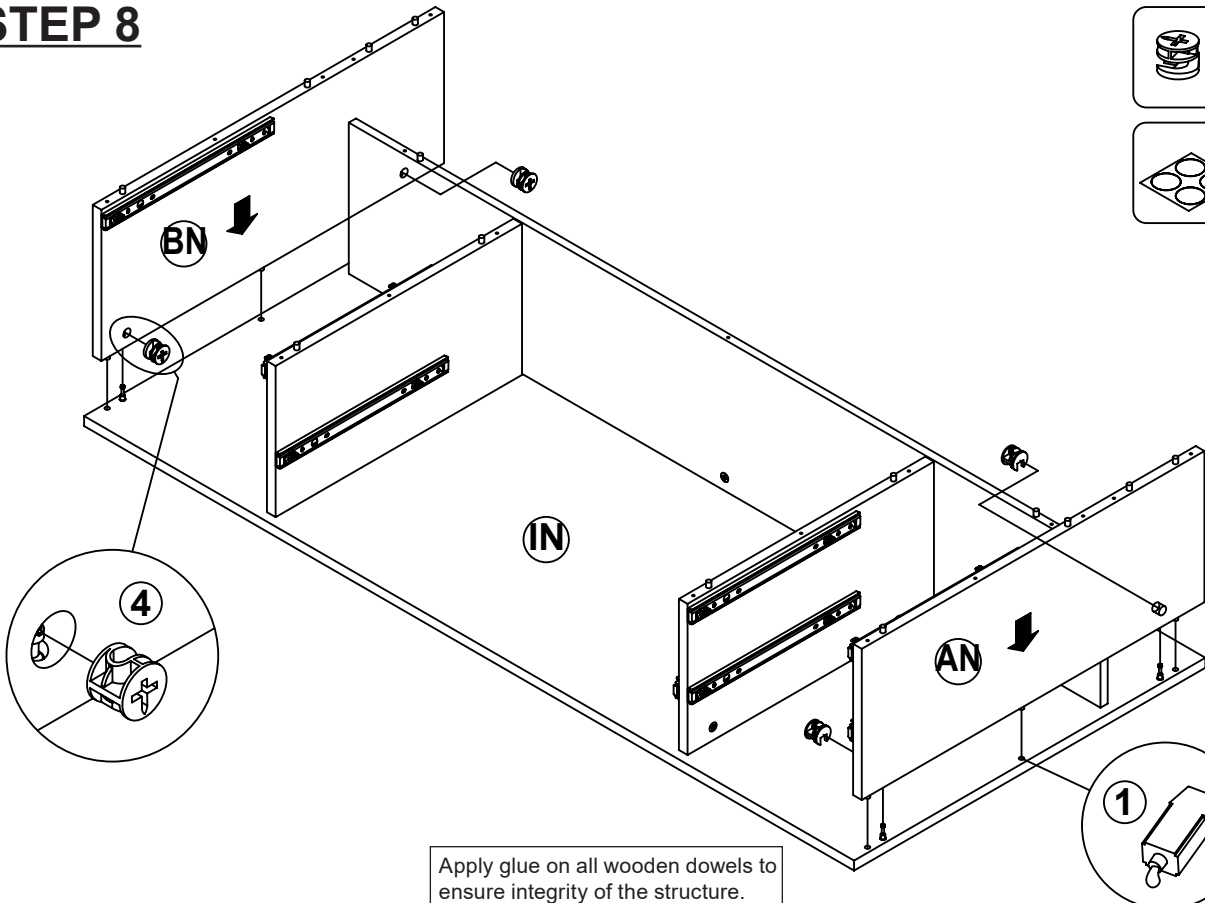

Apply glue on all wooden dowels to ensure integrity of the structure.

## STEP 9

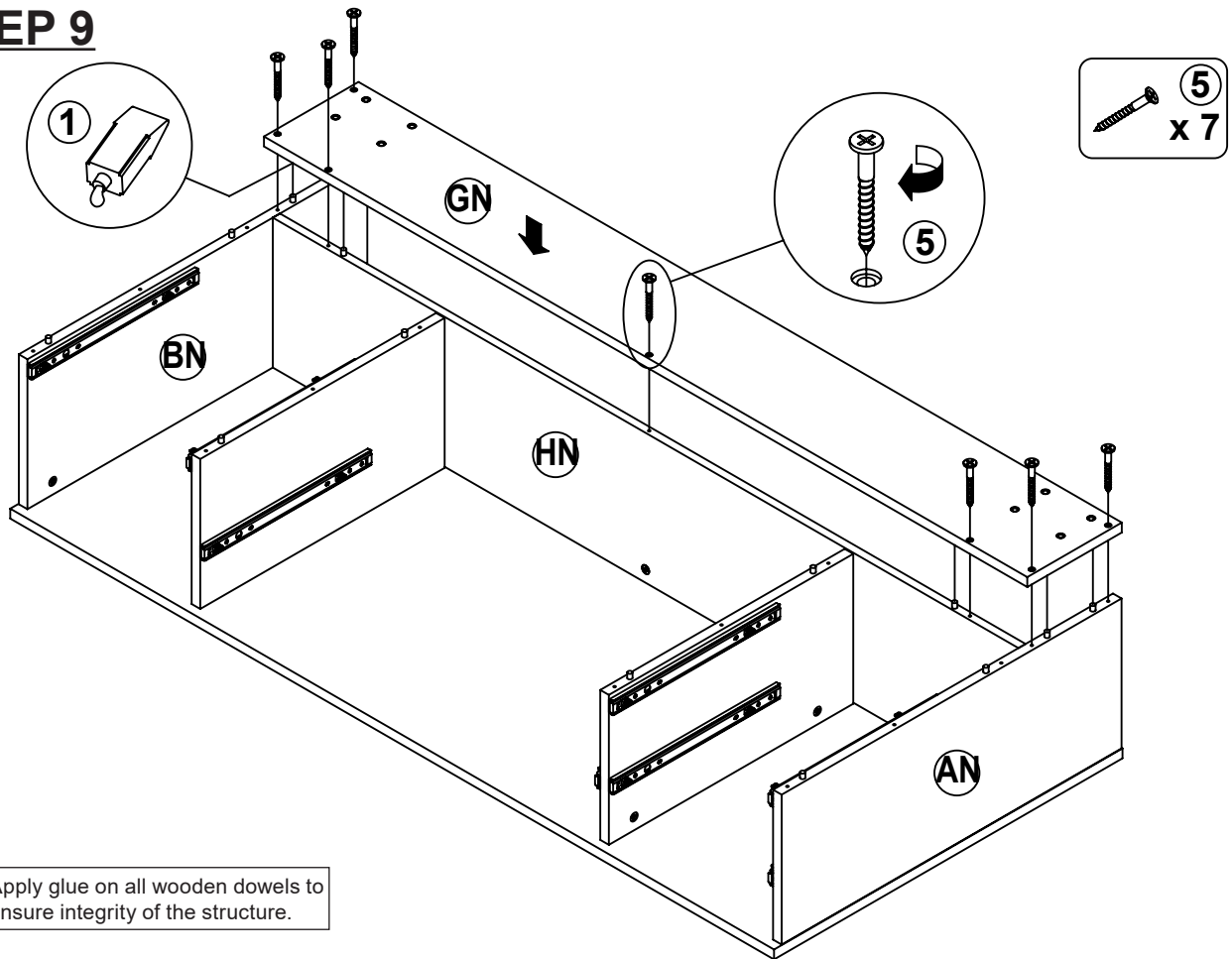

## STEP 10

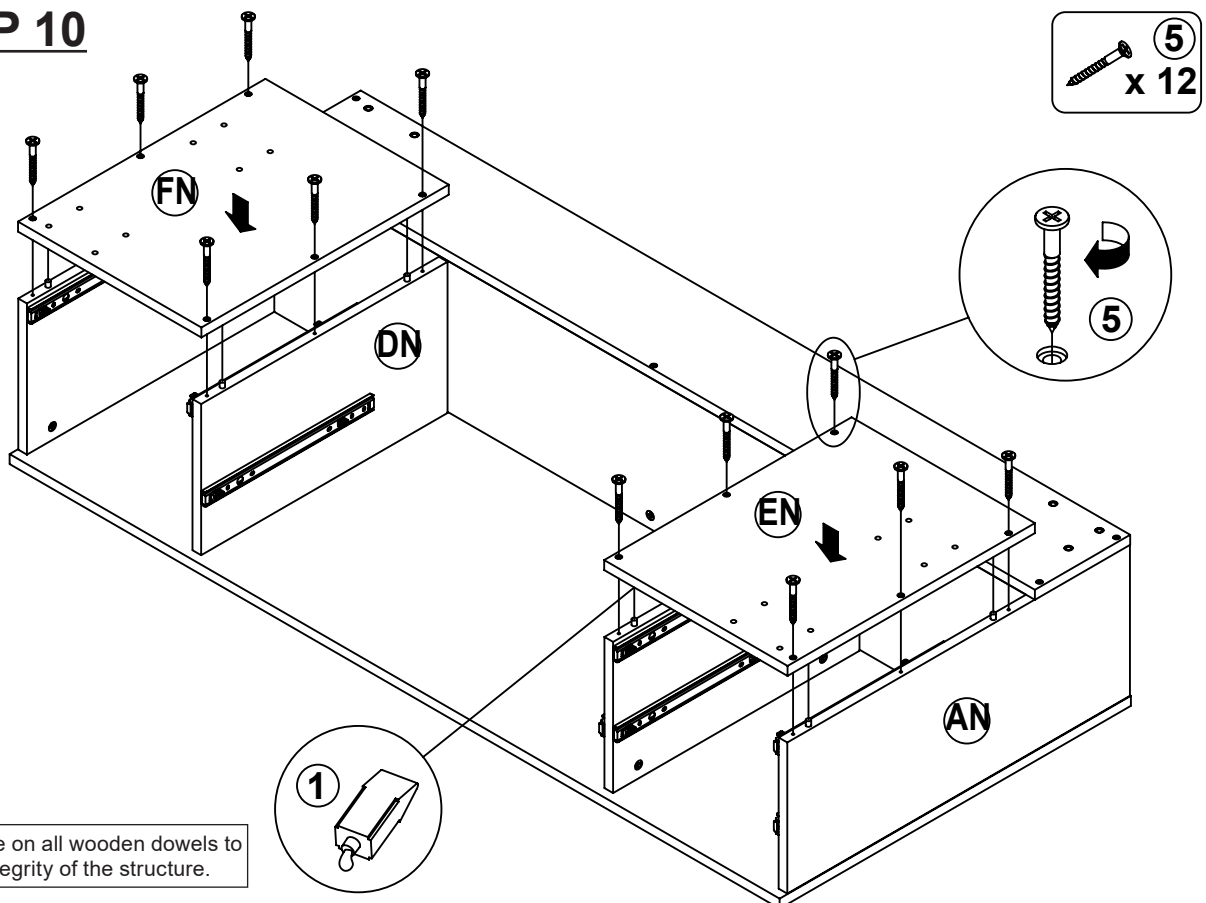



## STEP 13

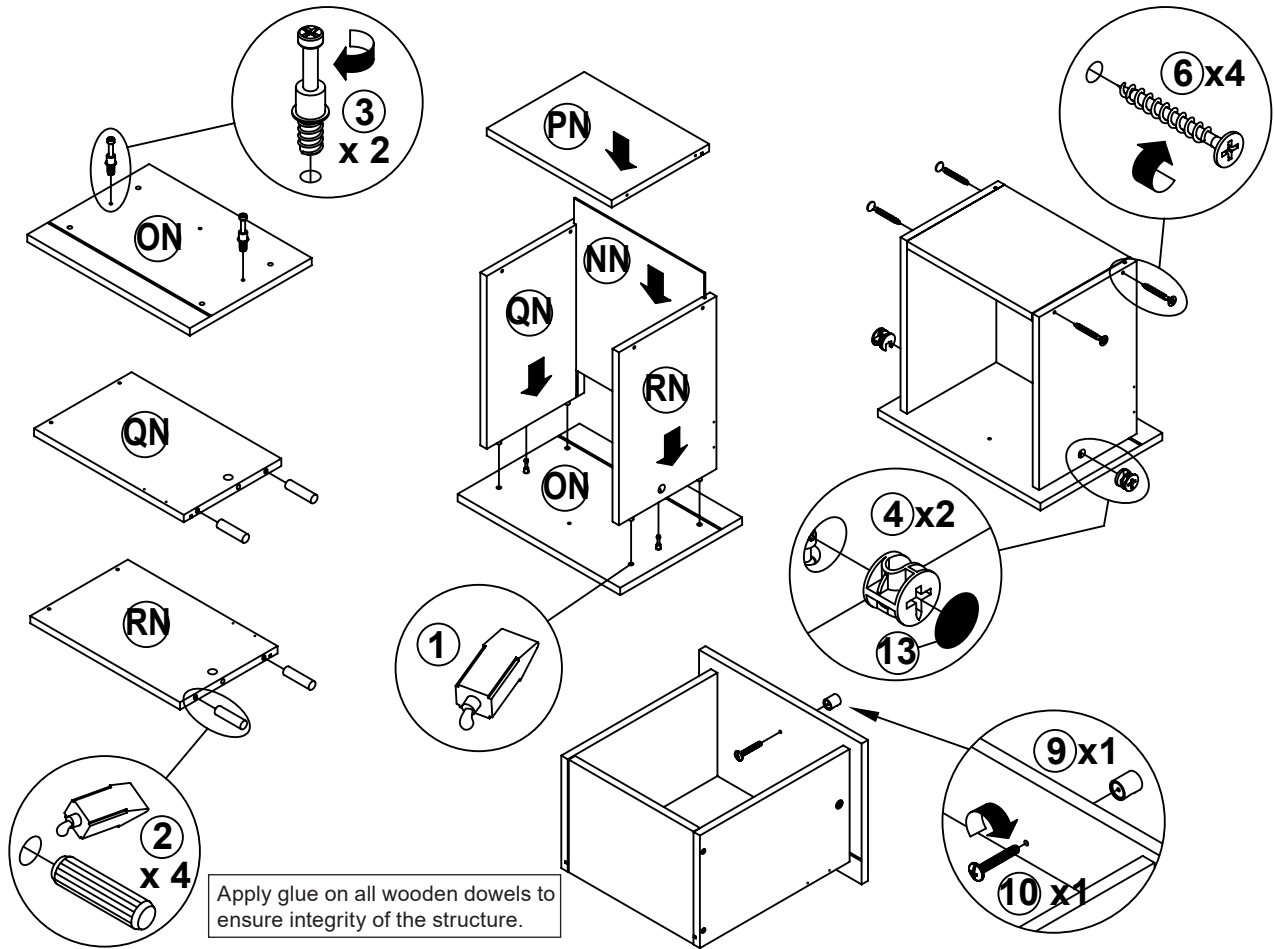

## STEP 14

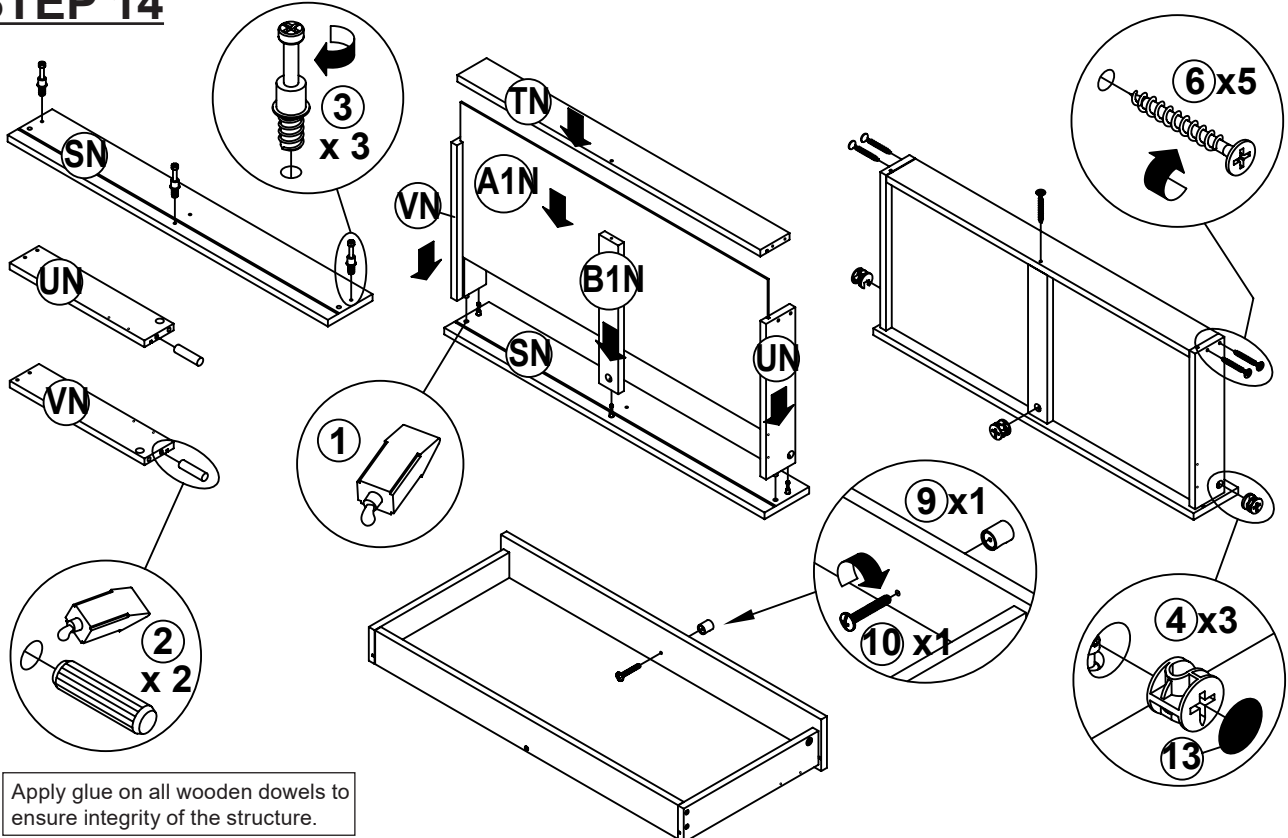

## STEP 15

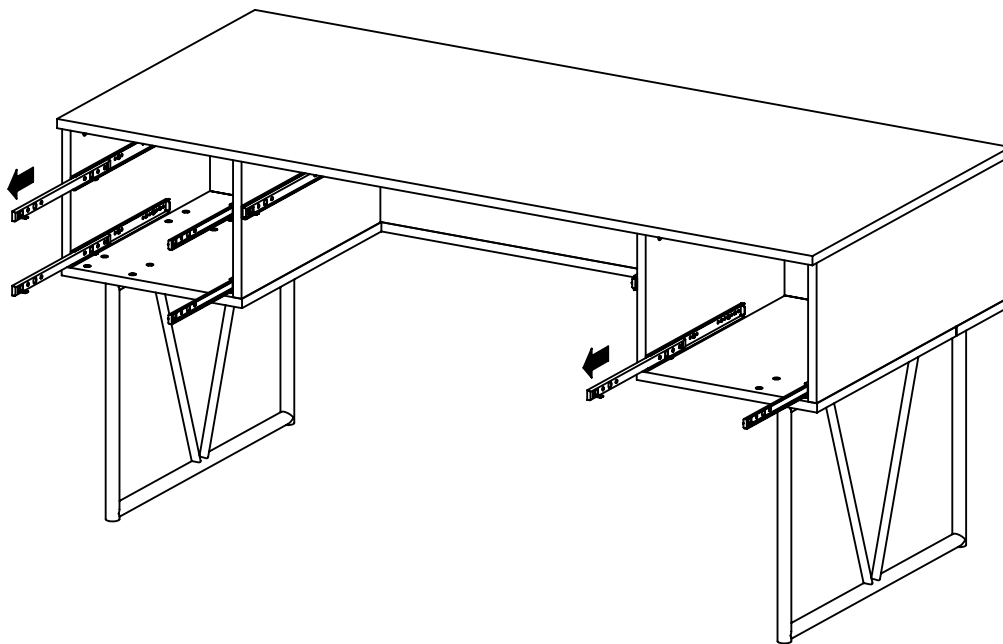

## STEP 16

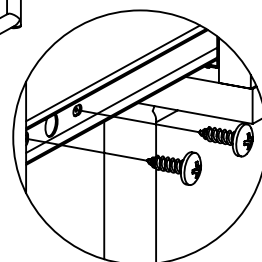
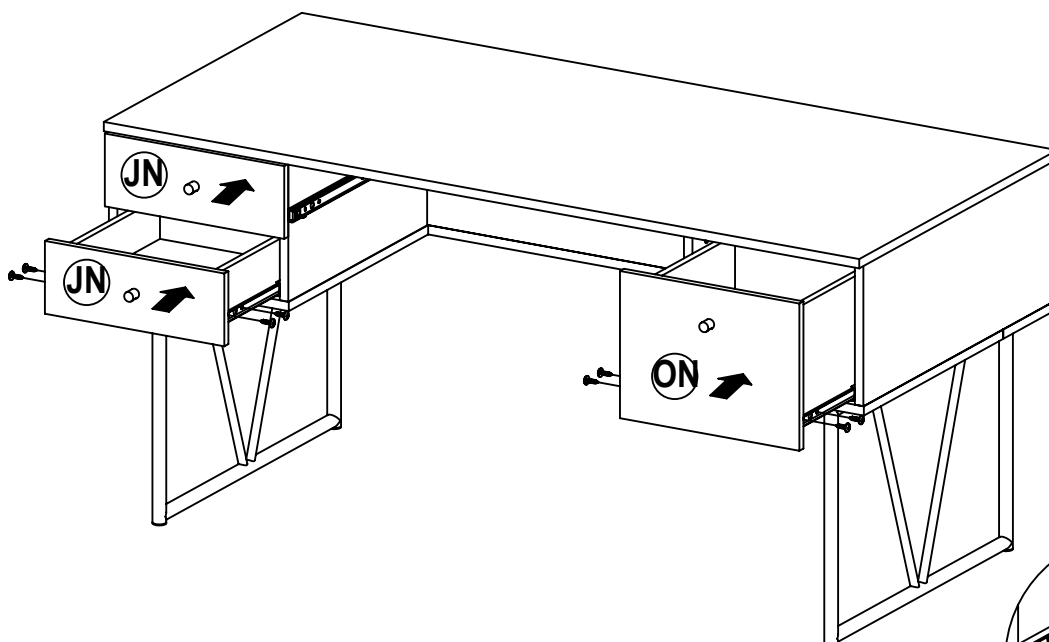
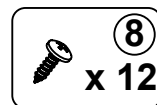

## STEP 17

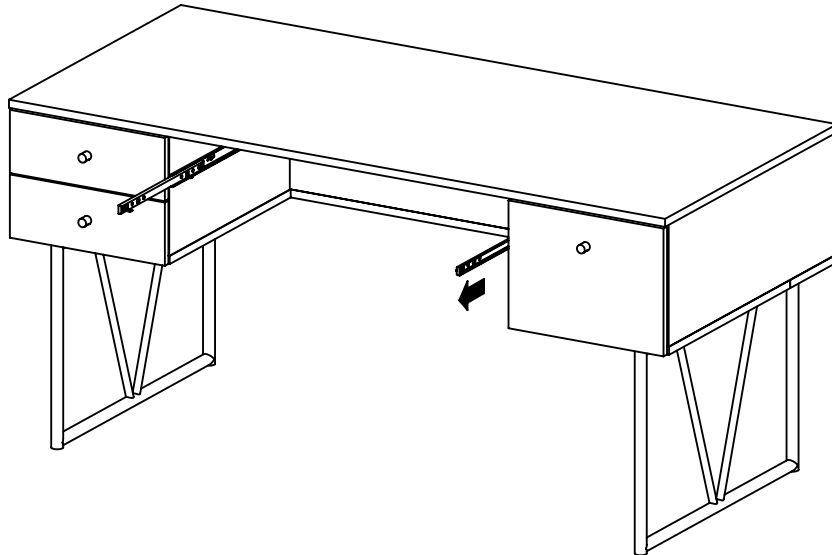

## STEP 18

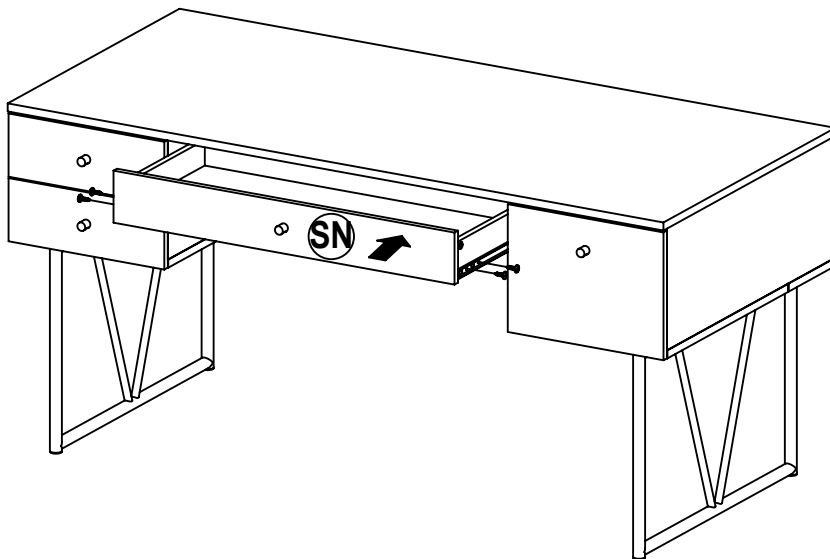
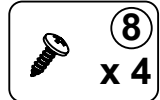

## STEP 19 COMPLETE

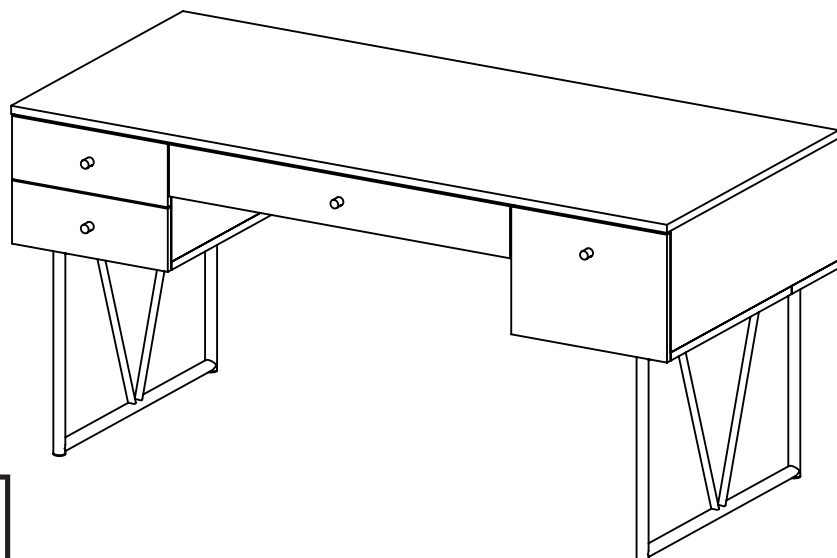

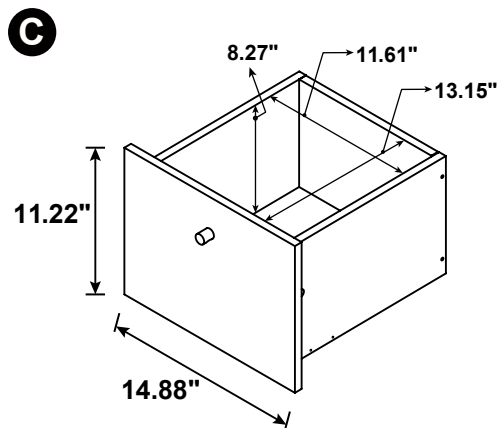
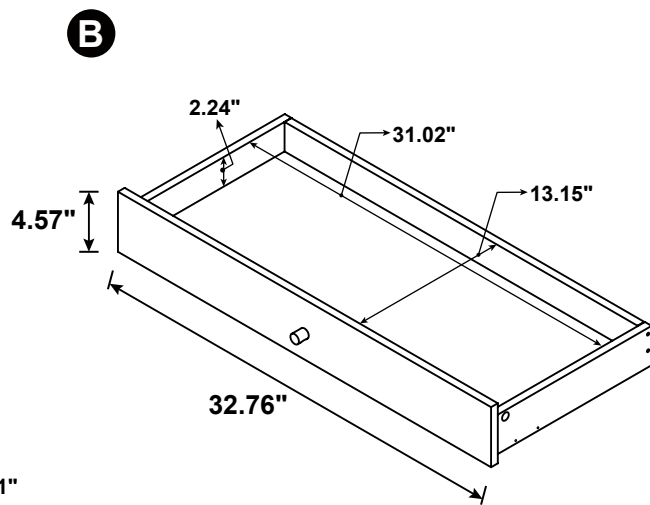
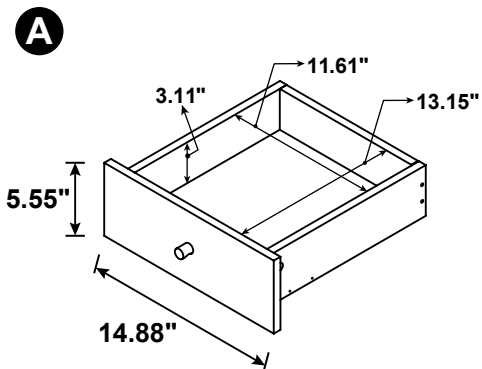
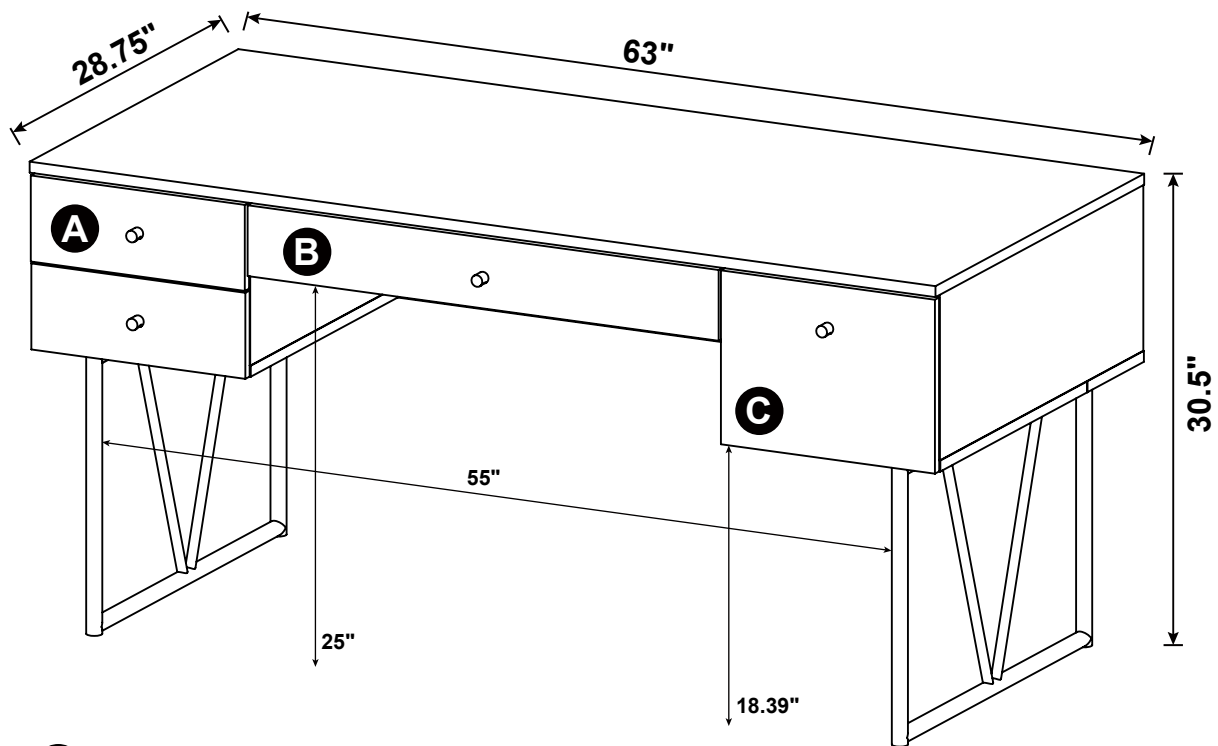

Note : Dimension tolerance  $\pm 5\%$