

ASSEMBLY INSTRUCTION

The cat cage

N719P418377

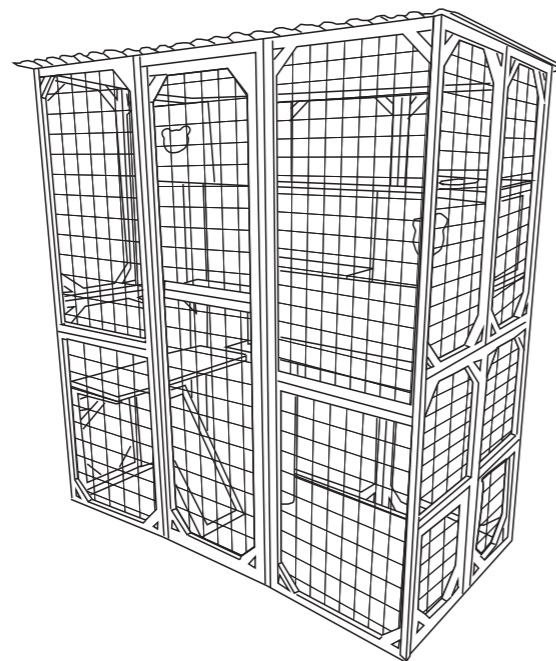

Notice :

1. 50% Tighten before fixing all screws, Allen wrench is recommended instead of an electric drill.
2. Place the item on a flat ground to adjust and make sure it remains stable.
3. Tighten up all screws with tools gradually.
4. If the screws are not aligned with holes during assembly. please loosen all the other screws to 50% and continue the assembly process.
5. If the item is not stable, please loosen all the screws, adjust it on a flat ground and tighten up all screws again.
6. Note: If one or some screws are fully tightened during assembly, chances are the others will not be aligned with holes. In addition, all the holes are designed to be relatively larger to provide more space for the adjustment of the screws.

Parts List

A1 4X50mm 44pcs	A2 4X40mm 28pcs	A3 4X25mm 58pcs	A4 6X40mm 20pcs	A5 10X30mm 1pc	A6 10X50mm 1pc	A7 2 pcs	A8 2 pcs		
B 2pcs	C 1pc	D 1pc	E 1pc	F 1pc	G 1pc	H 2pcs	H1 6pcs	H2 2pcs	I 1pc
J 1pc	K 1pc	L 1pc	M 1pc	N 1pc	O 1pc	P 1pc	Q 1pc	R 1pc	S 1pc
T 1pc	U 1pc	V 1pc	W 1pc	X 1pc	Y 1pc	Z 2pcs	1 1pc	2 1pc	3 1pc
4 1pc	5 1pc	6 1pc	7 1pc	8 1pc	9 1pc	10 1pc	11 2pcs	12 2 pcs	13 3pcs
14 1pc									

Step 1

A1 16pcs

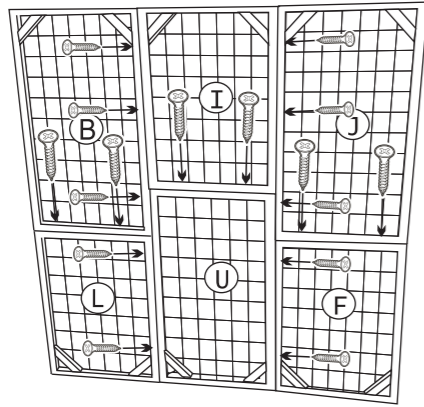

Step 2

A1 12pcs
A2 10pcs

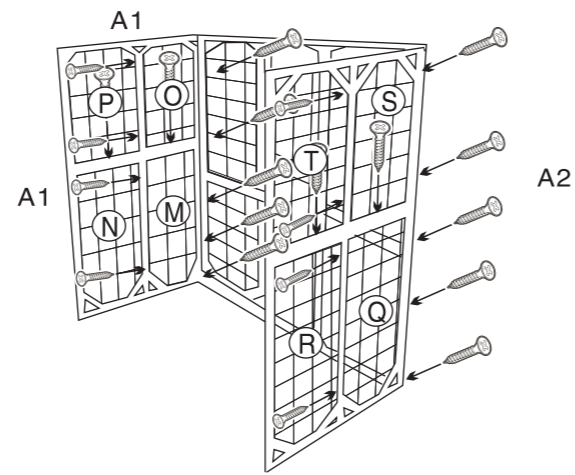

Step 3

A4 20pcs

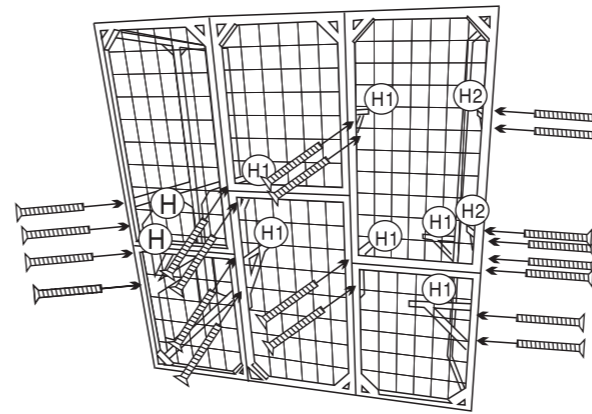

Step 4

A3 20pcs

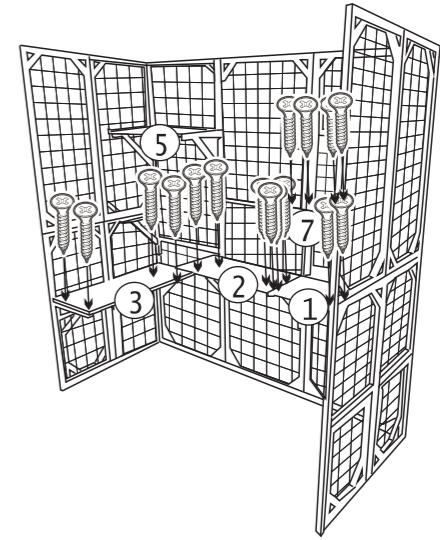

Step 5

A2 4pcs
A3 4pcs

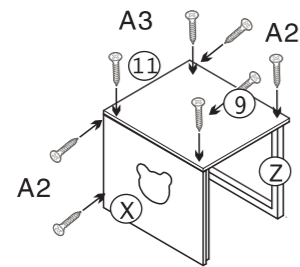

Step 6

A2 4pcs
A3 4pcs

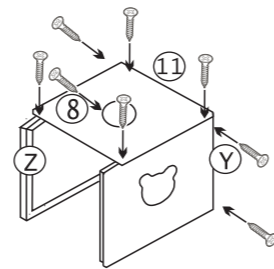

Step 7

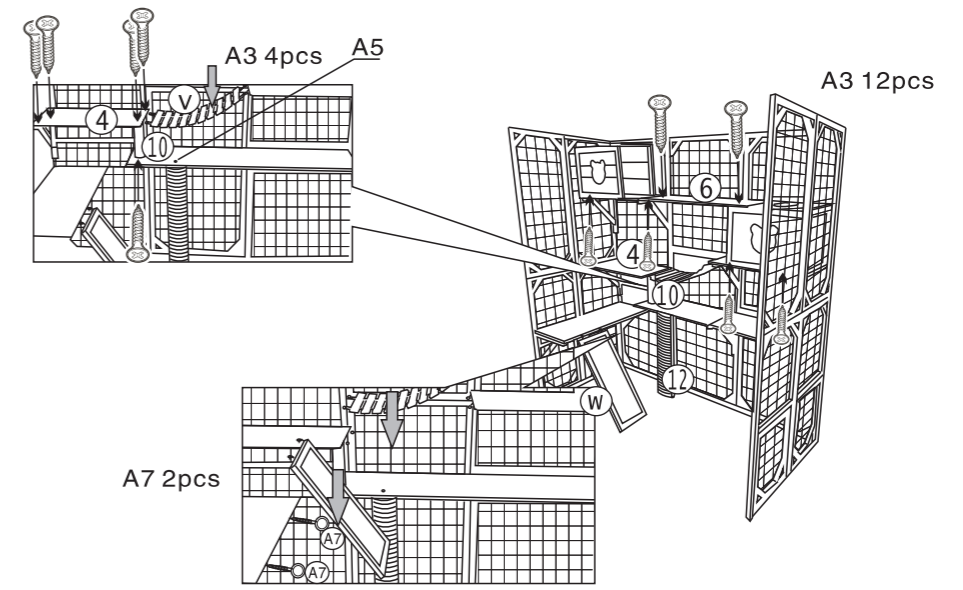

Step 8

A1 16pcs

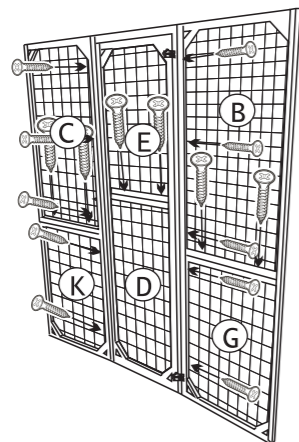

Step 9

A2 10pcs

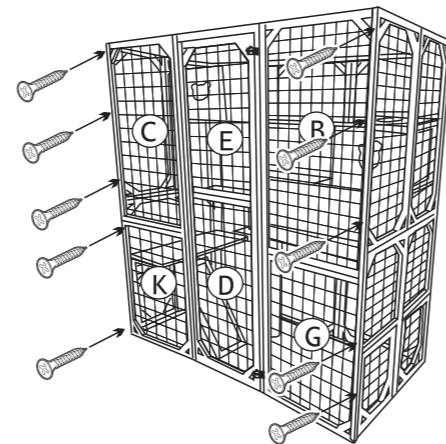

Step 10

A3 14pcs

