

Assembly Instruction

Parts/Hardware list

A	Legs	4 PCS	D	Wrench	1 PC
B	Top Frame	1 PC	E	Felt pad	4 PCS
C	Small Frame	2 PCS	F	Big Glass	1 PC
G	Small Glass	2 PCS	H	Screw	16 PCS

1. Take the parts carefully out of the carton, and place them on a flat and soft surface, making sure that the parts will not be damaged.
2. Place Top Frame(B) upside down on clean, flat, and soft surface.
3. Assemble Legs (A) on the Top Frame (B) by using 8 screws.
4. Assemble one of Small Frame (C) on the middle position of Legs (A) by using 4 screws. Make sure the side with welding spots face to feet.
5. Assemble another Small Frame (C) near feet position of Legs (A) by using 4 screws. Make sure the side with welding spots face to feet.
6. Use wrench that supplied in part bag to tight all screws.
7. Stick the Felt pad (E) on the bottom of feet of the Legs (A).
8. Turn over table, place the big Glass (F) on Top Frame (B) and Small Glasses (G) on two Small Frames (C) individually.

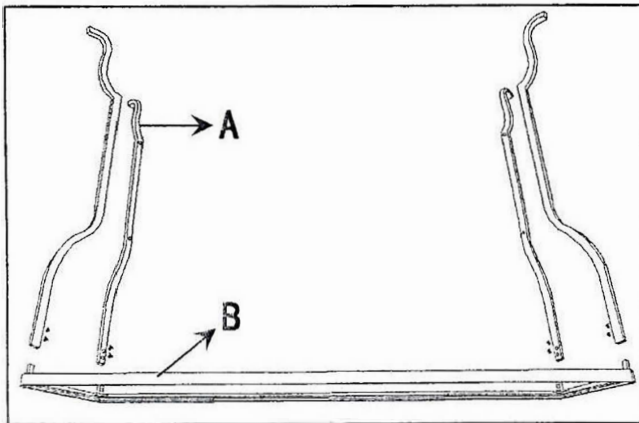

(1)

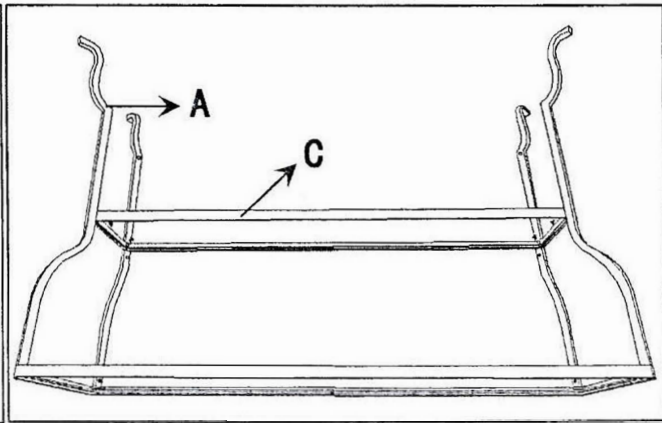

(2)

9. Softly clean & wipe with dry cloth.

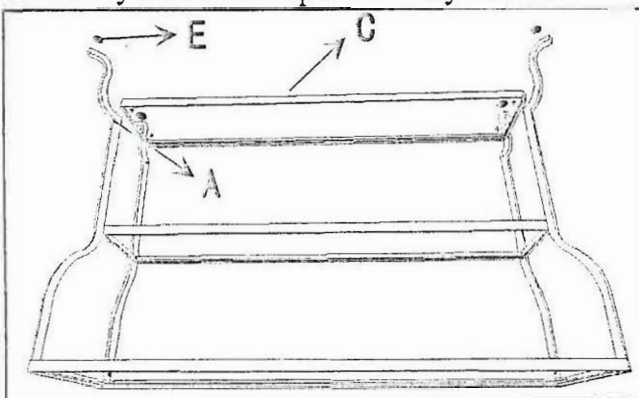

(3)

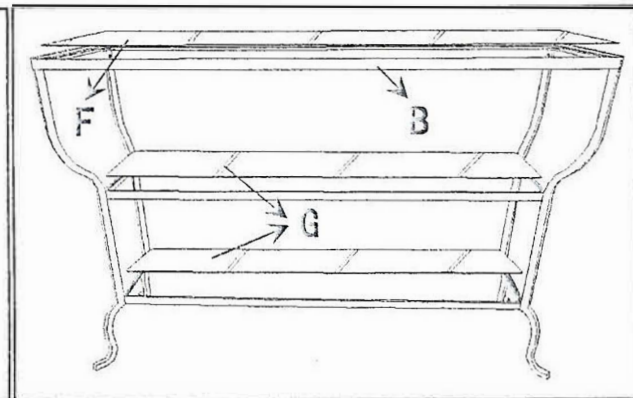

(4)