

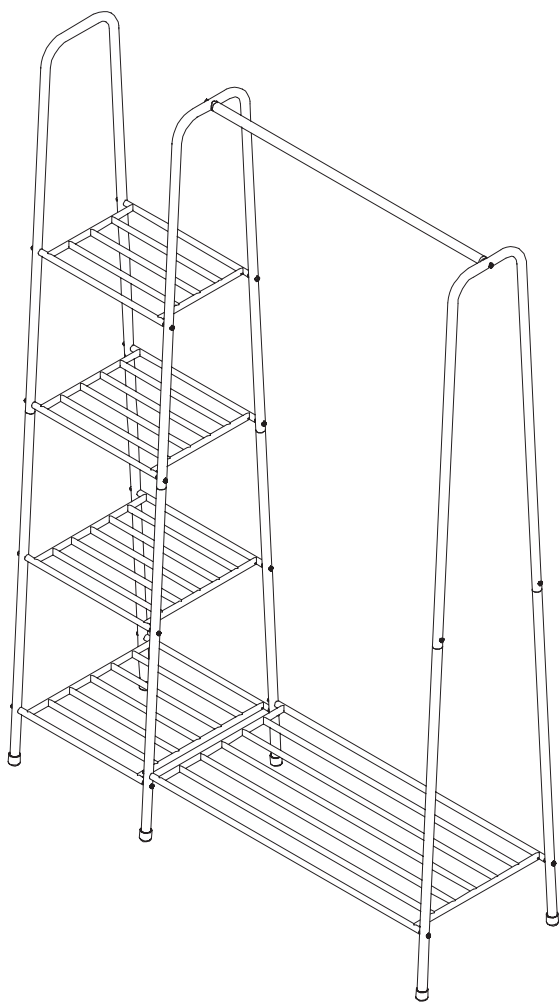



# wardrobe





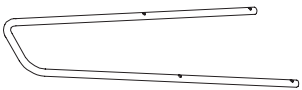
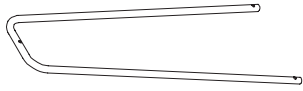

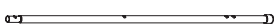
**45 in L x 15 in W x 66 in H**

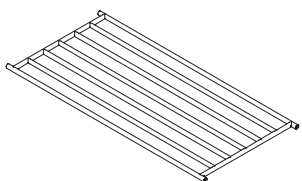
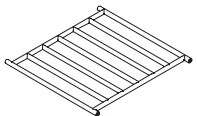
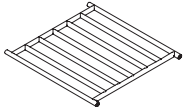
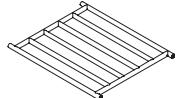
---

# PARTS LIST

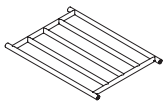
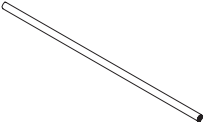
PART/ILLUSTRATION	(QTY)	DESCRIPTION
<b>A</b> 	(1)	top shelf supports
<b>B</b> 	(1)	top shelf supports
<b>C</b> 	(1)	top shelf supports
<b>D</b> 	(2)	bottom shelf supports
<b>E</b> 	(2)	bottom shelf supports
<b>F</b> 	(2)	bottom shelf supports
<b>G</b> 	(1)	shelf
<b>H</b> 	(1)	shelf
<b>I</b> 	(1)	shelf
<b>J</b> 	(1)	shelf

# PARTS LIST

PART/ILLUSTRATION	(QTY)	DESCRIPTION
<b>K</b> 	(1)	shelf
<b>L</b> 	(1)	horizontal bar
<b>M</b> 	(22)	long screws
<b>N</b> 	(2)	short screws
<b>O</b> 	(2)	plastic caps
<b>P</b> 	(1)	hex wrench

# ASSEMBLY

1

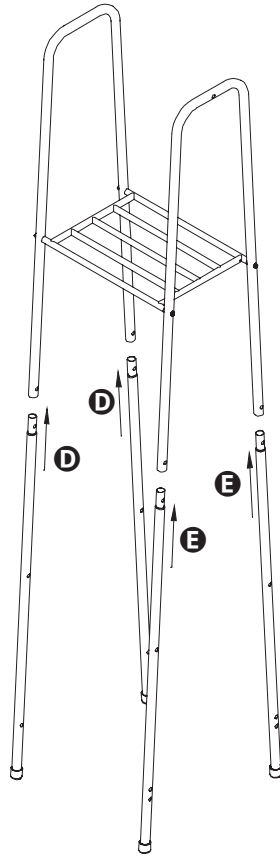
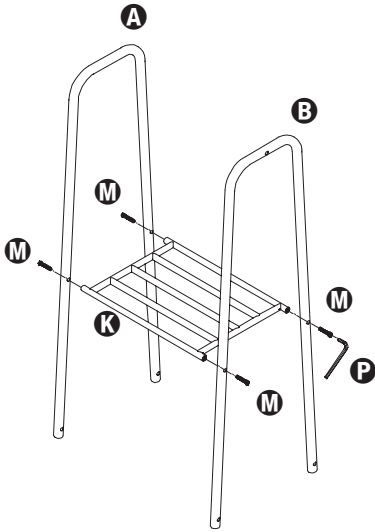

# ASSEMBLY

2

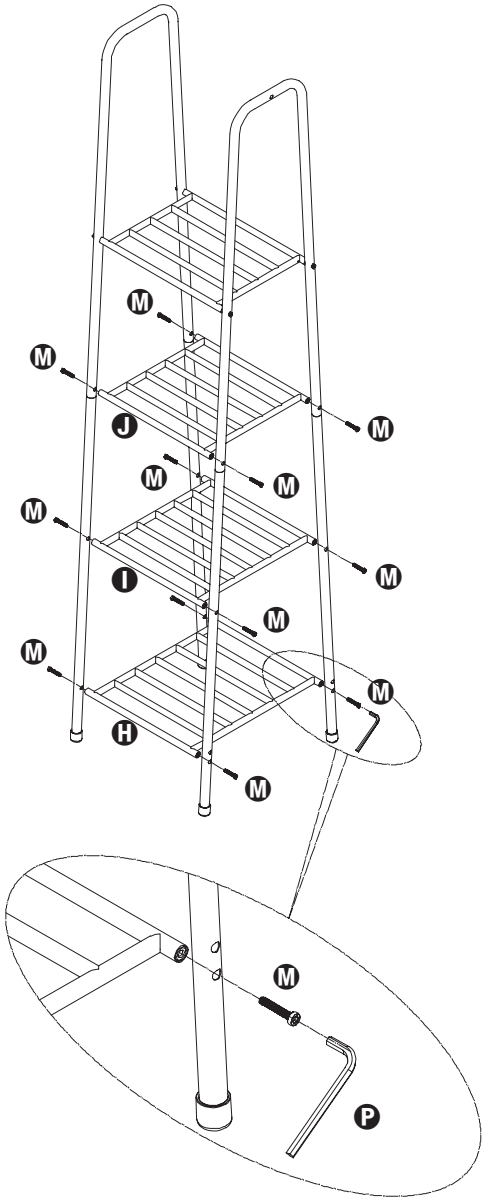

# ASSEMBLY

3

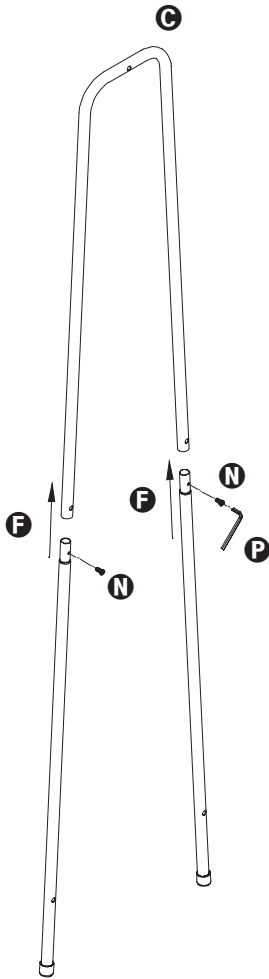

# ASSEMBLY

4

