

## ASSEMBLY INSTRUCTION

### 024-636 CECIL OVAL BACK UPH SIDE CHAIR

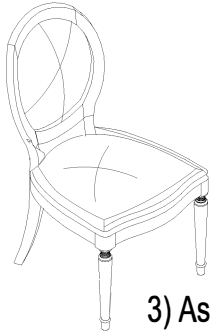

3) Assembly is completed.

### IMPORTANT NOTES :

- . Place all wooden parts on a clean and smooth surface such as a rug or carpet to prevent the parts from being scratched.
- . Check to be sure that you have all parts and hardware.
- . Remove all wrapping materials, including staples and packing straps before you start to assemble.
- . Do not tighten all screws and bolts until completely assembled.
- . Keep all hardware out of the reach of children.

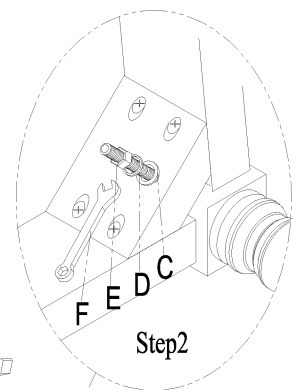
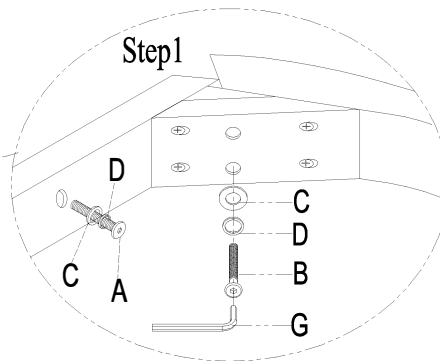
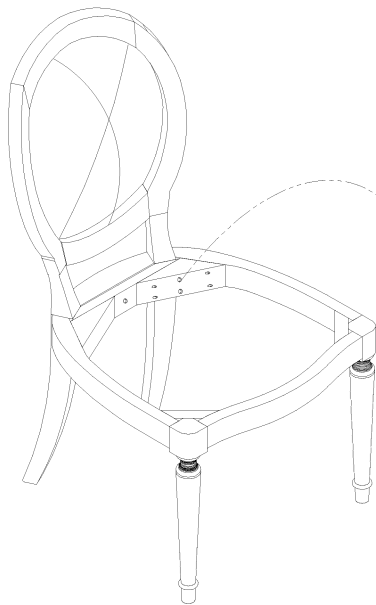

| NO. | Dimension              | Shape | Quantity |
|-----|------------------------|-------|----------|
| A   | Bolt 5/16"*38mm        |       | 1pc      |
| B   | Bolt 5/16"*76mm        |       | 4pcs     |
| C   | Flat washer 5/16"*19mm |       | 9pcs     |
| D   | Lock washer 5/16"      |       | 9pcs     |
| E   | Nut 5/16"              |       | 4pcs     |
| F   | Wrench 12mm            |       | 1pc      |
| G   | Allen Key 4mm          |       | 1pc      |