

# Instruction Manual

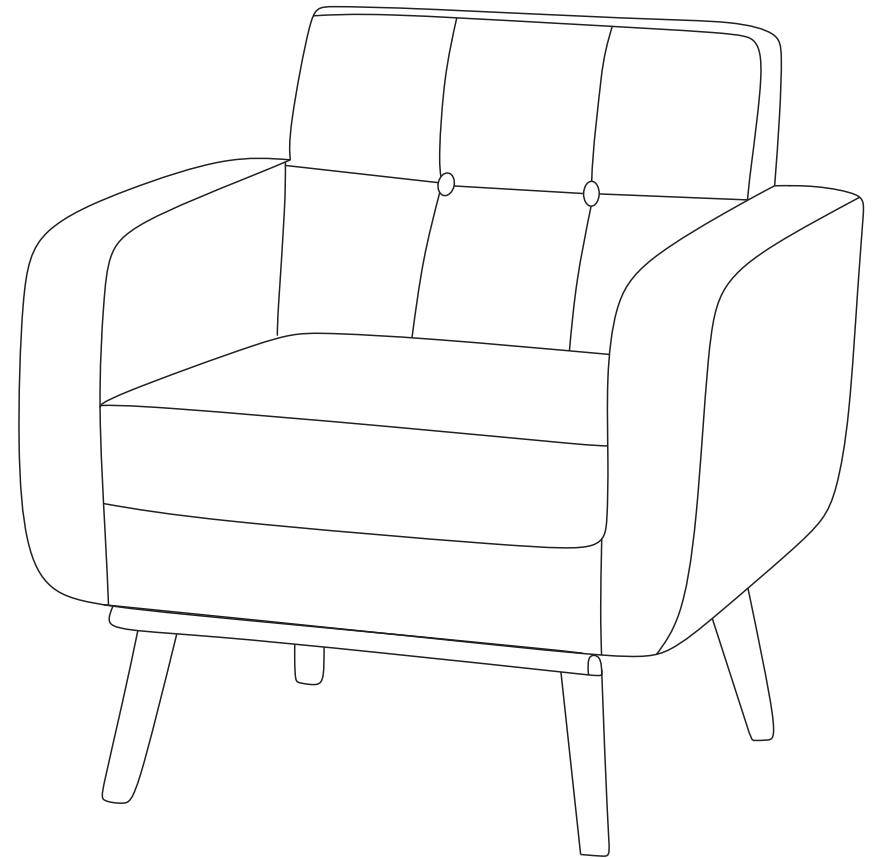





## User Guide

### Make life better

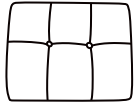
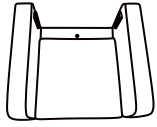
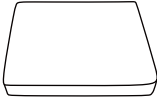
Warm tips: We are proud of high-quality products and satisfactory service, but the goods may encounter special circumstances during transportation, if you receive the goods with missing or damaged parts, please take photos and contact our customer service before returning the goods , we will customize a solution that satisfies you, thank you.

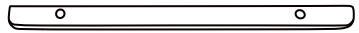
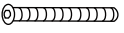
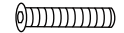

# Instruction

NO	DESCRIPTION		QTY
A	Backrest		1
B	Saddle Frame		1
C	Cushion		1
D	leg		4
E	Front rung		1
F	Screw1	$\Phi 5/16'' \times 3-15/16''L$ 	1
G	Screw2	$\Phi 5/16'' \times 2''L$ 	10
H	Flat Washer	$\Phi 5/16'' \times 2mm$ 	9
I	Lock Washer	$\Phi 5/16''$ 	9
J	Black Flat Washer	$\Phi 1.5mm$ 	2
K	Allen Wrench	$\Phi 5mm$ 	1

## Note:

1. During the assembly process of a product, if you need to install multiple screws, you can first align all the screws with the holes, first rotate a few times to fix the positions of all the screws. and after all the screws are aligned with the holes, use a wrench to completely tighten in turn.

2. Flat washers and lock washers must be installed to prevent the screws from loosening and damaging the joints

# Installation Method

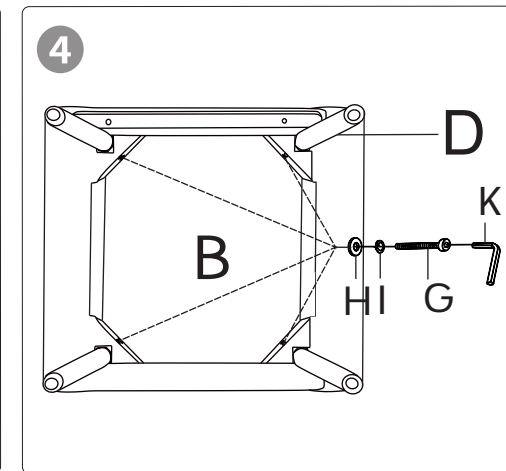
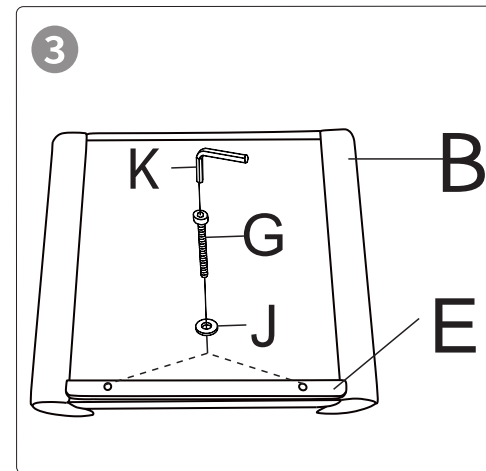
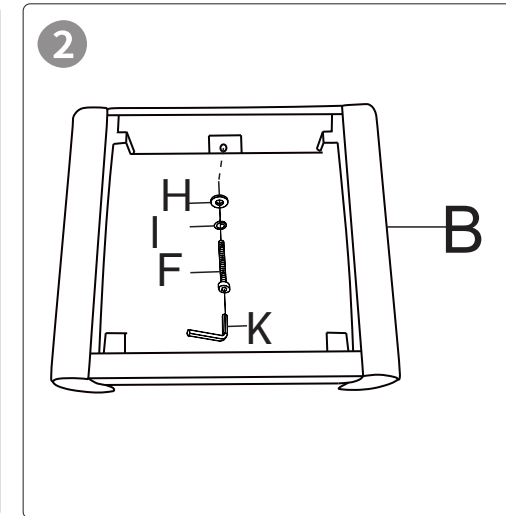
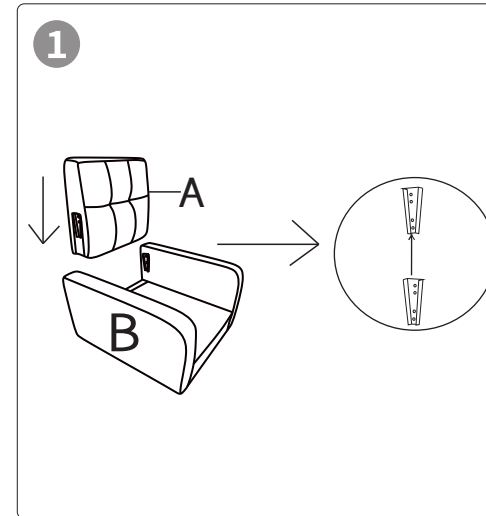

- 1 Align the backrest A with the seat frame B and align the left and right metal parts to ensure that they are firmly in place.
- 2 Use parts (H-I-F) to tighten the screws connecting the backrest at the bottom of the seat frame B.
- 3 Use parts (H-I-F) to tighten the screws connecting the backrest at the bottom of the seat frame B.
- 4 Use parts (H-I-G) to insert and install the four legs and tighten them separately.