

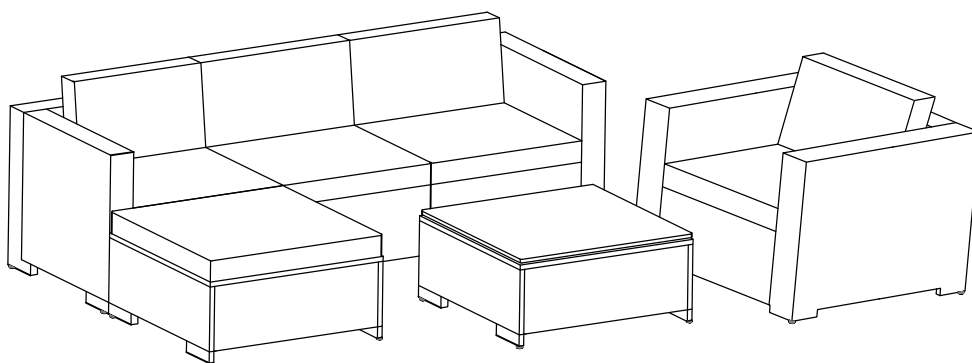

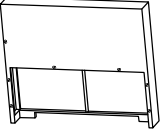

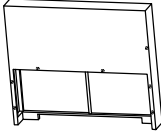

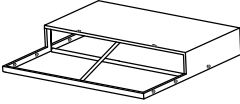

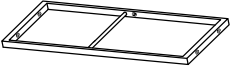
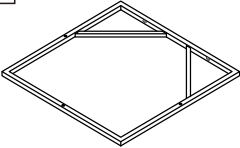
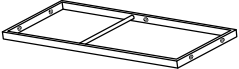
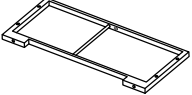
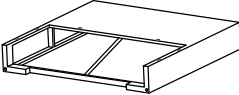
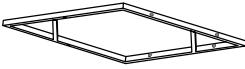
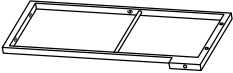
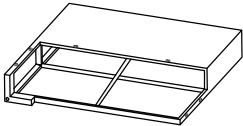
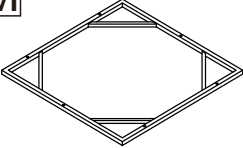
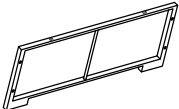
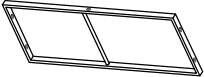
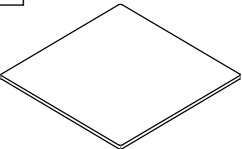

6 Piece Wicker Sofa Set

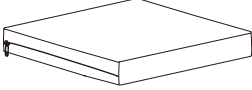

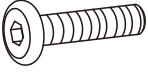
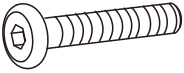



PART LIST

<p>A</p>  <p>(arm & corner chair)</p>	<p>B</p>  <p>(arm chair)</p>	<p>C</p>  <p>(arm chair)</p>	<p>D</p>  <p>(arm chair)</p>	<p>E</p>  <p>(arm chair)</p>
<p>Right Arm Panel 3 PCS</p>	<p>Left Arm Panel 1 PC</p>	<p>Back Panel 1 PC</p>	<p>Seat Panel 1 PC</p>	<p>Front Panel 1 PC</p>
<p>F</p>  <p>(armless chair)</p>	<p>G</p>  <p>(armless & corner chair)</p>	<p>H</p>  <p>(armless chair)</p>	<p>I</p>  <p>(armless chair)</p>	<p>J</p>  <p>(corner chair)</p>
<p>Seat Panel 1 PC</p>	<p>Side Panel 4 PCS</p>	<p>Front Panel 1 PC</p>	<p>Back Panel 1 PC</p>	<p>Seat Panel 2 PCS</p>
<p>K</p>  <p>(corner chair)</p>	<p>L</p>  <p>(corner chair)</p>	<p>M</p>  <p>(coffee table & ottoman)</p>	<p>N</p>  <p>(coffee table & ottoman)</p>	<p>O</p>  <p>(coffee table & ottoman)</p>
<p>Side Panel 2 PCS</p>	<p>Back Panel 2 PCS</p>	<p>Wicker Top 2 PCS</p>	<p>Side Panel 4 PCS</p>	<p>Side Panel 4 PCS</p>
<p>P</p>  <p>(coffee table)</p>	<p>X</p>  <p>(armless\corner chair and arm chair)</p>	<p>Y</p>  <p>(armless\corner chair and arm chair)</p>	<p>Z</p>  <p>(ottoman)</p>	
<p>Glass Top 1 PC</p>	<p>Seat Cushion 4 PCS</p>	<p>Back Cushion 4 PCS</p>	<p>Seat Cushion 1 PC</p>	

HARDWARE LIST

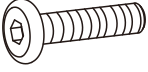
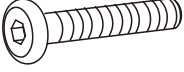
<p>Q</p>  <p>M6*30mm</p>	<p>R</p>  <p>M6*50mm</p>	<p>S</p>  <p>M6mm</p>	<p>T</p>  <p>M6mm</p>	<p>U</p>  <p>M6mm</p>
<p>Bolt 44 PCS</p>	<p>Long Bolt 44 PCS</p>	<p>Flat Washer 132 PCS</p>	<p>Hex Nut 44 PCS</p>	<p>Allen Wrench 2 PCS</p>
<p>V</p>  <p>M6mm</p>	<p>W</p>  <p>M6mm</p>			
<p>Wrench 2 PCS</p>	<p>Adjustable Leveler 24 PCS</p>			





EXTRA HARDWARE LIST

<p>Q</p>  <p>M6*30mm</p>	<p>R</p>  <p>M6*50mm</p>	<p>S</p>  <p>M6mm</p>	<p>T</p>  <p>M6mm</p>	<p>W</p>  <p>M6mm</p>
<p>Bolt 3 PCS</p>	<p>Long Bolt 3 PCS</p>	<p>Flat Washer 5 PC</p>	<p>Hex Nut 3 PCS</p>	<p>Adjustable Leveler 2 PCS</p>

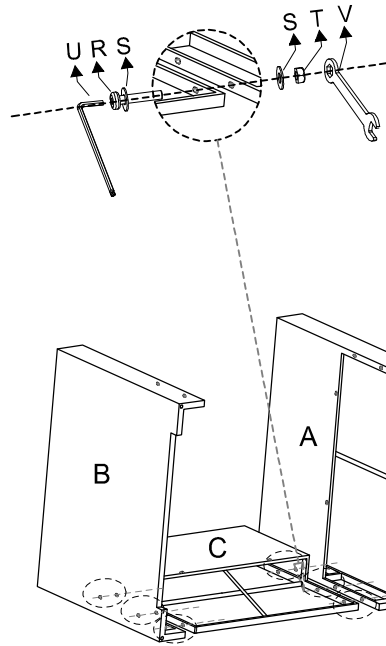
Step 1. Lay back panel (part C) upside down on a soft flat surface, such as carpet, as shown below. Attach right arm panel (part A) and left arm panel (part B) to back panel (part C) using long bolts (part R), flat washers (part S), hex nuts (part T), allen wrench (part U) and wrench (part V).

NOTE: Please do not fully tighten bolts until unit is fully assembled.





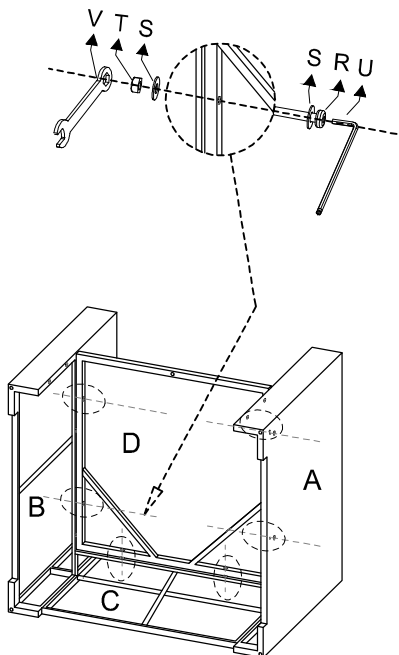

R		x6
S		x12
T		x6
U		x1
V		x1

Step 2. Attach seat panel (part D) to right arm panel (part A), left arm panel (part B) and back panel (part C) using long bolts (part R), flat washers (part S), hex nuts (part T), allen wrench (part U) and wrench (part V).

NOTE: Please do not fully tighten bolts until unit is fully assembled.







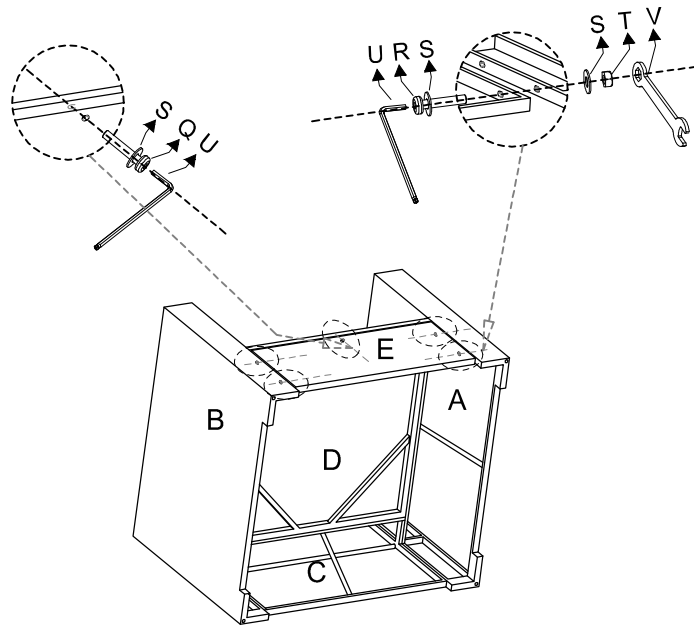

R		x6
S		x12
T		x6
U		x1
V		x1

Step 3. Attach front panel (part E) to right arm panel (part A), left arm panel (part B) and seat panel (part D) using bolt (part Q), long bolts (part R), flat washers (part S), hex nuts (part T), allen wrench (part U) and wrench (part V).

NOTE: Please fully tighten all bolts at this time.



- | | | |
|---|---|----|
| Q |  | x1 |
| R |  | x4 |
| S |  | x9 |
| T |  | x4 |
| U |  | x1 |
| V |  | x1 |

Step 4. Screw adjustable levelers (part W) to desired position in the pre-drilled holes on the bottom of unit.

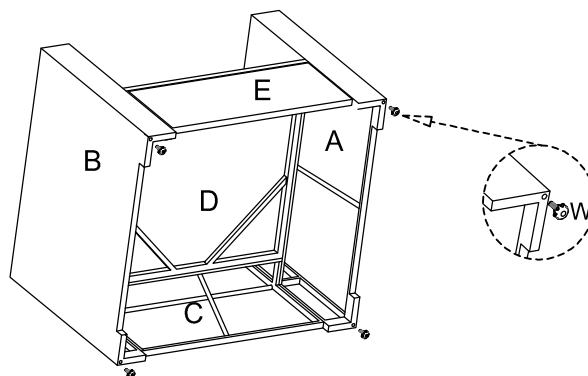

- | | | |
|---|---|----|
| W |  | x4 |
|---|---|----|

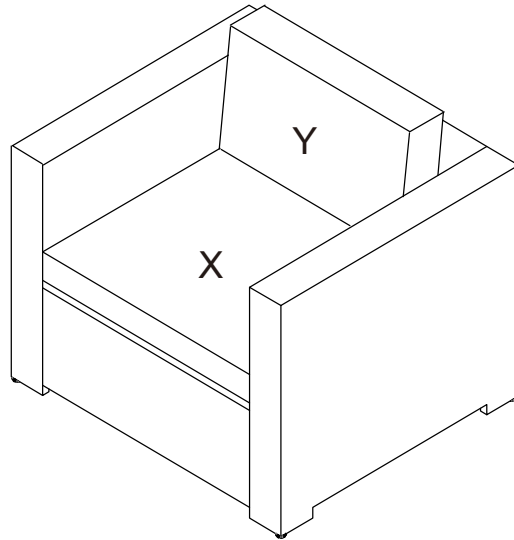

Step 5. Carefully turn the assembled unit upright. Add seat cushion (part X) and back cushion (part Y) as shown below.

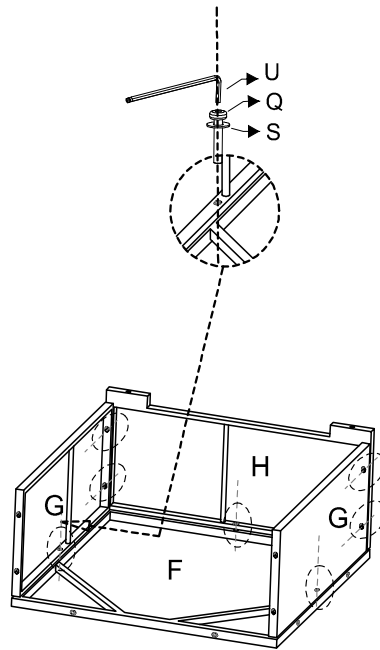

Step 6. Lay seat panel (part F) upside down on a soft flat surface, such as carpet, as shown below. Attach side panels (part G) and front panel (part H) to seat panel (part F) using bolts (part Q), flat washers (part S) and allen wrench (part U).

NOTE: Please do not fully tighten bolts until unit is fully assembled.





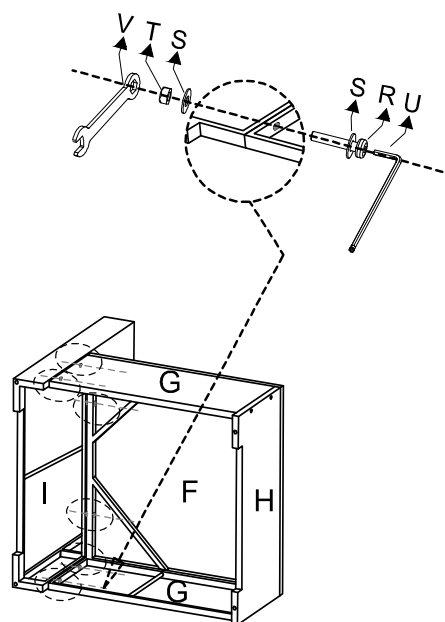

Q		x7
S		x7
U		x1

Step 7. Attach assembled unit (parts F, G, & H) to back panel (part I) using long bolts (part R), flat washers (part S), hex nuts (part T), allen wrench (part U) and wrench (part V).

NOTE: Please fully tighten all bolts at this time.



R		x6
S		x12
T		x6
U		x1
V		x1

Step 8. Screw adjustable levelers (part W) to desired position in the pre-drilled holes on the bottom of unit.

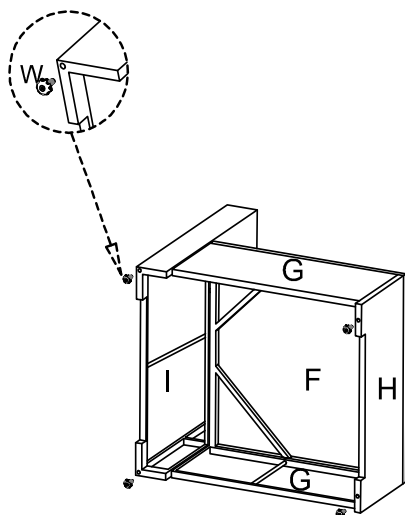

W  x4

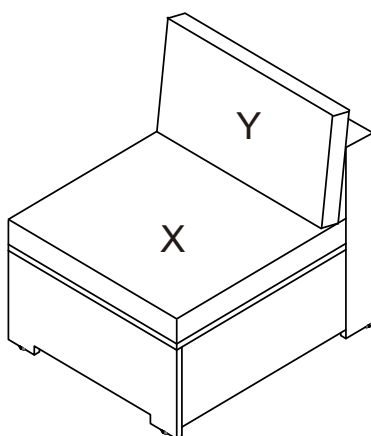

Step 9. Carefully turn the assembled unit upright. Add seat cushion (part X) and back cushion (part Y) as shown below.

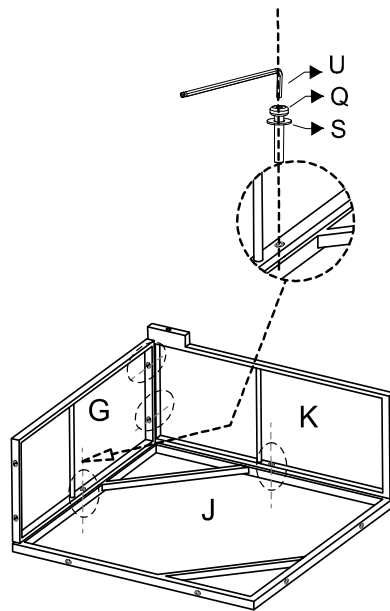

Step 10. Lay seat panel (part J) upside down on a soft flat surface, such as carpet, as shown below. Attach side panel (part G) and side panel (part K) to seat panel (part J) using bolts (part Q) flat washers (part S) and allen wrench (part U).

NOTE: Please do not fully tighten bolts until unit is fully assembled.





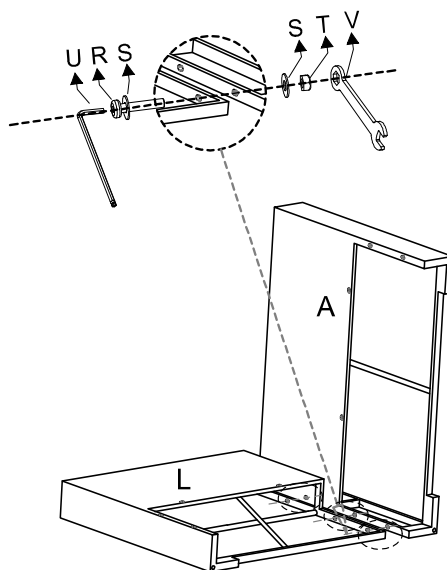

Q		x4
S		x4
U		x1

Step 11. Attach back panel (part L) to right arm panel (part A) using long bolts (part R), flat washers (part S), hex nuts (part T), allen wrench (part U) and wrench (part V).

NOTE: Please do not fully tighten bolts until unit is fully assembled.





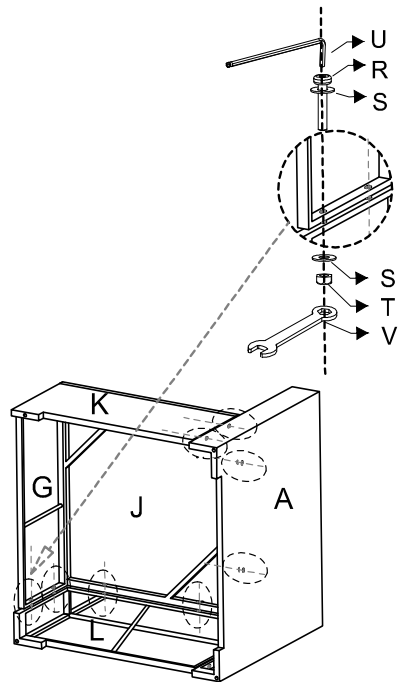

R		x3
S		x6
T		x3
U		x1
V		x1

Step 12. Attach assembled unit (parts G, J & K) to right arm panel (part A) and back panel (part L) using long bolts (part R), flat washers (part S), hex nuts (part T), allen wrench (part U) and wrench (part V).

NOTE: Please fully tighten all bolts at this time.



R		x8
S		x16
T		x8
U		x1
V		x1

Step 13. Screw adjustable levelers (part W) to desired position in the pre-drilled holes on the bottom of unit.

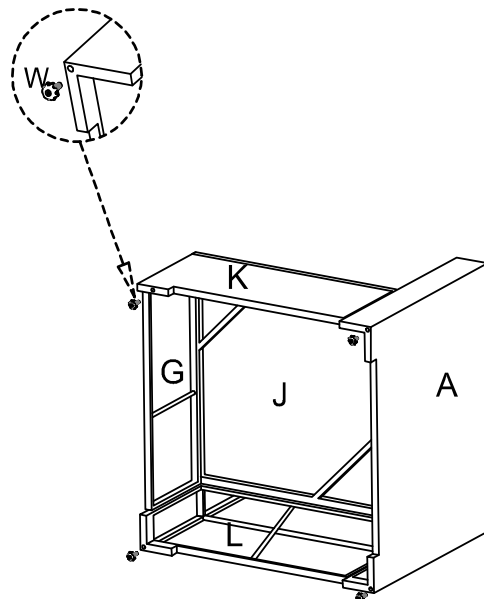

W		x4
---	---	----

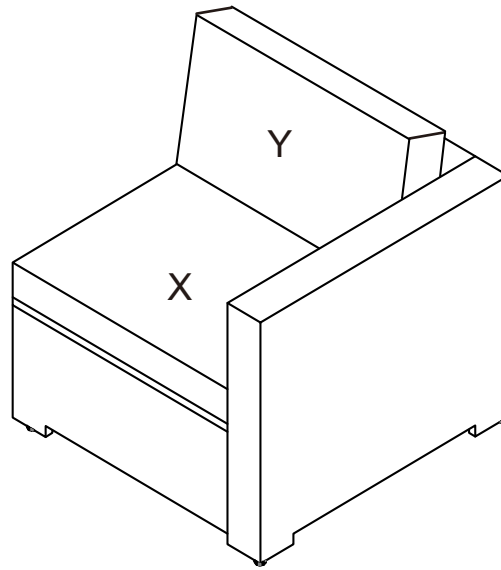

Step 14. Carefully turn the assembled unit upright. Add seat cushion (part X) and back cushion (part Y) as shown below. Repeat steps 10-14 to assemble remaining corner chair.

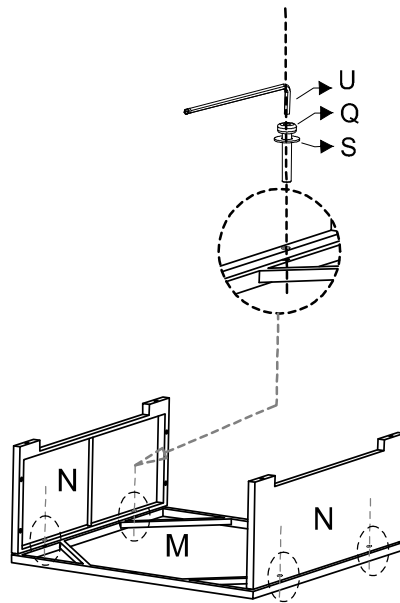

Step 15. Lay wicker top (part M) upside down on a soft flat surface, such as carpet, as shown below. Attach side panels (part N) to wicker top (part M) using bolts (part Q), flat washers (part S) and allen wrench (part U).

NOTE: Please do not fully tighten bolts until unit is fully assembled.





Q		x4
S		x4
U		x1

Step 16. Attach side panels (part O) to wicker top (part M) and side panels (part N) using bolts (part Q), flat washers (part S) and allen wrench (part U).

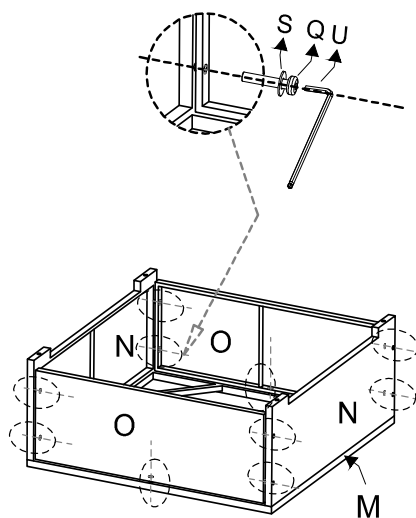
NOTE: Please fully tighten all bolts at this time.



Q		x10
S		x10
U		x1

Step 17. Screw adjustable levelers (part W) to desired position in the pre-drilled holes on the bottom of unit.

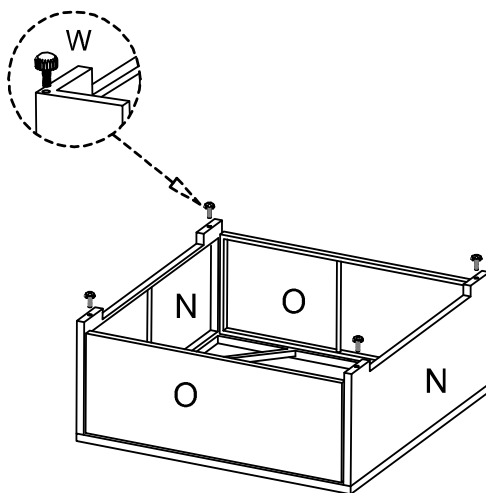

W  x4

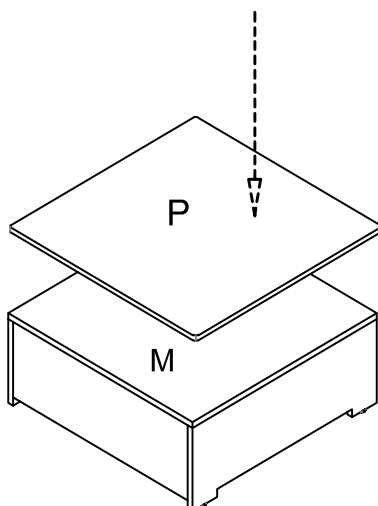

Step 18. Carefully turn the assembled unit upright. Place glass top (part P) on wicker top (part M).

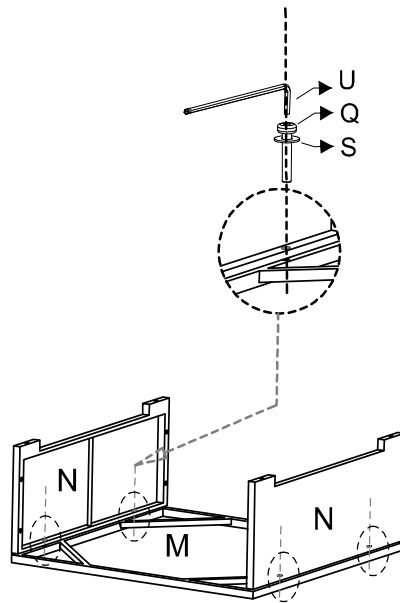

Step 19. Lay wicker top (part M) upside down on a soft flat surface, such as carpet, as shown below. Attach side panels (part N) to wicker top (part M) using bolts (part Q), flat washers (part S) and allen wrench (part U).

NOTE: Please do not fully tighten bolts until unit is fully assembled.





Q		x4
S		x4
U		x1

Step 20. Attach side panels (part O) to wicker top (part M) and side panels (part N) using bolts (part Q), flat washers (part S) and allen wrench (part U).

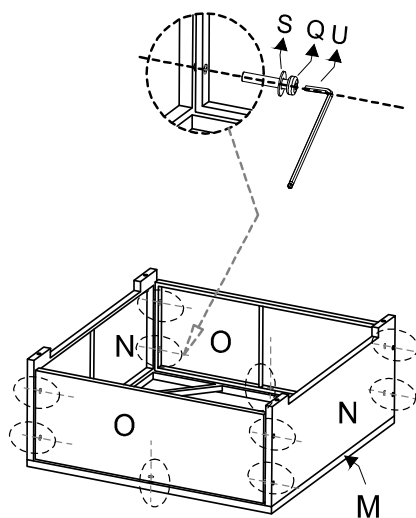
NOTE: Please fully tighten all bolts at this time.



Q		x10
S		x10
U		x1

Step 21. Screw adjustable levelers (part W) to desired position in the pre-drilled holes on the bottom of unit.

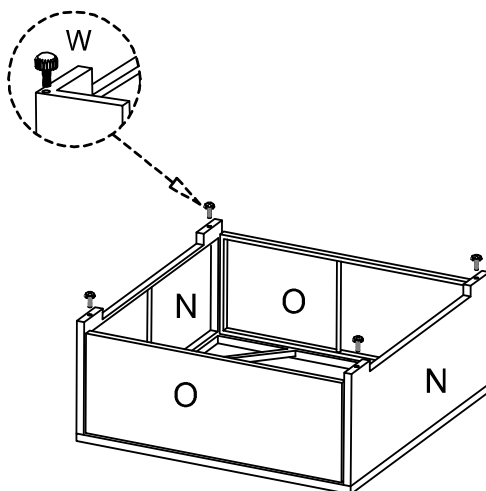

W  x4

Step 22. Carefully turn the assembled unit upright. Add seat cushion (part Z) as shown below.

