

FREESTANDING TUB FILLER ROUGH-IN VALVE

FEATURES

- Solid brass construction
- 1/2" floor mounted valve

COLORS/FINISHES

- N/A

INSTALLATION NOTES

This product is designed for a floor mount installation by a licensed plumbing professional. Please refer to the installation manual for further instructions.

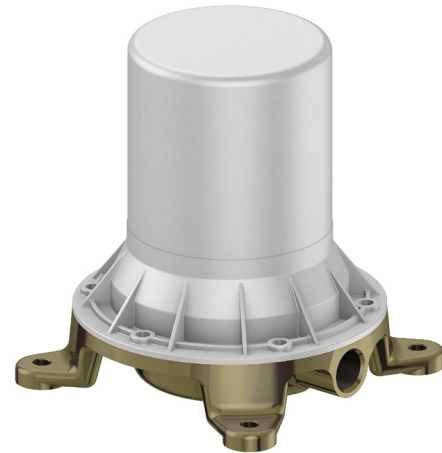

WARRANTY

- Five-year Limited Warranty for residential use
- One-year Limited Warranty for commercial use

SHIPPING INFORMATION

Package Dimensions  
6 11/16" x 6 5/16" x 6 11/16"  
Package Weight  
7.1 lbs

MATERIAL

- Brass

FLOW RATE

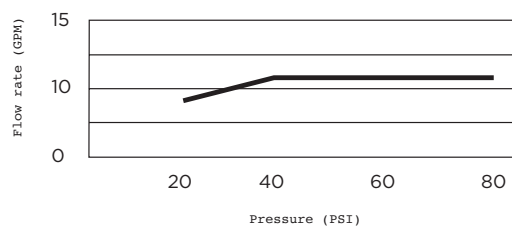

PLEASE NOTE:

Final achievable flow rate is dependent on the outlets fitted, see relevant outlets (spouts, rose, sprays) for assembled product flow rate.

CODES/STANDARDS

- Meets A112.18.1M/A112.18.1
- Certifications: IAPMO(cUPC)



DIMENSIONS

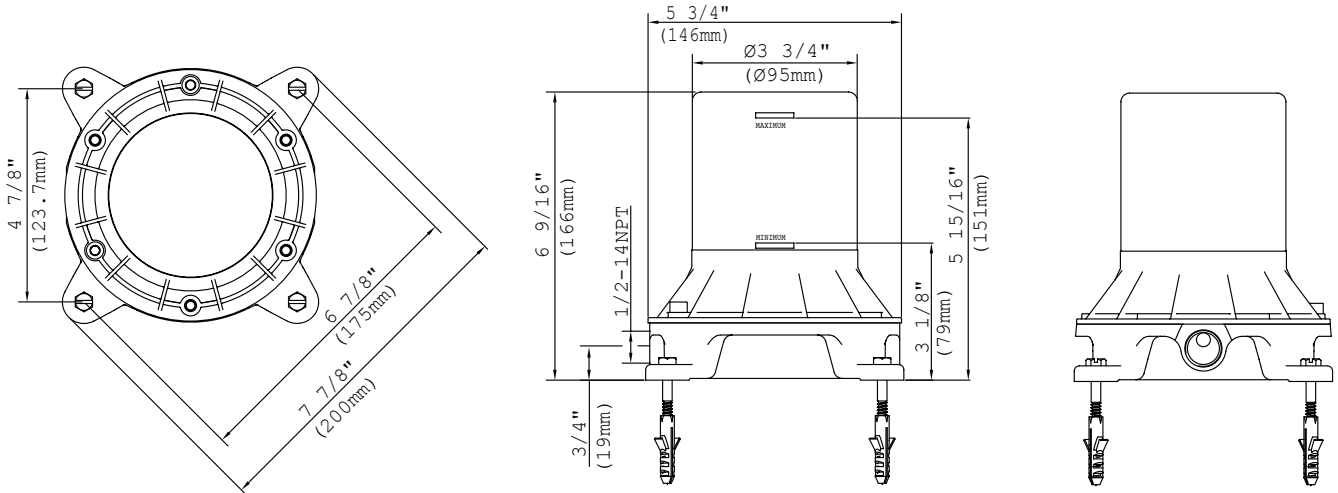

SERVICE PARTS

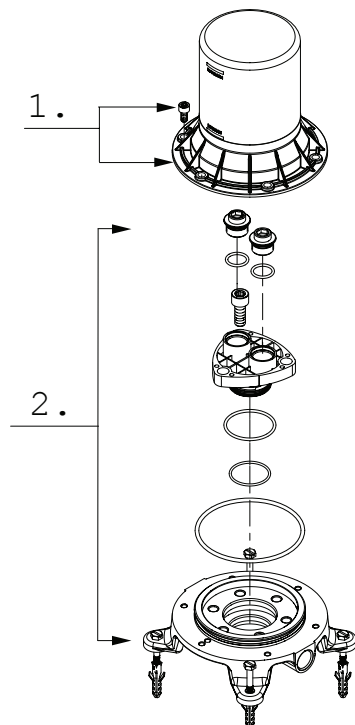

- 1. Protective Cap Assembly (A663A33)
- 2. Body Assembly (A661518)