

Assembly Instructions

Note: Please help to read my instruction before you ready to assemble.

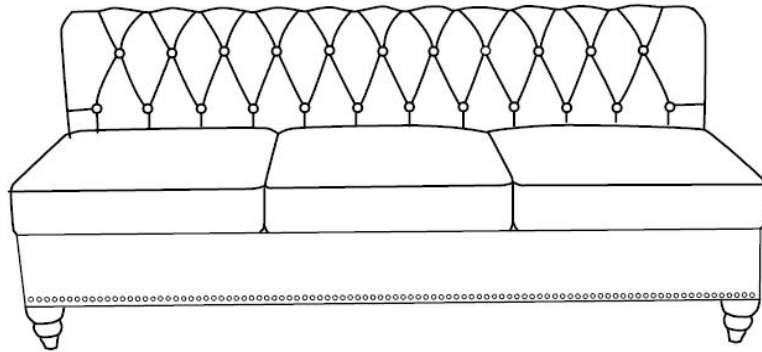



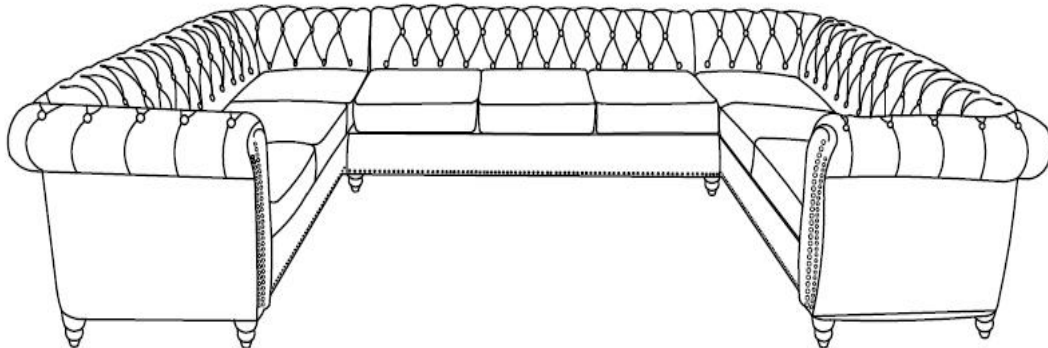

Armless Three Seater Sofa



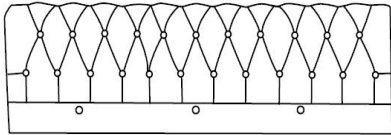

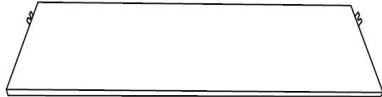

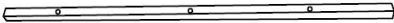



This Armless Three Seater Sofa only can use with two Three Seater Sofas.

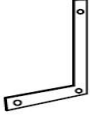

Part List

Label	Picture	Description	QTY (PCS)
A	 A technical drawing of a backrest showing a series of vertical supports connected by a curved top rail, with a base rail and three circular fasteners.	Backrest	1
B	 A technical drawing of a vertical rectangular side panel with four circular fasteners: two at the top and two at the bottom.	Left Side Panel	1
C	 A technical drawing of a vertical rectangular side panel, identical to the left side panel, with four circular fasteners.	Right Side Panel	1
D	 A technical drawing of a rectangular seat with a slightly raised front edge and a small notch on the right side.	Seat	1
E	 A technical drawing of a long, thin horizontal rail with decorative end caps.	Front Rail	1
F	 A technical drawing of a rectangular seat cushion with rounded corners and a slightly raised front edge.	Seat Cushion	3
G	 A technical drawing of a long, thin horizontal wood strip with three circular fasteners spaced evenly along its length.	Wood strip	1
H	 A technical drawing of a single leg, which is a conical shape with a circular top flange and a pointed bottom.	Leg	4









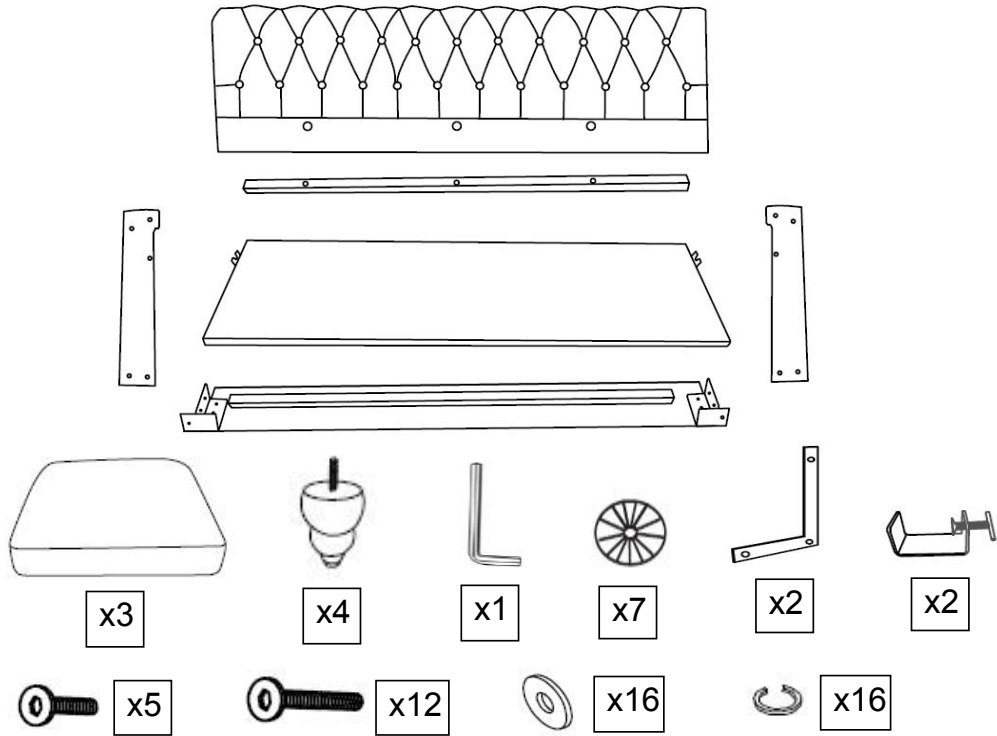

Hardware

①		Plastic Washer	7
②		Allen Wrench	1
③		Iron Stand	2
④		Connecting Piece	2
⑤		Bolt(M8*25MM)	5
⑥		Bolt(M8*50MM)	12
⑦		Flat Washer	16
⑧		Spring Washer	16

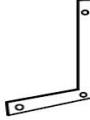
Assembly Preparation

All Including:



 x3
  x4
  x1
  x7
  x2
  x2
 x5
  x12
  x16
  x16

NOTICE:

- Please read the instruction from cover to cover in detail.Thanks.
- Installed by at least two adults
- To avoid damaging your furniture , Please don't assemble on flooring or carpet.
- Please assemble on a clean non-marring surface, example for packing foam.
- Saving all packaging until have finished.

Assembly Steps

OVERVIEW

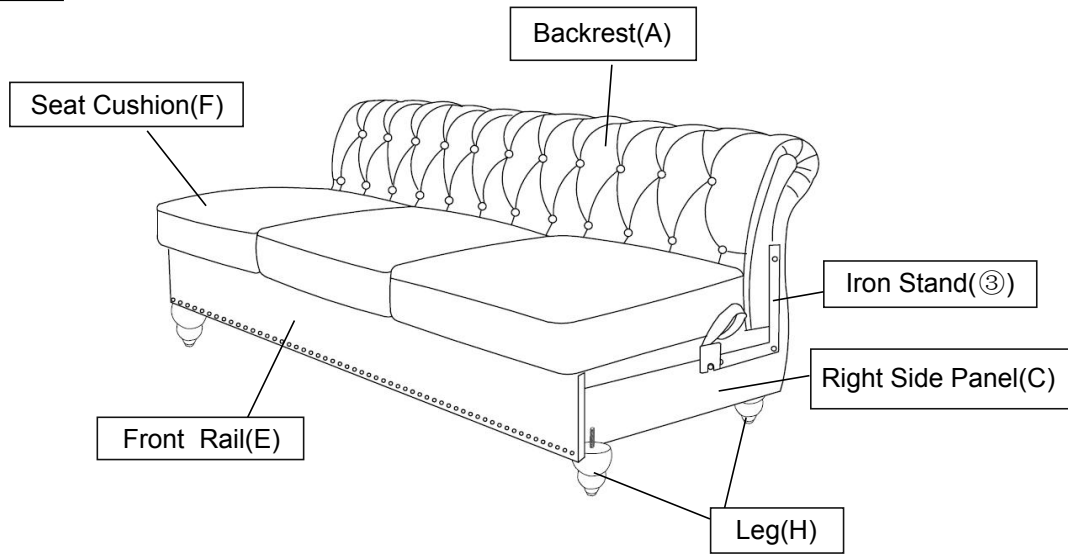

FRONT FACING

This Armless Three Seater Sofa has multiple parts and may require up to 60 minutes to assemble. To give you an overview of the Armless Three Seater Sofa parts, the above picture is to help you put the various parts into perspective. Please read through the instructions below to familiarise yourself with the parts and steps before assembly.

Note: It is recommended that you have an adult partner to assist during the entire assembly process.

Step 1

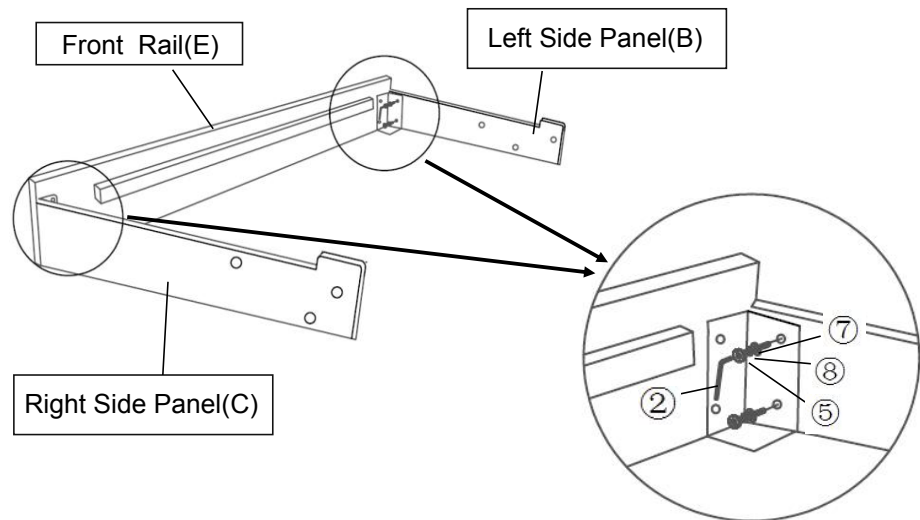

Open the carton and place all the parts on a clean, non-marring surface.
Install the Left Side Panel(B) to the Front Rail(E) by using Bolt(⑤), Spring Washer(⑧), Flat Washer(⑦) with Allen Wrench(②) turning clockwise until tight, repeat the same step with Right Side Panel(C).

Step 2

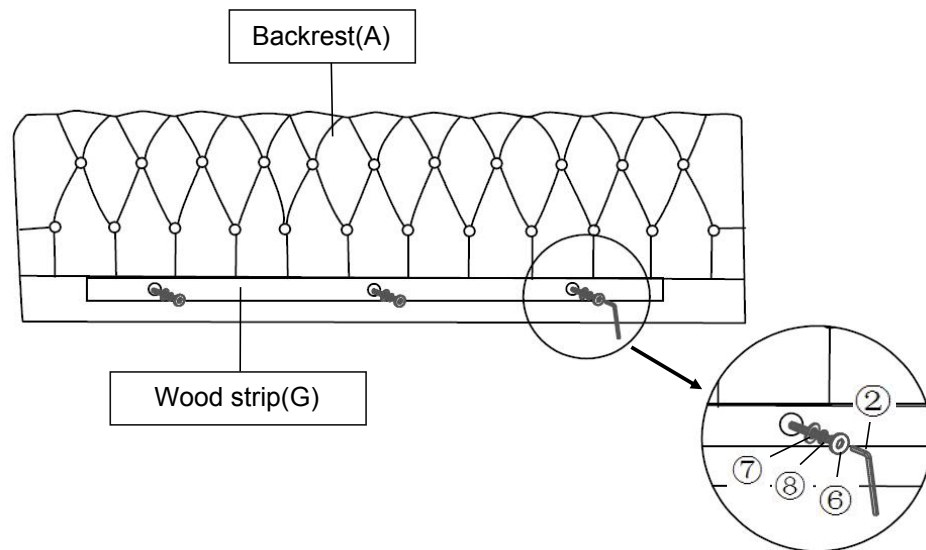

Install the Wood strip(G) on the Backrest(A) by using Bolt(⑥),Spring Washer(⑧),Flat Washer(⑦) with Allen Wrench(②) turning clockwise until tight.

Step 3

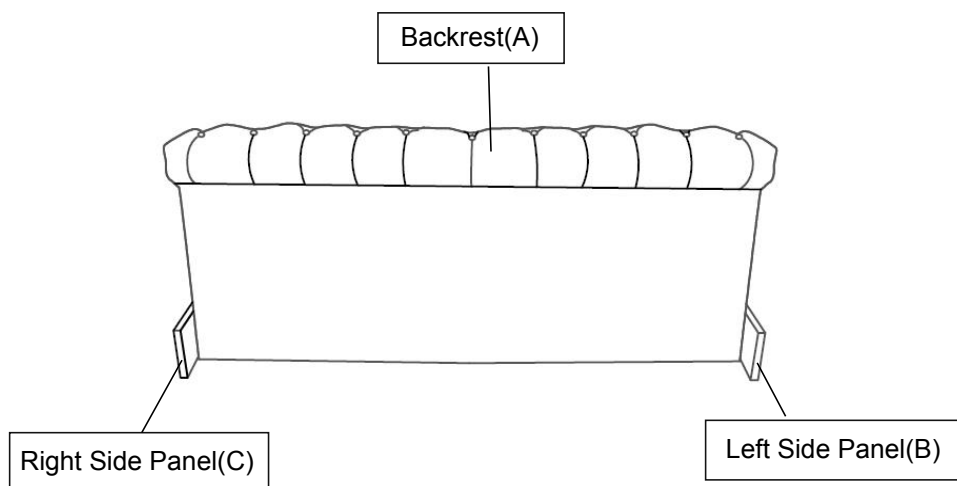

Position the Backrest(A) between Left Side Panel(B) and Right Side Panel(C) as shown in the picture.

Step 4

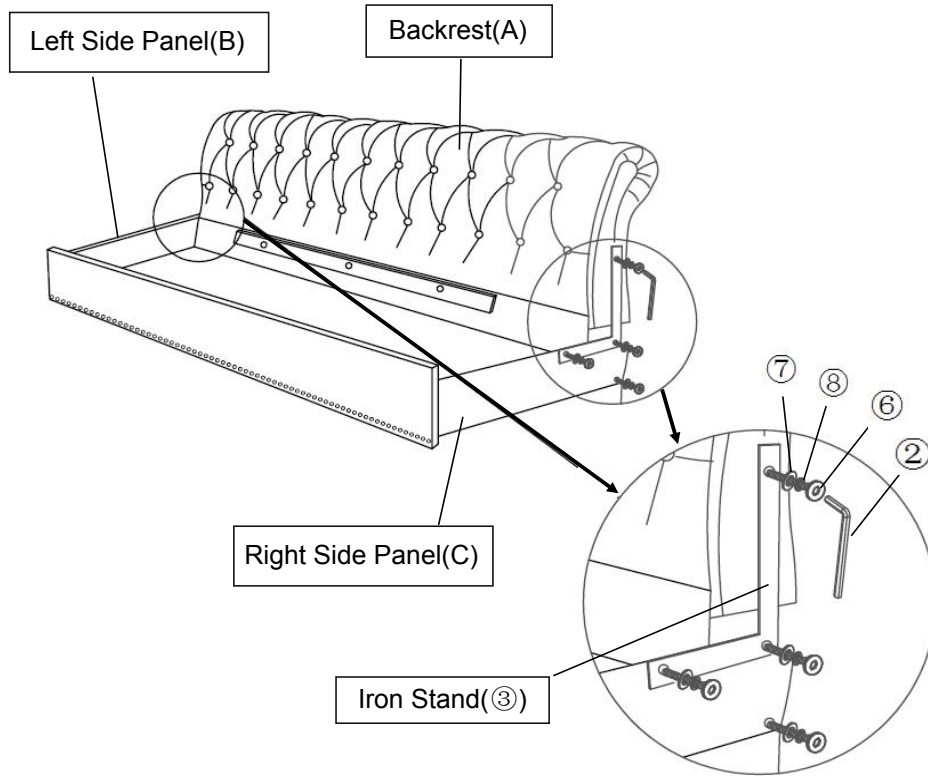

Install the Iron Stand(3) to the Backrest(A) and Right Side Panel(C) by using Bolt(6), Spring Washer(8), Flat Washer(7) with Allen Wrench(2) turning clockwise until tight. Repeat the same step with Backrest(A) and Left Side Panel(B).

Step 5

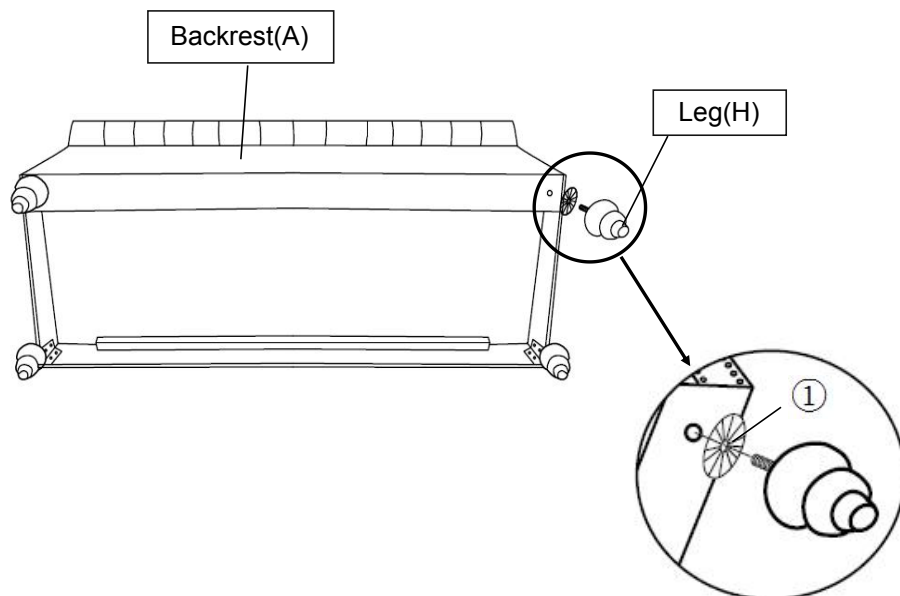

Install the Leg(H) at the bottom of Backrest(A) by placing Plastic Washer(1) on the threaded stem. Then insert threaded stem into the threaded mounting position at the bottom of Backrest(A). Tighten by turning the Leg clockwise.

Note: The use of Plastic Washer(1) are OPTIONAL and are especially useful to help alleviate slight wobbles. Some Legs may need more than one whilst some legs may not need any.

Step 6

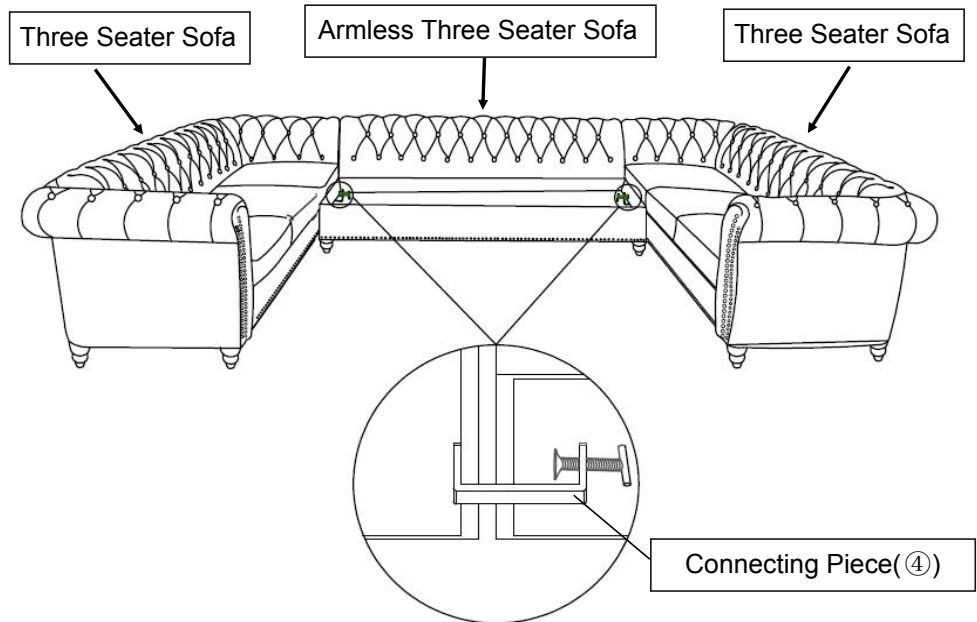

Position the Armless Three Seater Sofa right side up and place it between the two Three Seater Sofa by using Connecting Piece(4).turning clockwise until tight.

Step 7

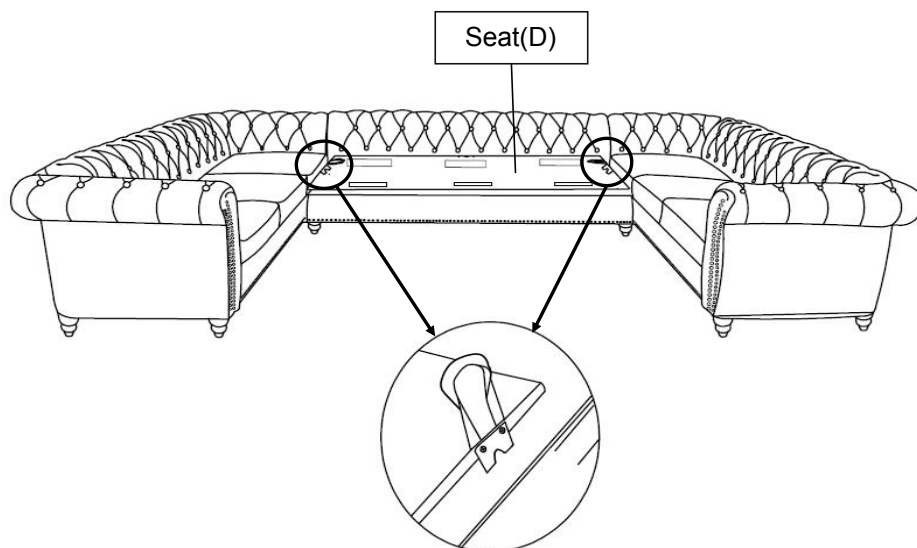

With the assistance of your partner,lift the rope on the two sides of Seat(D) by hand.
Put the Seat(D) on the wood bar of the Front Rail(E) and Backrest(A) then slowly place it down.
Note:The u-shaped iron sheet need clamped to the side panel.

Step 8

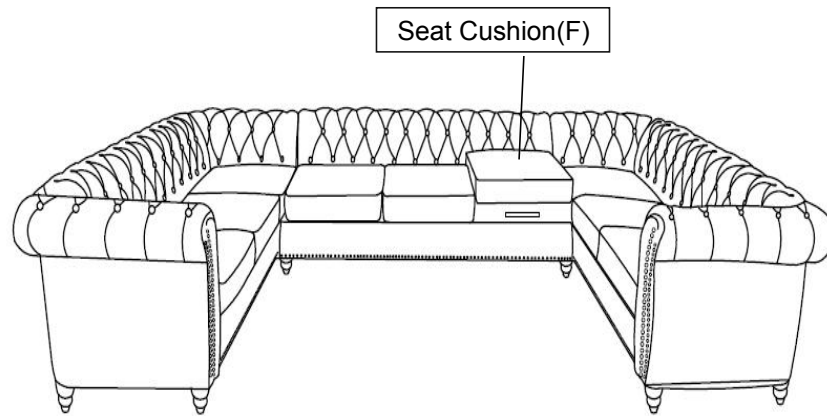

Put the Seat Cushion(F) on the sofa.

Step 9

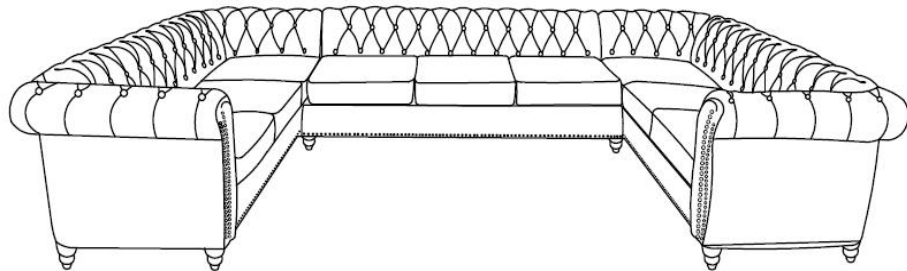

Your Sectional Sofa is ready for use.
This Sectional Sofa can only be used on a flat, level surface.