

Assemble Instruction

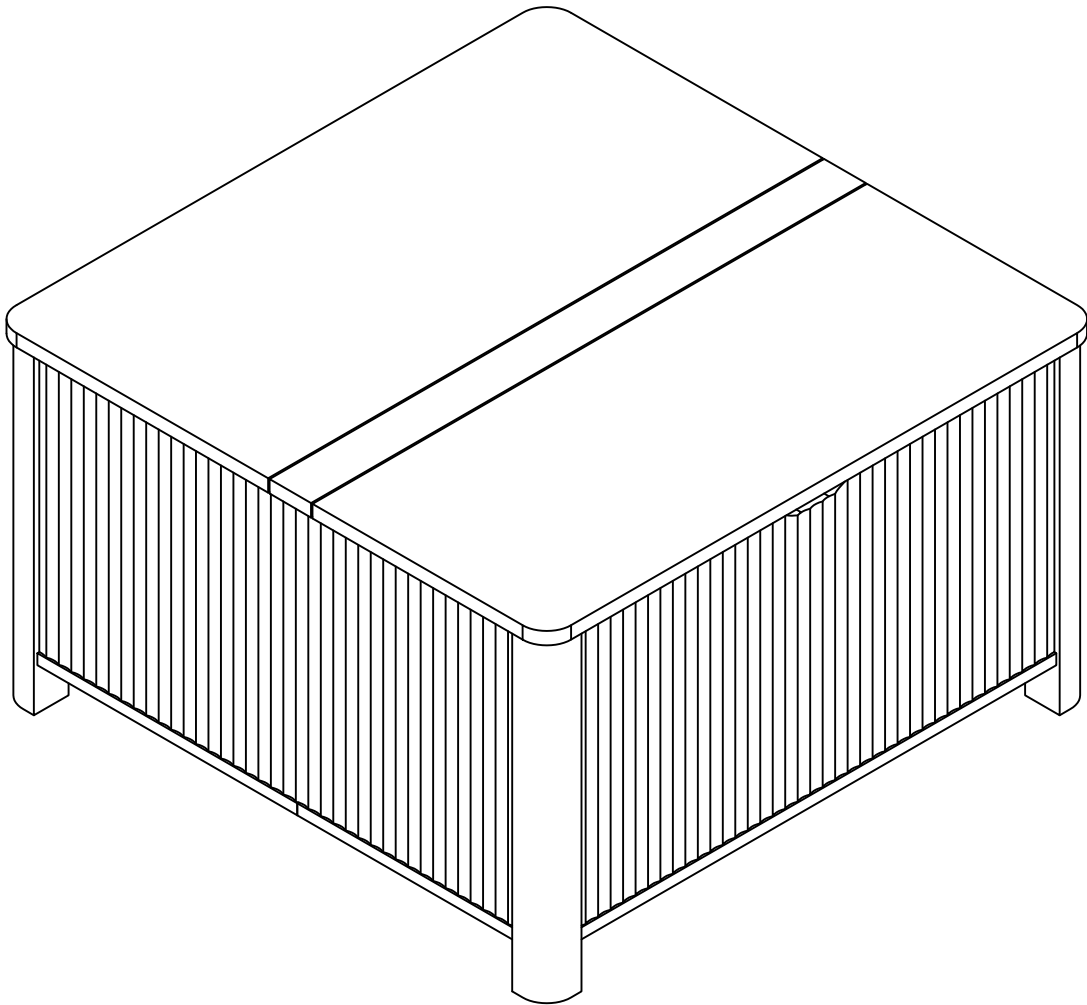

As this item contains many parts, please read the installation instruction carefully before installation . Please use tools properly and carefully. If you have any questions about the product and installation, please contact us.

Before You Start

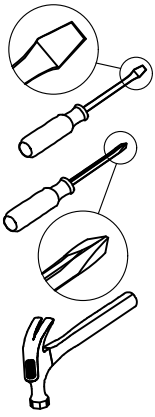

- ✓ Read through each step carefully and follow the proper order
- ✓ Separate and count all your parts and hardware
- ✓ Give yourself enough room for the assembly process
- ✓ Have the following tools: Flat Head Screwdriver, #2 Phillips Head Screwdriver and Hammer
- ✓ Caution: If using a power drill or power screwdriver for screwing, please be aware of to slow down and stop when screw is tight. Failure to do so may result in stripping the screw. (Assembly speed can be increased by using electric screwdriver)

Helpful Hints

PEOPLE NEEDED FOR ASSEMBLY: 1-2

- Open your item in the area you plan to keep it to avoid excessive heavy lifting.



- Identify, sort and count the parts before attempting assembly.

- Compression dowels are lightly tapped in with a hammer.

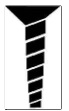

- Slides are labeled with an **R** (right) and **L** (left) for proper placement.



- Make sure to always face the point on the top of the Cam Lock towards the outer edge.

- If there is a back panel in the package, please install it to make sure your unit is complete and sturdy.



- Please fix all the screws provided for the back panel which can enhance product stability. If it is difficult to fix it when tightening, it can be fixed with the help of a hammer and then tightened.



- Do NOT use harsh chemicals or abrasive cleaners on this item.



- Never push, pull, or drag your furniture.

Board Identification

Not actual size

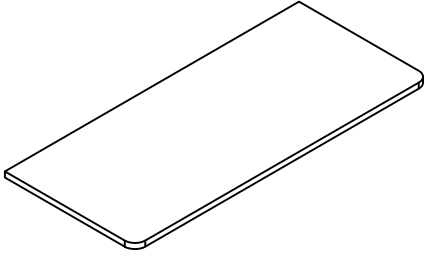

Ⓐ

Qty:1

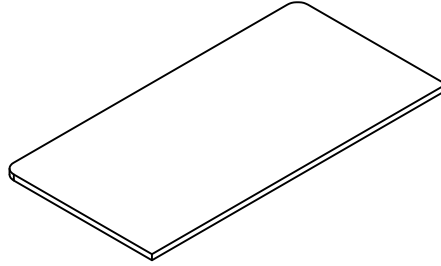

Ⓑ

Qty:1

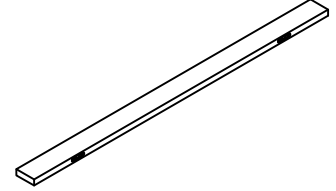

Ⓒ

Qty:1

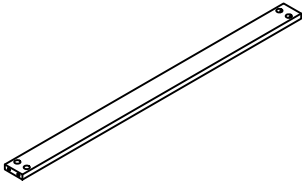

Ⓓ

Qty:1

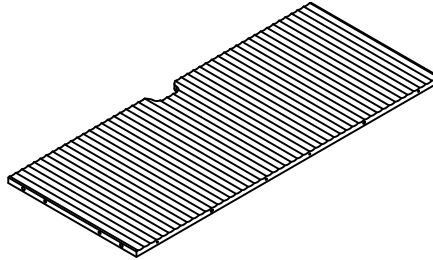

Ⓔ

Qty:2

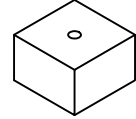

Ⓕ

Qty:1

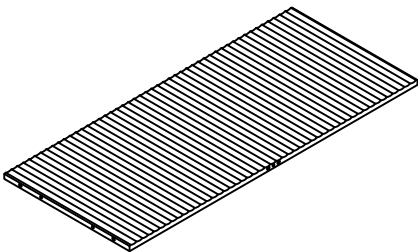

Ⓖ

Qty:1

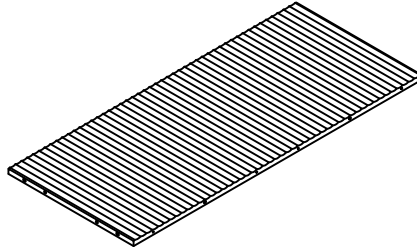

Ⓗ

Qty:1

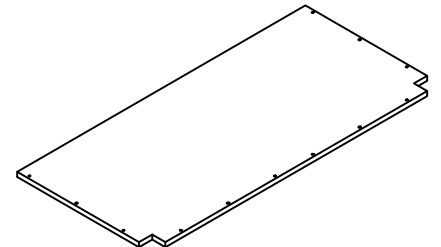

Ⓘ

Qty:1

Board Identification

Not actual size

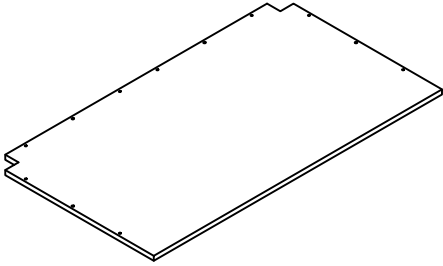

ⓐ
Qty:1

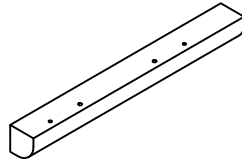

ⓑ
Qty:4

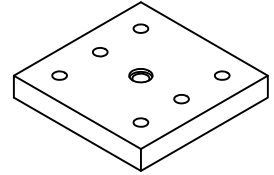

ⓒ
Qty:1

Part List

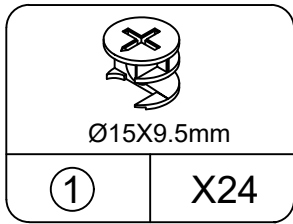

CAM LOCK
spare:2

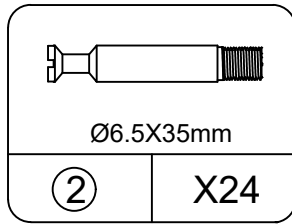

CAM BOLT
spare:2

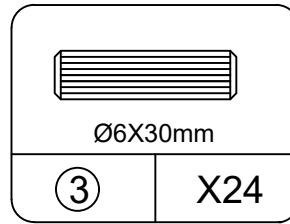

WOOD DOWEL
spare:2

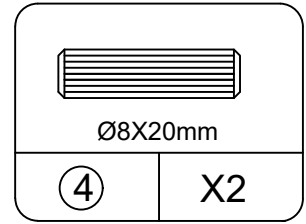

WOOD DOWEL
spare:1

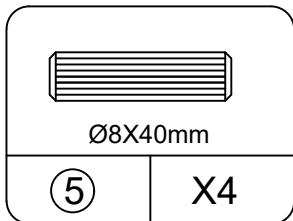

WOOD DOWEL
spare:1

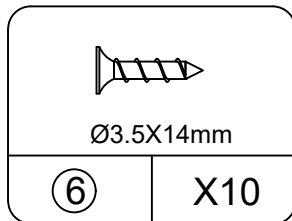

SCREW
spare:2

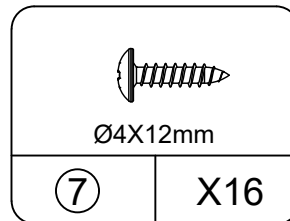

SCREW
spare:2

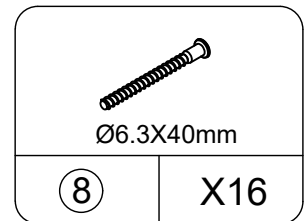

SCREW
spare:2

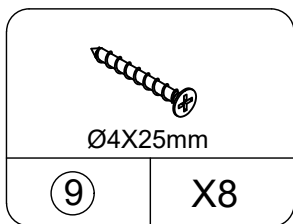

SCREW
spare:2

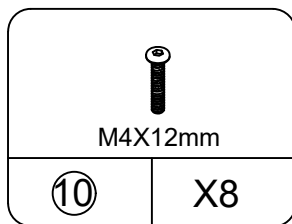

SCREW
spare:2

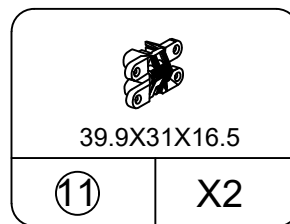

HINGE

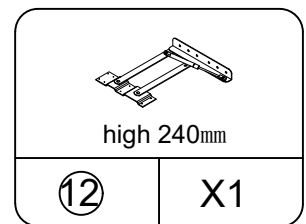

HYDRAULIC ROD LEFT

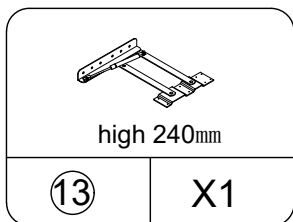

RIGHT HYDRAULIC ROD

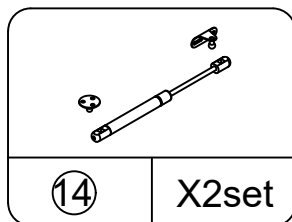

HYDRAULIC ROD

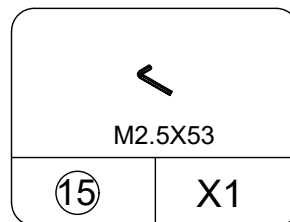

HEX KEY

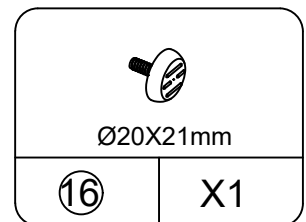

ADJUSTABLE FOOT

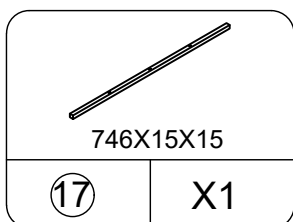

IRON PIPE

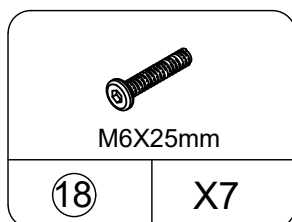

SCREW
spare:1

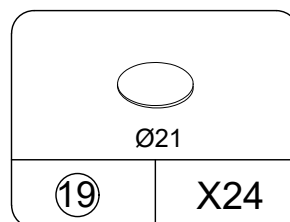

STICKER;DECAL
spare:2

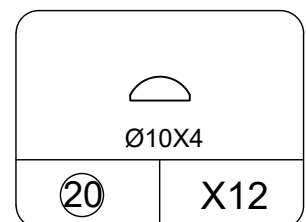

TRANSPARENT GLUE PELLETS
spare:2

Part List

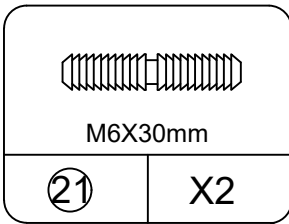

DOUBLE-HEADED TOOTH
spare:1

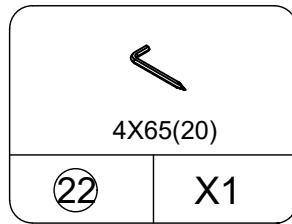

COMBINATION WRENCH

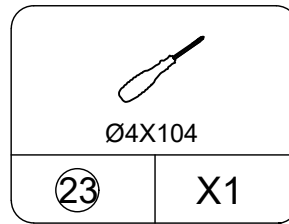

SCREWDRIVER

Cam Lock Fastening System

Insert the cam bolt into the hole first, then insert the cam lock and lock it.

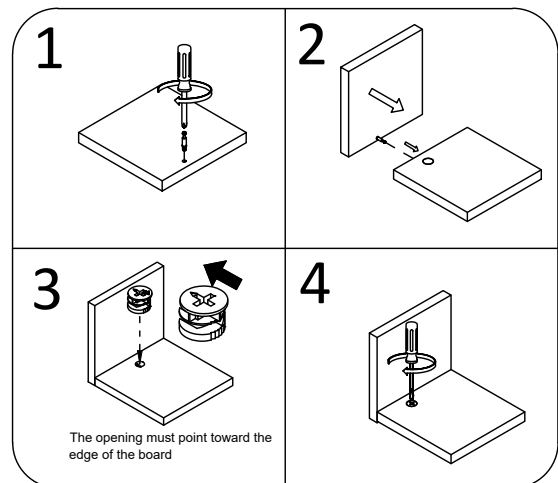

Board Identification

Not actual size

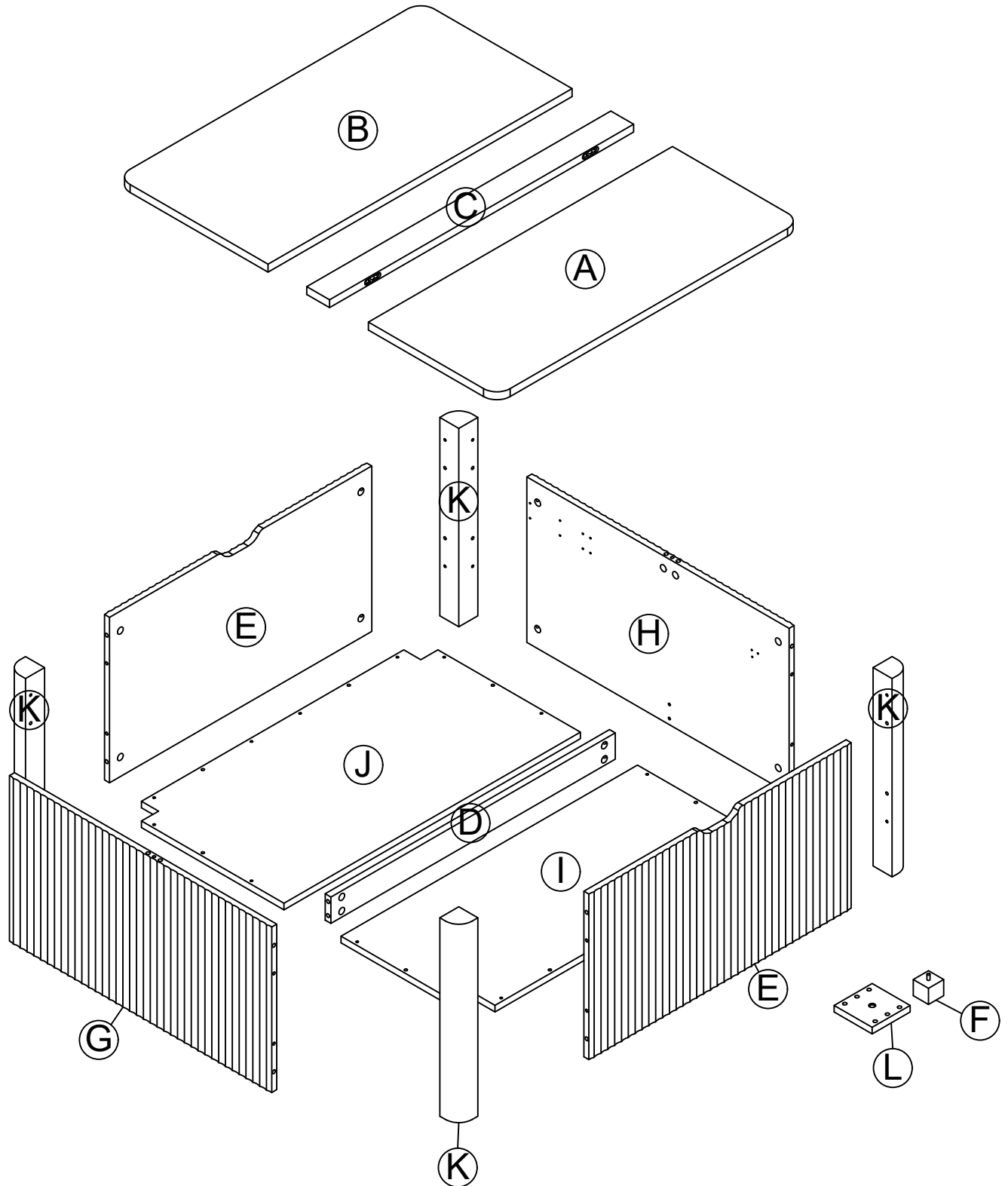

STEP 1

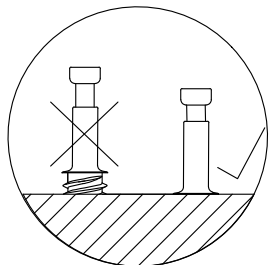
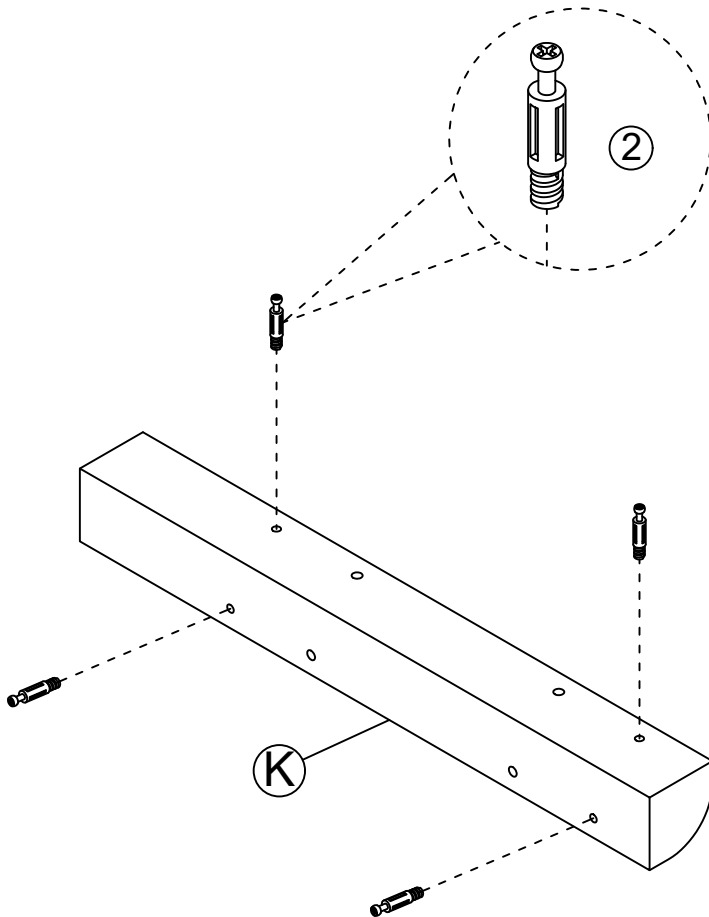
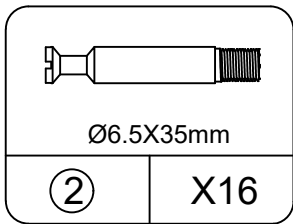
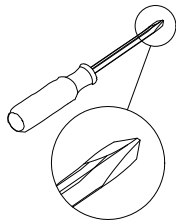

X4

STEP 2

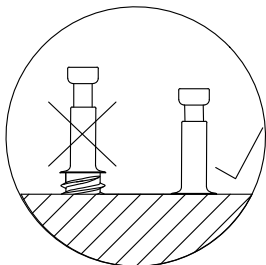
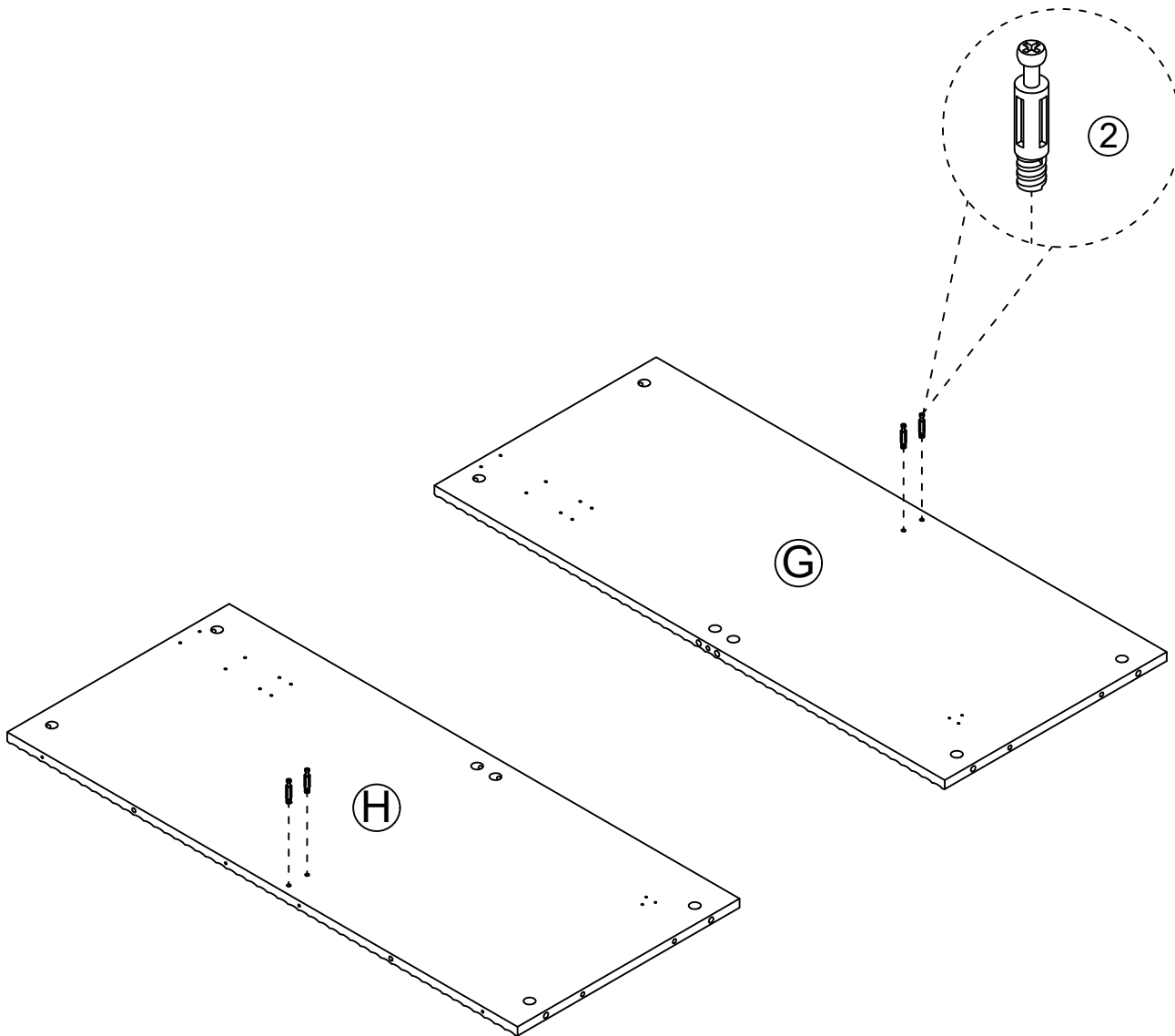
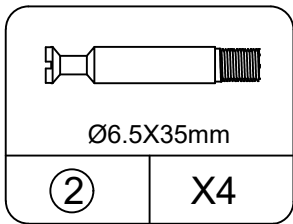
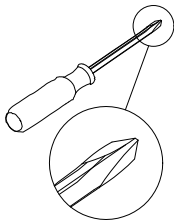

STEP3

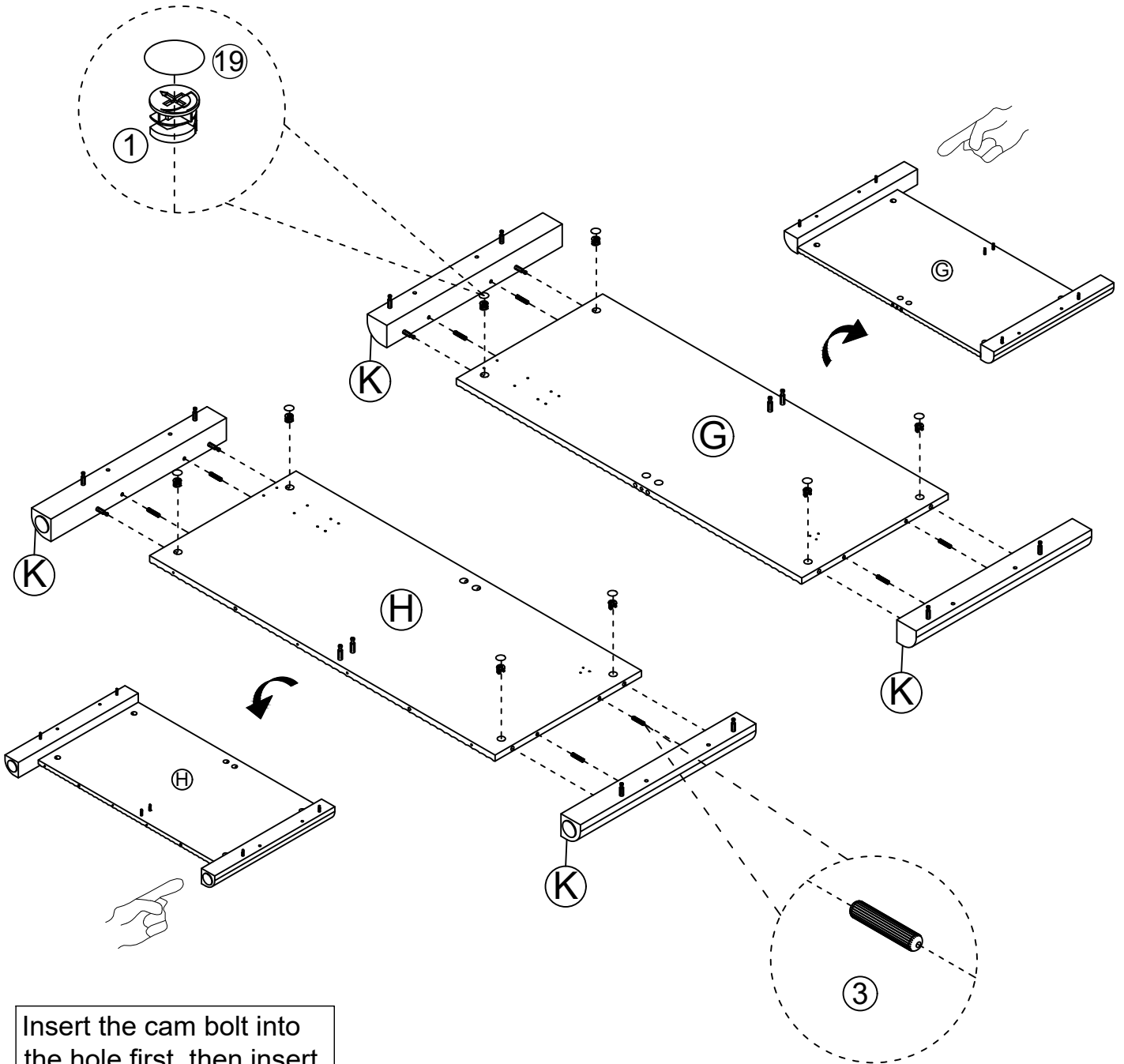
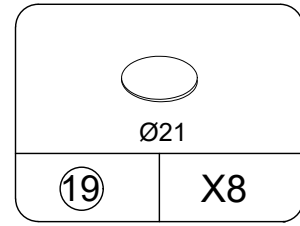
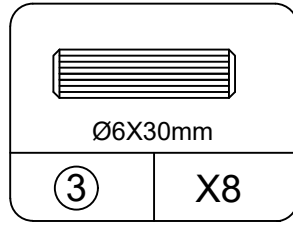
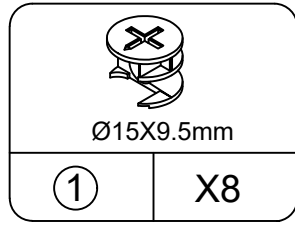
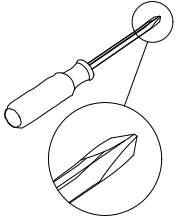

Insert the cam bolt into the hole first, then insert the cam lock and lock it.

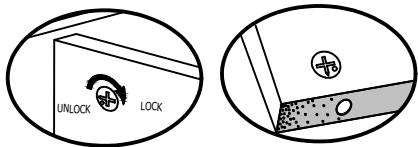

Proper orientation of CAM LOCK

STEP 4

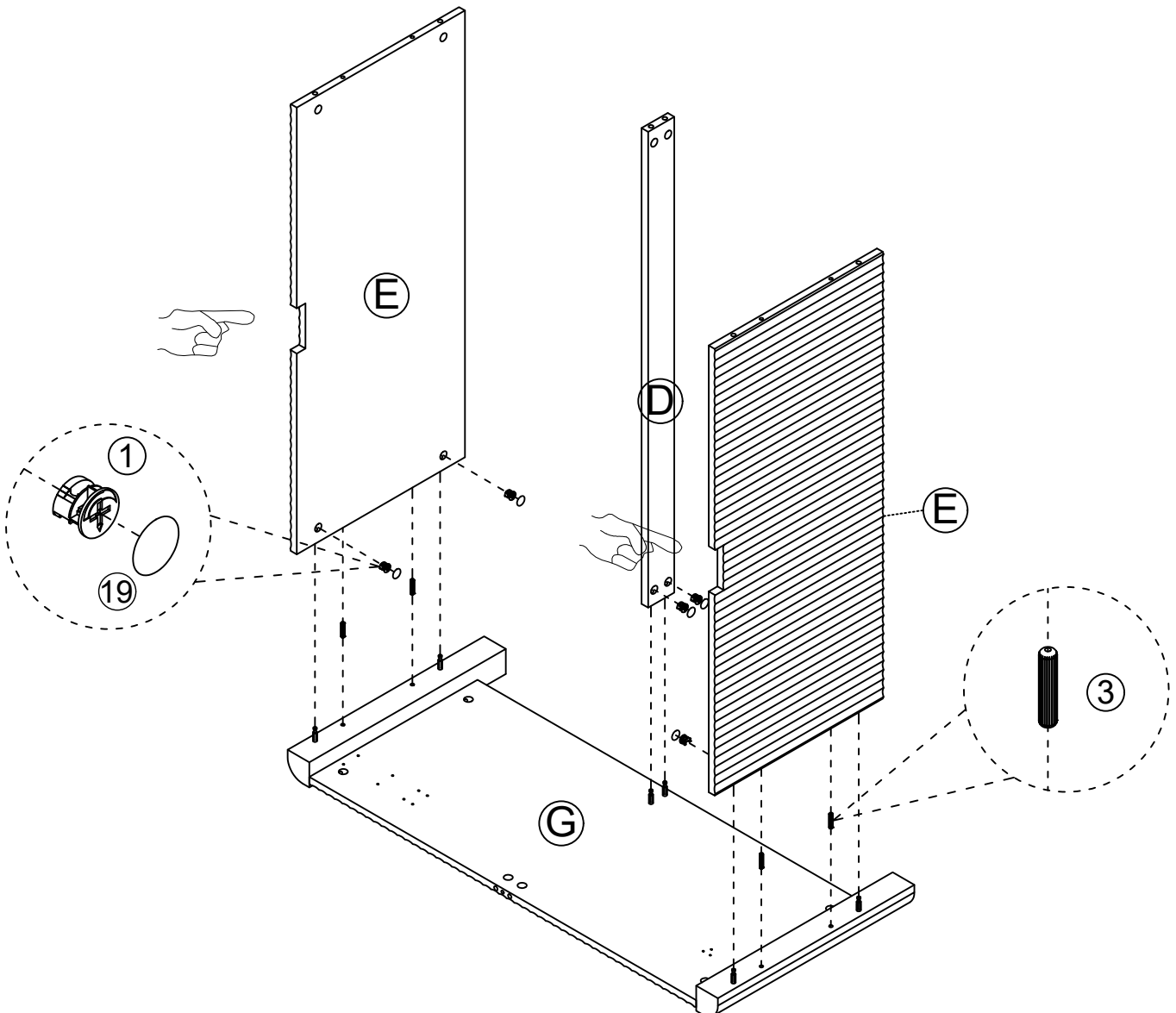
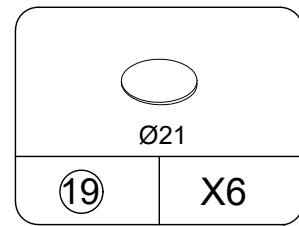
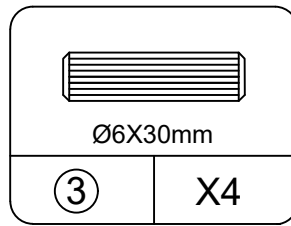
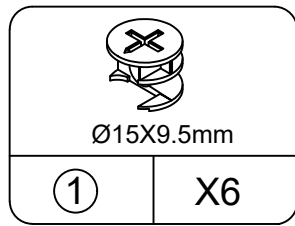
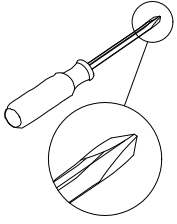

Insert the cam bolt into the hole first, then insert the cam lock and lock it.

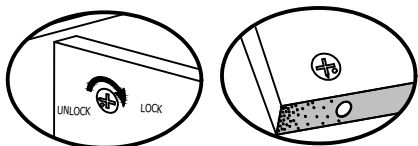

Proper orientation of CAM LOCK

STEP5

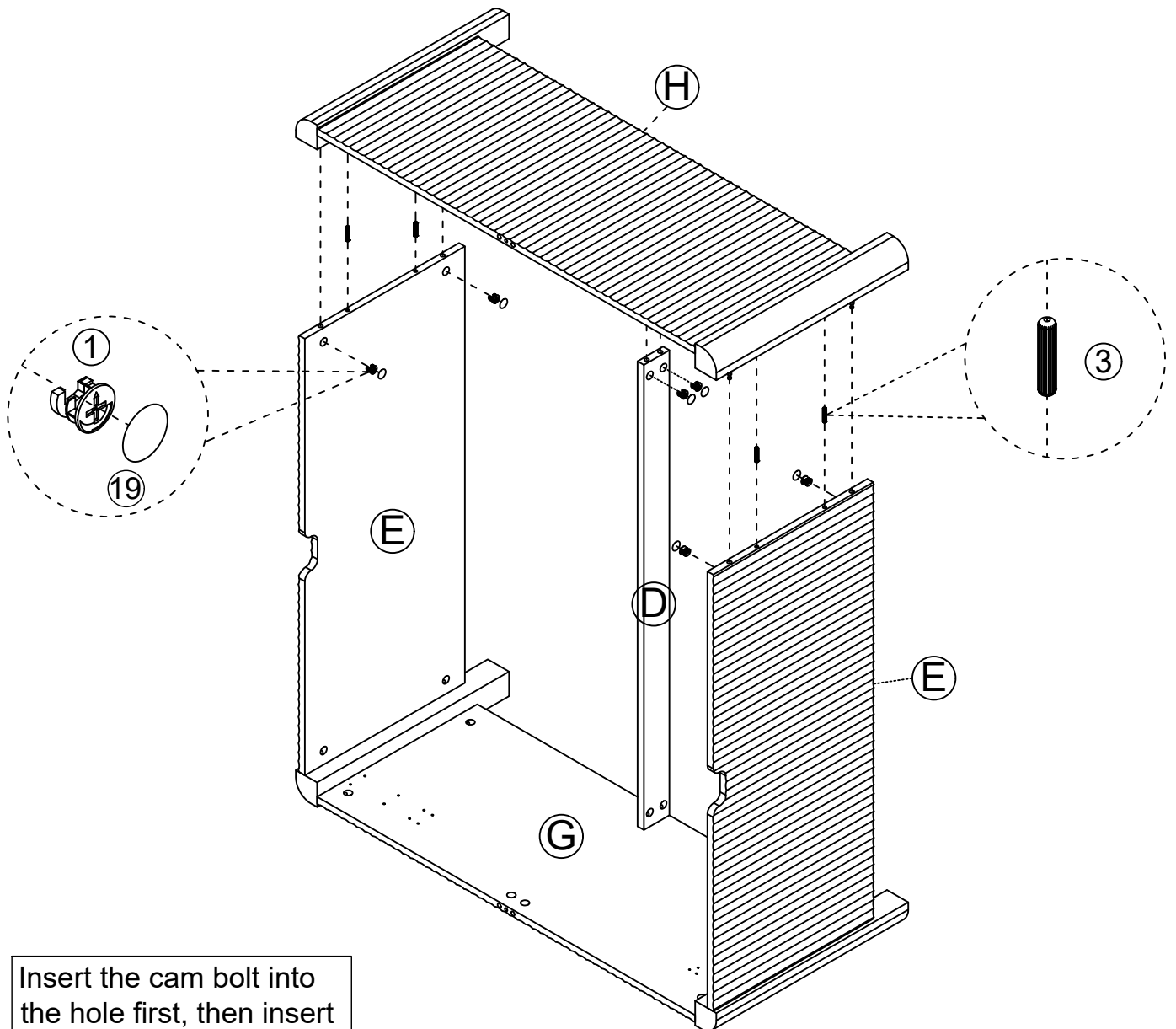
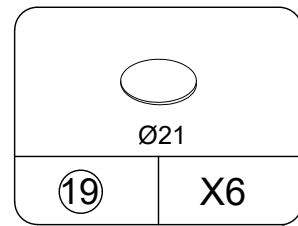
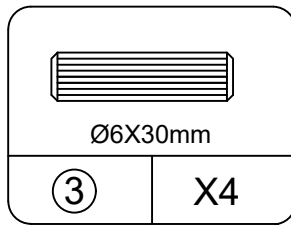
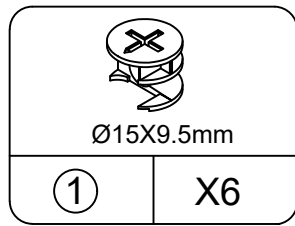
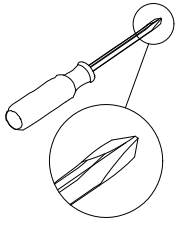

Insert the cam bolt into the hole first, then insert the cam lock and lock it.

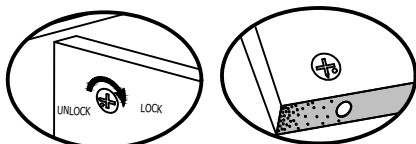

Proper orientation of CAM LOCK

STEP 6

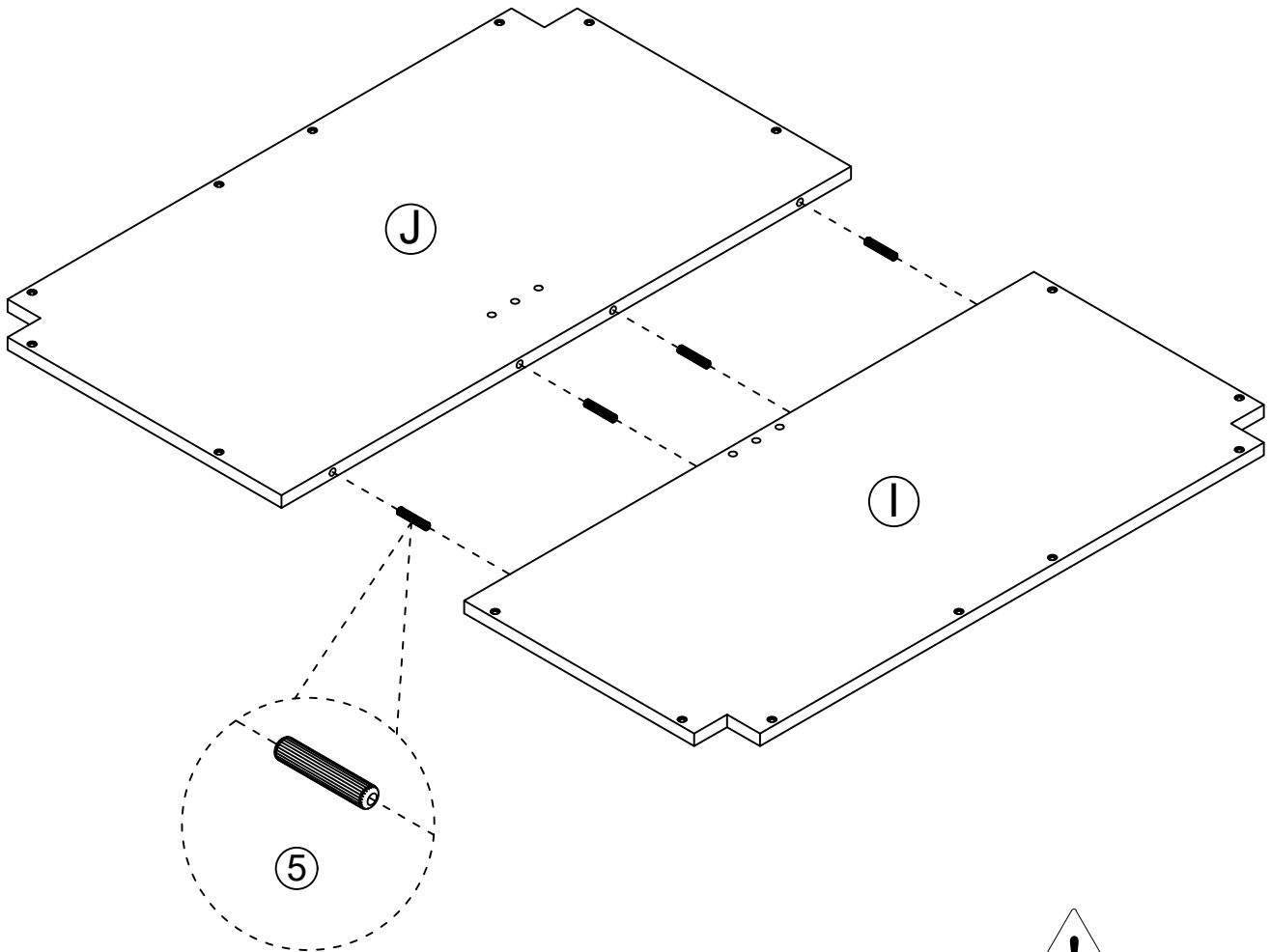
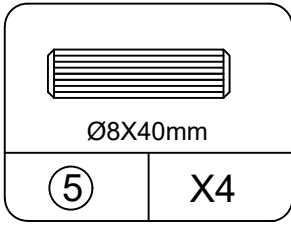

The front bottom plate I is short and the rear bottom plate J is long.

STEP 7

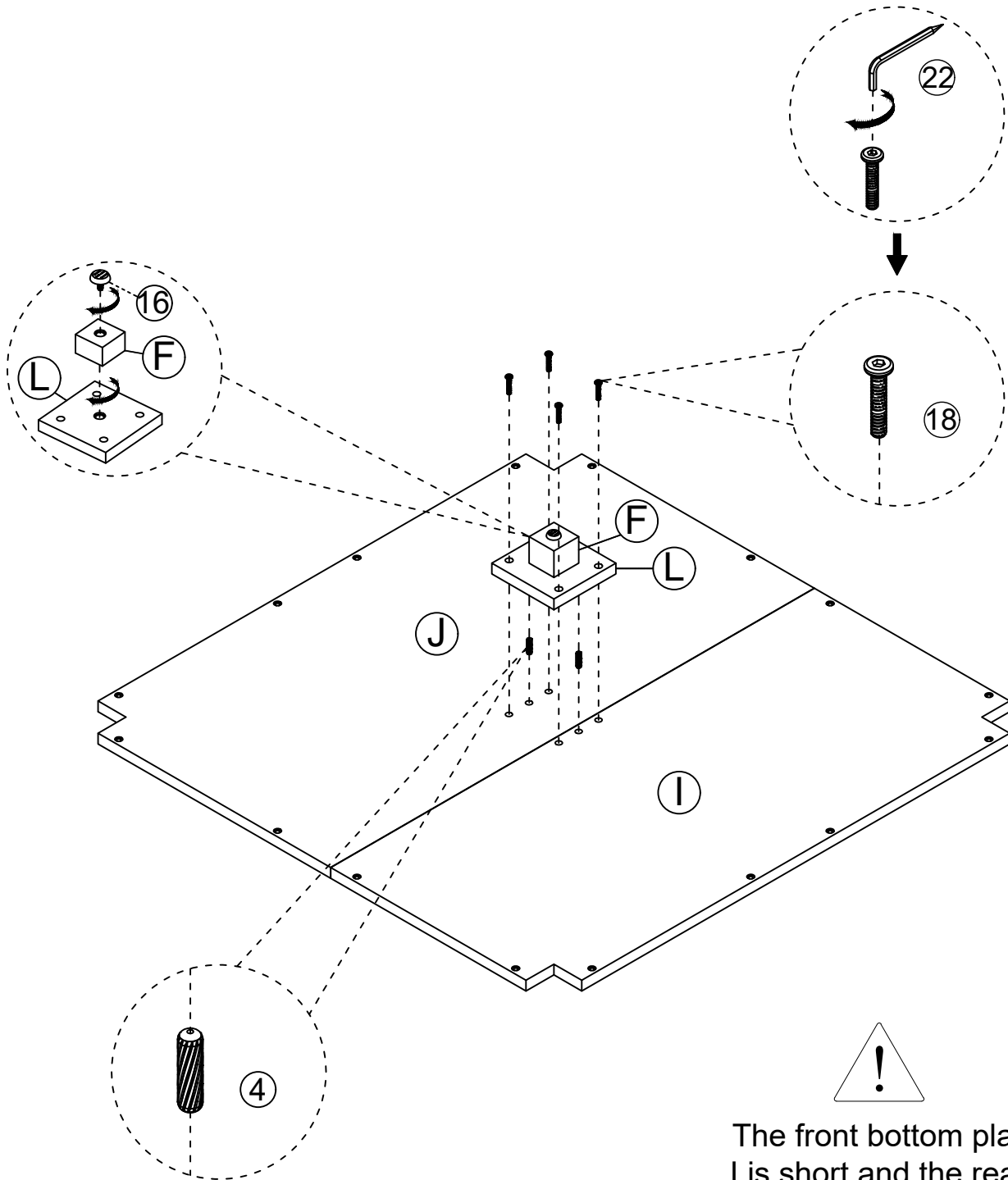
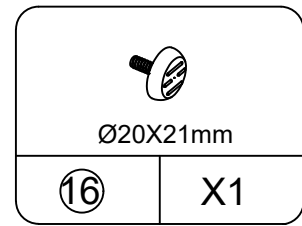
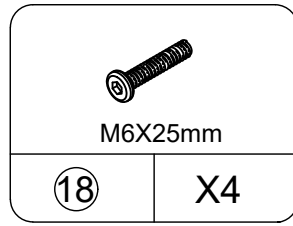
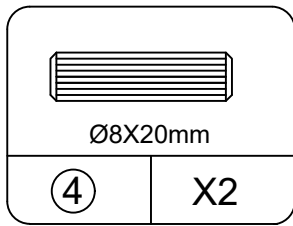

The front bottom plate I is short and the rear bottom plate J is long.

STEP 8

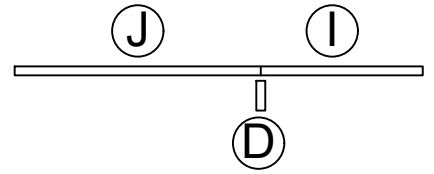
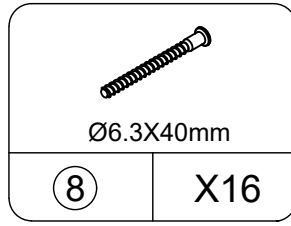
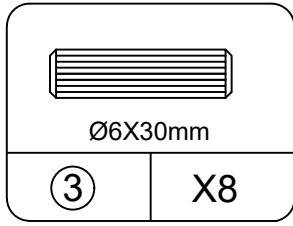
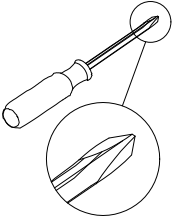

One more person is needed to help, otherwise it is easy to disperse.

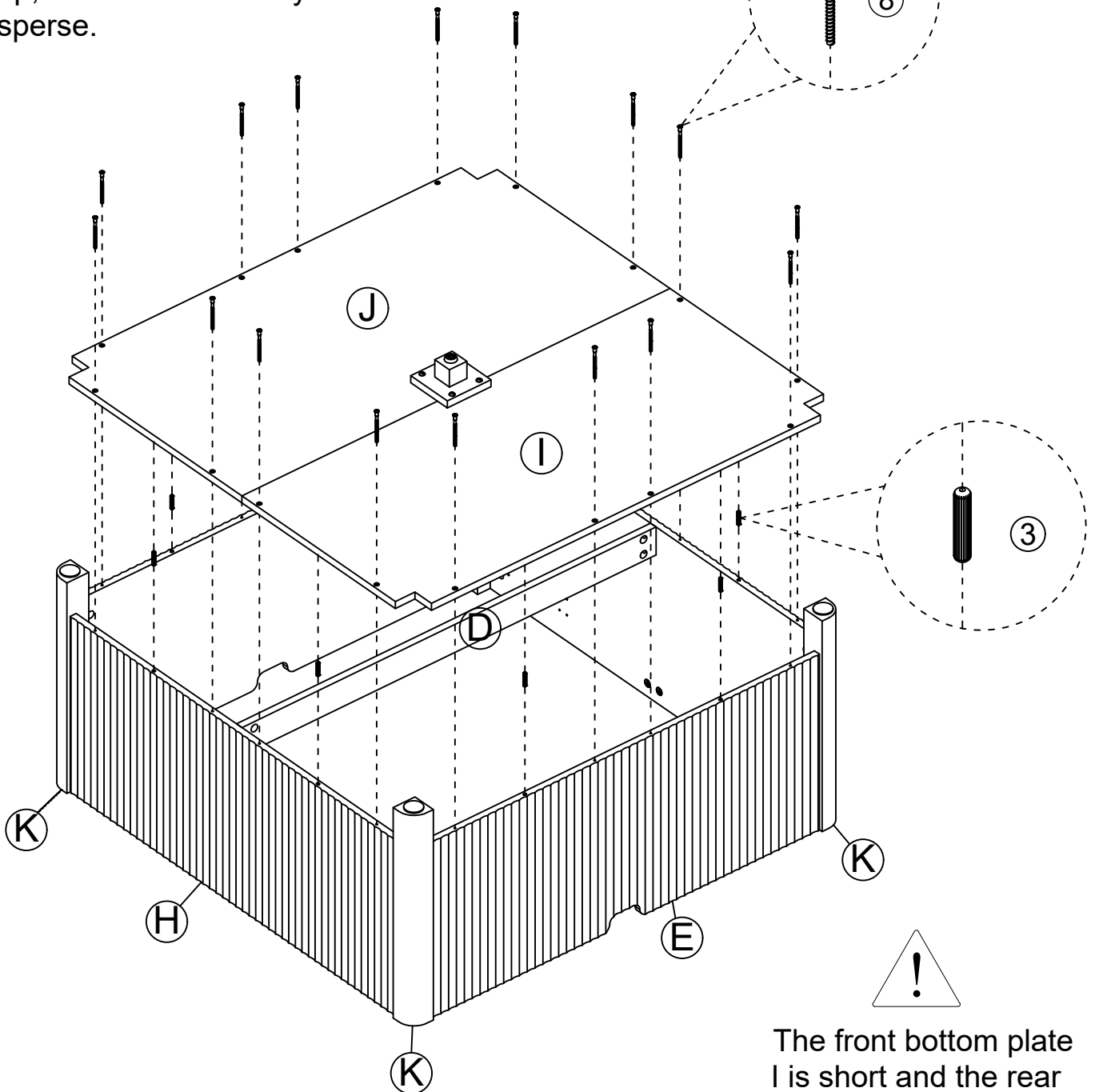

The front bottom plate I is short and the rear bottom plate J is long.

STEP 9

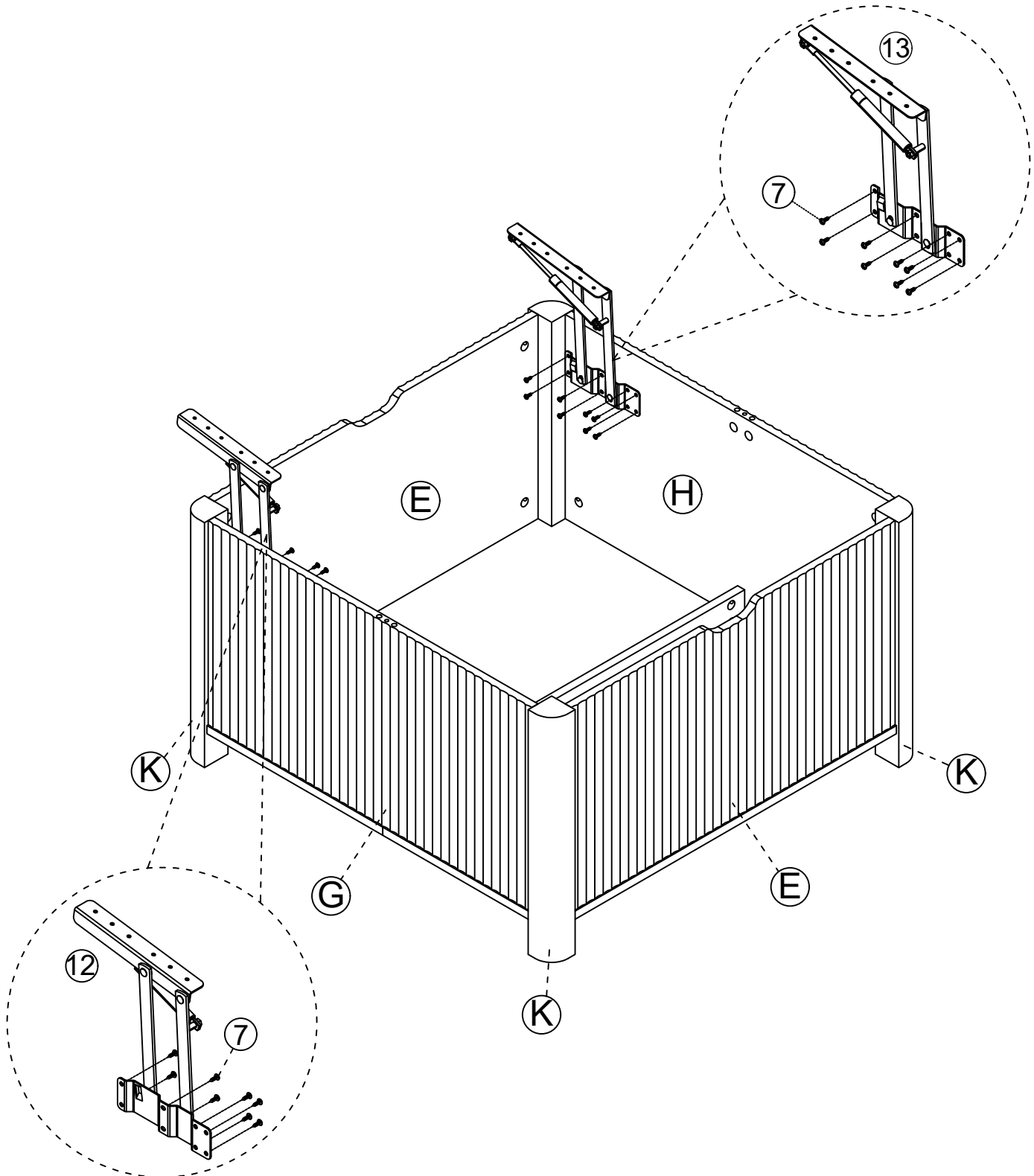
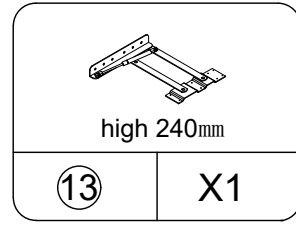
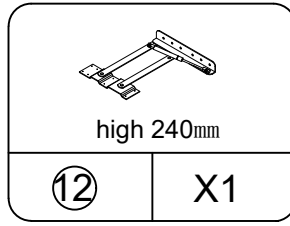
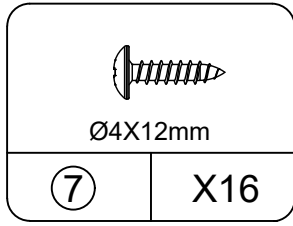
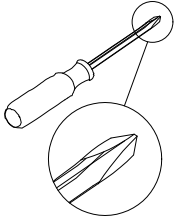

STEP10

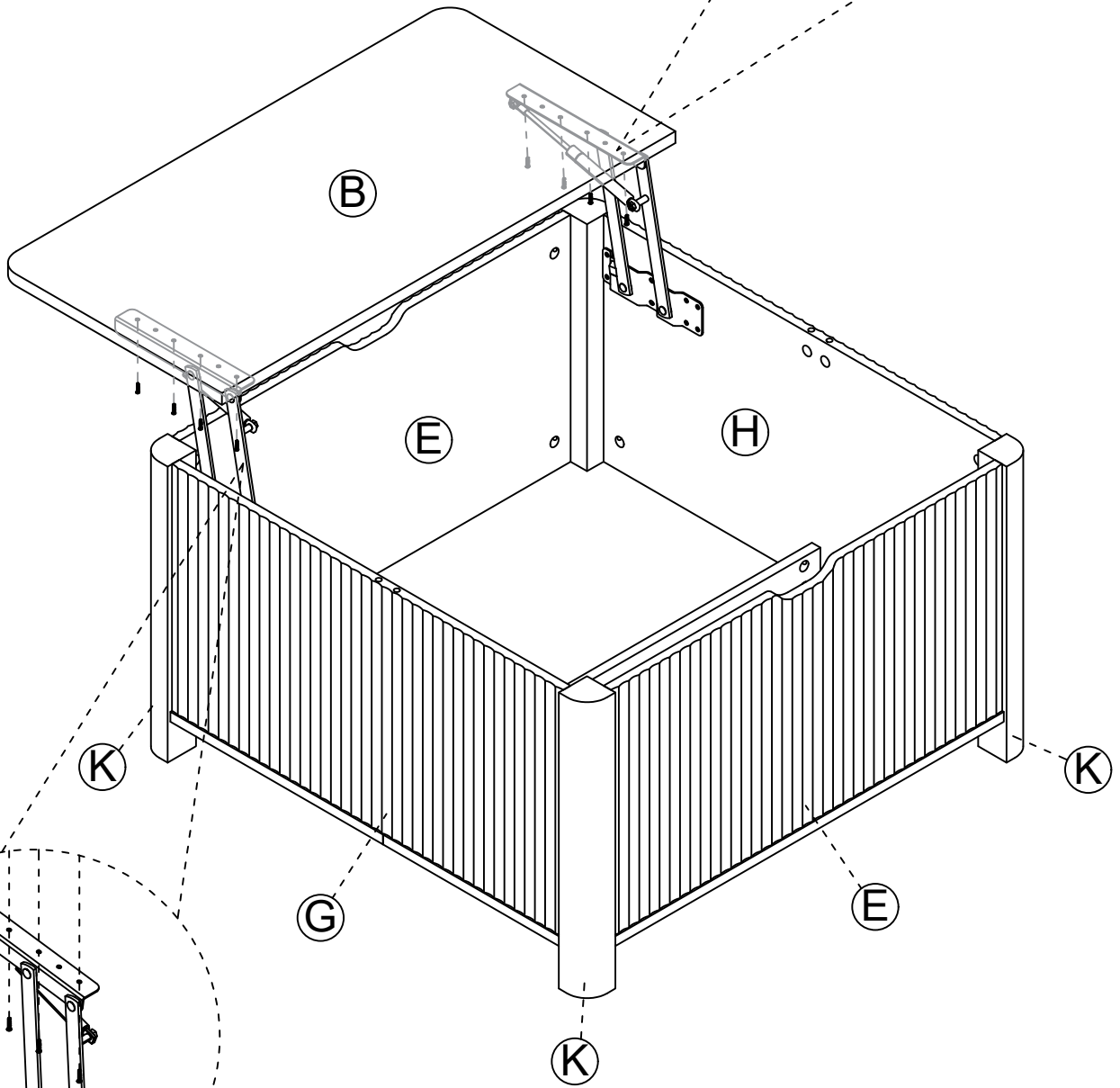
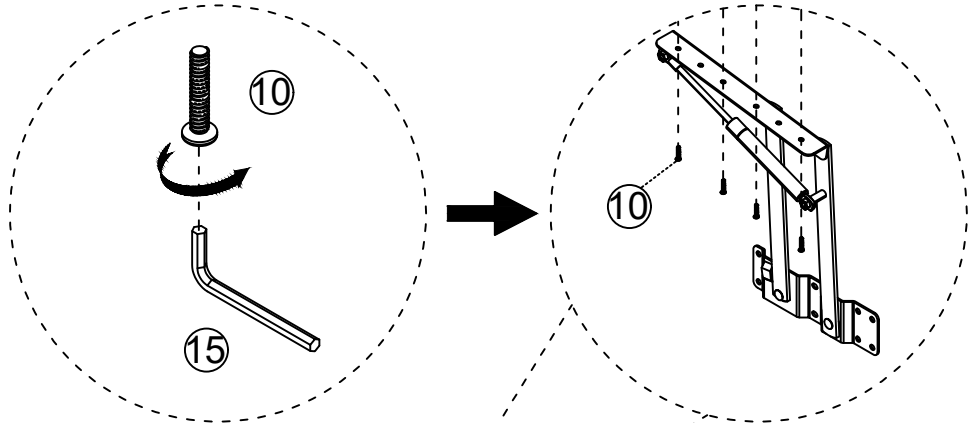
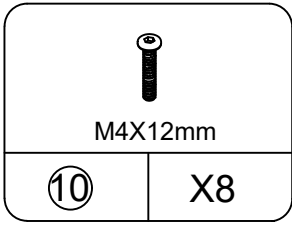

STEP11

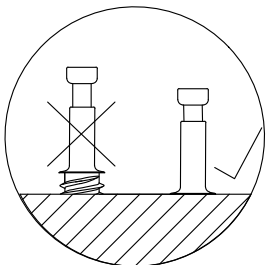
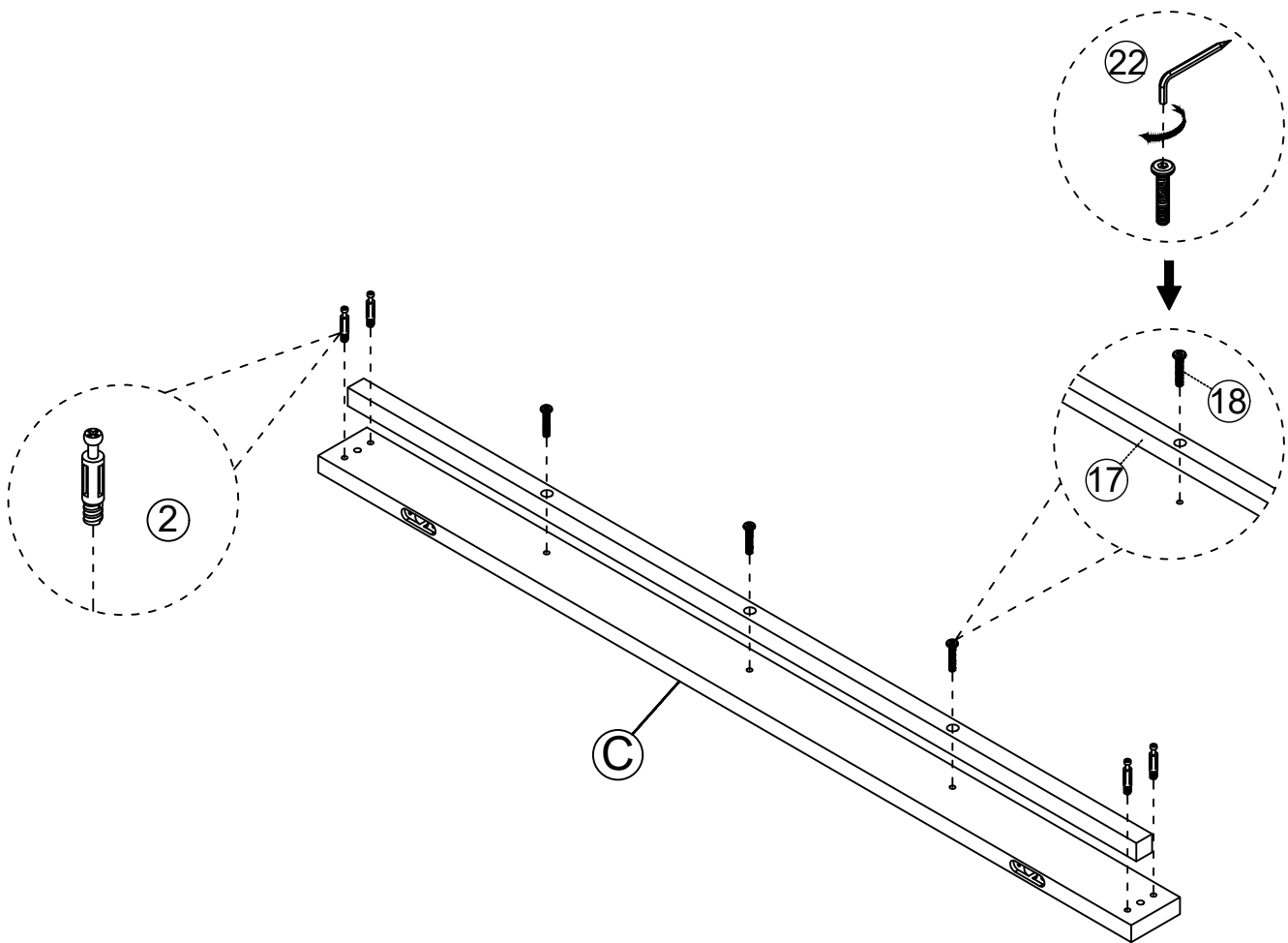
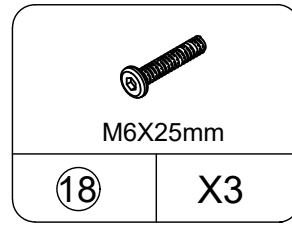
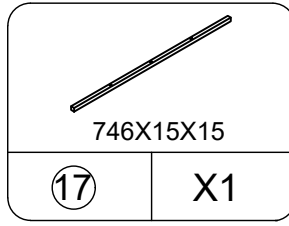
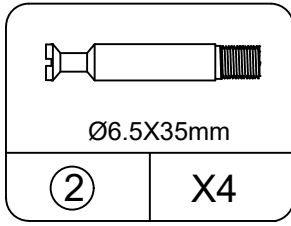
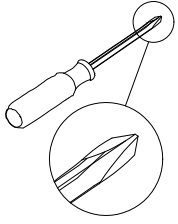

STEP12

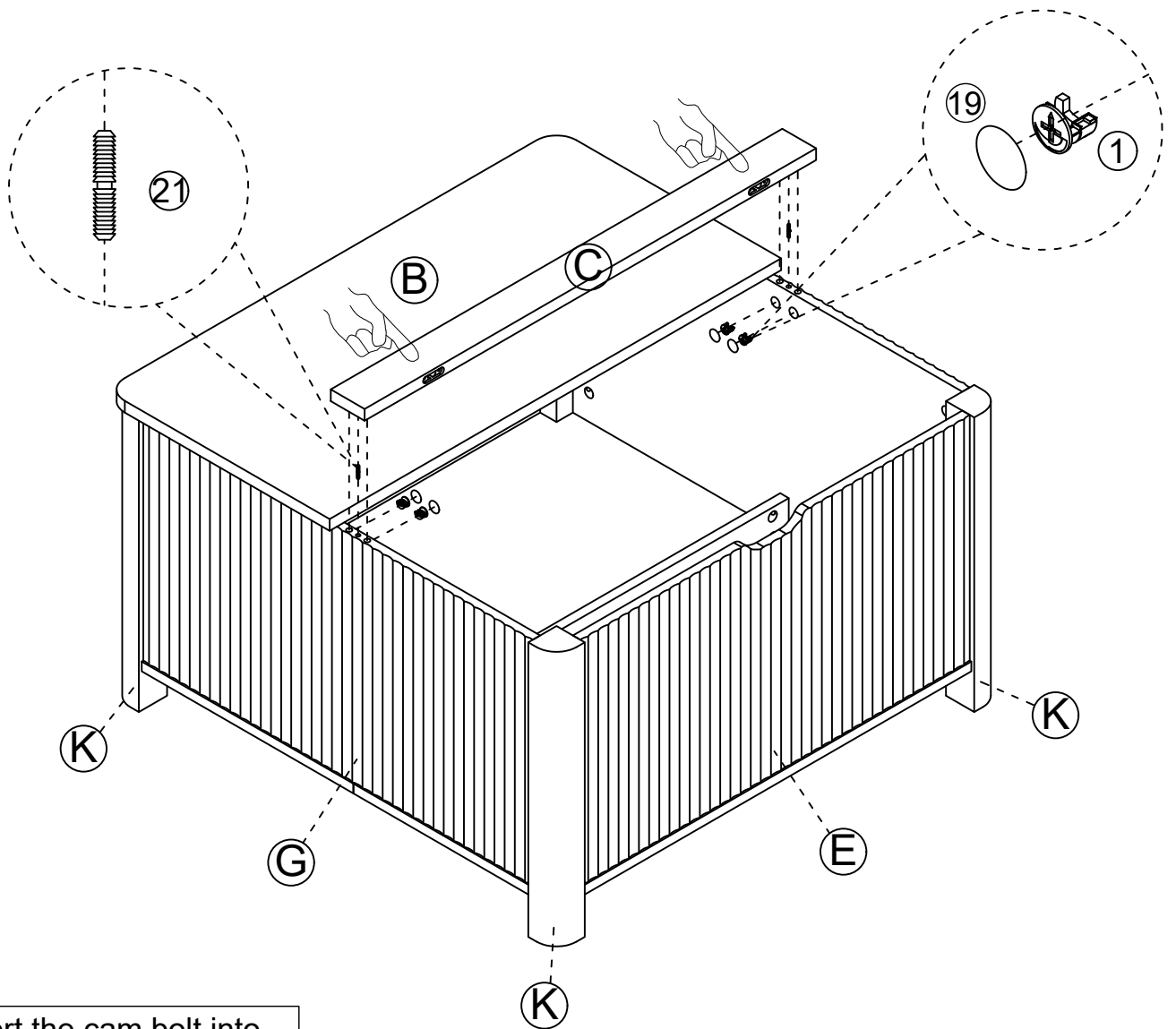
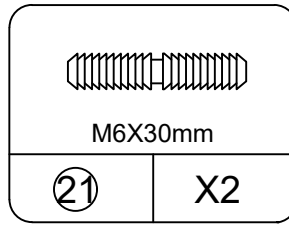
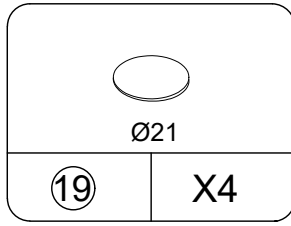
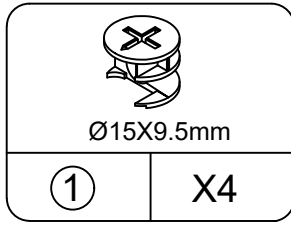
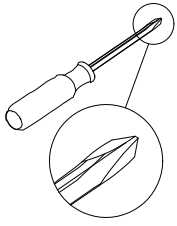

Insert the cam bolt into the hole first, then insert the cam lock and lock it.

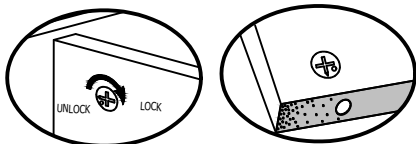

Proper orientation of CAM LOCK

STEP13

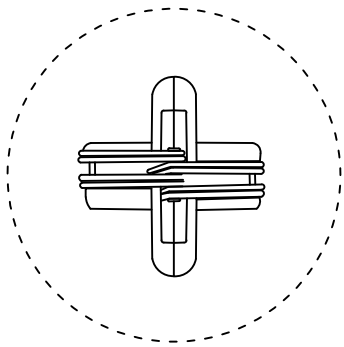
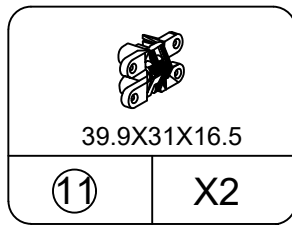
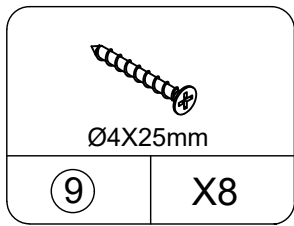
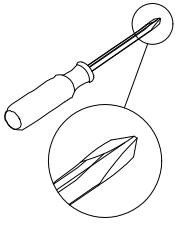

➔
Open

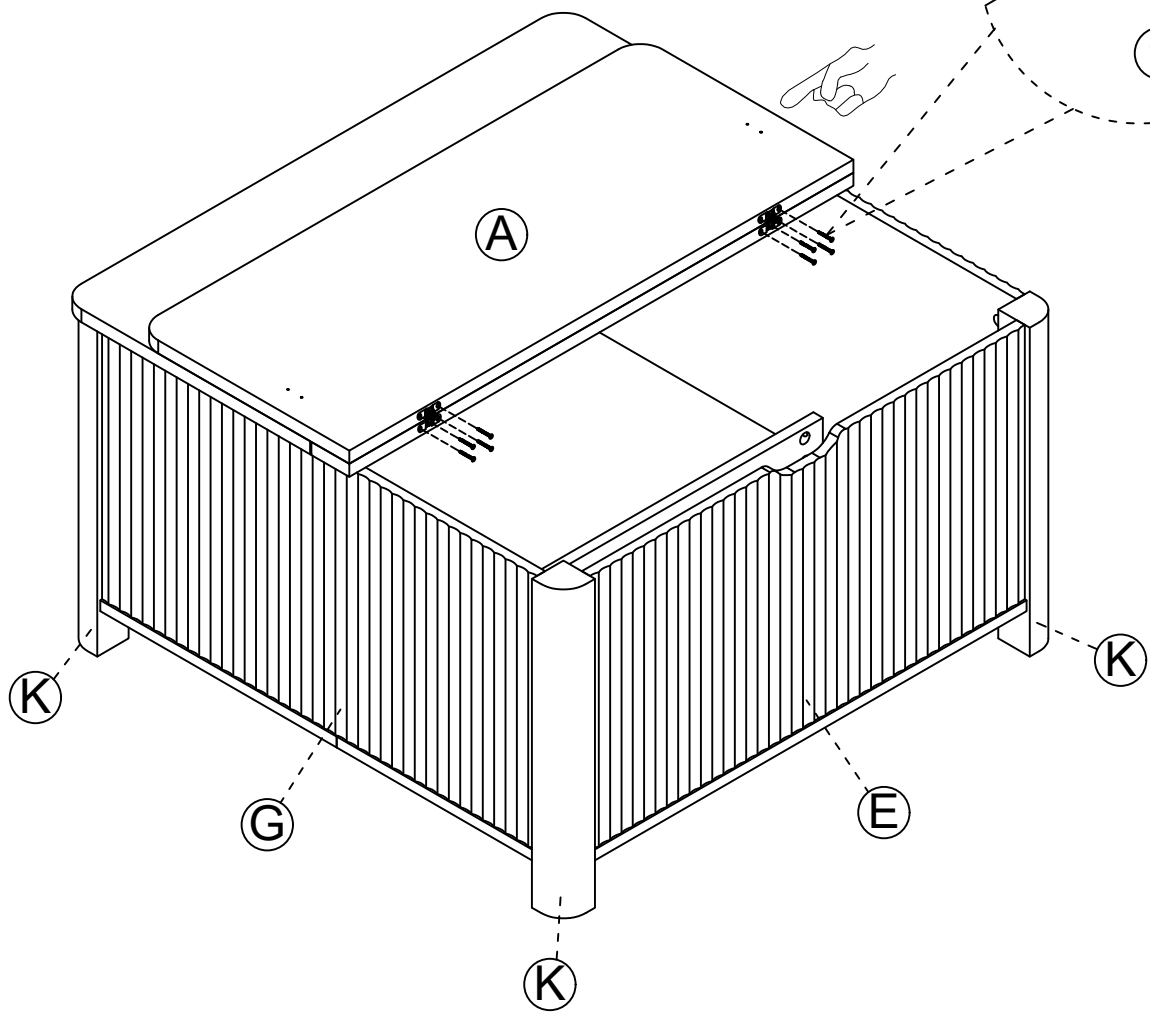
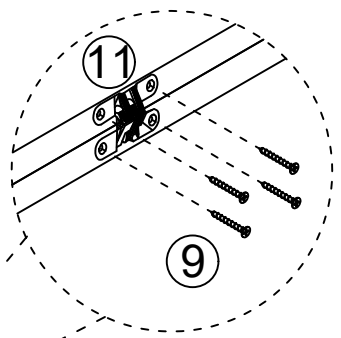
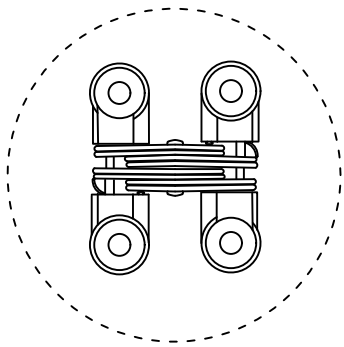

STEP14

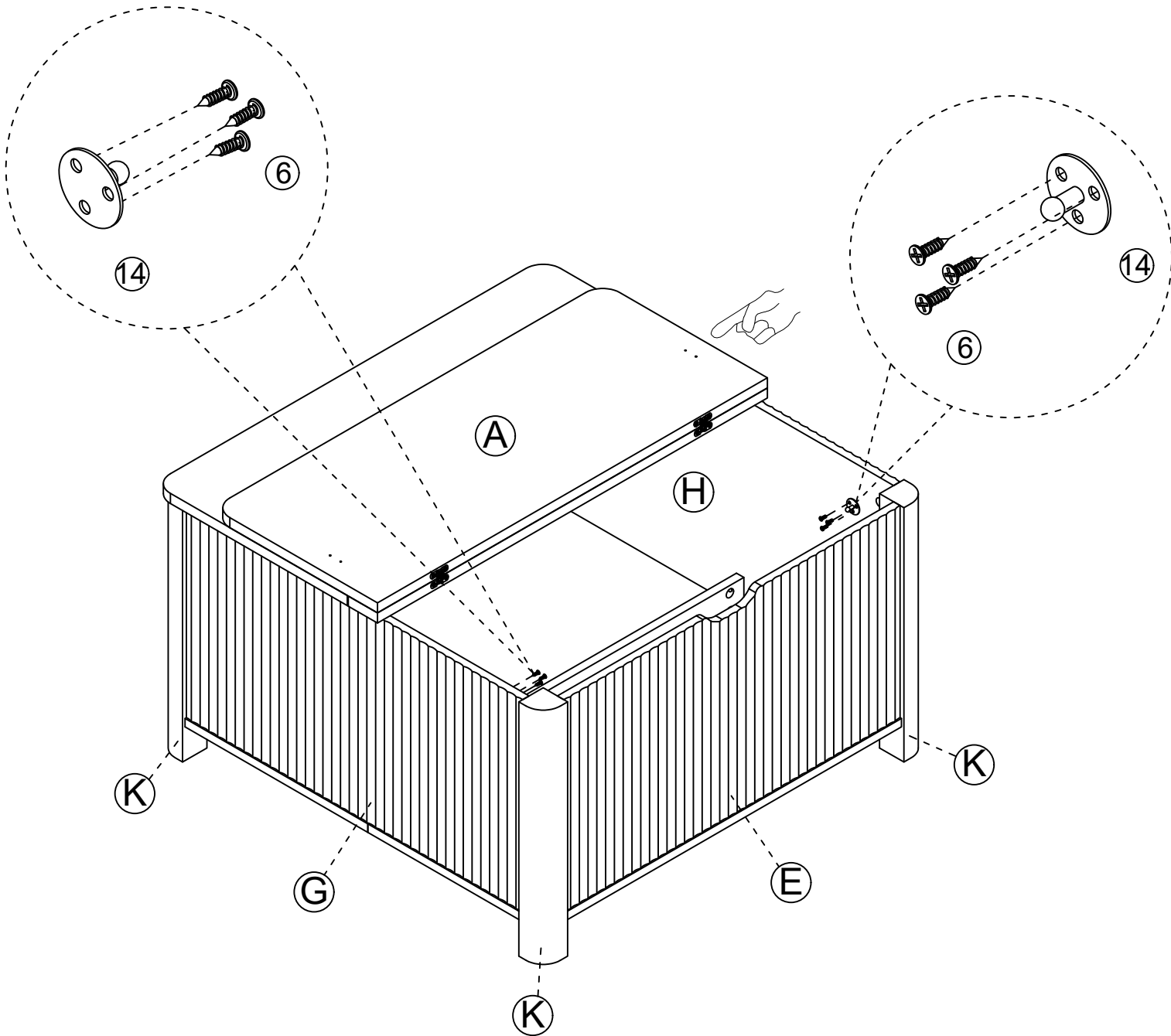
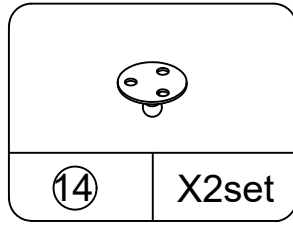
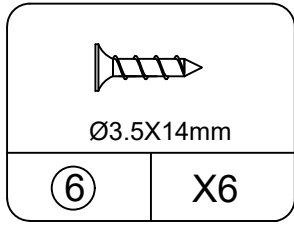
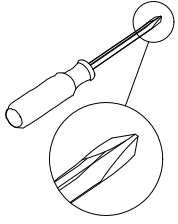

STEP15

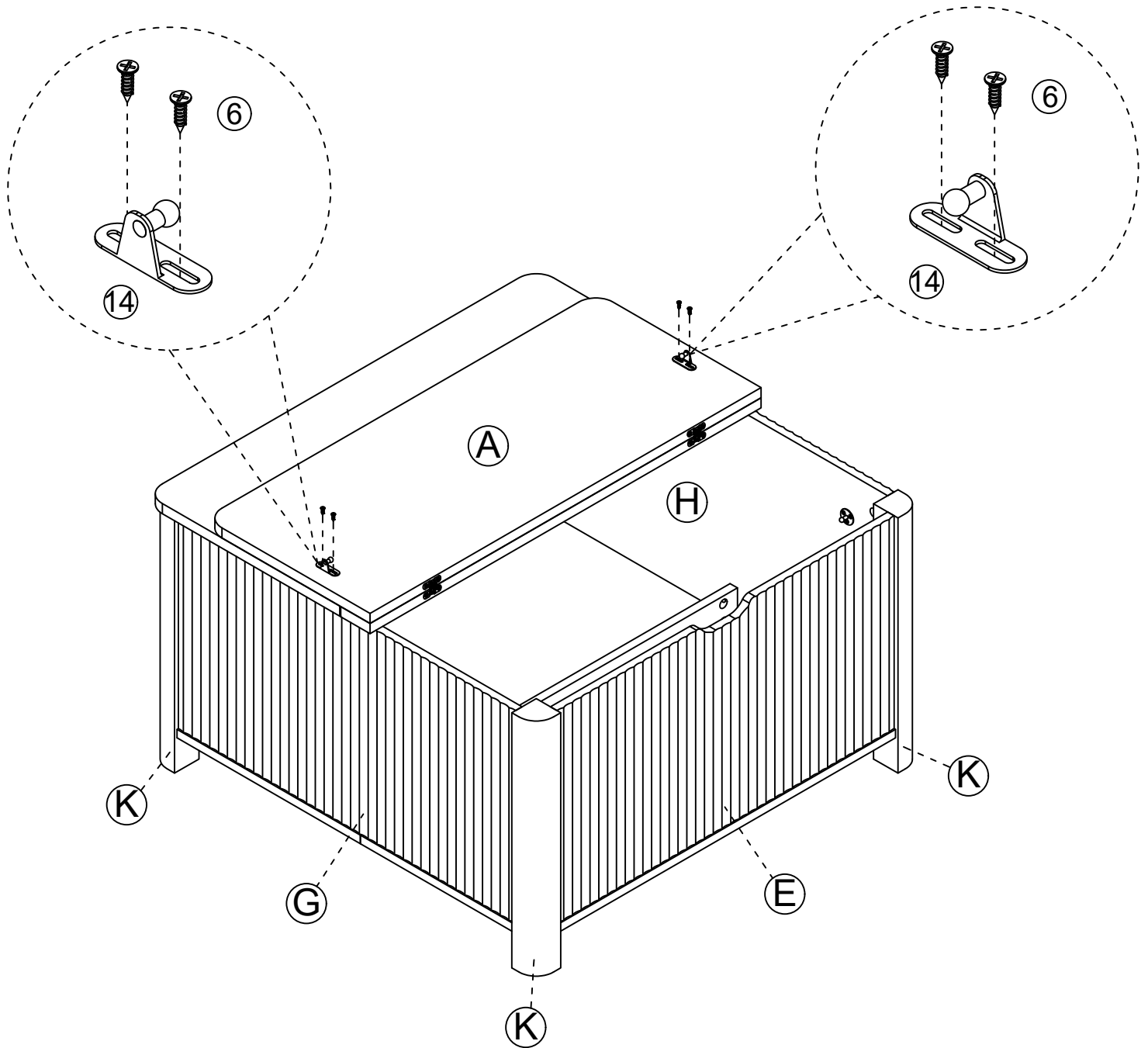
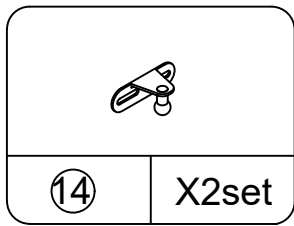
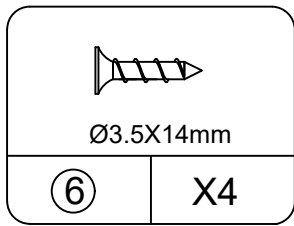
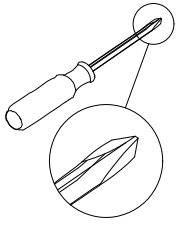

STEP16

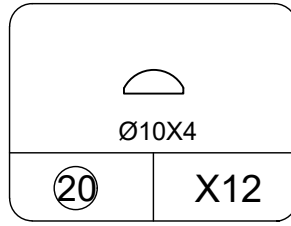
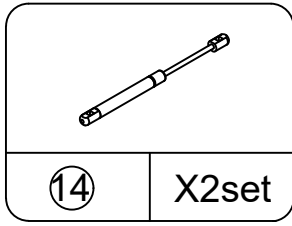
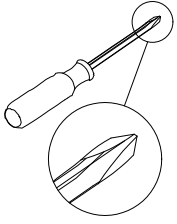

The thin end of the piston rod is at the top, the thick end at the bottom.

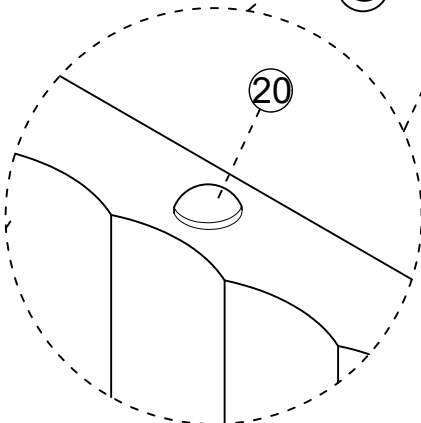
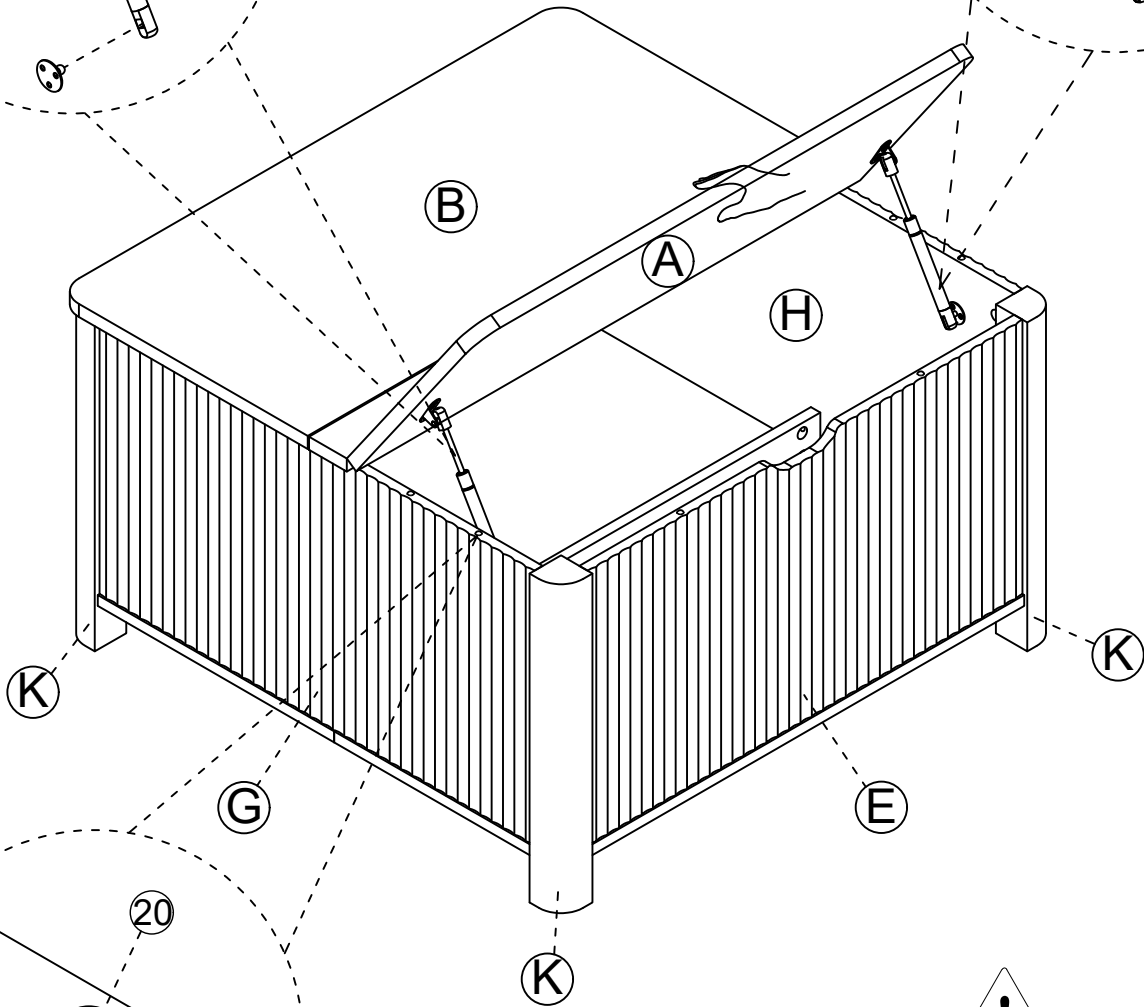
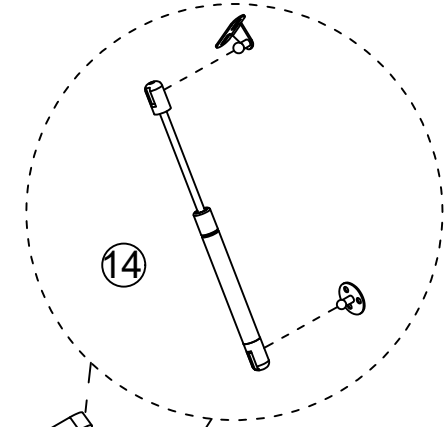
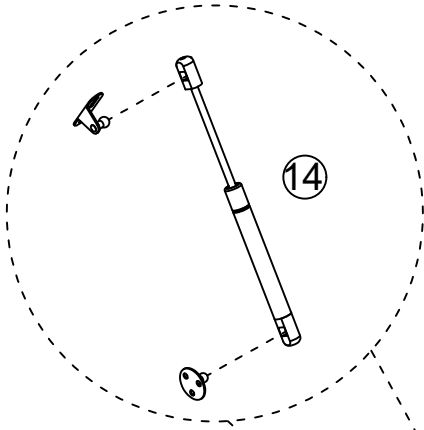

Transparent glue particles: front and back vertical plates each two, left and right vertical plates each four.

ADJUSTMENT INSTRUCTIONS

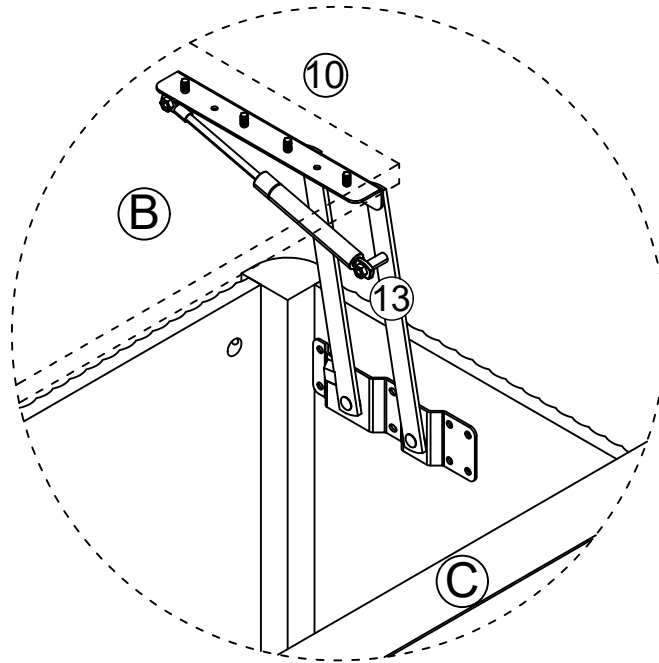

You can close the lifting bracket 13 after use the screw 10 assembling the lifting bracket 13 to the board B .

If you are not satisfied with the gap between board B and board C, you can adjust the gap by following the steps below:

1. Please loosen the screw 10 which on the lifting bracket 13.
2. After the screw is loose, if the panel gap is small, pull one side outwards, if the gap is large, push one side inwards
3. Hold the product firmly in place by hand, then tighten the screw 10 .