

ASSEMBLY  
INSTRUCTIONS

INSTRUCTIONS  
D'ASSEMBLAGE

INSTRUCCIONES DE  
ENSAMBLAJE

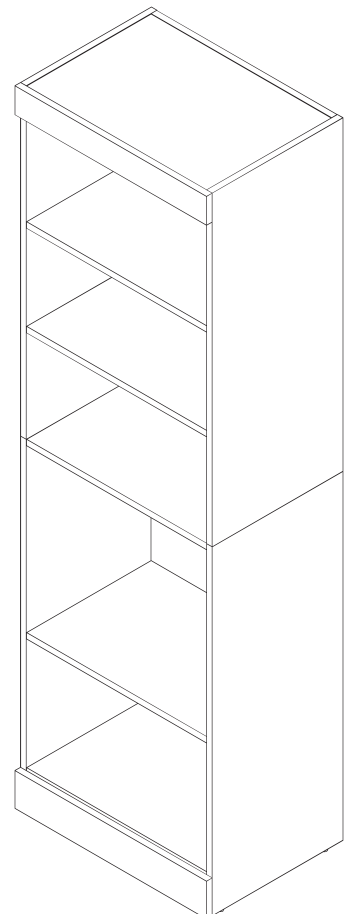

# Maintenance Tips

Conseils d'entretien  
Consejos de mantenimiento



**Never leave damp clothes, liquids or damp cloths on the furniture.  
If a liquid has spilled on the furniture, clean the liquid up immediately.**

Ne laissez jamais de liquide ni de vêtements ou de linge humides sur le meuble.  
Si un liquide est renversé sur le meuble, épongez-le immédiatement.

*Nunca deje líquidos o un trapos húmedos sobre su mueble.  
Si se derrama un líquido sobre la superficie del mueble, límpielo inmediatamente.*



**Clean the furniture with a damp cloth, then wipe dry.  
To avoid damaging the finish, do not use cleaning products on the furniture.**

Nettoyez votre meuble avec un linge légèrement humide, puis essuyez-le ensuite.  
N'utilisez pas de produits de nettoyage, car cela risque d'endommager le fini.

*Nunca utilice limpiadores químicos, ya que estos dañarán el acabado.  
Use solo un paño húmedo.*



**Do not put devices with plastic or rubber pads directly on your furniture.  
Instead, attach cloth or felt pads to your device.**

Évitez de déposer des appareils munis de patins en caoutchouc ou en plastique directement sur le meuble. Utilisez des protecteurs en tissu ou en feutre sous les appareils.

*Evite apoyar aparatos con bases de plástico o de goma directamente sobre su mueble.  
Utilize un protector de tela o de fieltro.*



**To avoid dulling the finish, do not place furniture in direct sunlight.**

Afin de préserver la belle apparence de votre meuble,  
évitez de l'exposer à la lumière directe du soleil.







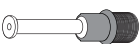

*Para prevenir empañamiento, no exponga el mueble directamente a la luz solar solar.*

# Parts & Hardwares • Pièces et quincailleries • Piezas Y Quincallas

## Parts • Pièces • Piezas

Code • Código	Qty • Qté • Cant.	Code • Código	Qty • Qté • Cant.	Code • Código	Qty • Qté • Cant.	Code • Código	Qty • Qté • Cant.
30	1	33	1	42	3	80	1
31	1	40	1	70	1	84	1
32	1	41	2	71	1		

## Hardwares • Quincailleries • Quincallas

Code • Código	Qty • Qté • Cant.	Code • Código	Qty • Qté • Cant.	Code • Código	Qty • Qté • Cant.	Code • Código	Qty • Qté • Cant.
2004-MM4X35CSX2 	2	H-36 	30	H220025 	2	TI-118 	12
CA-99  5/8 in/po (15 mm)	8	H126396 	12	PA-844  1 in/po (25 mm)	4	TI-552 	2
H-03 	30						

## Real Size • Tailles réelles • Tamaño real

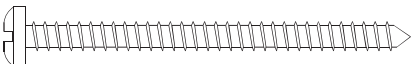
Code • Código	Qty • Qté • Cant.
VR-215  2 in/po (51 mm)	2

### Important Notice • Note importante • Nota importante

Group together all the hardware required for each step as the construction of your piece of furniture is progressing.

Regroupez toutes les quincailleries requises pour chaque étape de façon à vous assurer de tout installer au bon moment.

Reúna todas las quincallas necesarias para cada una de las etapas de montaje, para asegurar una correcta instalación en el momento adecuado.

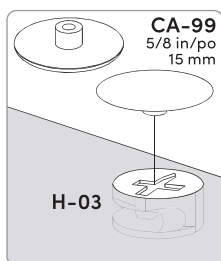

**CA-99**  
5/8 in/po  
15 mm

When you have completed the assembly of your new furniture, install plastic caps.

Lorsque vous avez complété l'assemblage de votre meuble, installez les capuchons de plastique.

Una vez que haya completado el ensamblaje del mueble, coloque los capuchones de plástico.

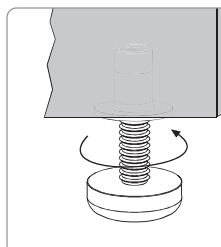

### PA-844

To level your furniture, use leg levelers.

Pour niveler votre meuble utilisez les pattes ajustables.

Para nivelar su mueble utilice las patas ajustables.

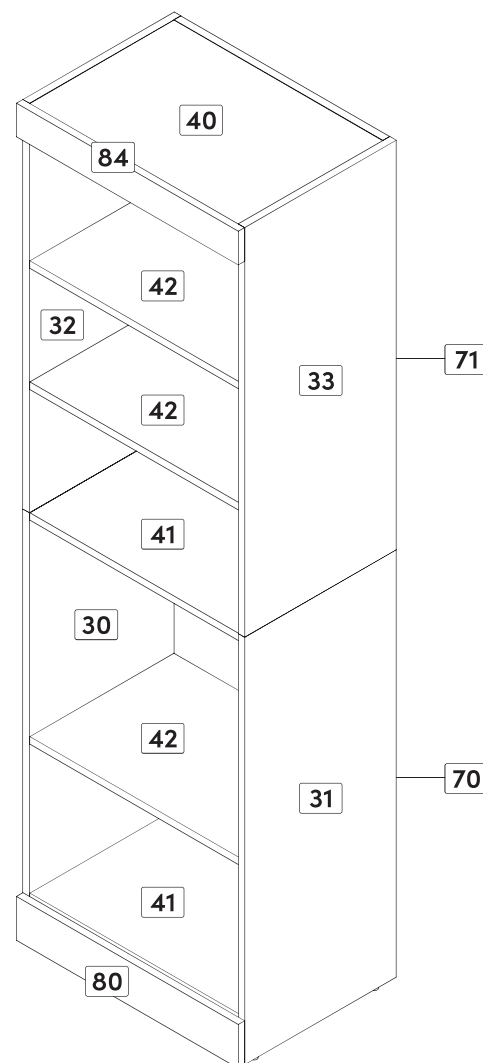

# Important Notice • Note importante • Nota importante

## Main Hardware System. Installation Steps

Système de quincaillerie principal. Étapes d'installation • Sistema principal de quincalla. Etapas de instalación.

**1**

H-36

Push down  
Enfoncez  
Presione

Proper position  
Bonne position  
Buena posición

**2**

Arrow  
Flèche  
Flecha

H-03

Insert the cam with the arrow pointing towards the hole in the edge.  
Insérez la rondelle en pointant la flèche vers le trou de la bordure.  
Inserte la arandela apuntando la flecha hacia el orificio cercano al borde.

How to remove a misplaced assembly bolt (H-36).  
Comment retirer un boulon (H-36) mal situé.  
Cómo retirar un perno (H-36) mal ubicado.

**A**

Turn  
Tournez  
Haga girar

**B**

Pull out  
Retirez  
Retire

**1**

Insert  
Insérez  
Inserte

**2**

Required tools • Outils requis  
Herramientas necesarias

**A**

**3**

Tighten  
Serrez  
Apretar

**B**

**Important**  
Important

Required tools • Outils requis • Herramientas necesarias

1/4 in/po (7 mm)

The use of electric tools must be made with vigilance.  
L'utilisation d'outils électriques doit être faite avec vigilance.  
Las herramientas eléctricas deben utilizarse con sumo cuidado.

**Make sure to properly tighten each cam to ensure furniture solidity. Otherwise, parts could be damaged or the user could be injured.**  
Assurez-vous de bien resserrer chaque rondelle pour assurer la solidité du meuble. Dans le cas contraire, des pièces pourraient être endommagées ou l'utilisateur pourrait se blesser.  
Asegúrese de bien apretar cada tornillo de araña para garantizar la solidez del mueble. De lo contrario, podría provocarse daño a las piezas o las personas.

**TWO people are required to assemble and move this model.**  
DEUX personnes sont requises pour assembler et déplacer ce modèle.  
Se necesitan DOS personas para ensamblar y desplazar este mueble.

1

**Hardware installation • Installation des quincailleries • Instalación de las quincaillas**  
**Library • Bibliothèque • Biblioteca**

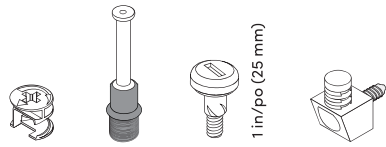

Code • Código	H-03	H-36	PA-844	TI-552
Qty • Qté • Cant.	x 4	x 14	x 4	x 2

**TI-552**

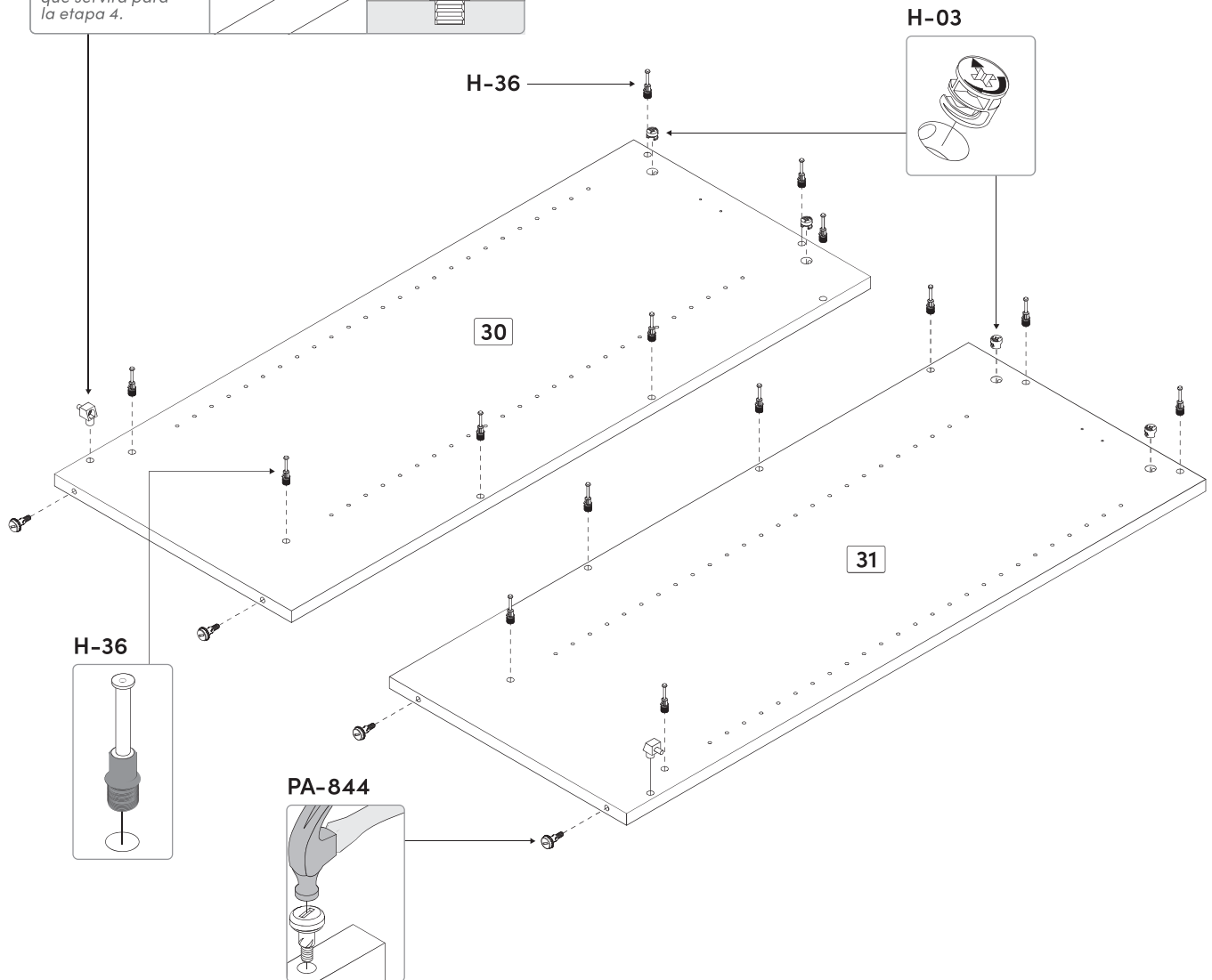
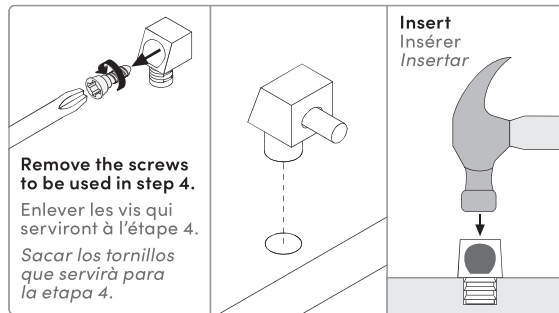

2

Hardware installation • Installation des quincailleries • Instalación de las quincallas  
Library • Bibliothèque • Biblioteca



Code • Código H-03  
Qty • Qté • Cant. x 14

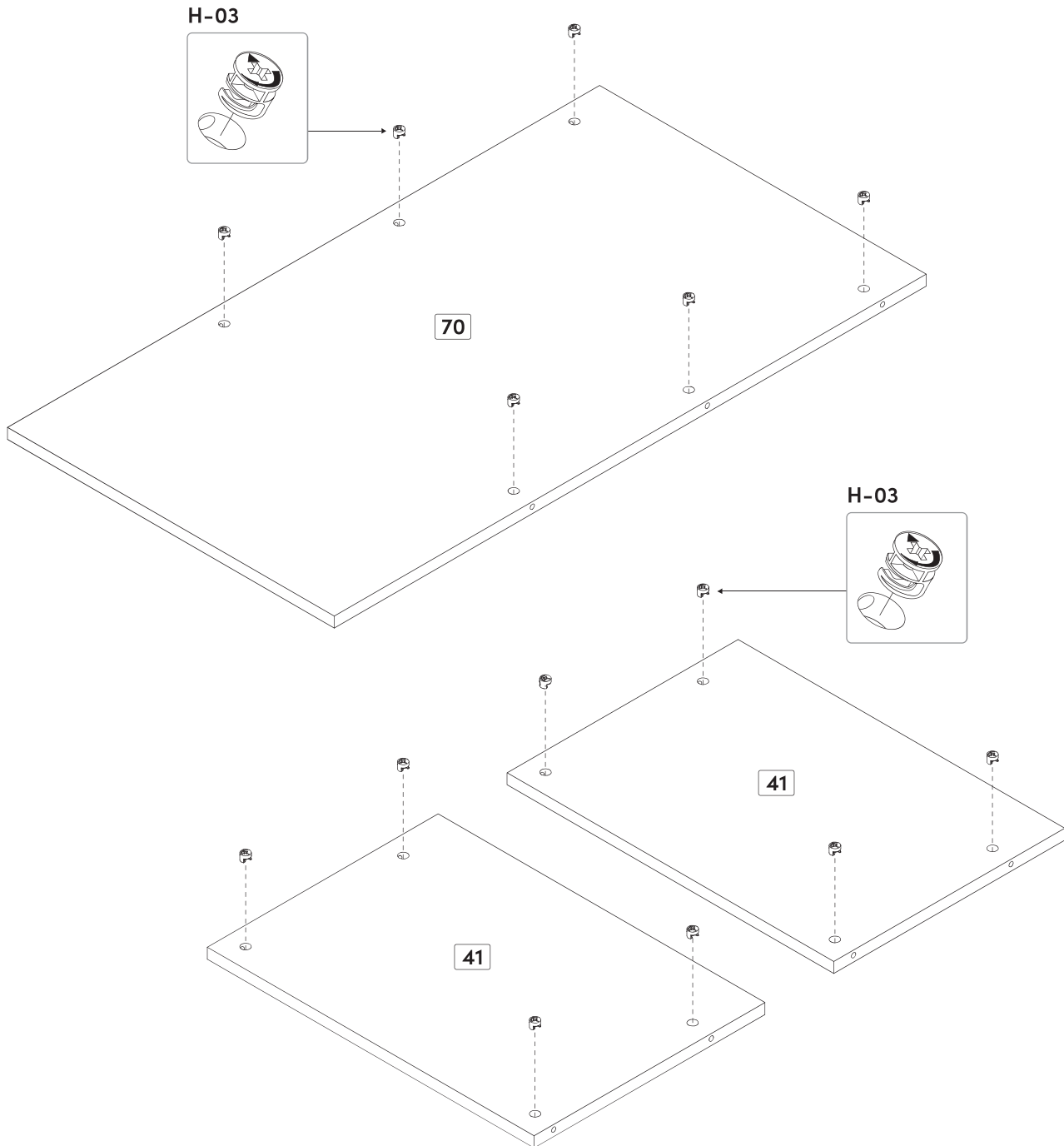

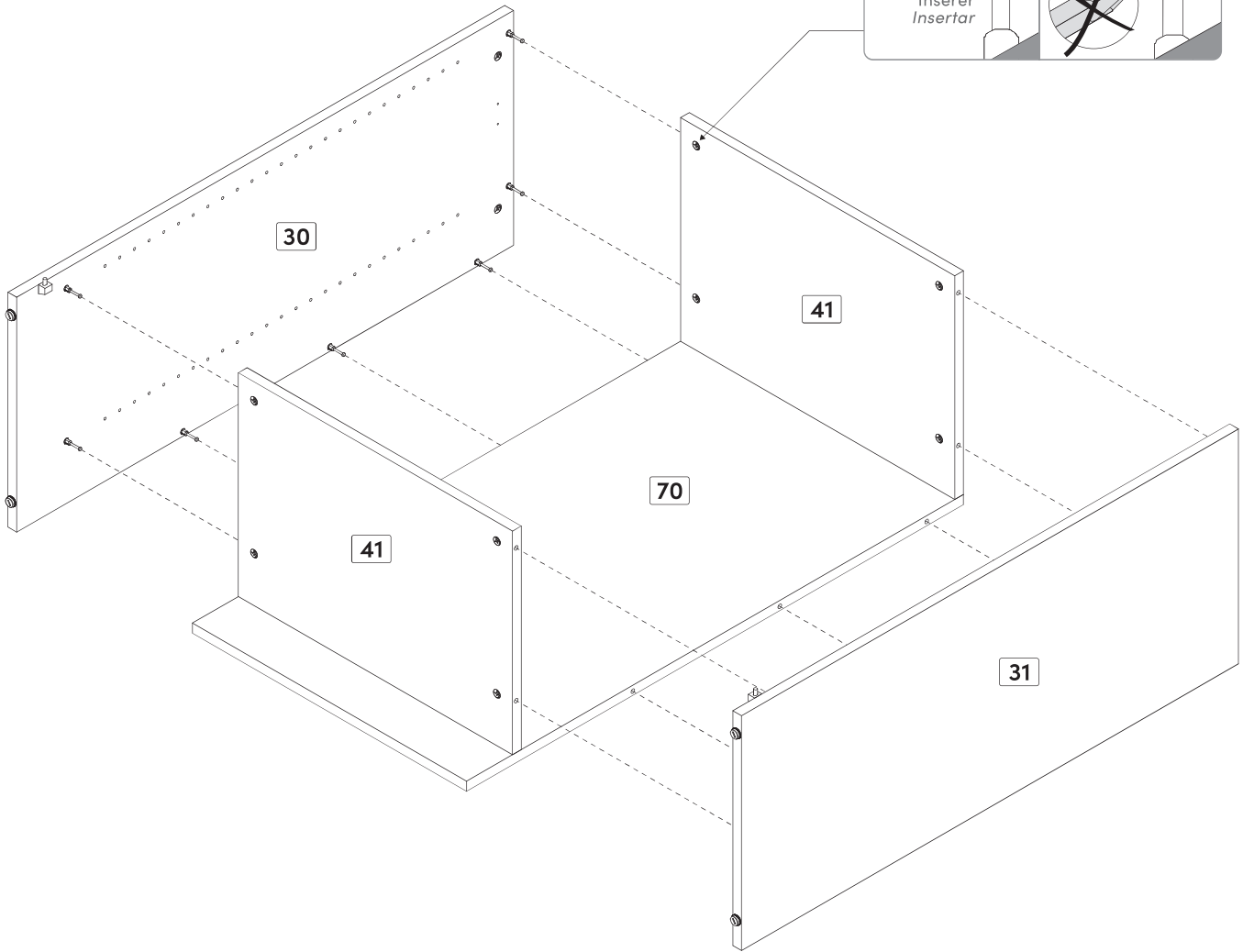
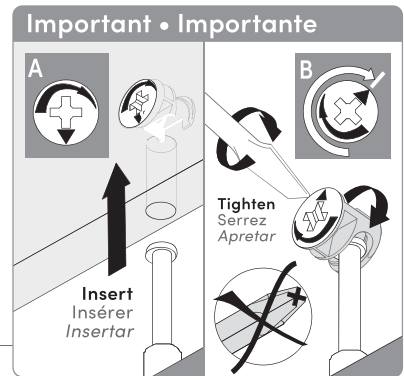

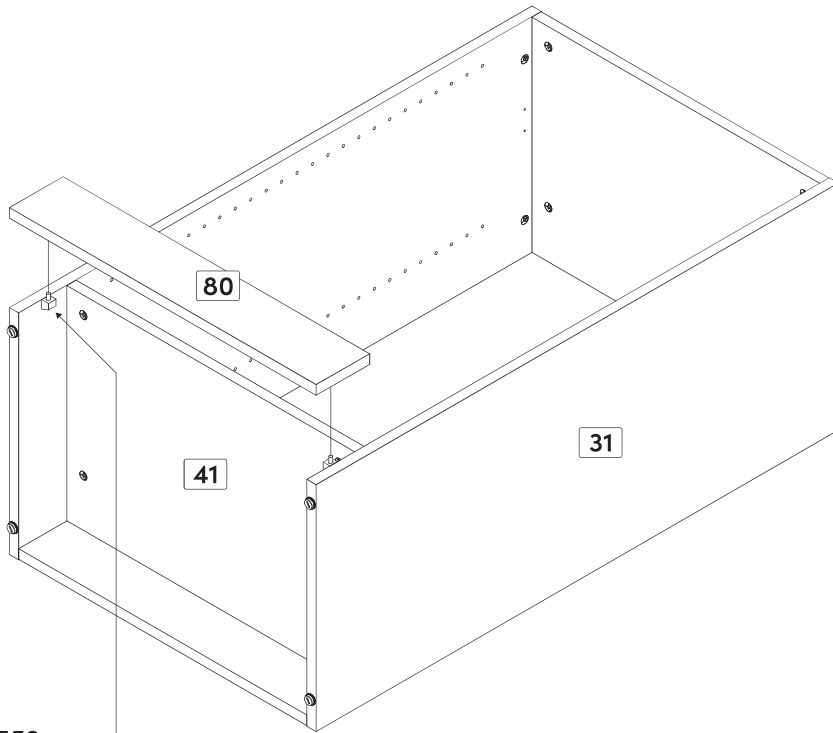

TI-552

Use the remaining screw from step 1.  
Utilisez la vis restante de l'étape 1.  
Use el tornillo restante del paso 1.

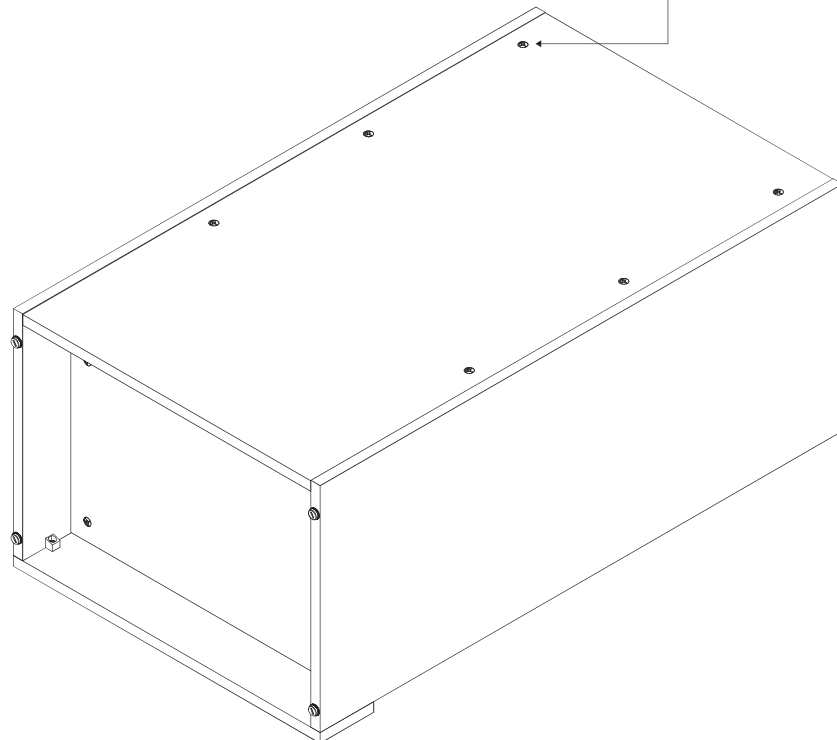
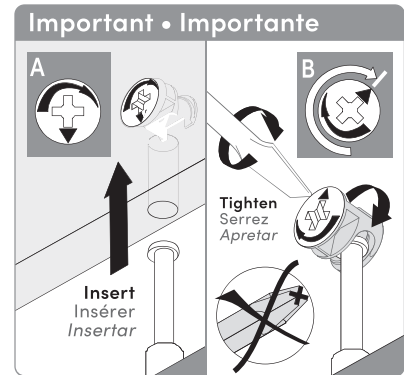
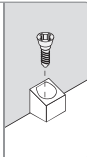

5

Hardware installation • Installation des quincailleries • *Instalación de las quincallas*  
Library • Bibliothèque • *Biblioteca*

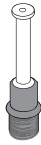

Code • Código      H-36  
Qty • Qté • Cant.    x 14

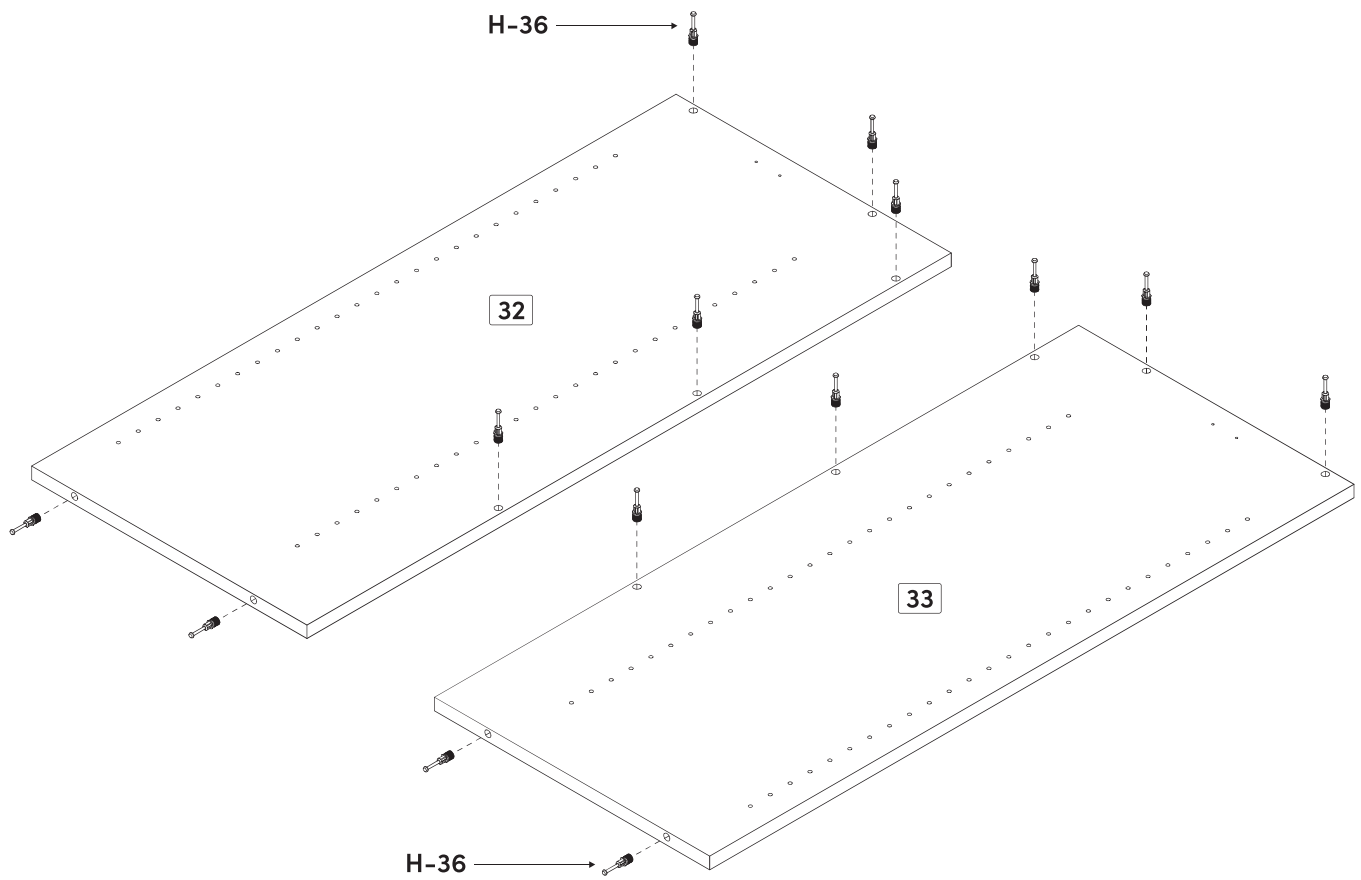



Code • Código

H-03

Qty • Qté • Cant.

x 12

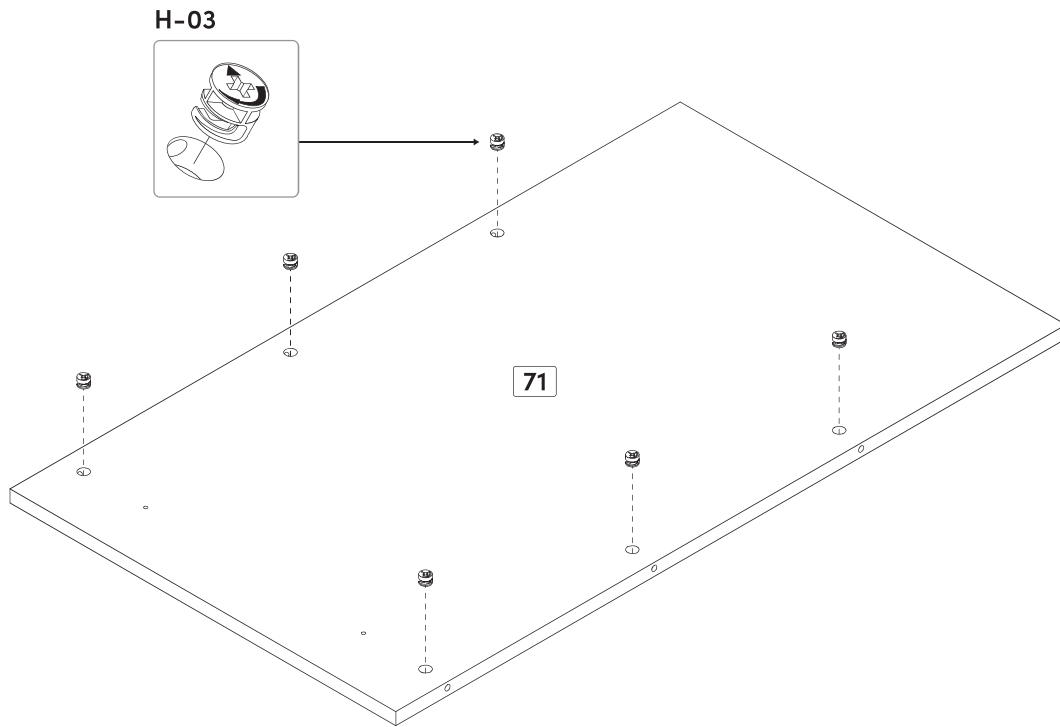

**H-03**

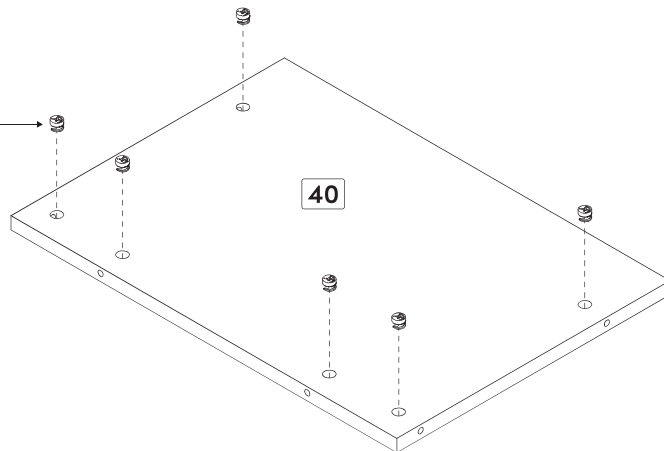
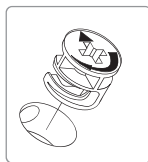

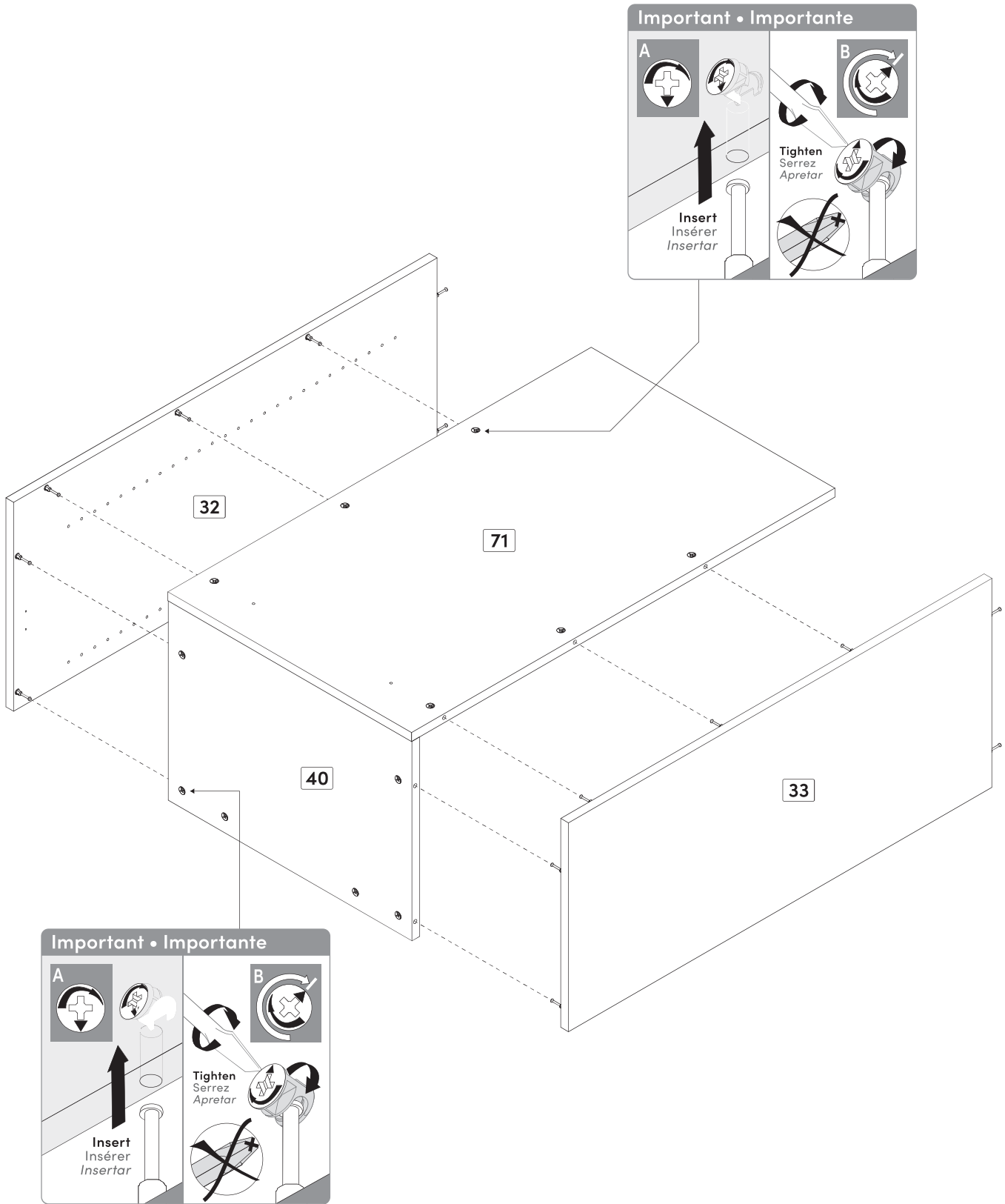

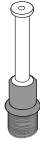

Code • Código **H-36**

Qty • Qté • Cant. **x 2**

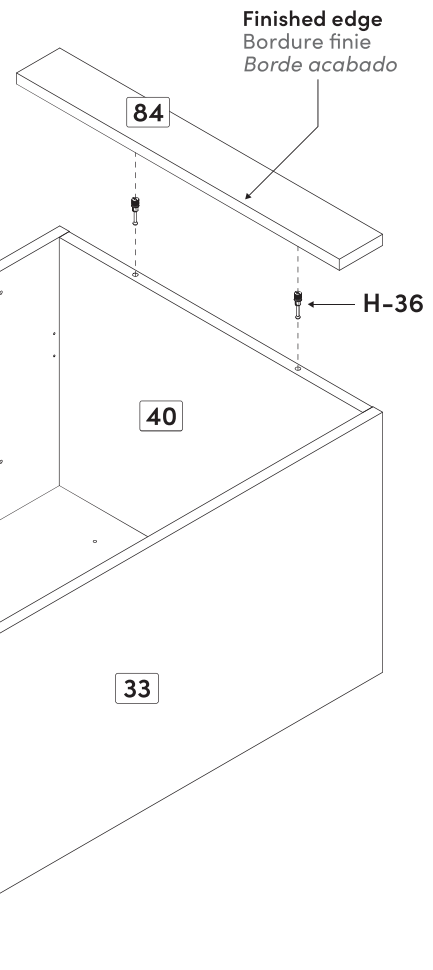
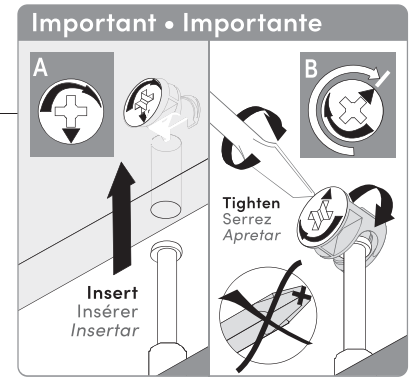
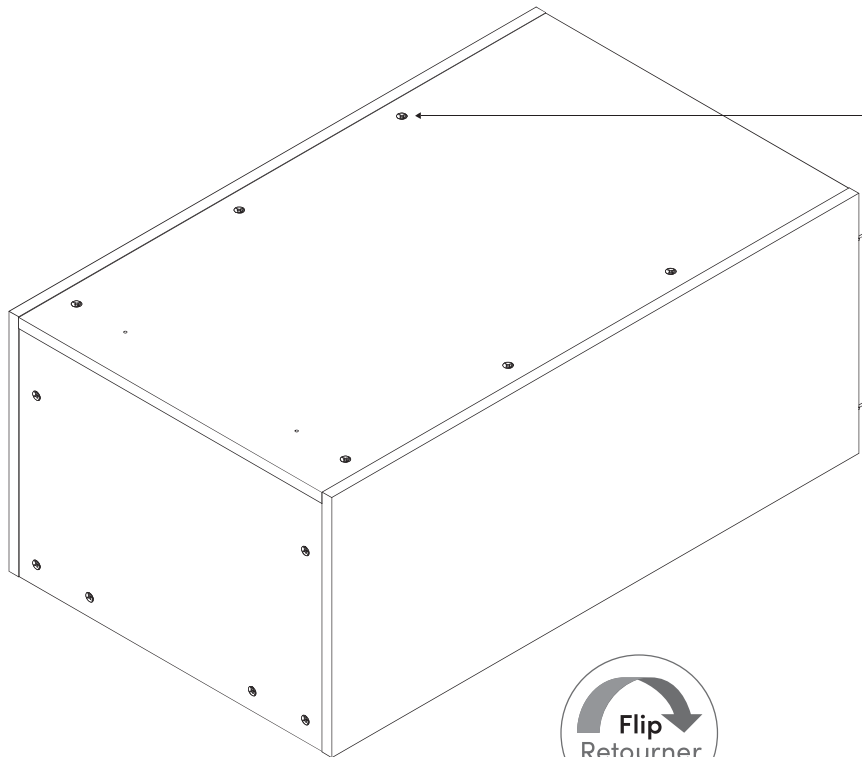

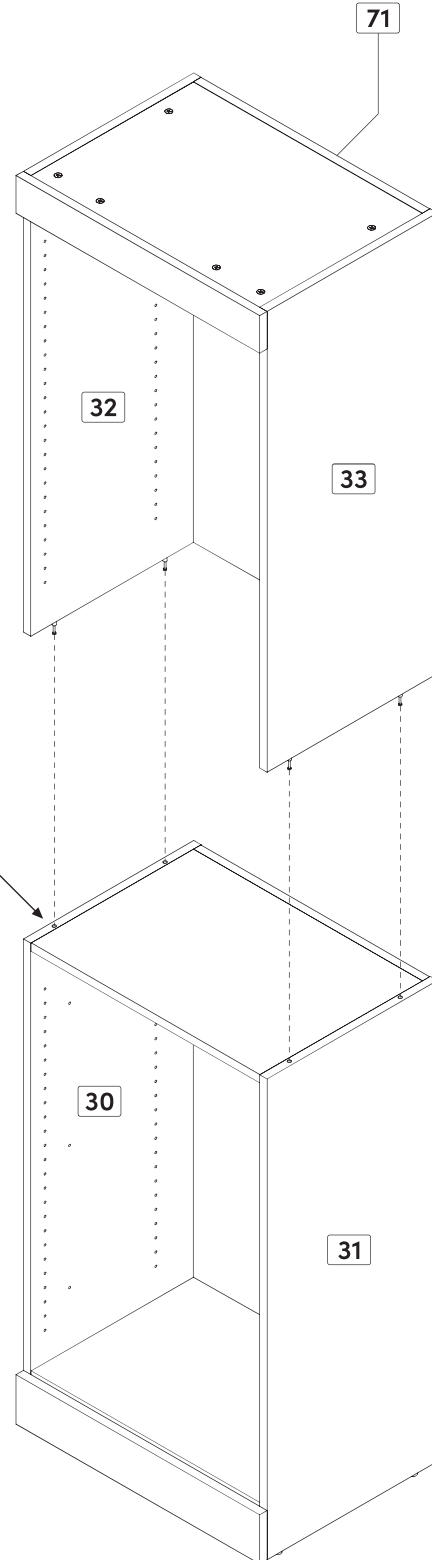
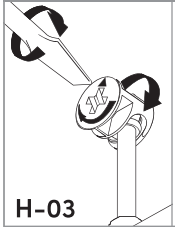
**Important • Importante**

**Remember to tighten the H-03 located on parts 30 and 31.**

N'oubliez pas de serrer les H-03 qui sont situées sur les pièces 30 et 31.

No se olvide de apretar las H-03 que se encuentran en las piezas 30 y 31.

**H-03**

**10 WALL ANCHORING INSTRUCTIONS** Alone  
**PRESCRIPTIONS D'ANCRAGES** Seul  
**INSTRUCCIONES PARA EL ANCLAJE A LA PARED** Sólo

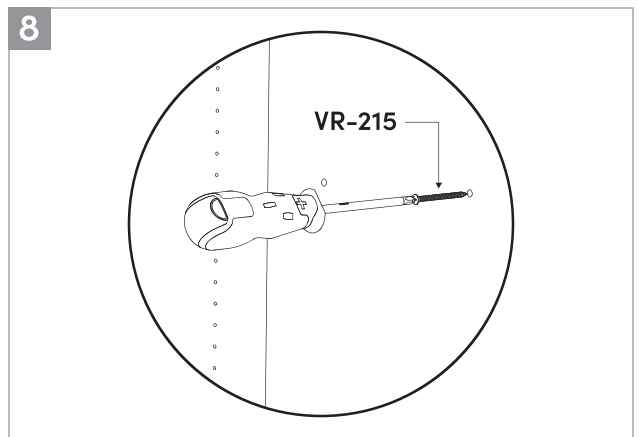
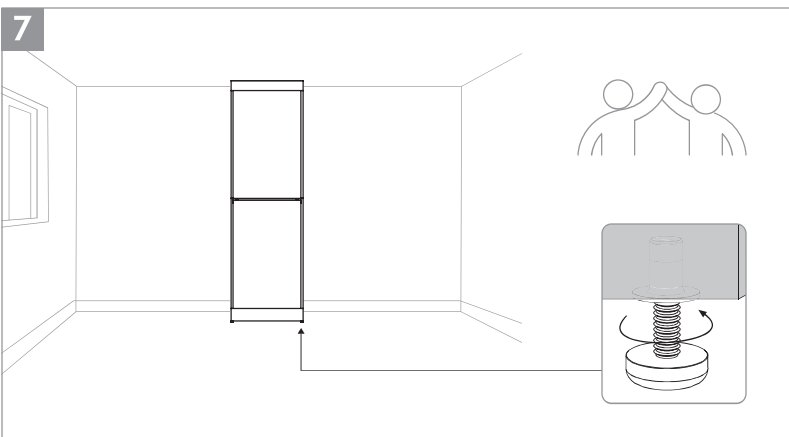
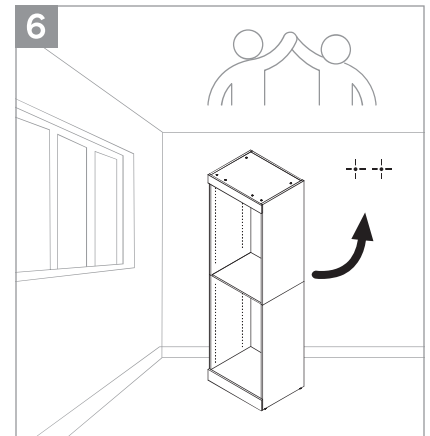
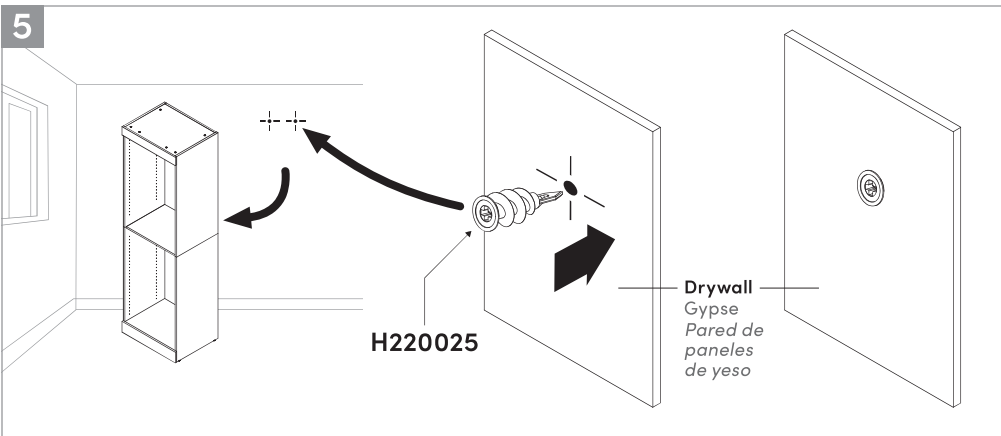
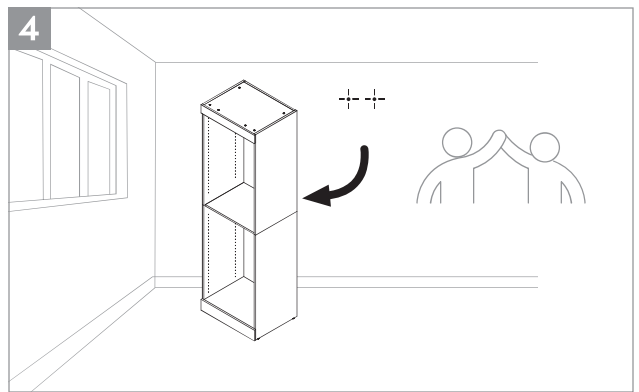
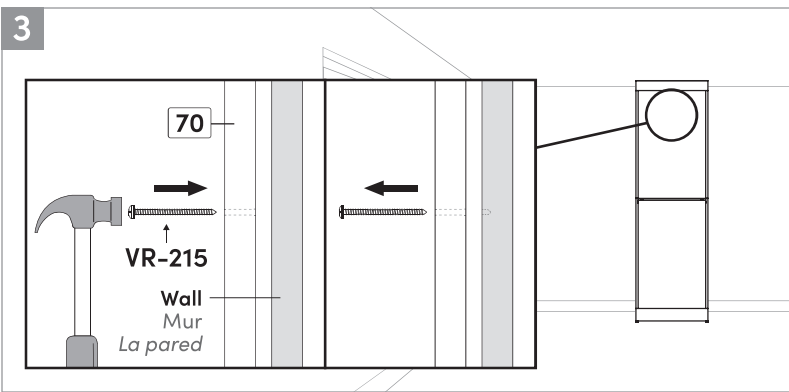
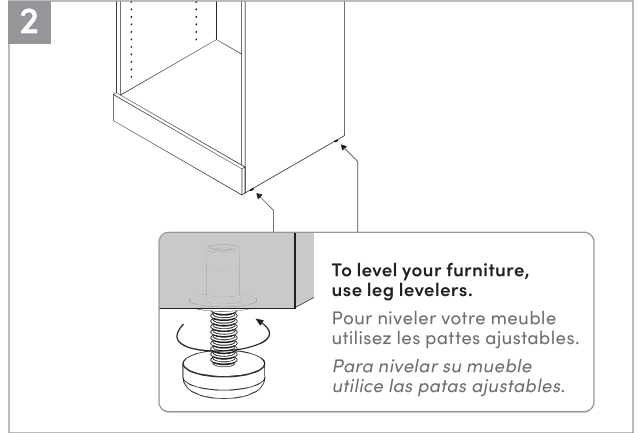
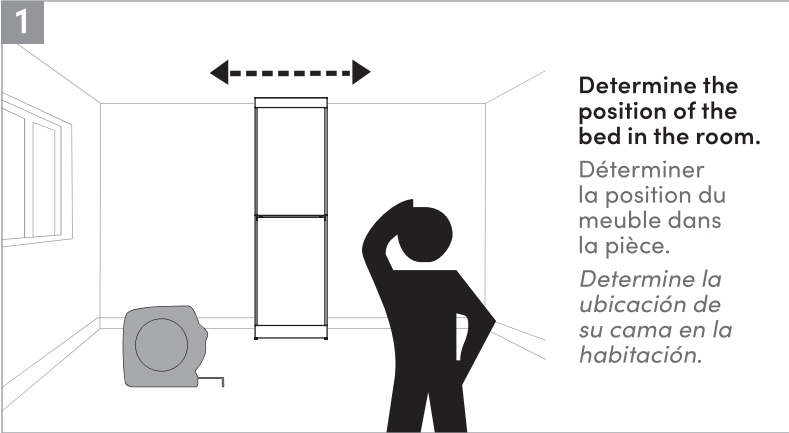

**11 WALL ANCHORING INSTRUCTIONS** Combo  
**PRESCRIPTIONS D'ANCRAGES** Combo  
**INSTRUCCIONES PARA EL ANCLAJE A LA PARED** Combo

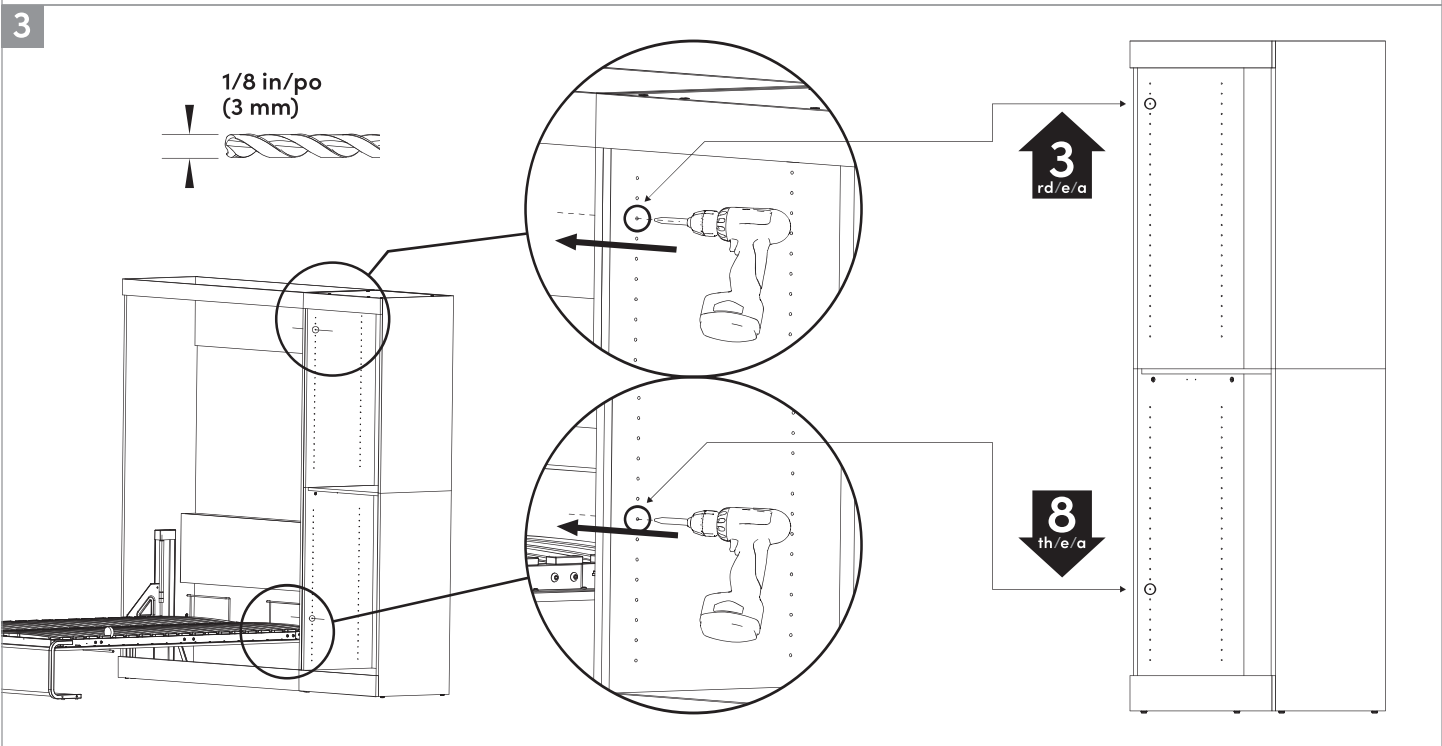
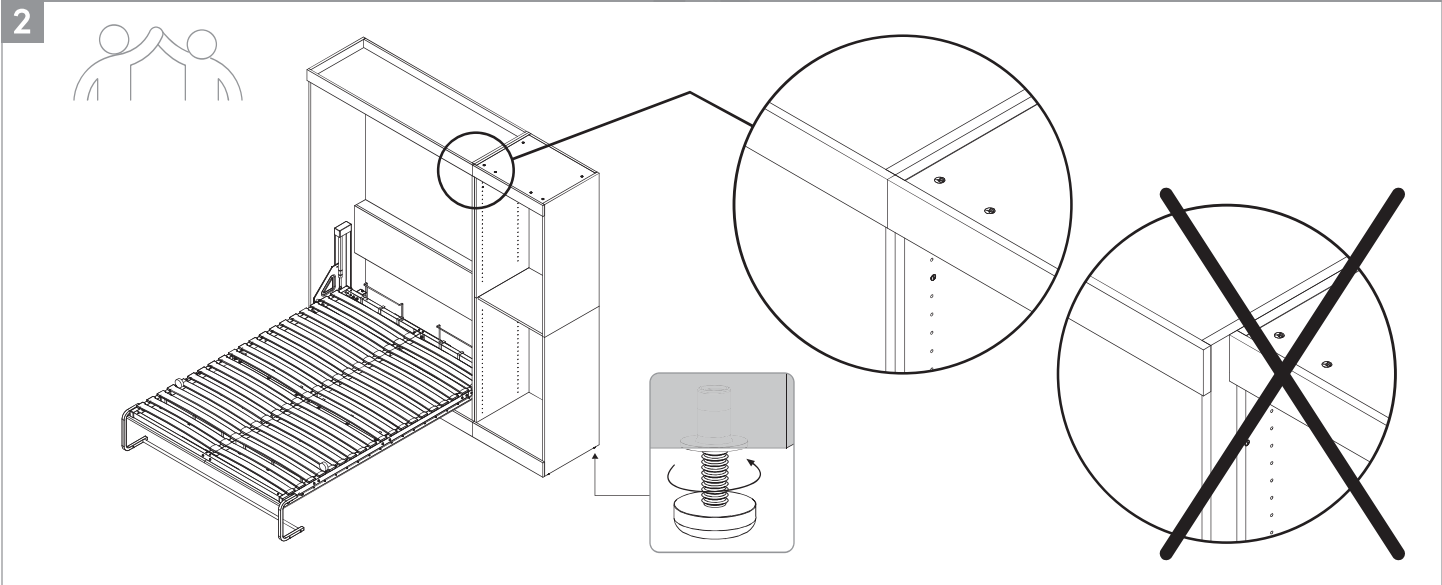

**WALL ANCHORING INSTRUCTIONS** Combo  
**PRESCRIPTIONS D'ANCRAGES** Combo  
**INSTRUCCIONES PARA EL ANCLAJE A LA PARED** Combo

4

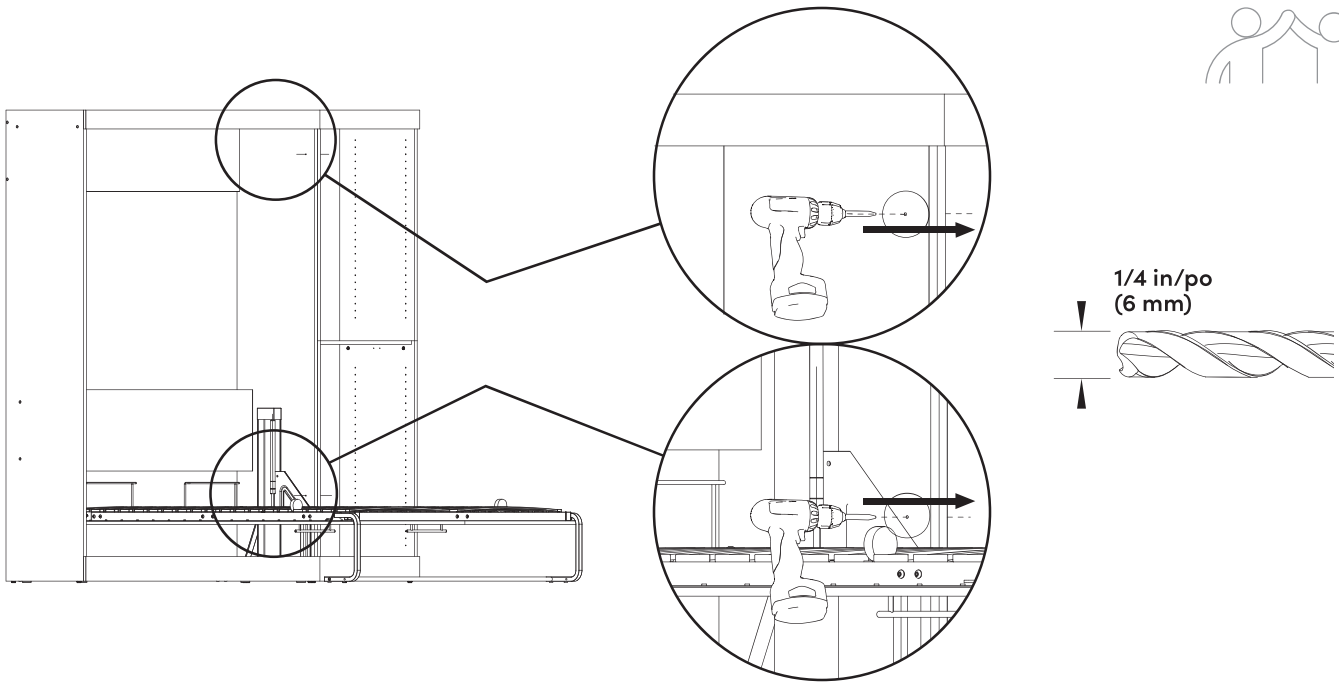

5

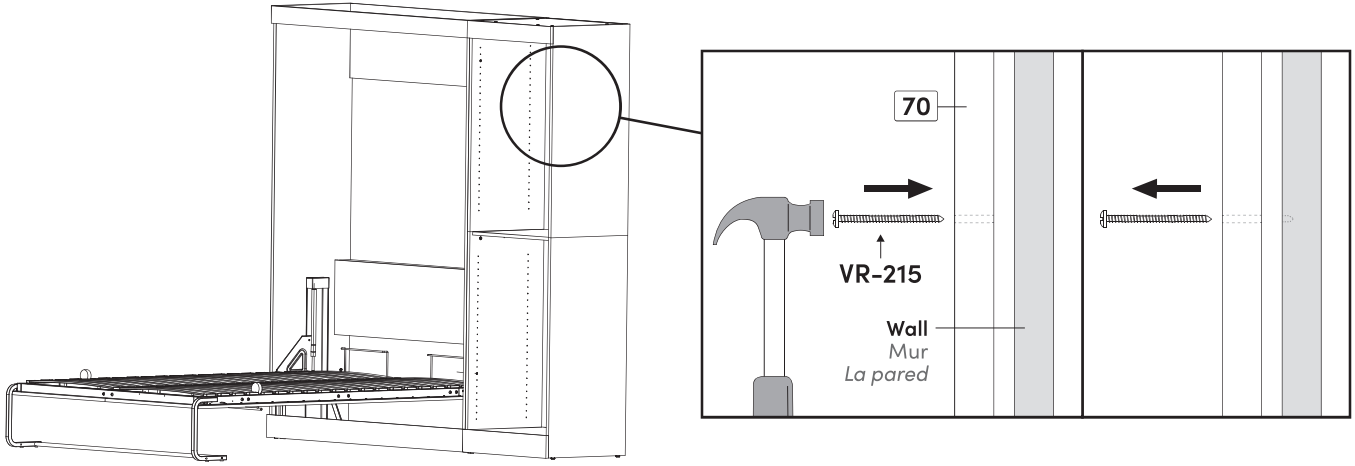

6

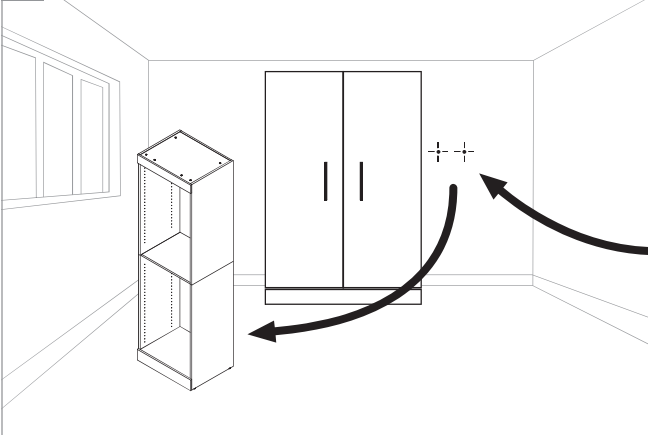

7

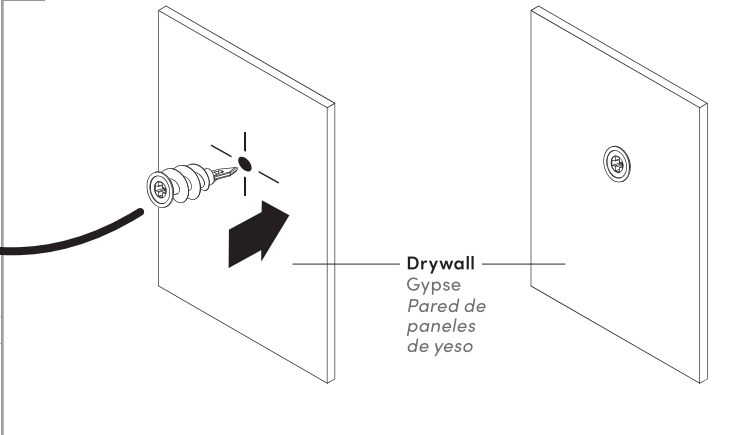

**WALL ANCHORING INSTRUCTIONS** Combo  
**PRESCRIPTIONS D'ANCRAGES** Combo  
**INSTRUCCIONES PARA EL ANCLAJE A LA PARED** Combo

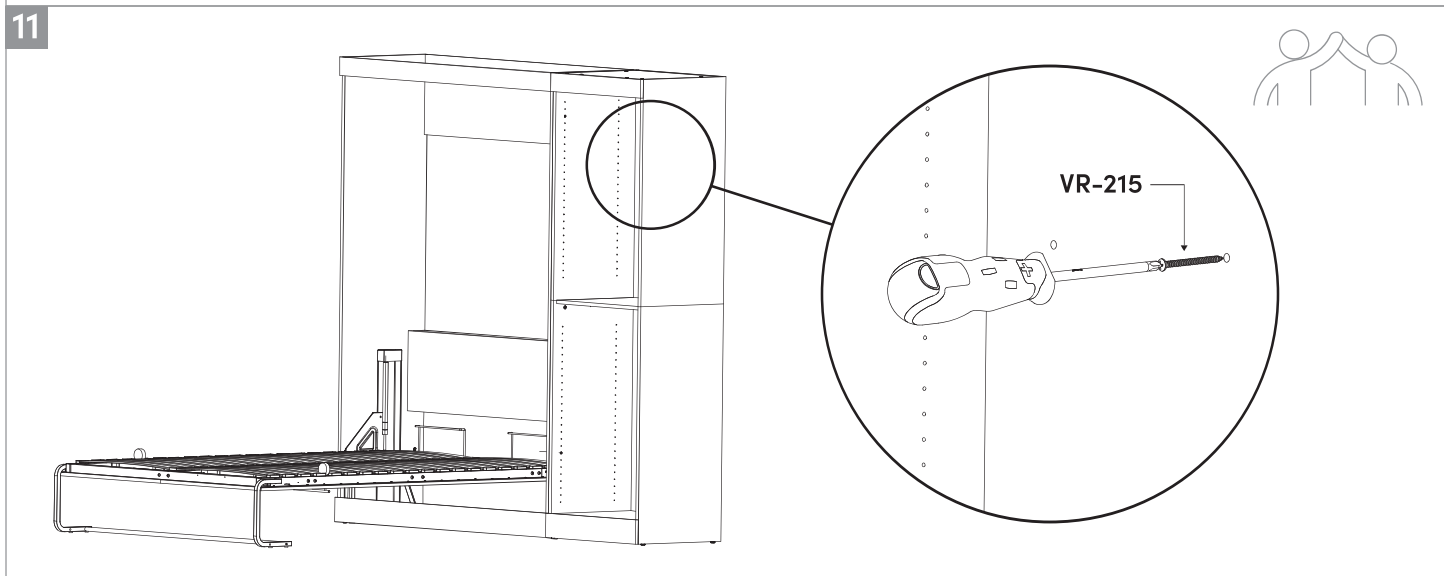
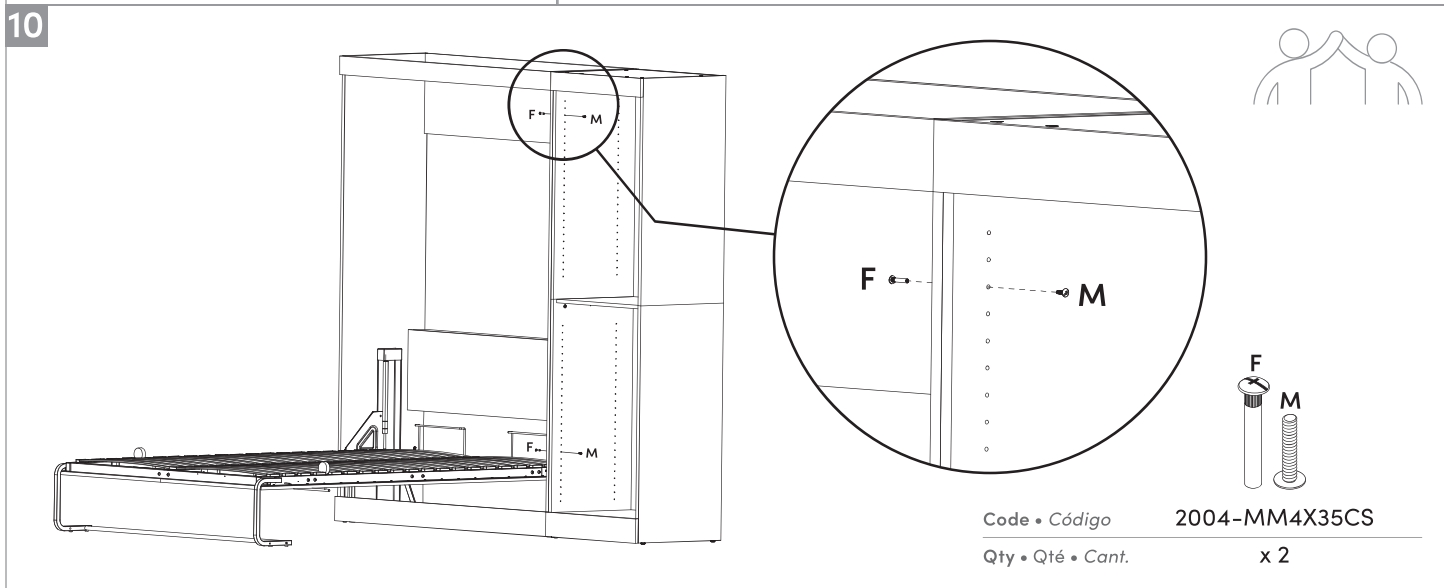
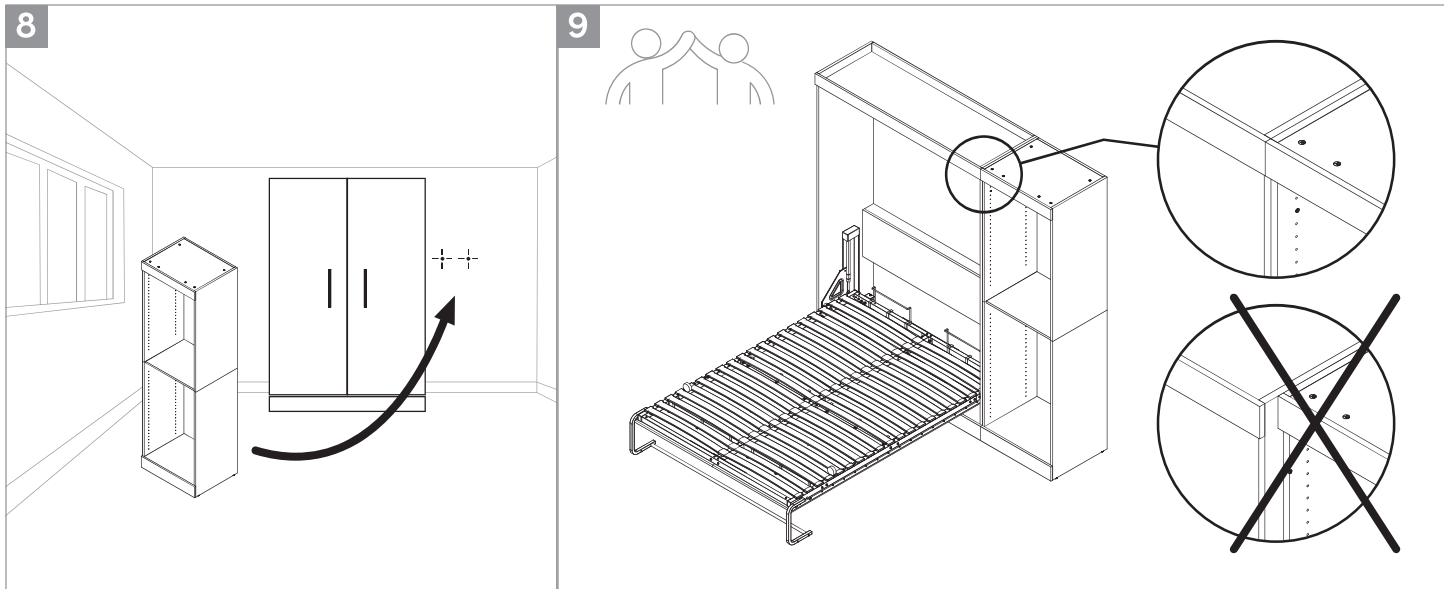

**12 Hardware installation & assembly** • Installation des quincailleries et assemblage • *Instalación de las quincallas y ensamblaje*  
**Library** • Bibliothèque • *Biblioteca*

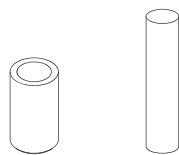

Code • Código	H126396	TI-118
Qty • Qté • Cant.	x 12	x 12

