

Assembly Instructions.

CAUTION: You must read these Assembly Instructions before you proceed.

Please look in the Leg Panel for Hardware Packs.

Table.

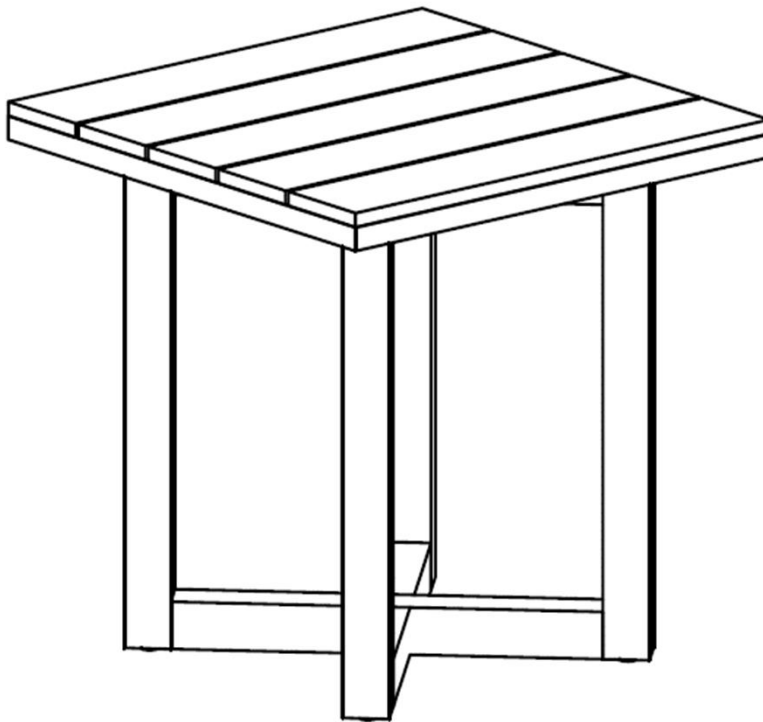



CAUTION: This Table is NOT a TOY.

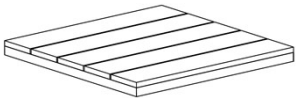
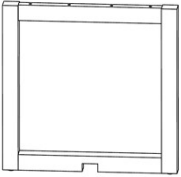

Keep your child/children at bay during the assembly process.

For moving the Table and to prevent damage to the Table, two adult partners may be needed to execute these actions.

Parts List:

| Label | Picture | Description | QTY |
|-------|--|-------------------------------|-----|
| A |  | Table Top | 1 |
| B |  | First Leg Panel (Labelled B) | 1 |
| C |  | Second Leg Panel (Labelled C) | 1 |

Hardware List:

| Label | Picture | Description | QTY |
|-------|---|---------------------|-----|
| ① |  | Bolt (M6 x 30mm) | 2 |
| ② |  | Bolt (M6 x 50mm) | 9 |
| ③ |  | Allen Wrench | 2 |

Assembly Preparation:

Before Beginning Assembly:

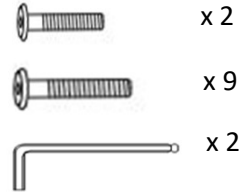
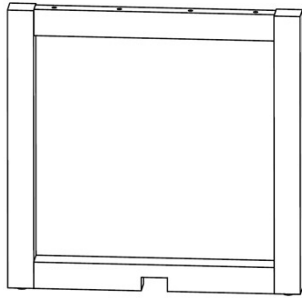
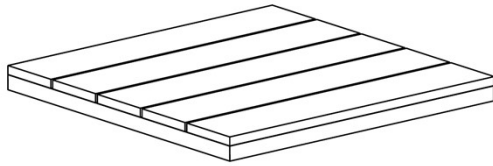

- Read instructions, cover to cover-



- Have 2 adult partners on hand for assembly-



- Do not assemble on flooring or carpet-



- Assemble on a clean non-marring surface (packing foam)-



- Save all packaging until finished-

Assembly Steps:

OVERVIEW

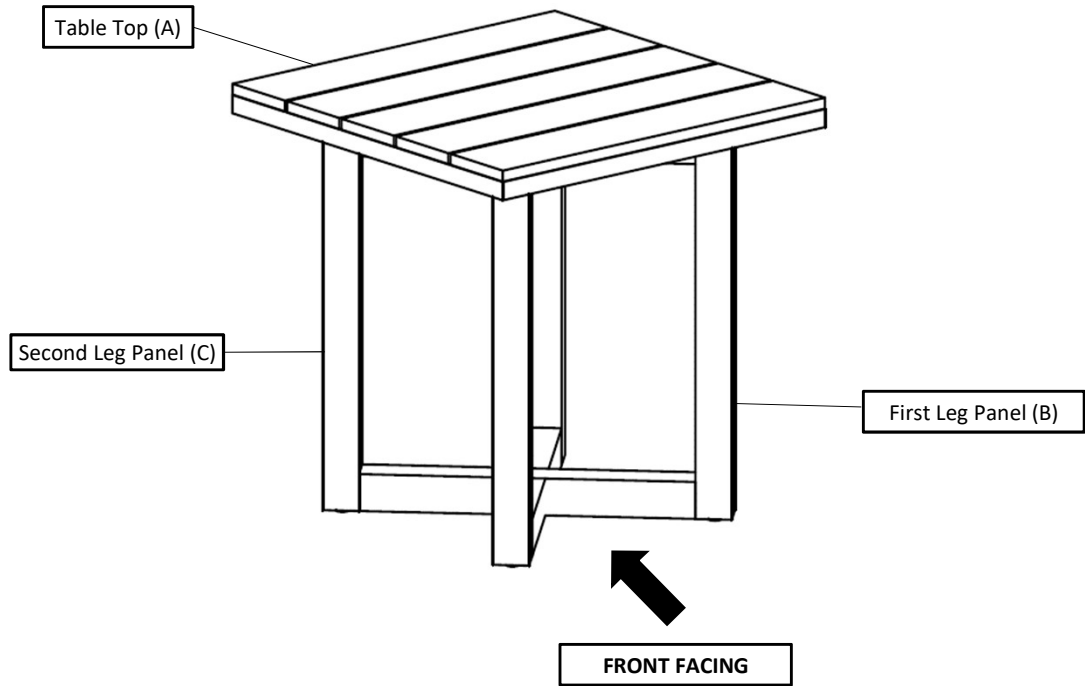

This Table has multiple parts and may require up to some 30 minutes to assemble. To give you an overview of the Table parts, the above picture is to help you put the various parts into perspective. Please read through the instructions below to familiarise yourself with the parts and steps before assembly.

Step 1

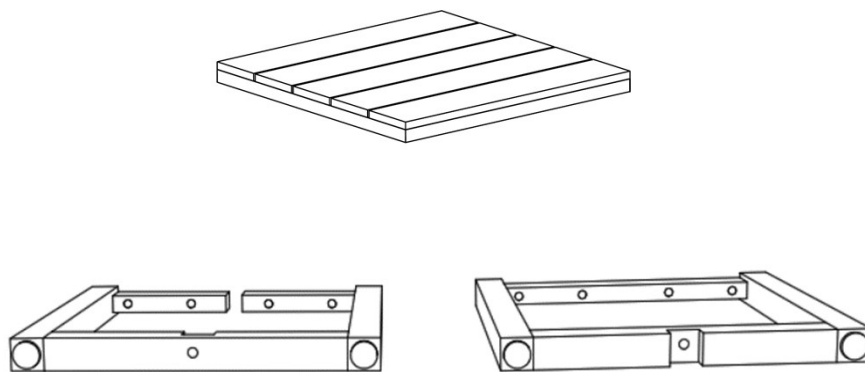

Unpack and place all parts on a clean, non-marring surface.

Step 2

Step 2.1

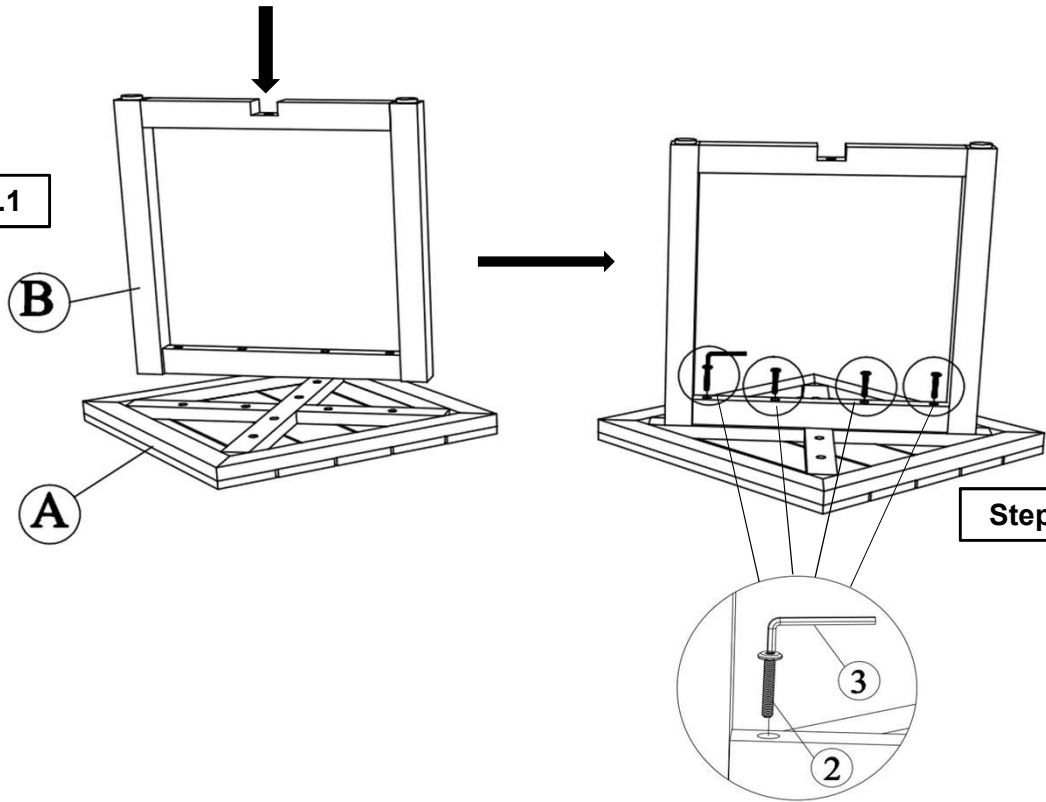

Step 2.2

With assistance from your adult partner, place the Table Top(A) facedown on a clean, non-marring surface.

2.1) Position the First Leg Panel(B) onto the Table Top(A) as shown above.

2.2) Insert 4 Bolts(②), through the mounting positions of the First Leg Panel(B) and affix it using the Allen Wrench(③).

DO NOT fully tighten the Bolts.

Step 3

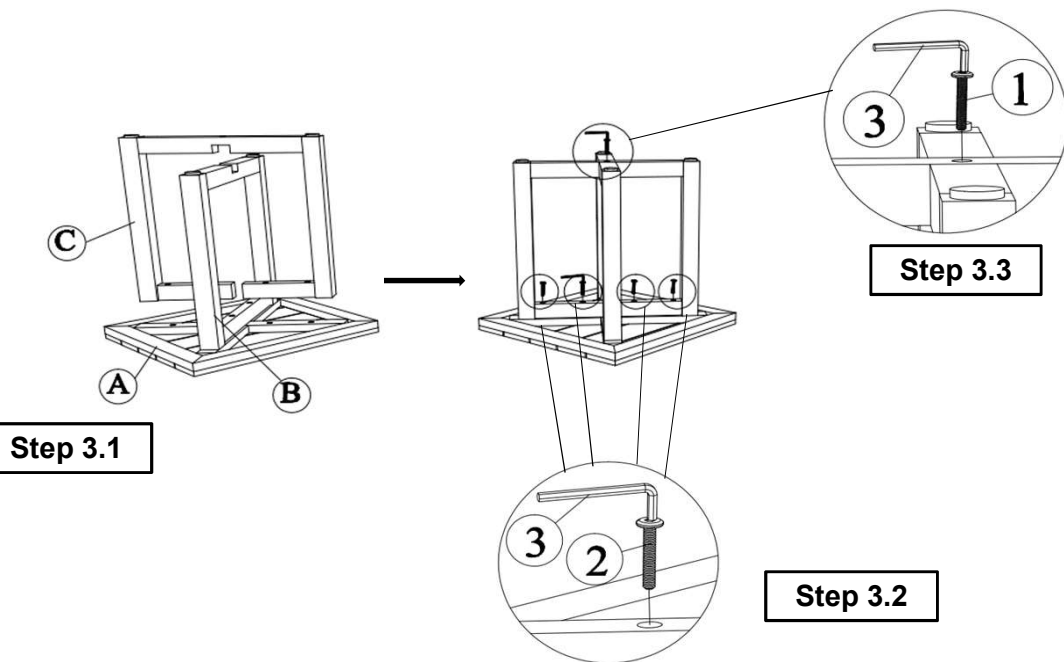

Step 3.1

Step 3.3

Step 3.2

With assistance from your adult partner,

3.1) Position the groove point of the Second Leg Panel(C) over the First Leg Panel(B) of the assembled part in Step 2. **3.2)** Insert 4 Bolts(②) through the mounting positions of the Second Leg Panel(C) into the Table Top(A) and affix it using the Allen Wrench(③).

3.3) Affix the First Leg Panel(B) to the Second Leg Panel(C) using Bolts(①) and the Allen Wrench(③).

DO NOT fully tighten the Bolts.

Step 4

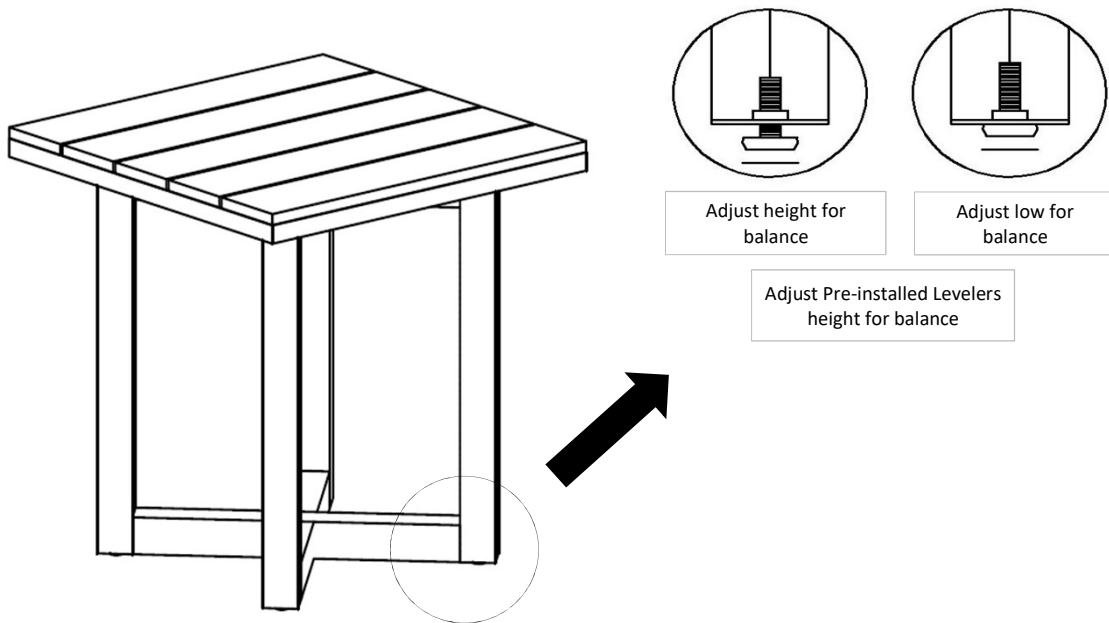

With assistance from your adult partners, Turn the Table over.
EXERT pressure, floorwards onto the Table with both hands.
This pressure will help the Table reach full alignment at all joints.
Check for wobbles.

In a sequential manner, gradually tighten all Bolts at all joints until evenly secured. Inspect the Table and make sure all parts are adequately connect.

CAUTION: When tightening the Bolts tighten sequentially.

DO NOT tighten any Bolt fully and then move towards the next one. This could cause the frame to warp.

If there are still wobbles after tightening, loosen the Bolts and execute the same above process.









With assistance from your adult partners, adjust the Levelers to the desired height to avoid wobbles.

If the Table is not stable, it could lead to damage of the product.

Your Table is ready for use.

This Table can only be used on a flat, level surface.

Care & Maintenance

-  ● Do not put hot items directly on furniture surface
 -  ● Do not clean furniture with harsh cleansers or polish.
 -  ● To obtain the longest lifespan of your outdoor products, minimizing exposure to direct sunlight is recommended.
 -  ● Children should not climb or jump on the furniture.
 -  ● Do not write on furniture without a padded barrier to protect the surface.
 -  ● To obtain the longest lifespan of your outdoor products, avoid extended and lengthy exposure to rain, snow, and direct sunshine. Whenever possible cover the product and /or place under patio or awnings.
 -  ● Not for commercial use. For residential use only .
 -  ● Stains may be removed with mild soap solution and damp cloth.
-
-  ● Dust and pick-up spills using a clean, non-colored, lint-free cloth .