

42212/ 42214 Bench

Revision Number: 01

E1900111, E1900112, E1900113

E1900117, E1900118, E1900119

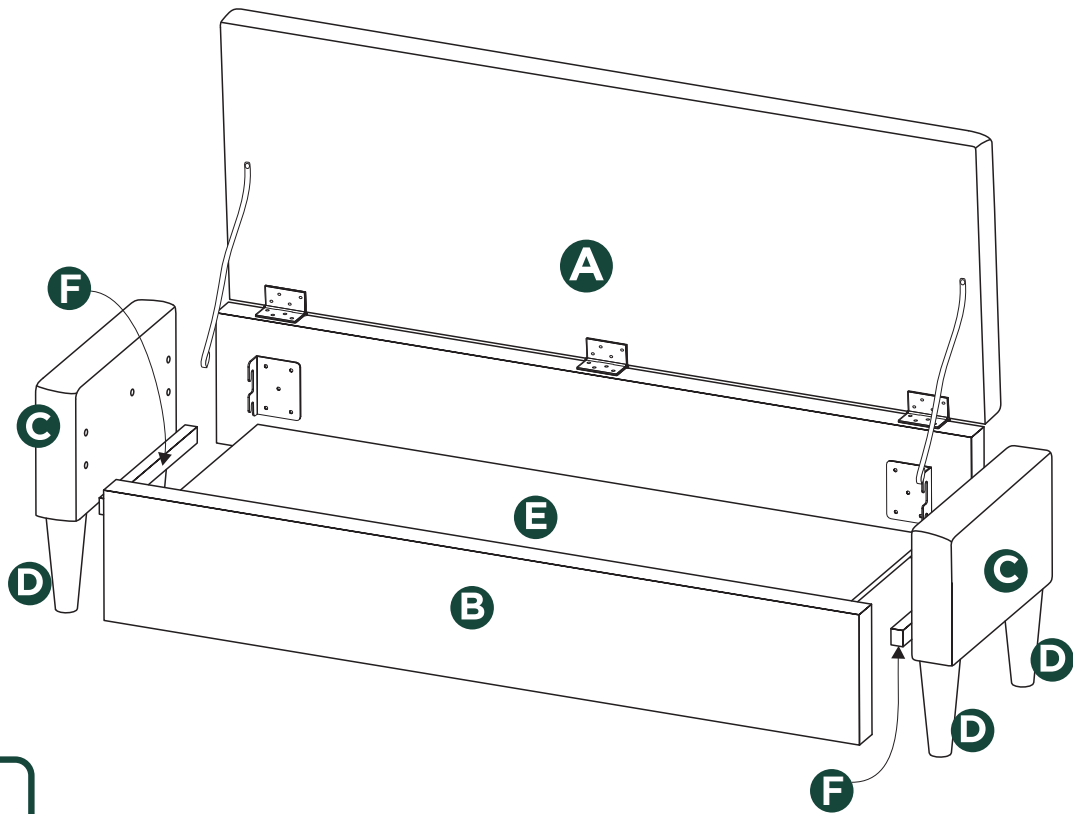

Components

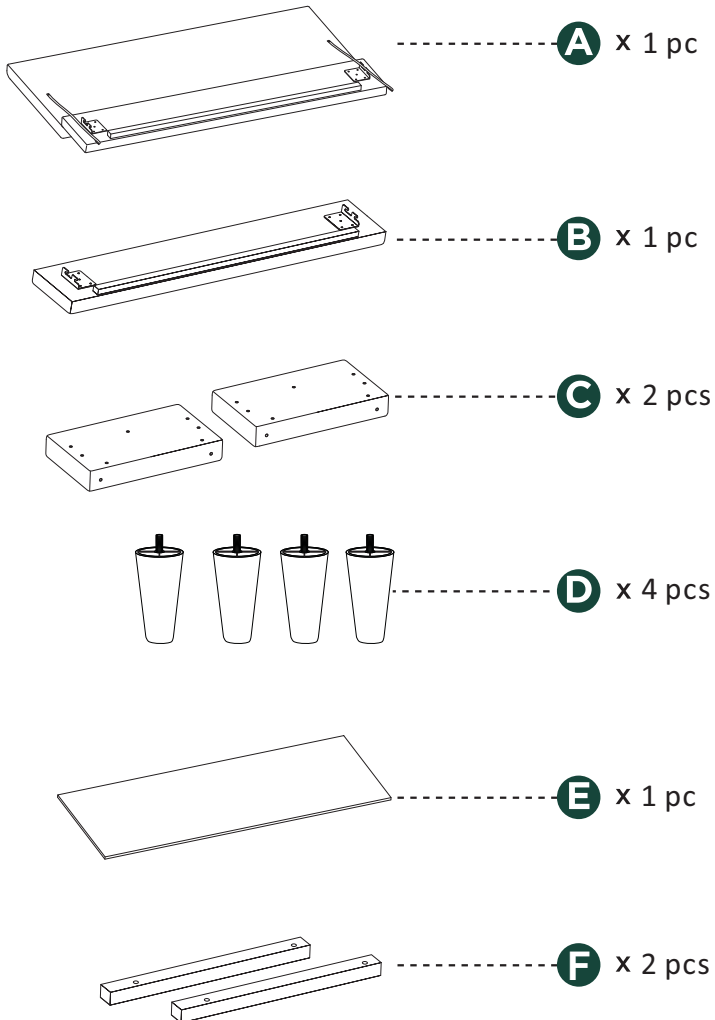

Hardware

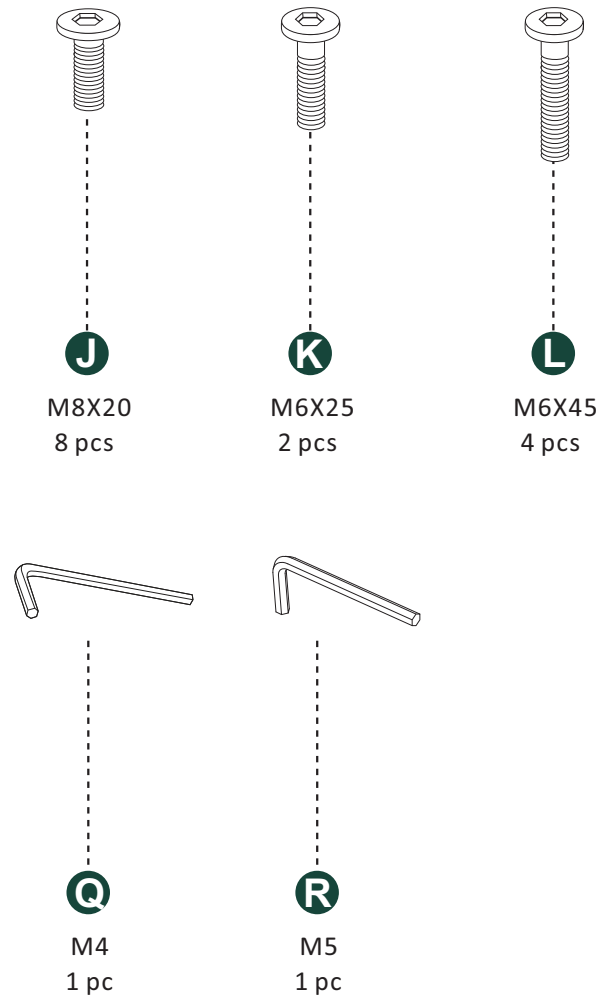

1

Attach the cleats (F) to the end panels (C) as shown below. Use the bolts (L) to attach. Tighten with Allen key (Q).

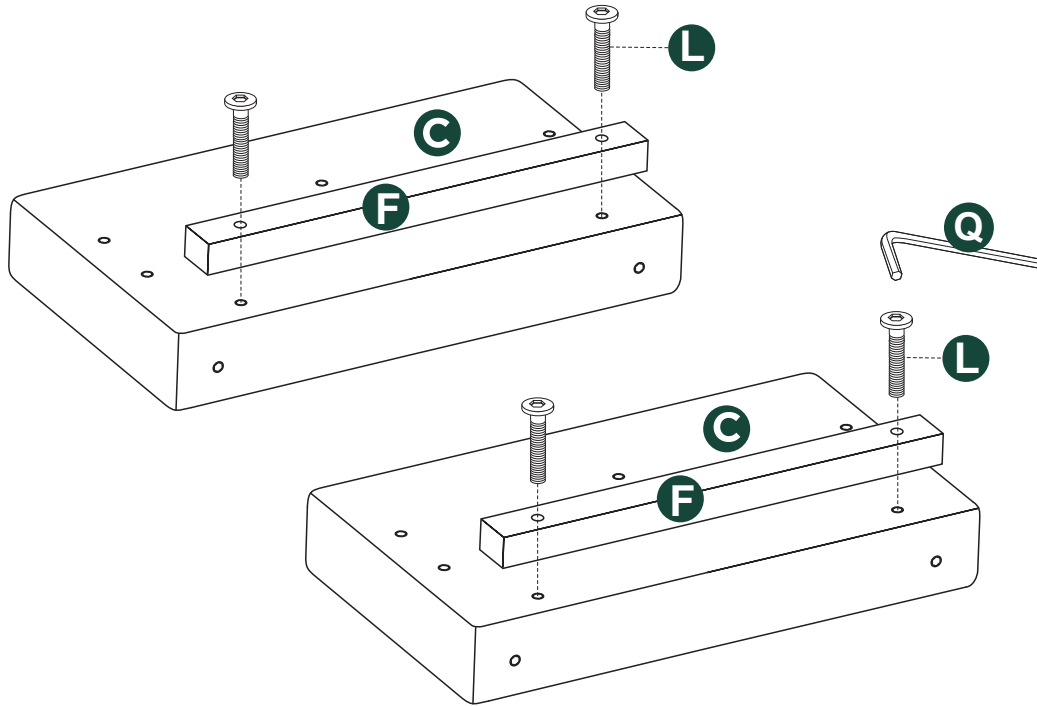
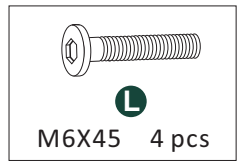
**2**

Thread the bolts (J) to the end panel (C) as shown below, tighten with Allen key (R). Thread the bolt (K) to end panel (C) as shown below, tighten with Allen key (Q). Do not tighten all these bolts. These will be tightened in later steps. Attach legs (D) to bottom of end panel (C) as shown below.

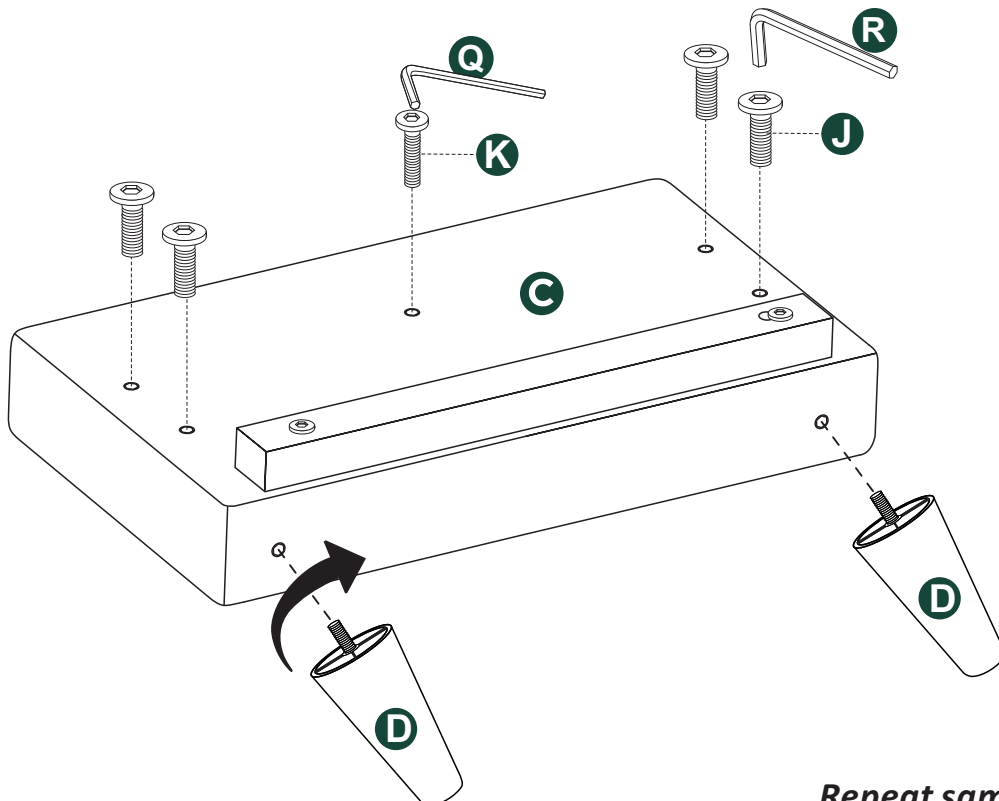
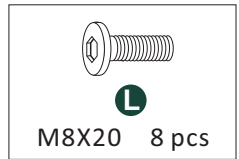
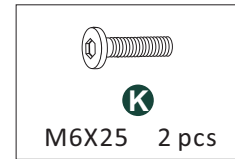

Repeat same steps to assemble another end panel (C).

3

Hang the hooks at the ends of component (A) onto the (J) bolts in the end panels (C). Do not fully tighten the (J) bolts. The bolts will be fully tightened in a later step.

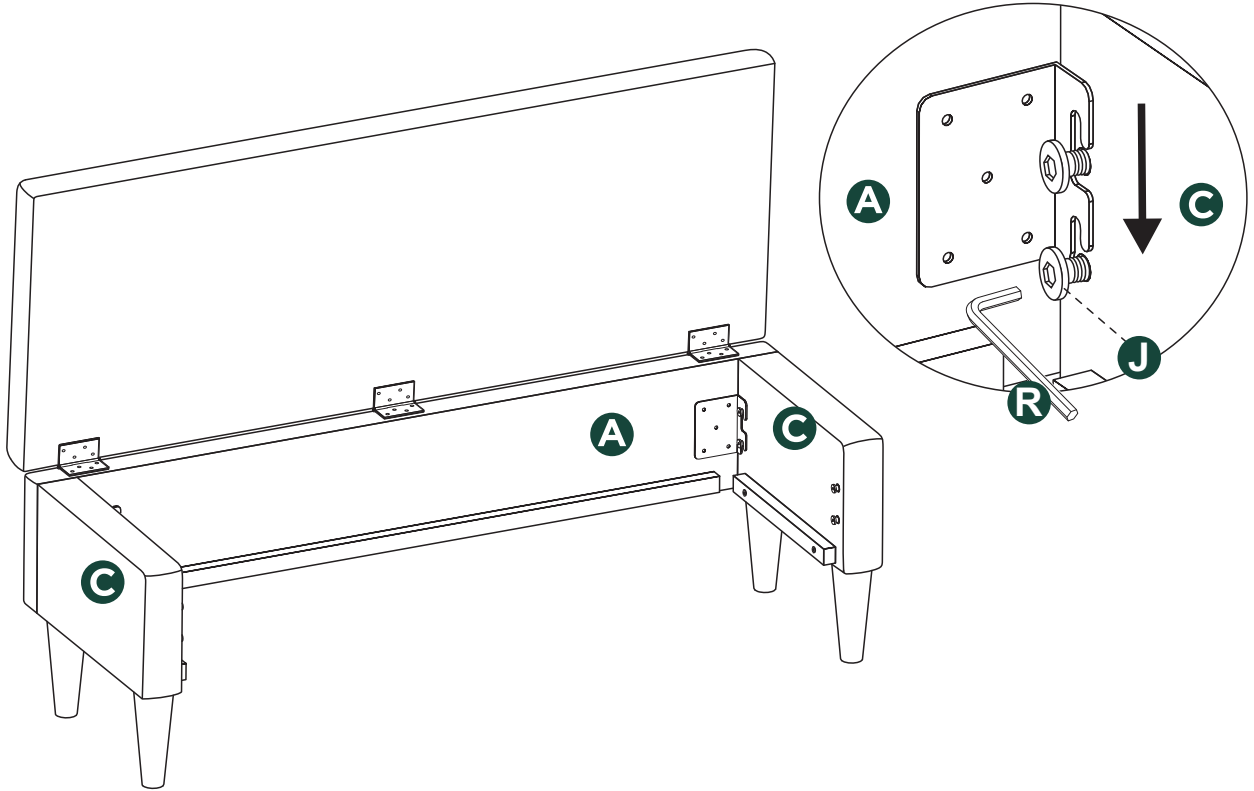

4

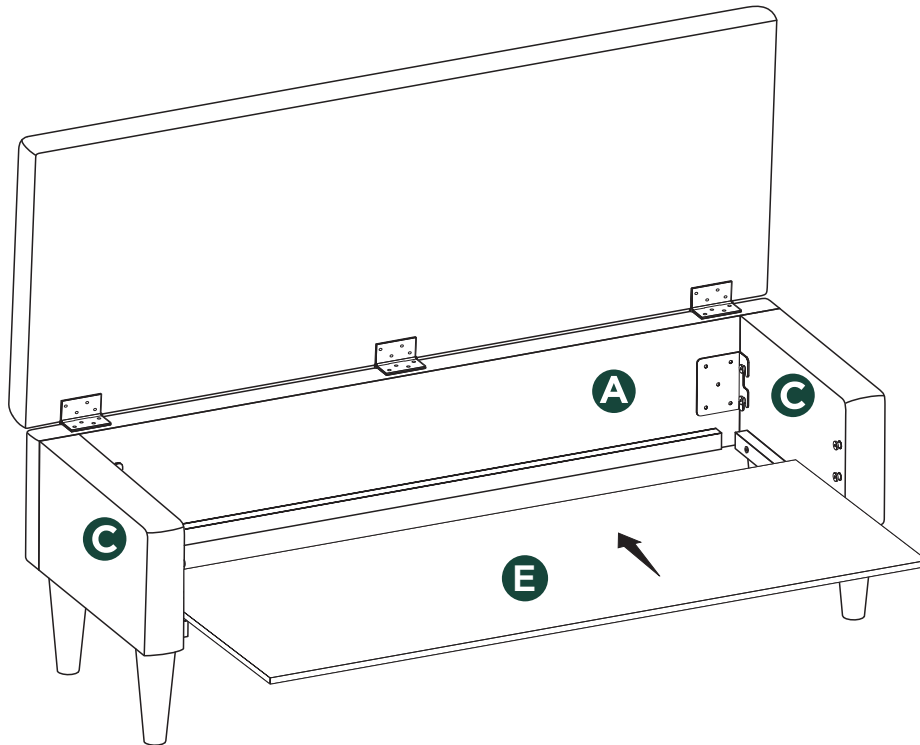

Insert bottom panel (E) onto cleats as shown below.

- 5** Attach panel (B) to hold the bottom panel (E) as shown below in “Figure shown from bottom” to hang the hooks at the ends of panel (B) onto the (J) bolts in the end panels (C). Fully tighten all bolts (J).

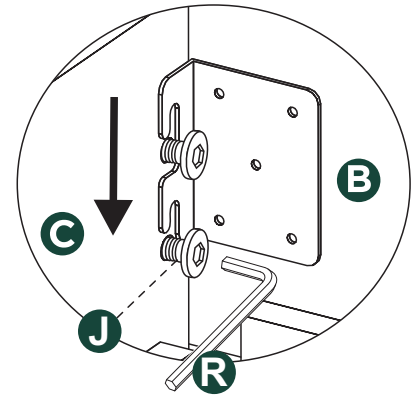
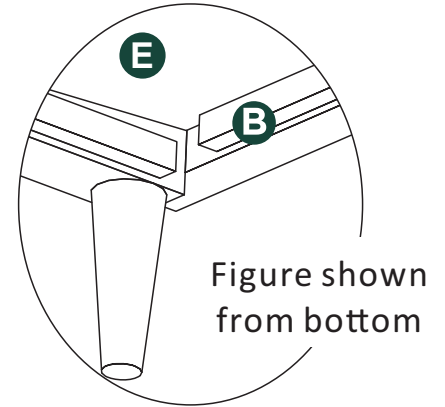
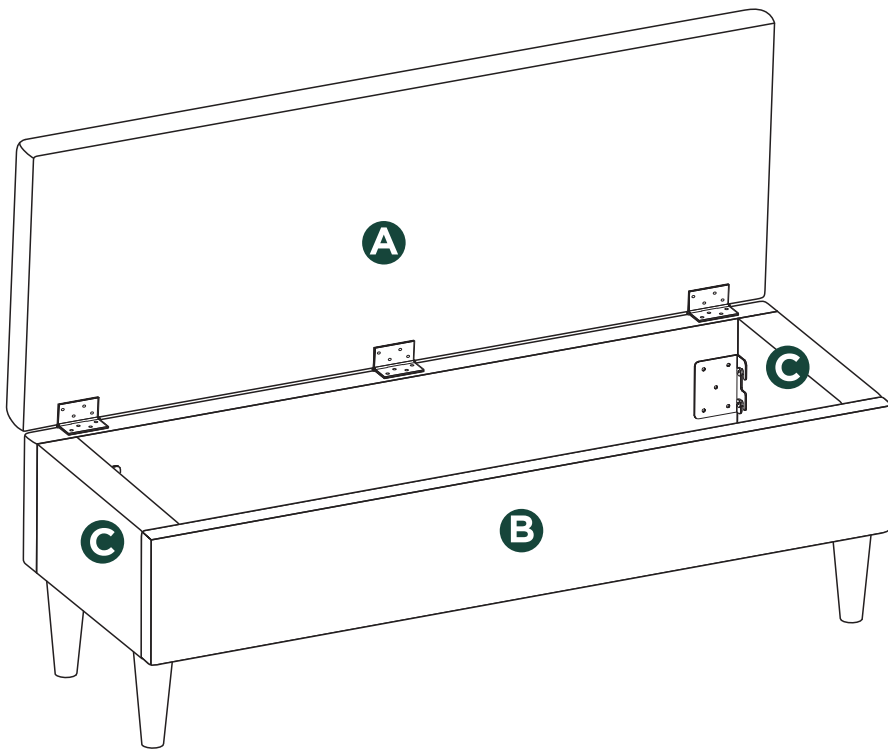

- 6** Fasten the fabric belt into the bolts (K) in both end panels (C).

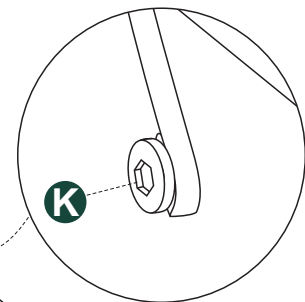
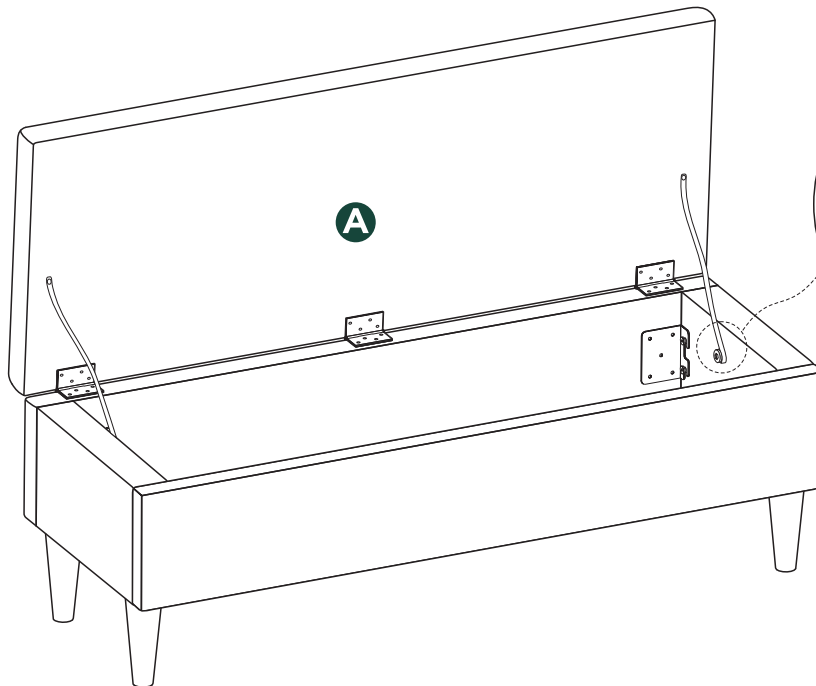

You're all finished!