

Assembly Instructions

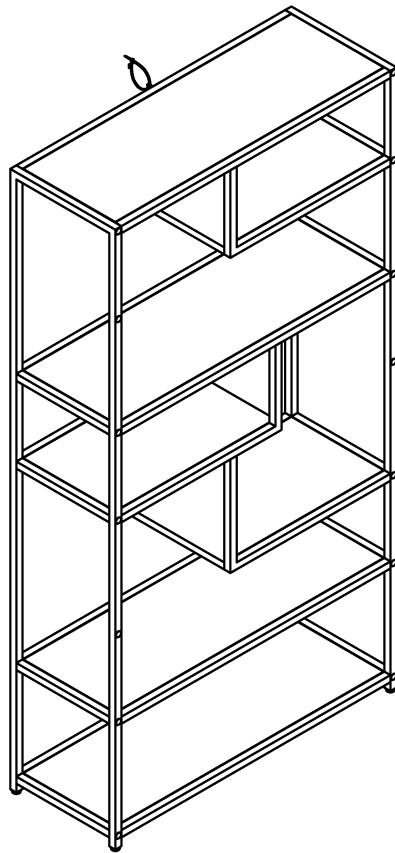

ASSEMBLY RATING

The Assembly Rating is a 5-point system that shows the degree of effort needed in assembling a specific product (with 1 being easy and 5 being difficult). For some products, two persons are recommended.

EASY



DIFFICULT

Tools Required For Assembly:

Allen Wrench

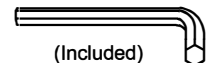

(Included)

Phillips Screwdriver



(Not Included)



2 PERSONS RECOMMENDED

ASSEMBLY & CARE ADVICE

FOR YOUR FURNITURE TO LAST, CORRECT ASSEMBLY AND PROPER MAINTENANCE ARE NECESSARY. PLEASE FOLLOW THE INFORMATION PROVIDED BELOW TO FULLY ENJOY YOUR FURNITURE.

BASIC ASSEMBLY TECHNIQUES



When lock or spring washer is used in an assembly, please make sure the lock or spring washer is placed between the larger flat washer and the head of the screw or bolt.



Position each part correctly and insert screws or bolts into their respective holes by hand tighten or using the proper hand tool. Only tighten when step is completed or when instructed to do so.



Use cardboard or carpet area when assembling furniture to prevent scratches. Make sure the furniture rests on a flat and level surface with each leg evenly touching the floor.



Some furniture comes with height adjustment knobs underneath each leg. To lower or to raise each leg, you need to turn clockwise or counterclockwise, respectively.



Make sure all parts are properly aligned, then use the appropriate hand tool to completely tighten the bolts or screws. Do not use power tools and do not overtighten.



Save the instructions and store the Allen wrench or any supplied tool for later maintenance. After two weeks, check and tighten any loose hardware and repeat again every six months thereafter.

IT IS THE USER'S RESPONSIBILITY TO MAINTAIN THE FURNITURE. THE HARDWARE MAY LOOSEN OVER TIME AND MAY CAUSE THE FURNITURE TO BE WOBBLY AND UNABLE TO SUPPORT ITS INTENDED WEIGHT CAPACITY. THIS MAY LEAD TO COLLAPSE AND MAY CAUSE SERIOUS INJURY.



FAILURE TO FOLLOW THE GUIDELINES ABOVE MAY RESULT IN INJURY AND/OR PROPERTY DAMAGE.

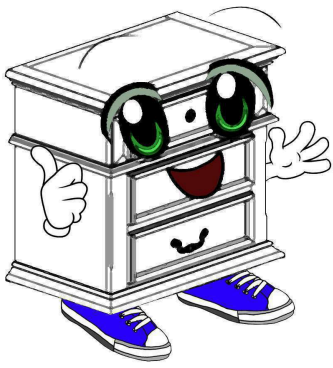

Before you begin, please read Page 2 of "Assembly and Care Advice".

And remember, do not tighten until each step is completed or instructed.

Parts List

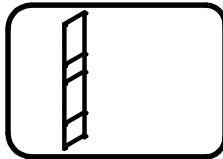
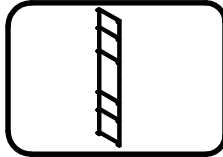
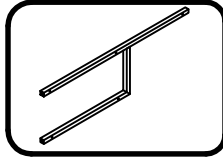
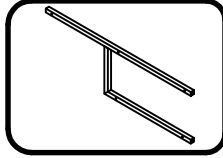
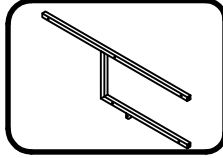
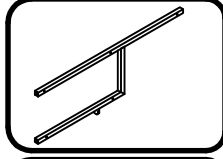
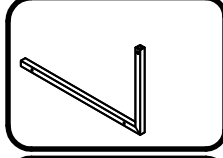
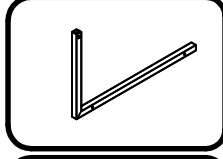
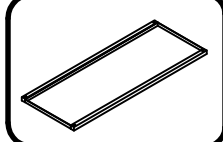
-  #1 x 1pc
Left Panel
-  #2 x 1pc
Right Panel
-  #3 x 1pc
Upper Front Rail
-  #4 x 1pc
Upper Back Rail
-  #5 x 1pc
Middle Front Rail
-  #6 x 1pc
Middle Back Rail
-  #7 x 1pc
Bottom Front Rail
-  #8 x 1pc
Bottom Back Rail
-  #9 x 2pcs
Panel 1

Parts List

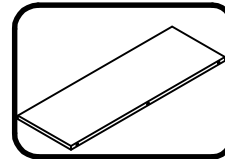
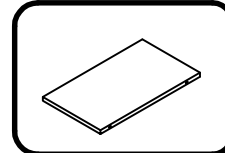
-  #10 x 2pcs
Panel 2
-  #11 x 3pcs
Short Panel

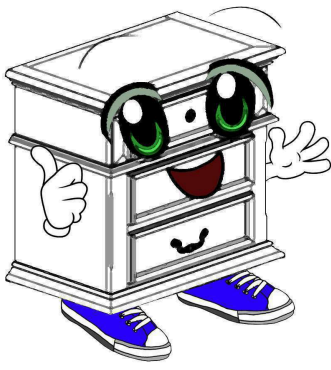

Before you begin, please read Page 2 of "Assembly and Care Advice".

And remember, do not tighten until each step is completed or instructed.

Hardware List

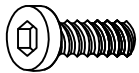

#A x 24pcs
Bolt ϕ 1/4"x1/2"

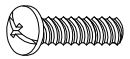

#B x 24pcs
Bolt ϕ 3/16"x1/2"

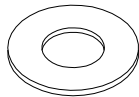

#C x 24pcs
Metal Washer

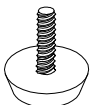

#D x 4pcs
Leveler 1/4"X23mm



#E x 1pc
Bolt M4x16mm



#F x 1pc
Bolt M4x50mm



#G x 2pcs
Metal Bracket





#H x 1pc
Zip Plastic Tie



#I x 1pc
Allen Wrench



ASSEMBLY Do not fully tighten all bolts until assembly is complete. This will help all parts to assemble properly.

- #A  4pcs
- #C  4pcs
- #I 

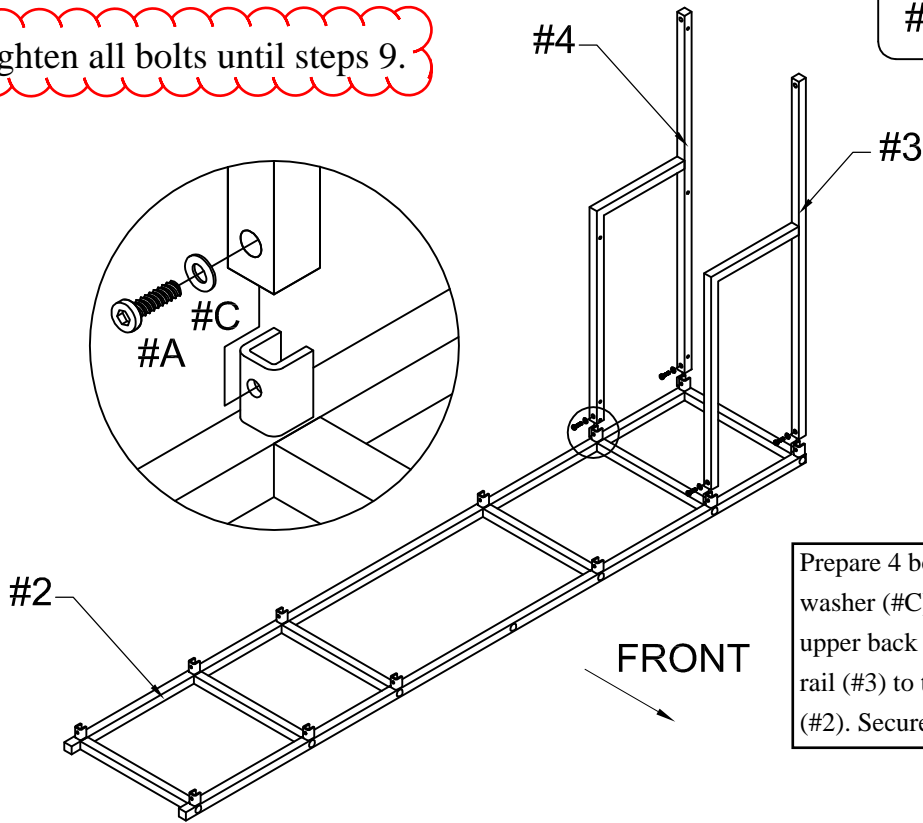

Do not fully tighten all bolts until steps 9.



Prepare 4 bolts assembly by inserting washer (#C) onto bolts (#A). Align upper back rails (#4) and upper front rail (#3) to the holes of the right panel (#2). Secure with bolts (#A).



FRONT

- #A  2pcs
- #C  2pcs
- #I 

1) Prepare 2 bolts assembly by inserting washer (#C) onto bolts (#A). Align middle front rail (#5) to the hole of the bottom front rail (#7), then secure with bolts (#A).

2) Align middle back rails (#6) to the hole of the bottom back rail (#8), then secure with bolts (#A).

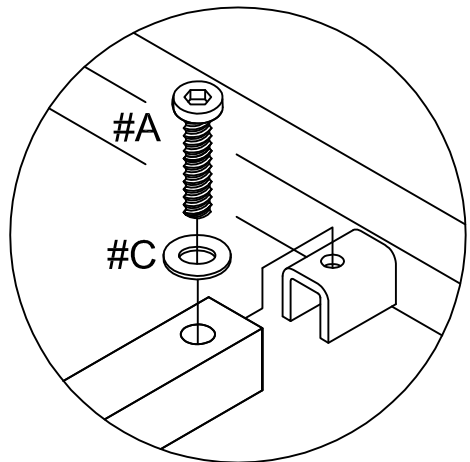
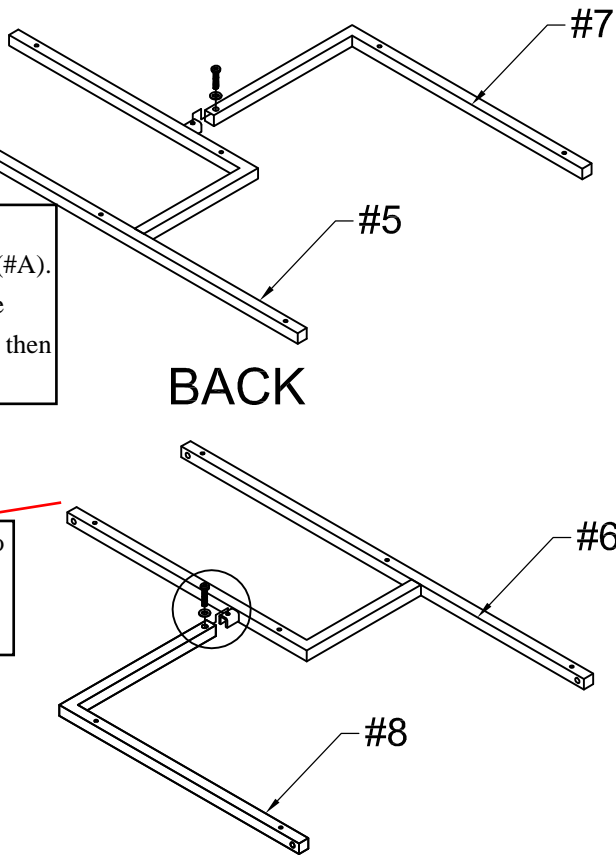



#3

2) Align middle and bottom back rails to the holes facing back of the right panel (#2).

#A  4pcs

#C  4pcs

#I 

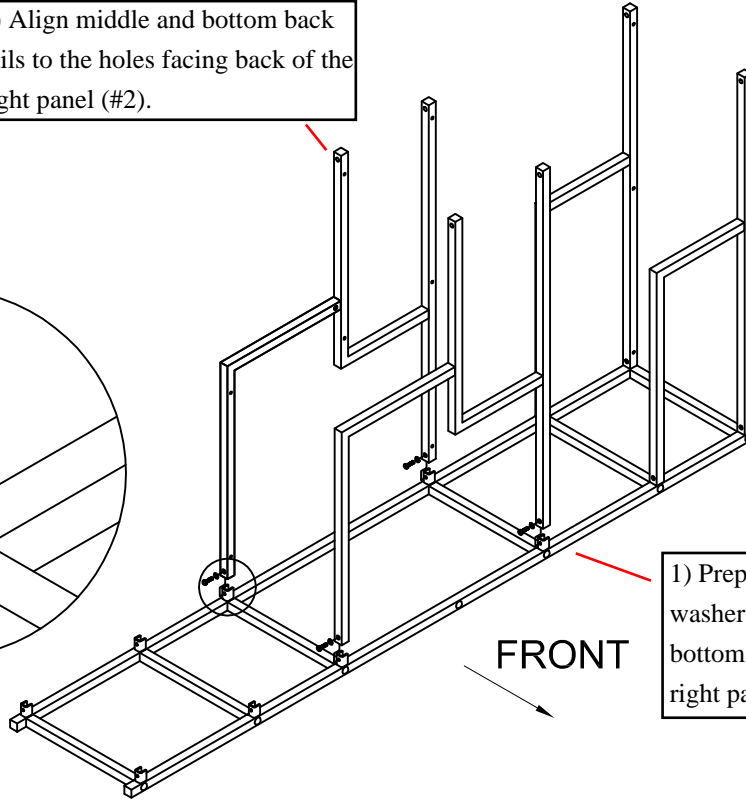
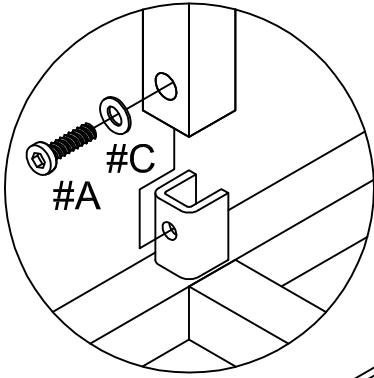

1) Prepare 4 bolts assembly by inserting washer (#C) onto boles (#A). Align middle and bottom front rails to the holes facing front of right panel (#2).



#4

Prepare 2 bolts assembly by inserting washer (#C) onto bolts (#A). Align panel 1 (#9) to the holes of the right panel, then secure with bolts (#A).

#A  2pcs

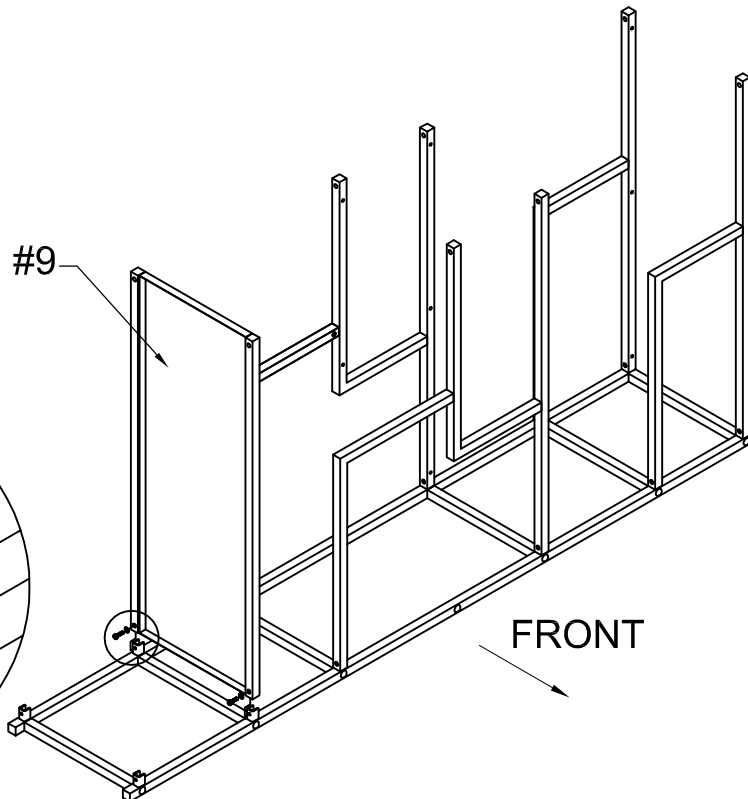
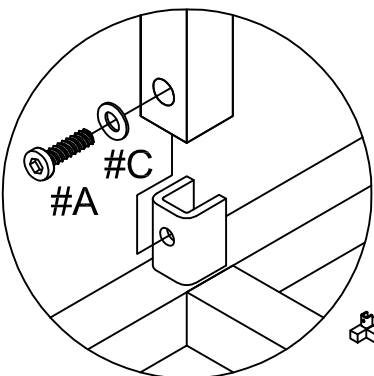

#C  2pcs

#I 





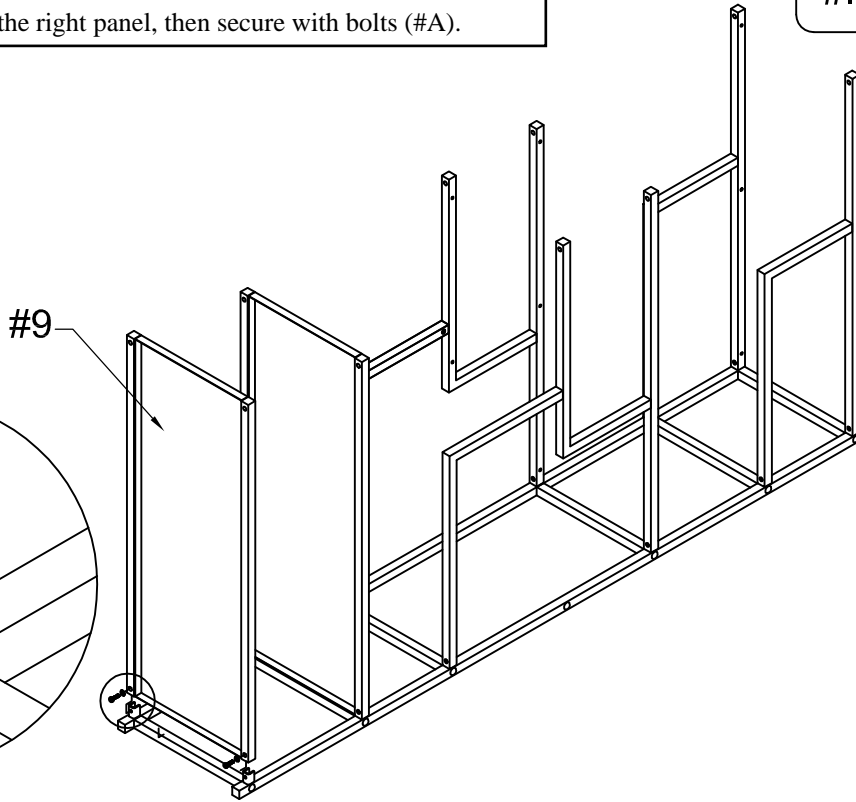
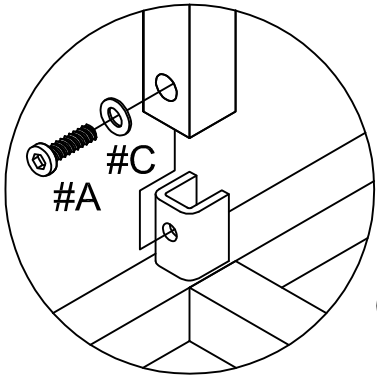

Prepare 2 bolts assembly by inserting washer (#C) onto bolts (#A). Align panel 1 (#9) to the holes of the right panel, then secure with bolts (#A).

- #A  2pcs
- #C  2pcs
- #I 



Prepare 10 bolts assembly by inserting washer (#C) onto bolts (#A). Align left panel (#1) to the rest of the shelf and secure with bolts (#A).

- #A  10pcs
- #C  10pcs
- #I 

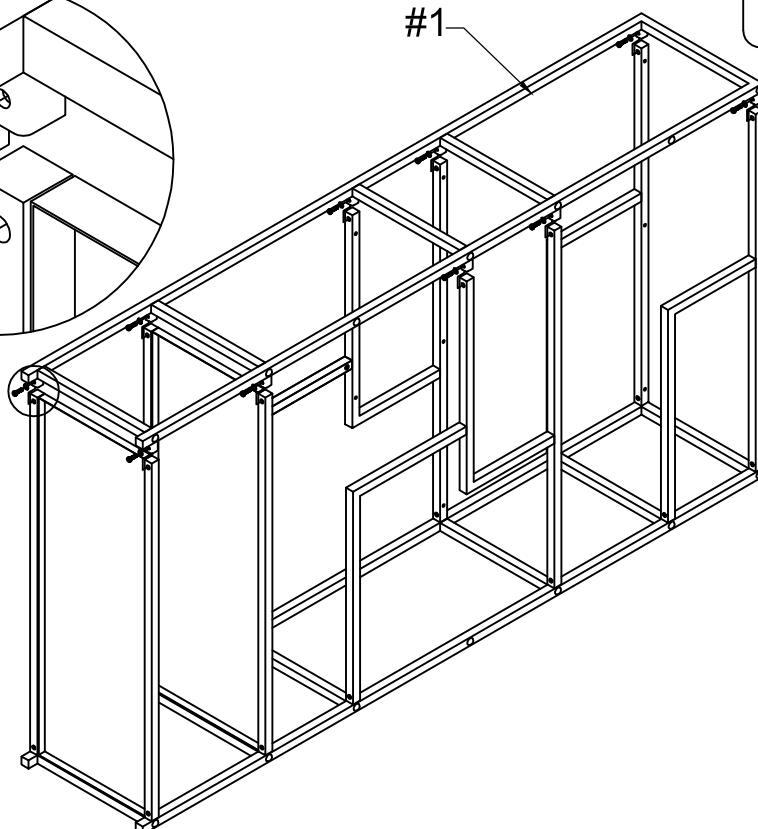
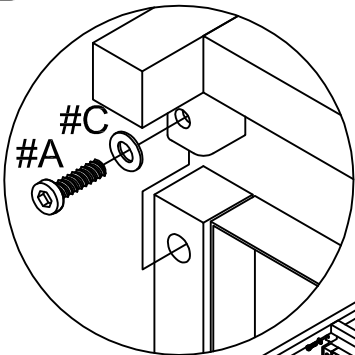



#7

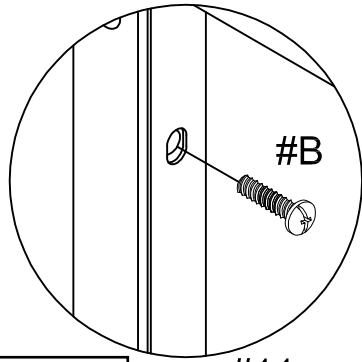

#B

#B  12pcs

Align short panels (#11) to the holes of the shelves as shown in the picture. Secure with bolts (#B).

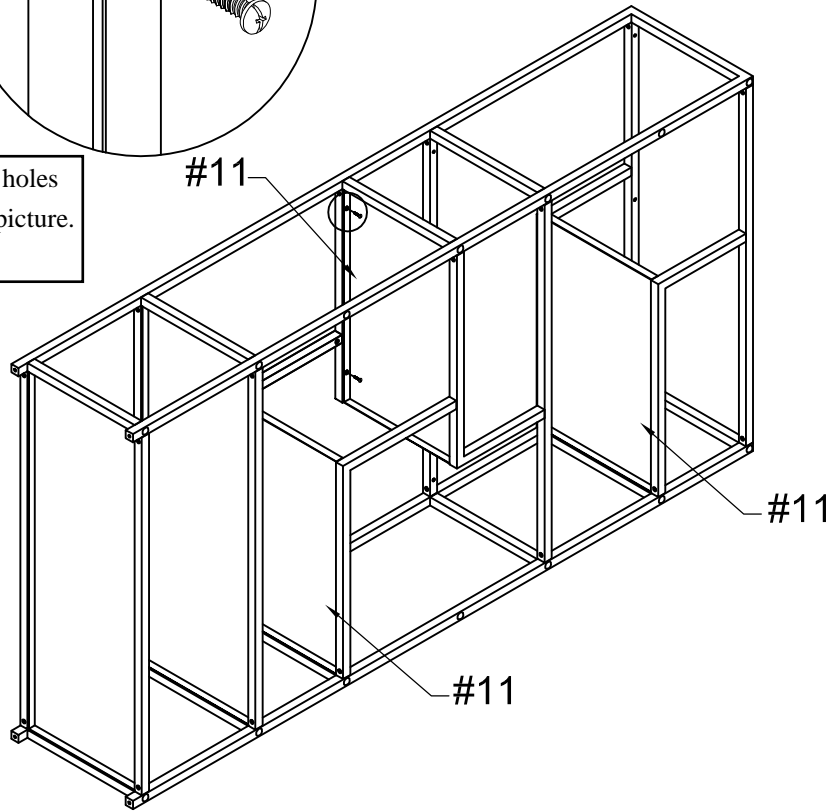

#8

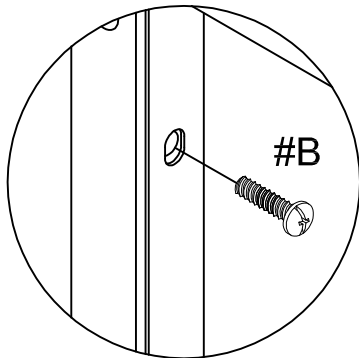

#B

#B  12pcs

Align long panels (#10) to the shelves, then secure with bolts (#B).

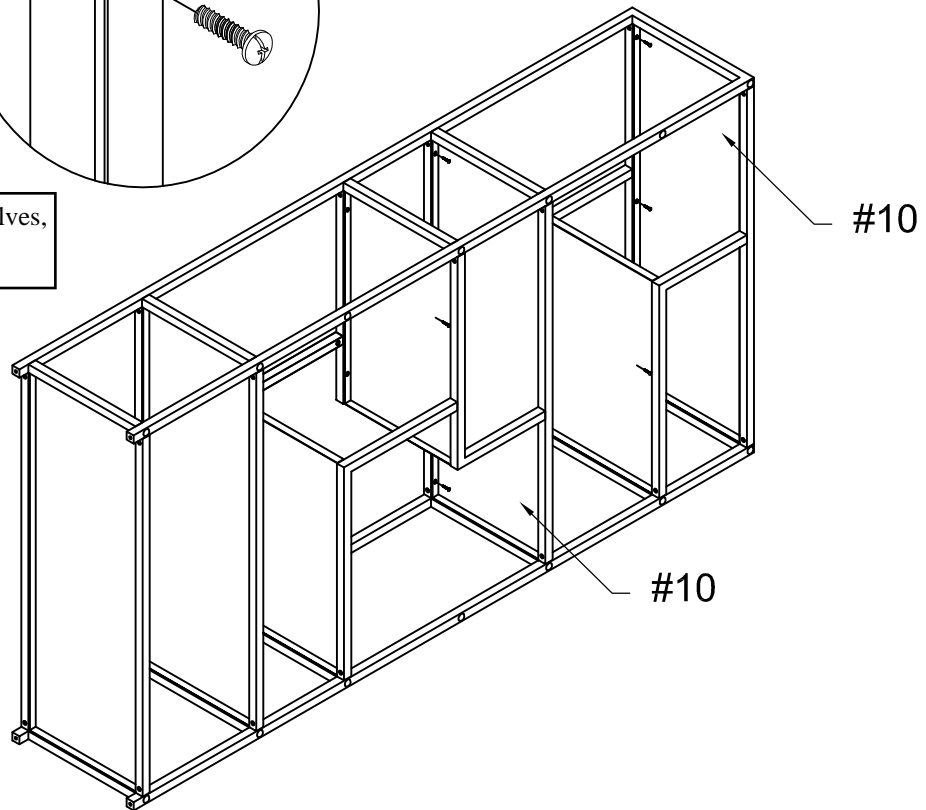



Attach and adjust adjustable floor protectors according to ground level.

#D



4pcs

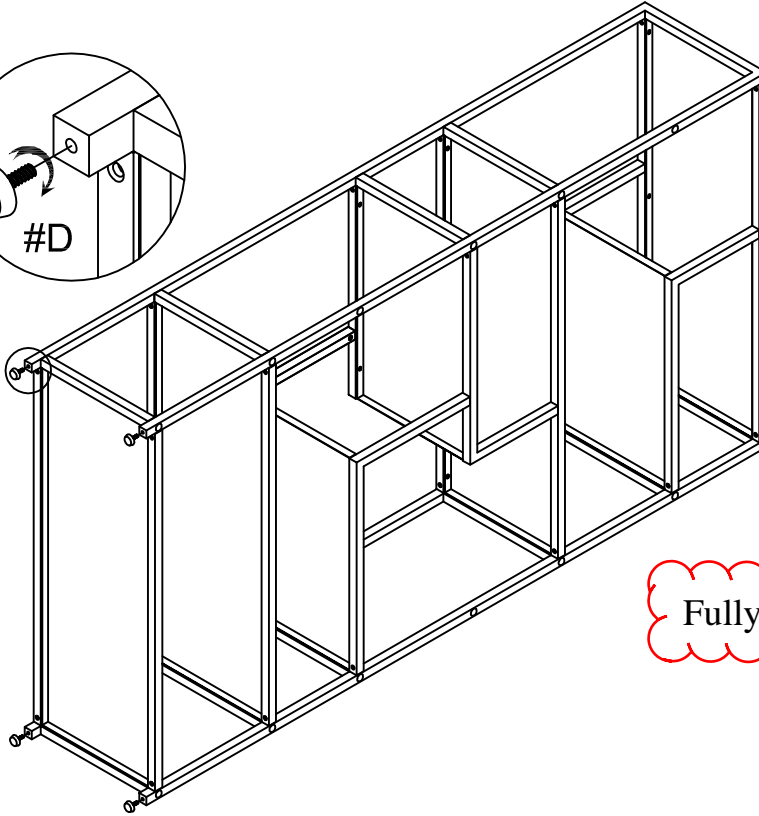
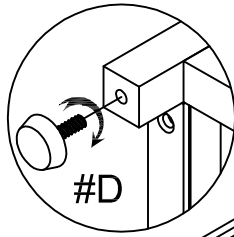

Fully tighten all bolts



Tipping restraint optional.

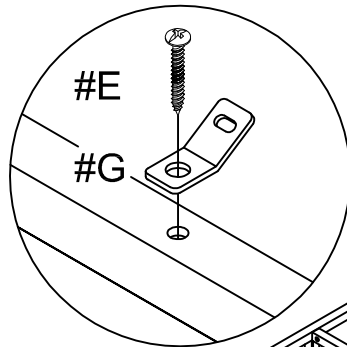

#E



1pc

#G



1pc

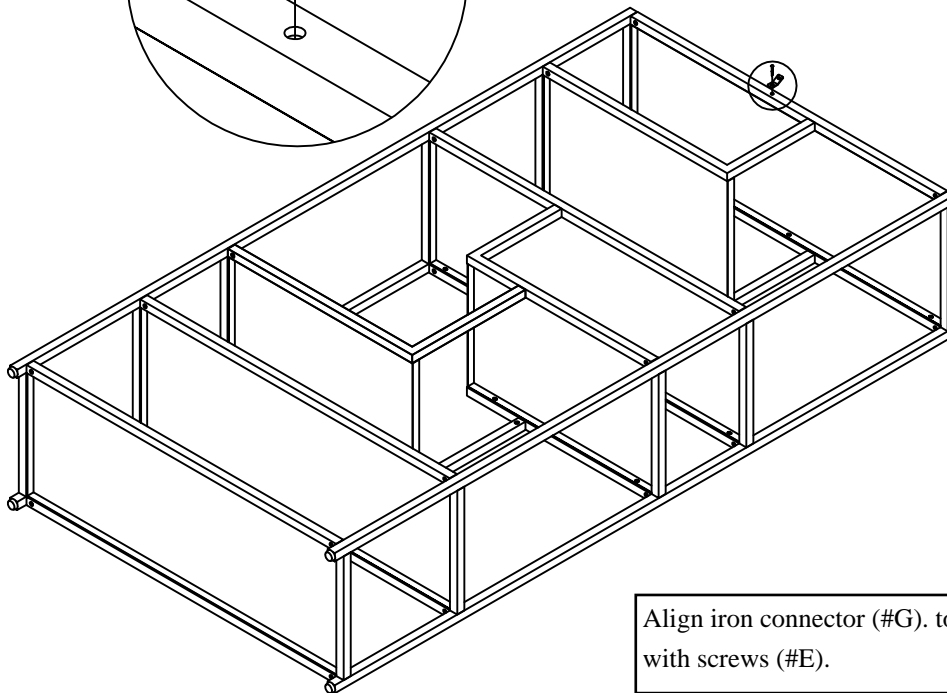



Align iron connector (#G) to top of shelf, then secure with screws (#E).

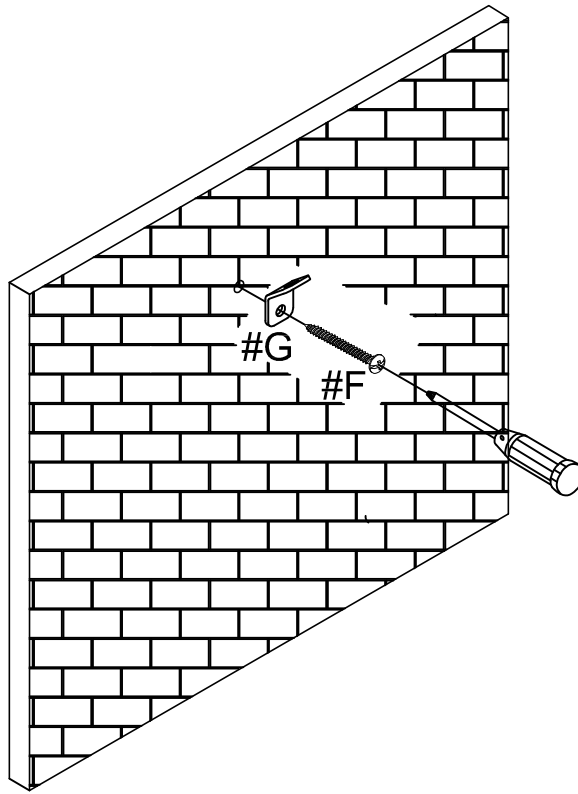

Create your own hole and screw iron connector (#G) to the wall with screws (#F).



- #F  1pc
- #G  1pc



- #H  1pc

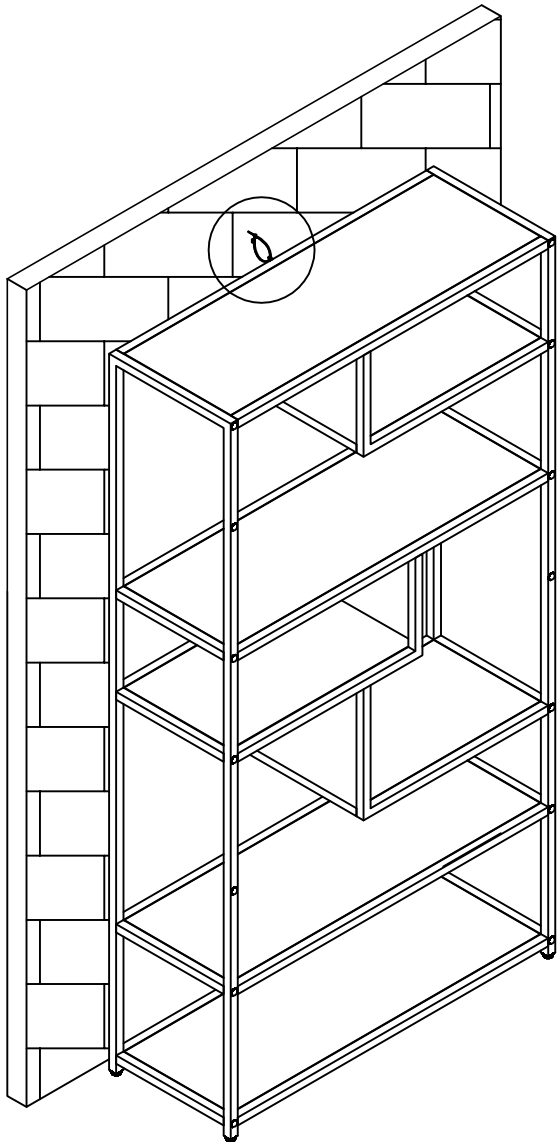

TO PREVENT TIP OVER
PRODUCT MUST BE
ATTACHED TO WALL

