

# Assembly Manual

## Bar Chair

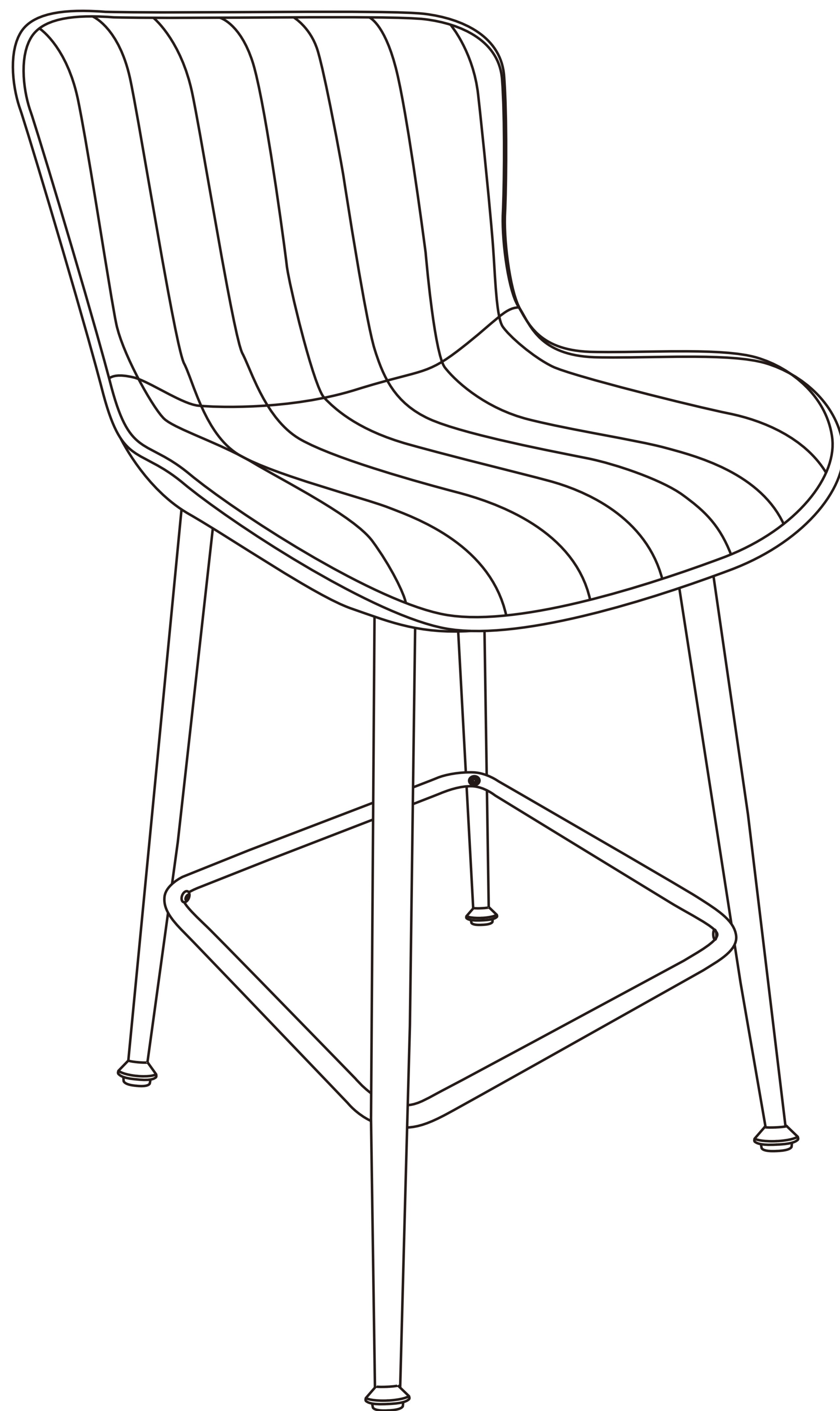

Please read this manual carefully before any operation and keep it properly for future use.

# Exploded View

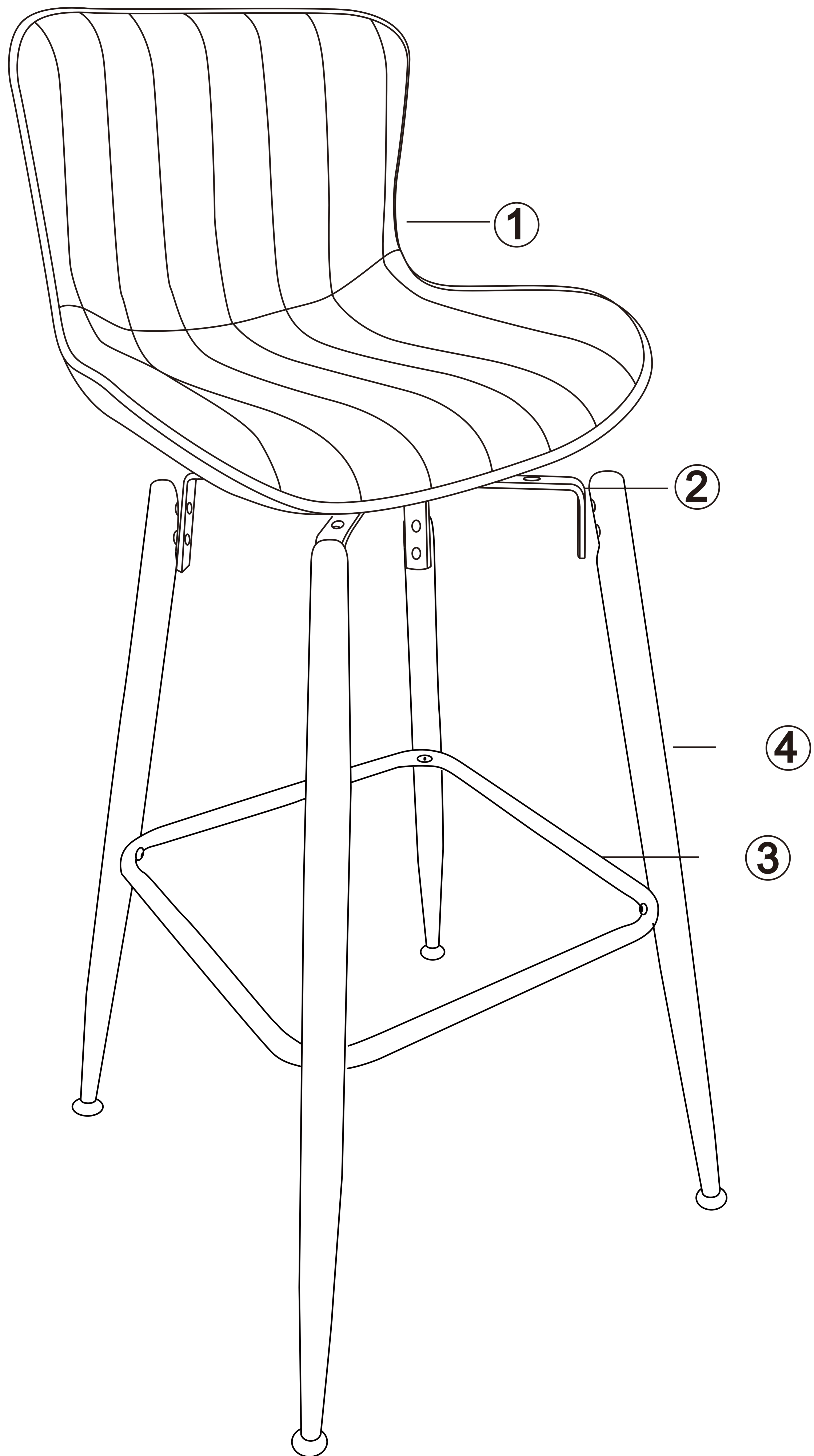

# Components List

10 min

Assembly Time

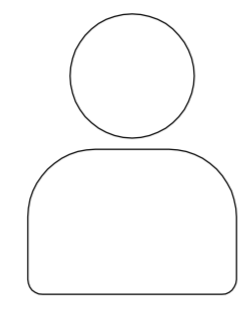

One People

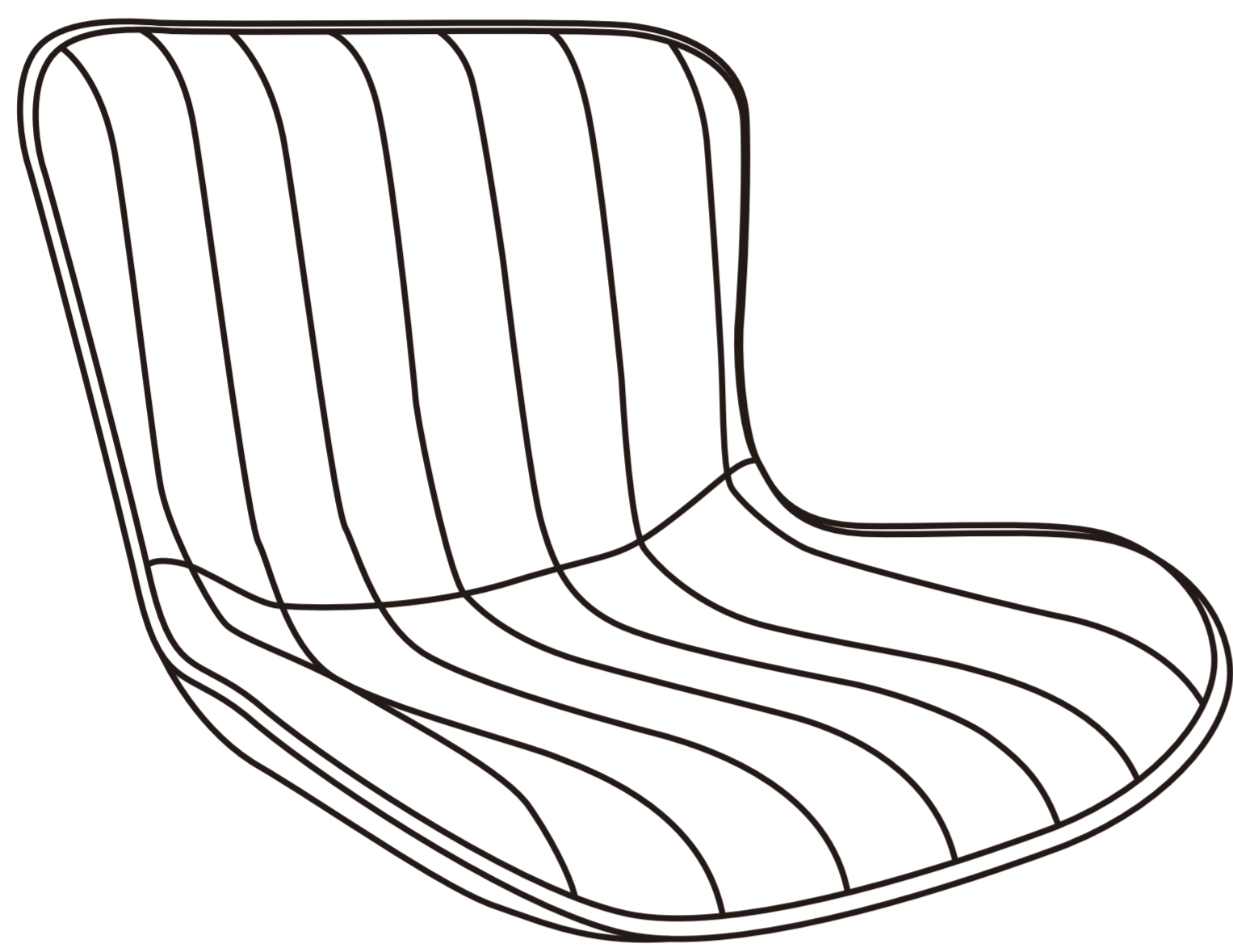

1

**Seat** (X1)

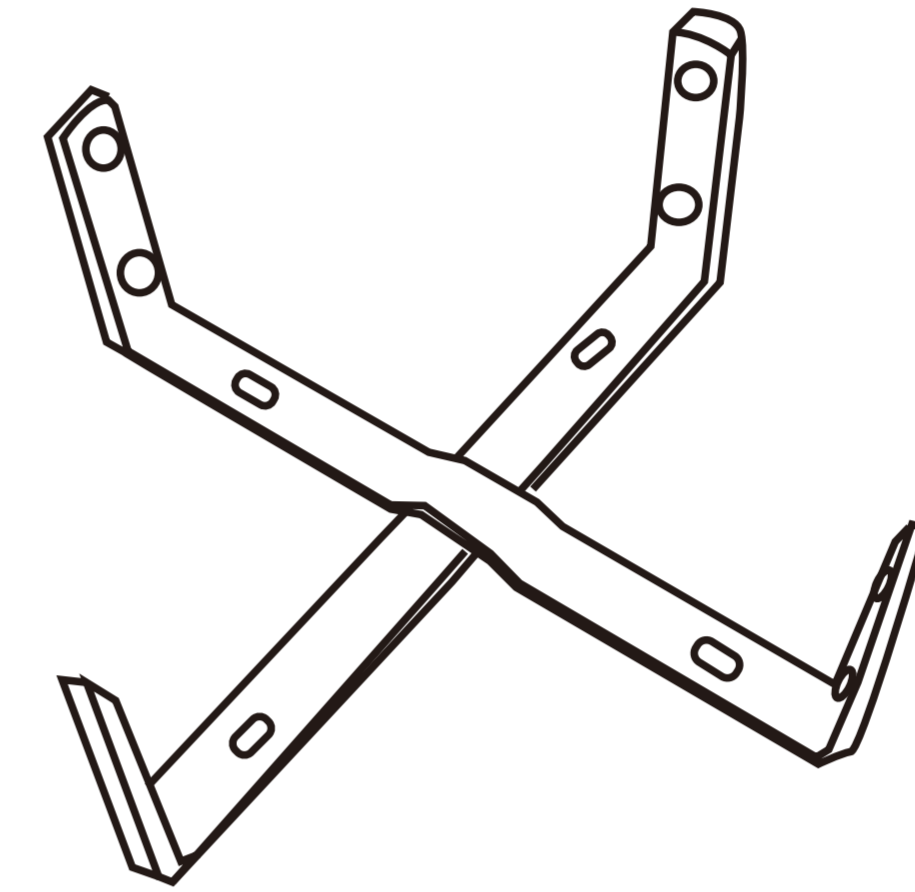

2

**Metal cross** (X1)

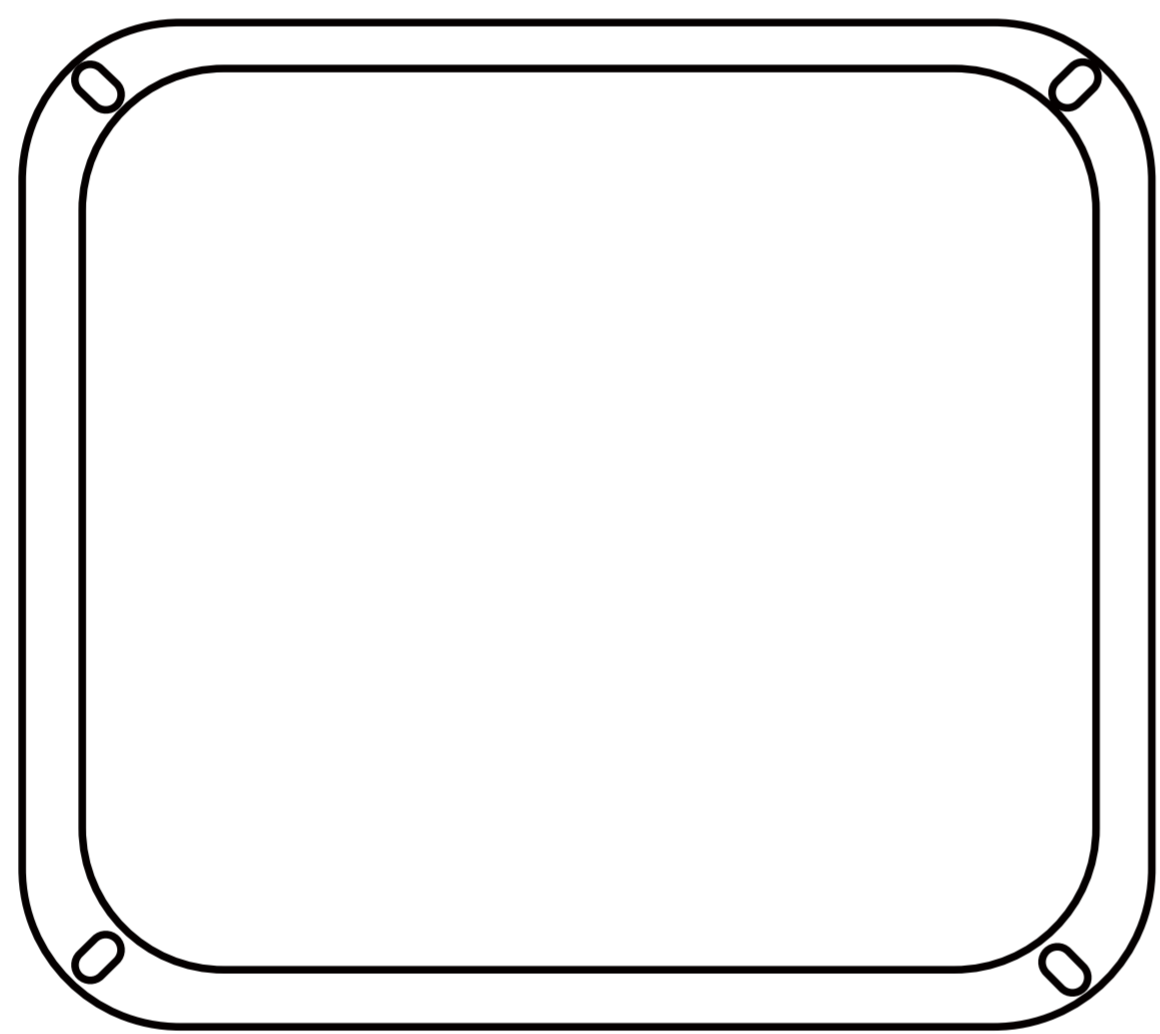

3

**Footrest** (X1)

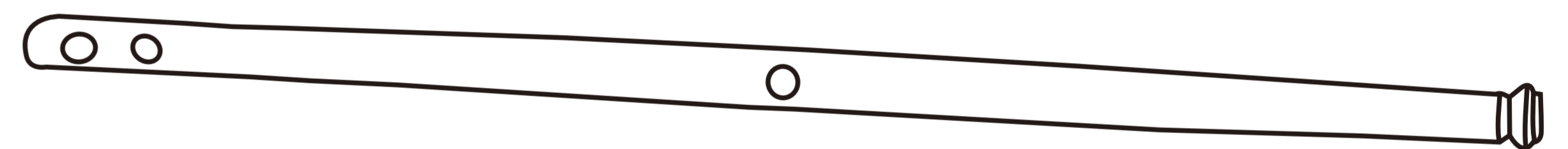

4

**Metal legs** (X4)

# Components list

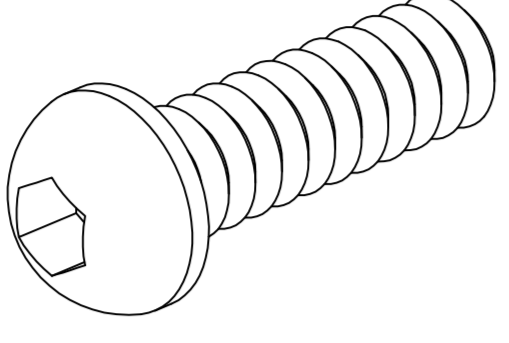
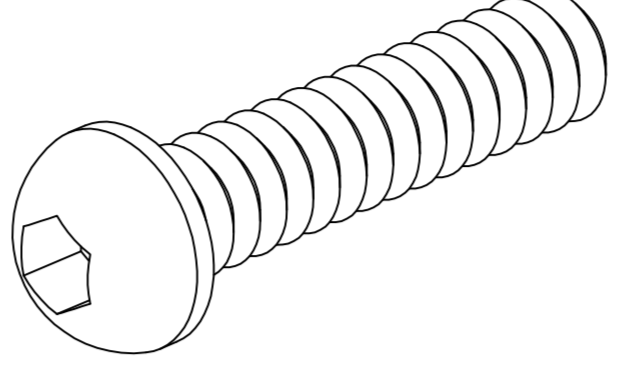
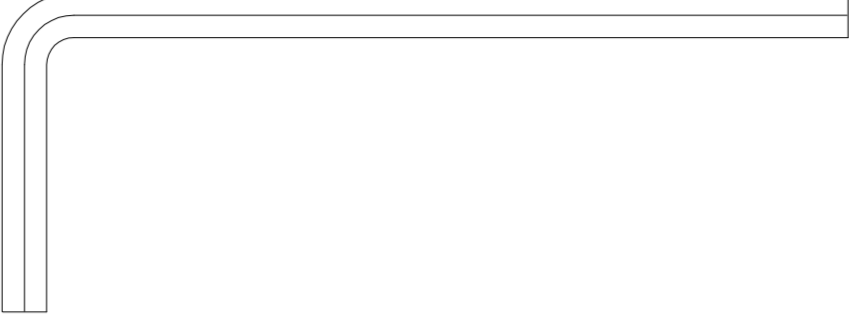
A			B			C		
								
Bolt	M6x20	12+2	Bolt	M6x25	4+1	Allen wrench		1

**Note:**The number after “+” sign indicates the extra piece(s).

# Assembly Instruction

## STEP 1

Attach the metal cross(2) to the metal legs (4) using bolts(A) and Allen wrench(C). Tighten all the screws 70% so that you can adjust slightly during the process of assembly.

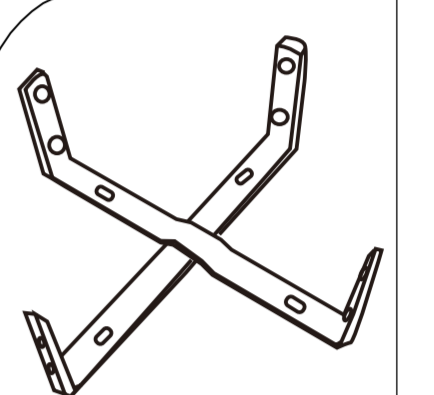
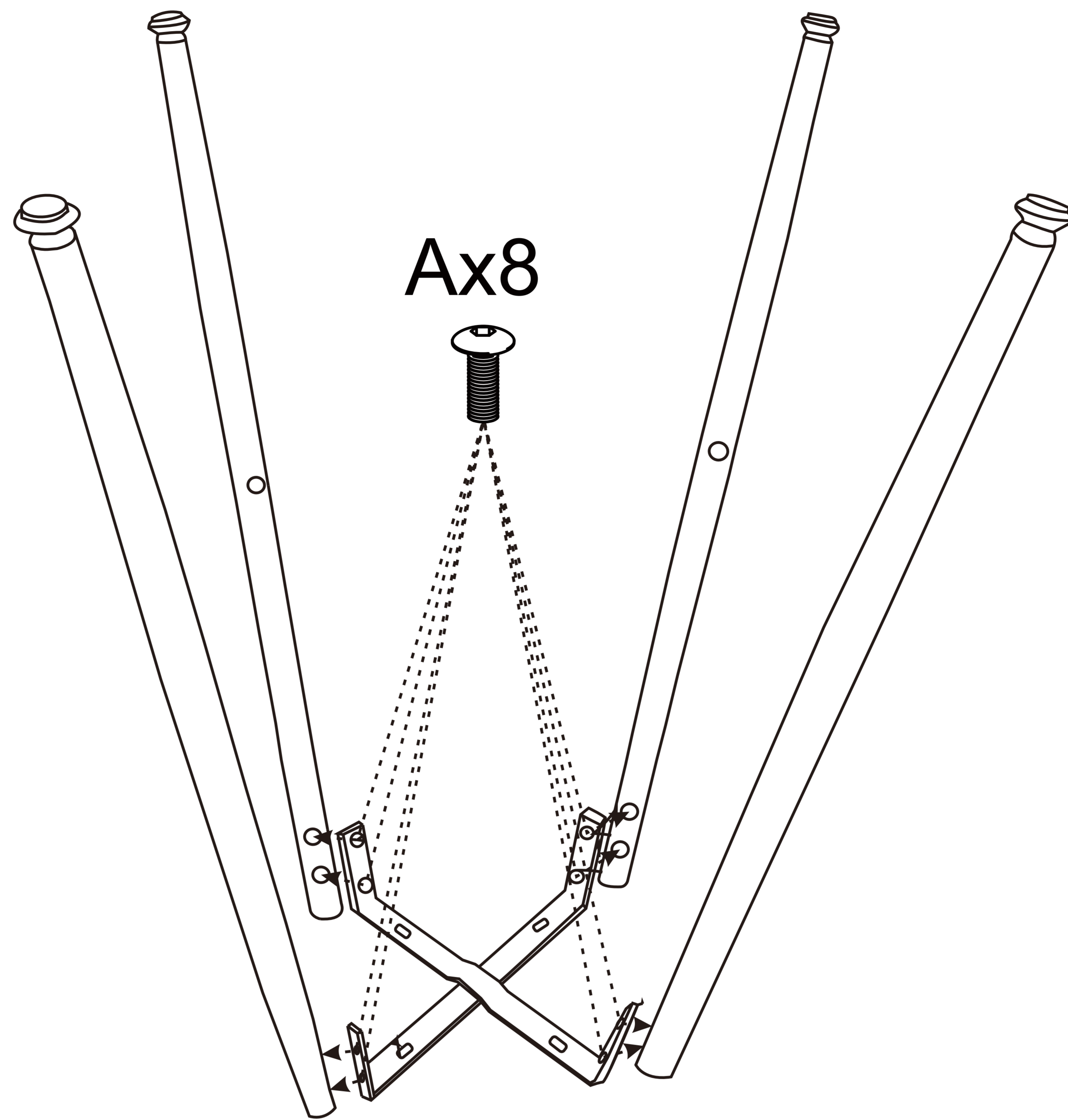

2\*1

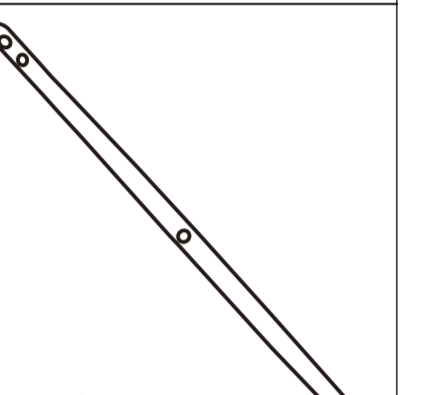

4\*4

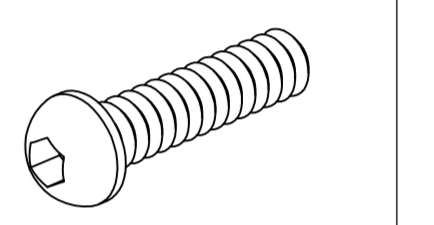

A\*8



C\*1

## STEP 2

Attach the footrest(3) to the metal legs (4) using bolts(B) and Allen wrench(C). Tighten all the screws 70% so that you can adjust slightly during the process of assembly.

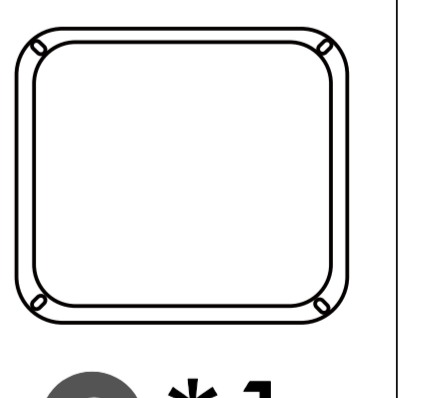
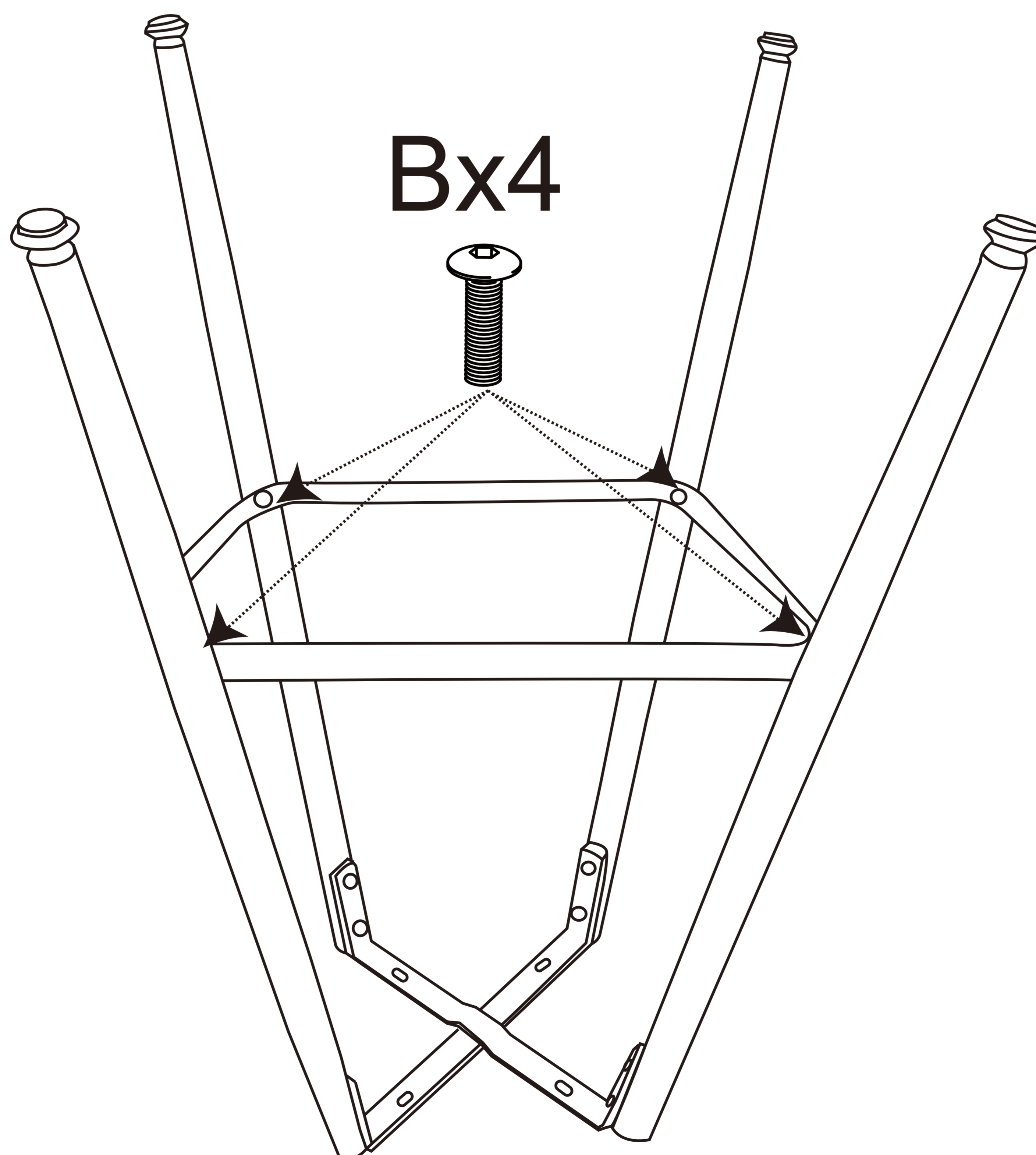

3\*1

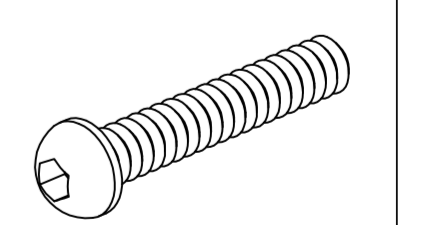

B\*4



C\*1

# Assembly Instruction

## STEP 3

Attach the metal cross(2) to the seat (1) using bolts(A) and Allen wrench(C). Tighten all the screws 70% so that you can adjust slightly during the process of assembly.

Ax4

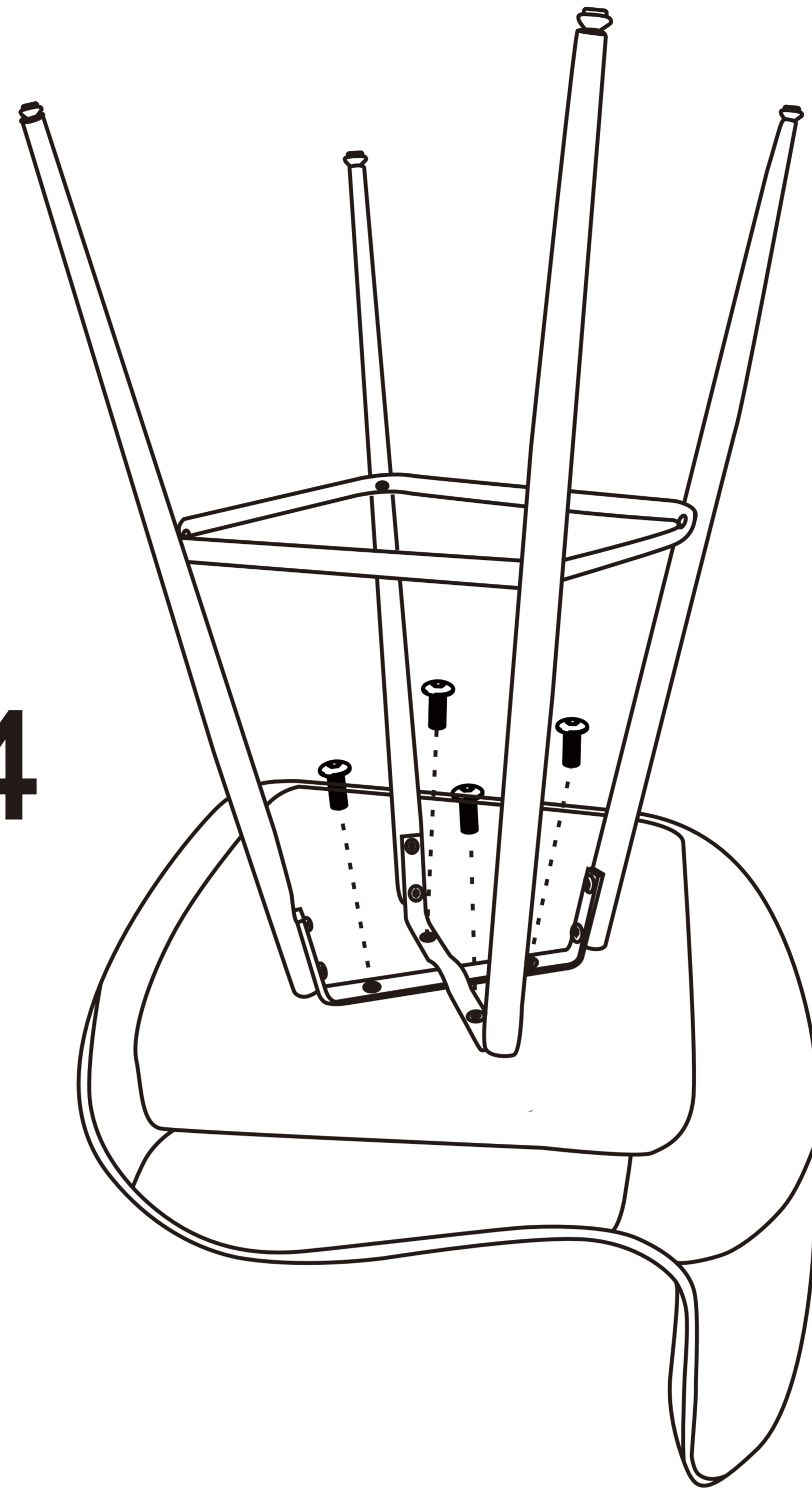

1 \*1

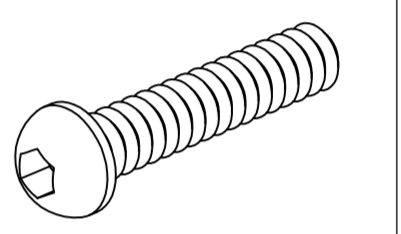

A\*4



C\*1

## STEP 4

Tighten all bolts fully, and turn the assembled seat upright. Assembly completed. If you find the chair not level, please adjust by rotating the feet pads on the legs.

