

ASSEMBLY INSTRUCTIONS / INSTRUCTIONS DE MONTAGE

DINING TABLE / TABLE À MANGER

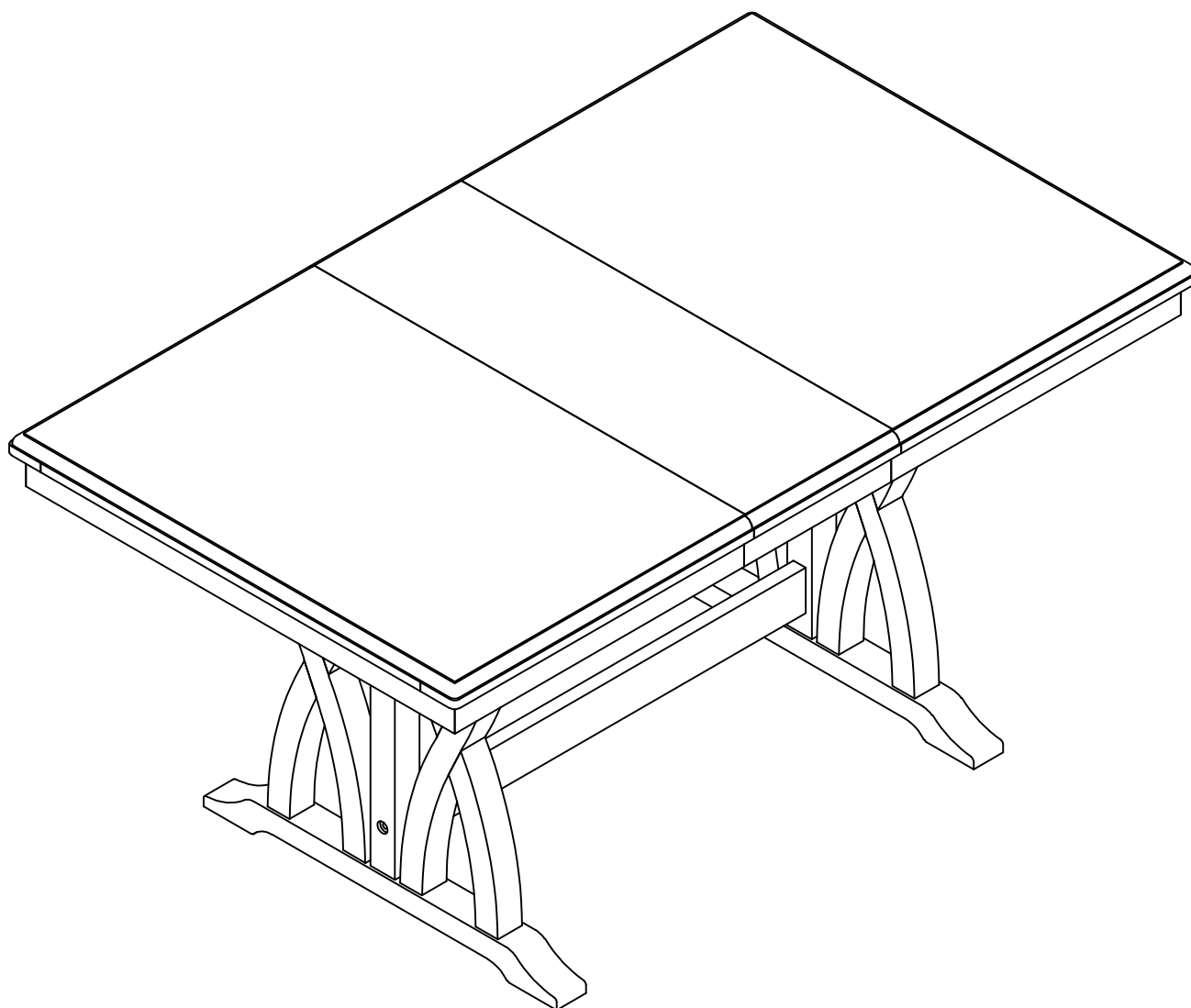



IMPORTANT NOTE :

- ① PLACE ALL PARTS ON A CLEAN AND SMOOTH SURFACE SUCH AS A RUG OR CARPET TO AVOID THE PARTS FROM BEING SCARTCHED .
PLACEZ TOUTES LES PIÈCES SUR UNE SURFACE PROPRE ET LISSE COMME UN TAPIS OU UN CARPET POUR ÉVITER QUE LES PIÈCES SONT ÉCARTÉES.
- ② BEFORE YOU BEGIN , KINDLY FOLLOW THE ASSEMBLY INSTRUCTIONS STEP BY STEP
AVANT DE COMMENCER, VEUILLEZ SUIVRE LES INSTRUCTIONS D'ASSEMBLAGE ÉTAPE PAR ÉTAPE
- ③ DO NOT TIGHTEN ALL SCREWS AND BOLTS UNTIL THE TABLE FULLY SET-UP
NE SERREZ PAS TOUTES LES VIS ET BOULONS TANT QUE LA TABLE N'EST PAS COMPLÈTEMENT INSTALLÉE

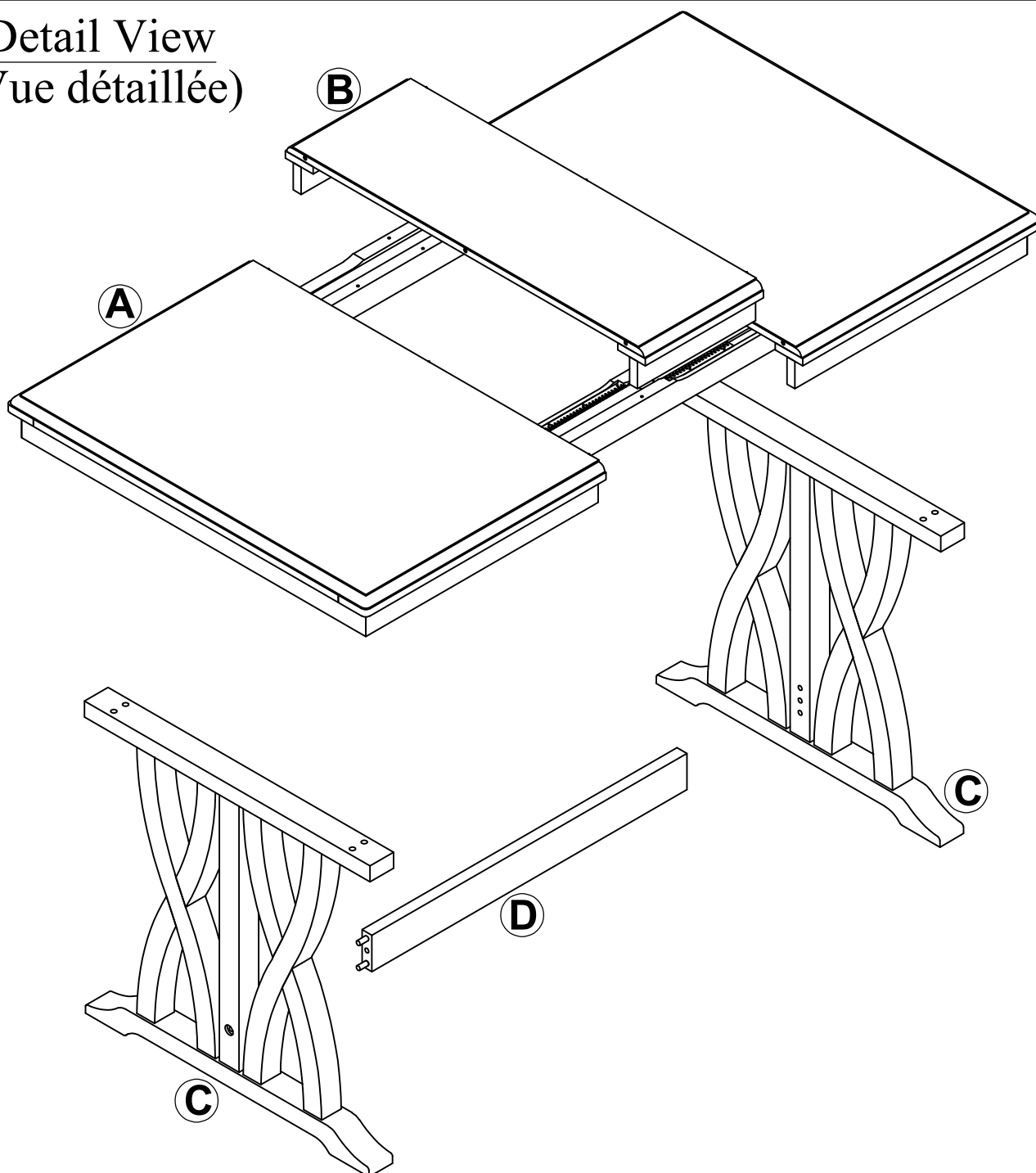

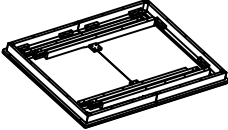
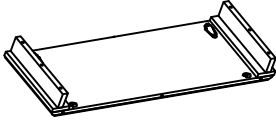
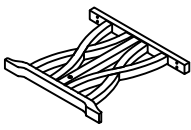

Detail View
(Vue détaillée)

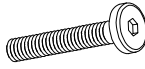
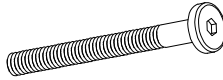

Part List / (Liste des pièces)

<p>A</p>  <p>TOP FRAME =1pc (PLATEAU DE TABLE) =1pc</p>	<p>B</p>  <p>LEAF =1pc (FEUILLE) =1pc</p>	<p>C</p>  <p>LEGS =2pcs (JAMBES) =2pcs</p>
<p>D</p>  <p>MIDDLE STRETCHED =1pc (MILIEU ÉTIRÉ) =1pc</p>		

Hardware List For Table / Liste du matériel pour le tableau

<p>1</p>  <p>Bolt/ Boulon =8pcs 5/16 * 55 mm</p>	<p>2</p>  <p>Bolt/ Boulon =2pcs 5/16 * 70 mm</p>	<p>3</p>  <p>Spring Washer/Rondelle ressort =10pcs 5/16 * 13mm * 1.5 mm</p>
<p>4</p>  <p>Flat Washer/ Rondelle plate =10pcs 5/16 * 19mm * 1.5 mm</p>	<p>5</p>  <p>Allen Key/ Clé Allen =1pc 4mm*60mm</p>	

STEP 1 ÉTAPE 1

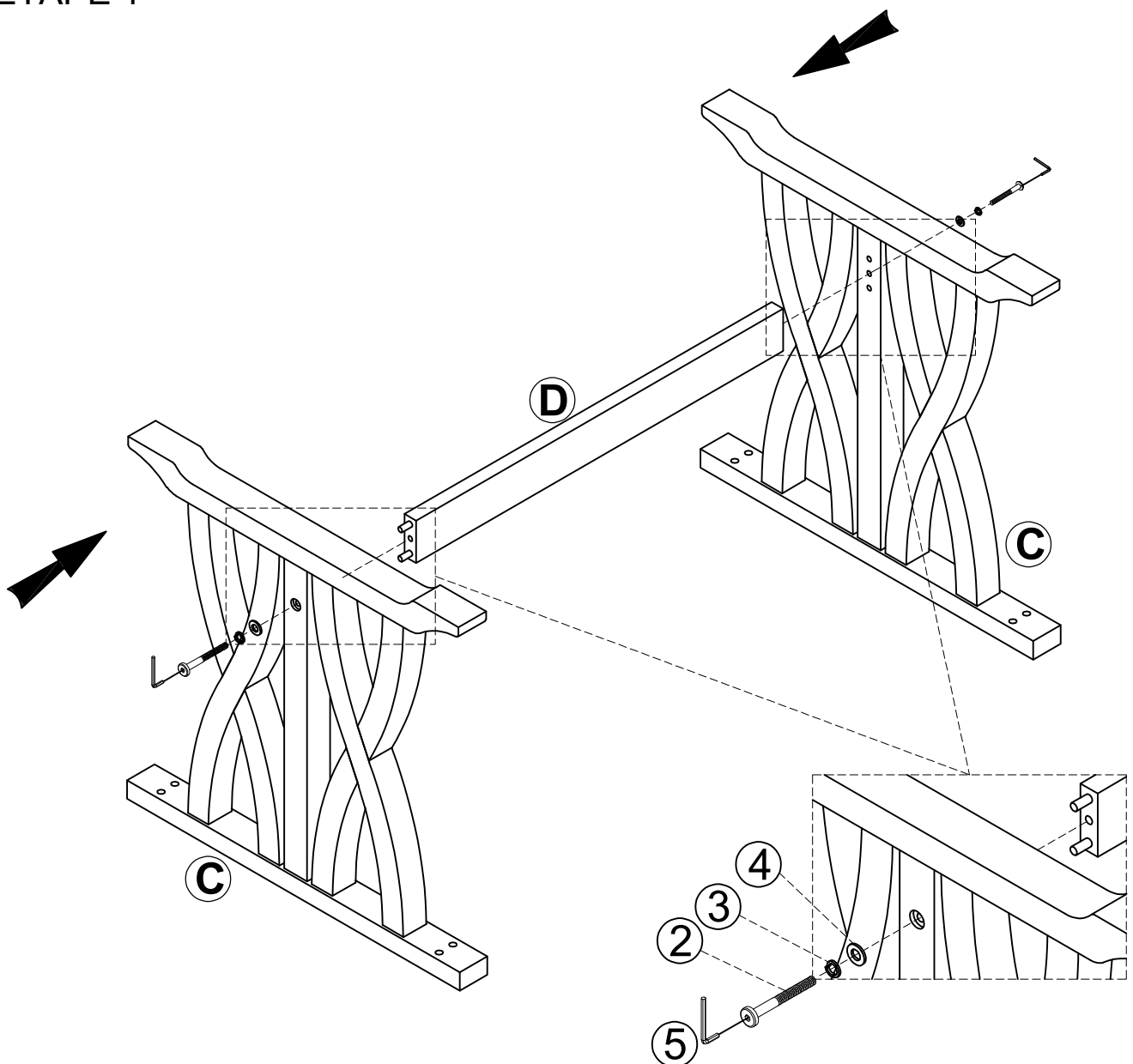

STEP 2
ÉTAPE 2

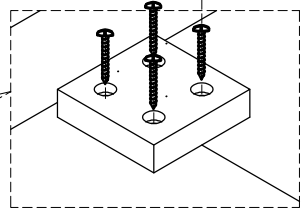
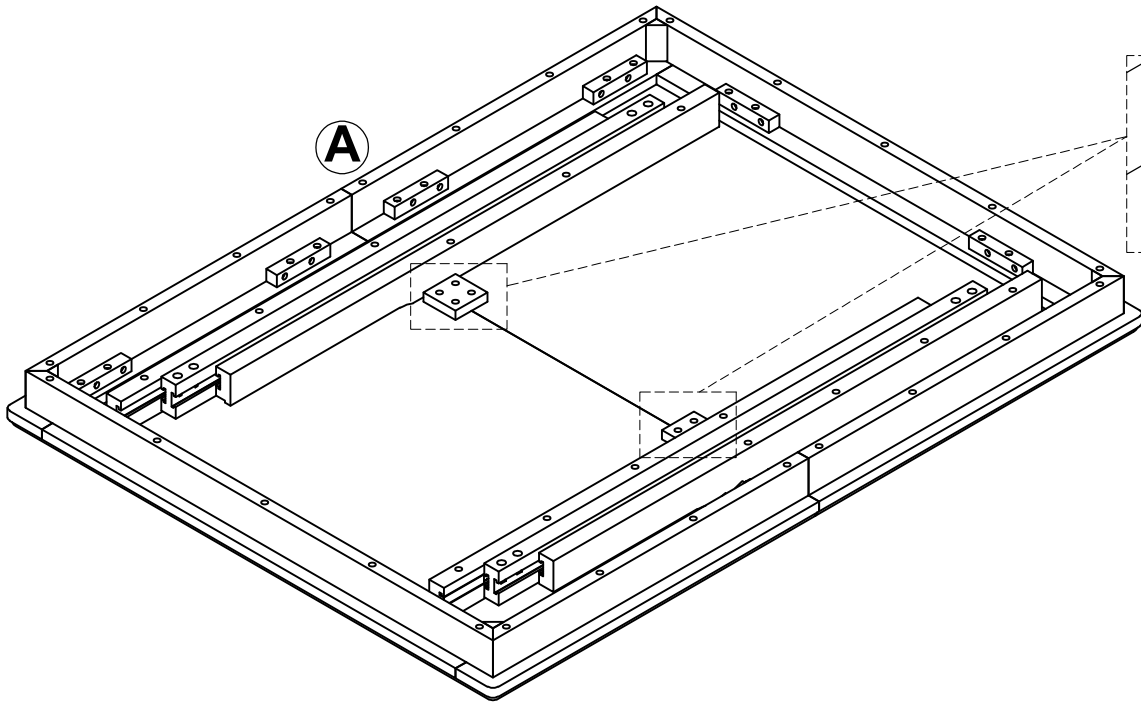

Remove
(retirer)

STEP 3
ÉTAPE 3

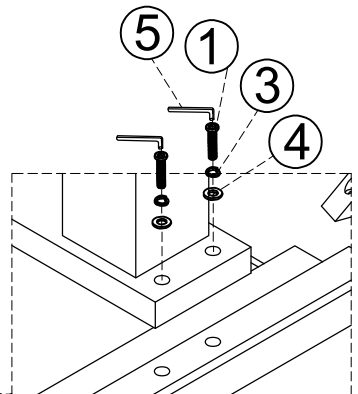
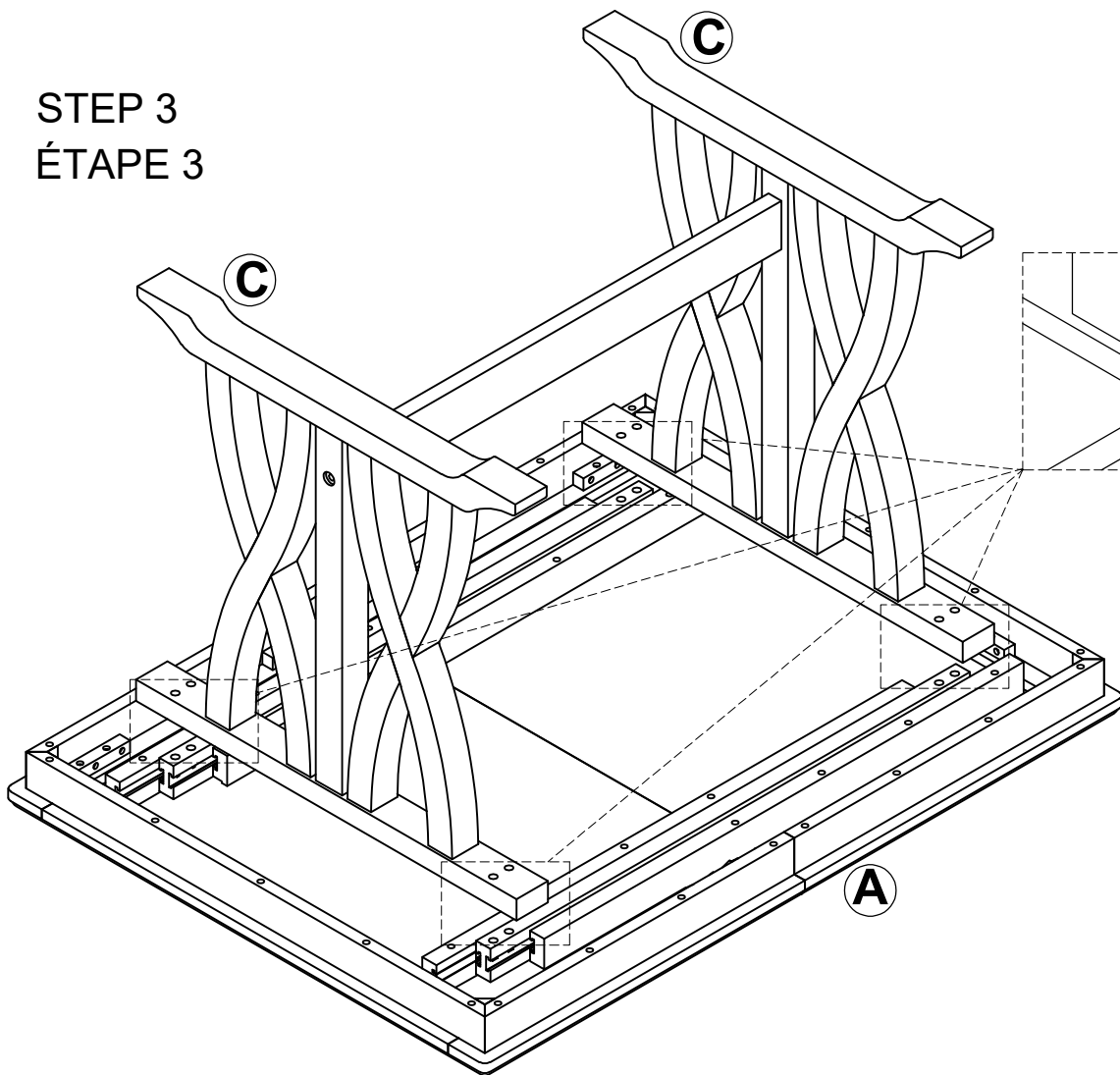

STEP 4
ÉTAPE 4

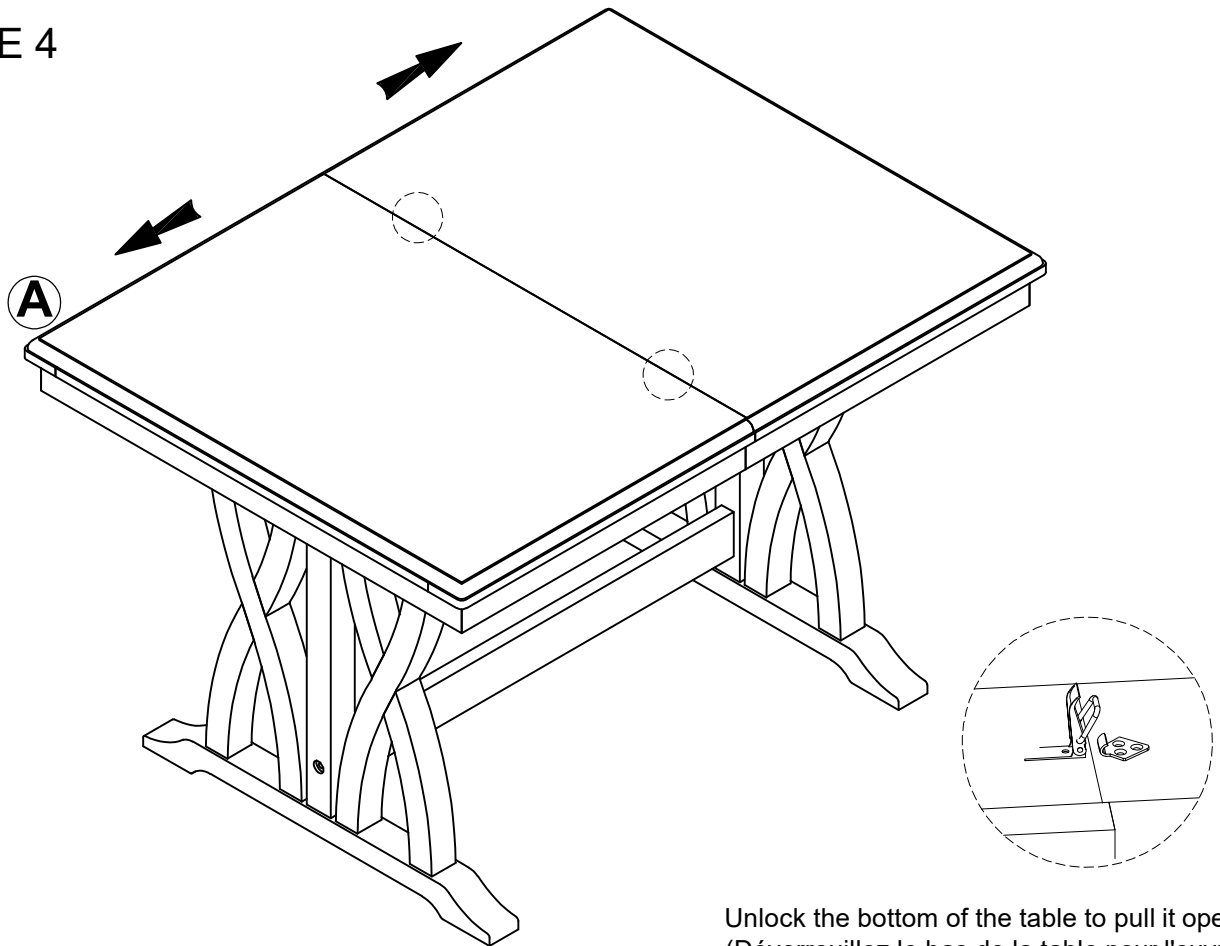

Unlock the bottom of the table to pull it open.
(Déverrouillez le bas de la table pour l'ouvrir.)

STEP 5
ÉTAPE 5

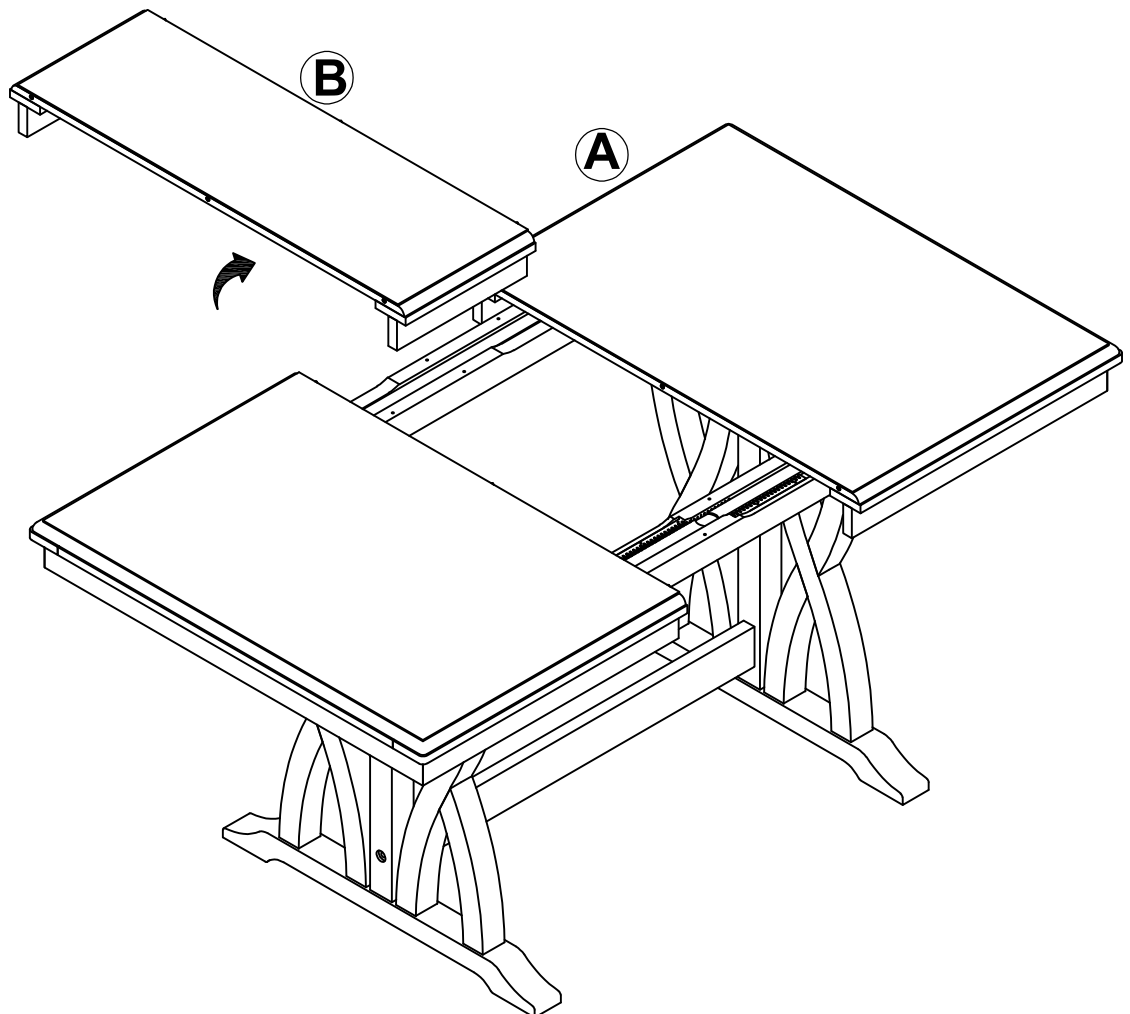

Completed Assembly
Assemblage terminé

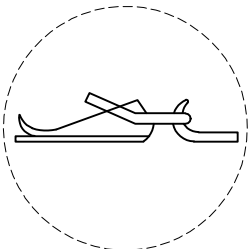
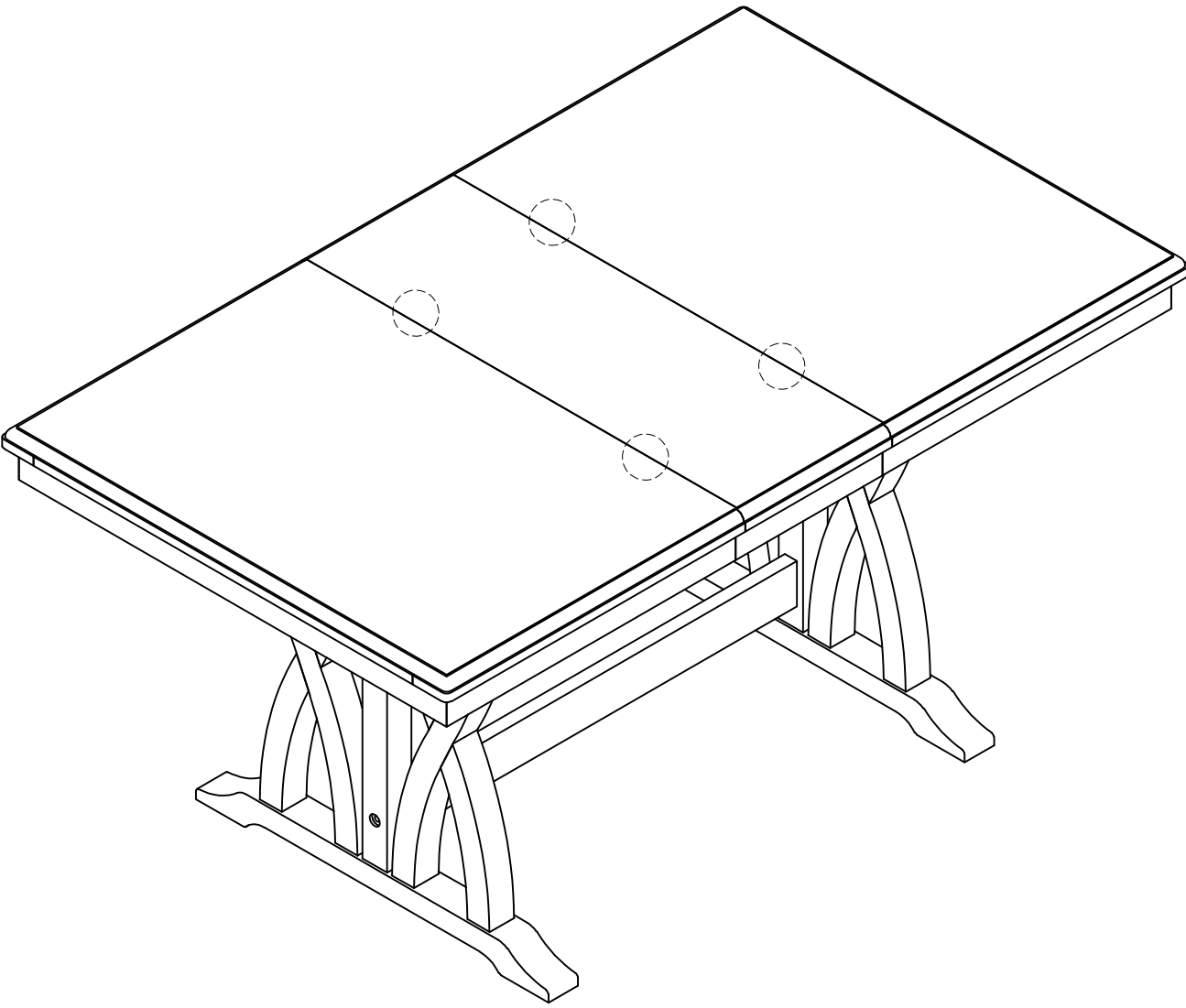

Lock the table top in place
(Verrouillez le plateau de la table en place).

ASSEMBLY INSTRUCTIONS / INSTRUCTIONS DE MONTAGE

DINING CHAIR / CHAISE DE SALLE À MANGER

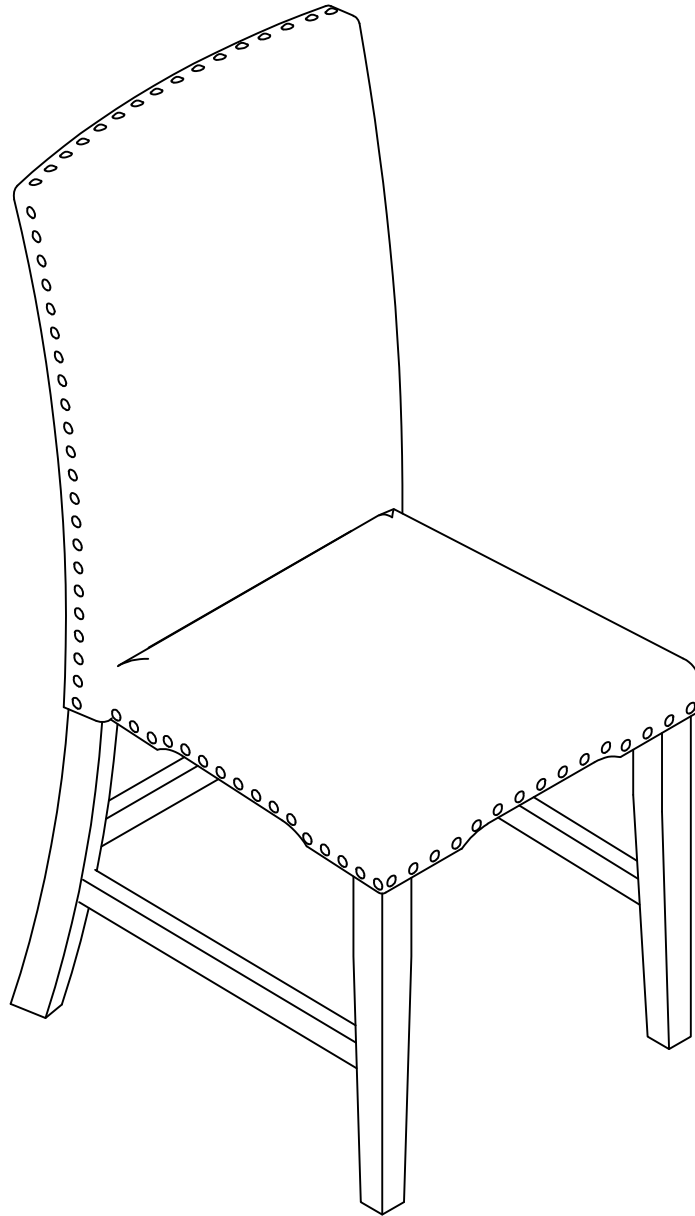



IMPORTANT NOTE :

- ① PLACE ALL PARTS ON A CLEAN AND SMOOTH SURFACE SUCH AS A RUG OR CARPET TO AVOID THE PARTS FROM BEING SCRATCHED .
PLACEZ TOUTES LES PIÈCES SUR UNE SURFACE PROPRE ET LISSE COMME UN TAPIS OU UN CARPET POUR ÉVITER QUE LES PIÈCES SONT ÉCARTÉES.
- ② BEFORE YOU BEGIN , KINDLY FOLLOW THE ASSEMBLY INSTRUCTIONS STEP BY STEP
AVANT DE COMMENCER, VEUILLEZ SUIVRE LES INSTRUCTIONS D'ASSEMBLAGE ÉTAPE PAR ÉTAPE
- ③ DO NOT TIGHTEN ALL SCREWS AND BOLTS UNTIL THE CHAIR FULLY SET-UP
NE SERREZ PAS TOUTES LES VIS ET BOULONS AVANT QUE LA CHAISE SOIT COMPLÈTEMENT INSTALLÉE

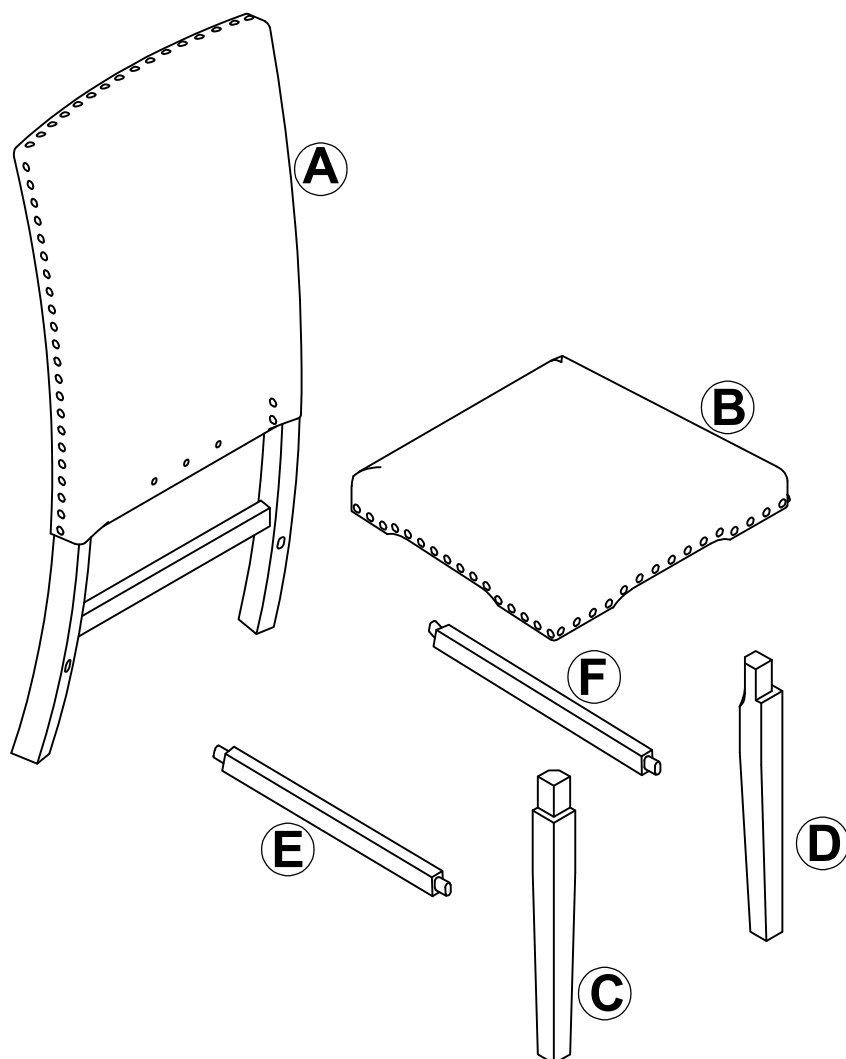



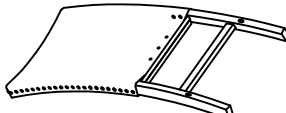
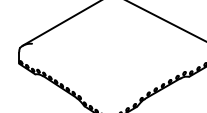
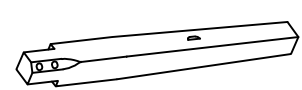

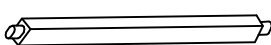
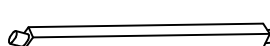
Detail View (Vue détaillée)



PARTS LIST FOR ONE / LISTE DES PIÈCES

<p>A</p>  <p>BACKREST FRAME = 1PC (CADRE DE DOSSIER) = 1PC</p>	<p>B</p>  <p>SEAT FRAME = 1pc (CADRE DE SIÈGE) = 1pc</p>	<p>C</p>  <p>LEGS LEFT = 1pc (JAMBES GAUCHE) = 1pc</p>
<p>D</p>  <p>LEGS RIGHT = 1pc (JAMBES DROITES) = 1pc</p>	<p>E</p>  <p>STRETCHED LEFT = 1pc (ÉTENDU À GAUCHE) = 1pc</p>	<p>F</p>  <p>STRETCHED RIGHT = 1pc (ÉTENDU À DROITE) = 1pc</p>

Hardware List For Chair / Liste de matériel pour chaise

<p>1</p>  <p>Bolt/ Boulon =2pcs 1/4 * 35 mm</p>	<p>2</p>  <p>Bolt/ Boulon =4pcs 1/4 * 50 mm</p>	<p>3</p>  <p>Bolt/ Boulon =4pcs 1/4 * 75 mm</p>
<p>4</p>  <p>Spring Washer/Rondelle ressort =10pcs 1/4 * 10.5mm * 1.5 mm</p>	<p>5</p>  <p>Flat Washer/ Rondelle plate =10pcs 1/4 * 19mm * 1.5 mm</p>	<p>6</p>  <p>Allen Key/ Clé Allen =1pc 4mm*60mm</p>
<p>7</p>  <p>Screw/Vis =4pcs Ø4x45mm</p>		

STEP 1 ÉTAPE 1

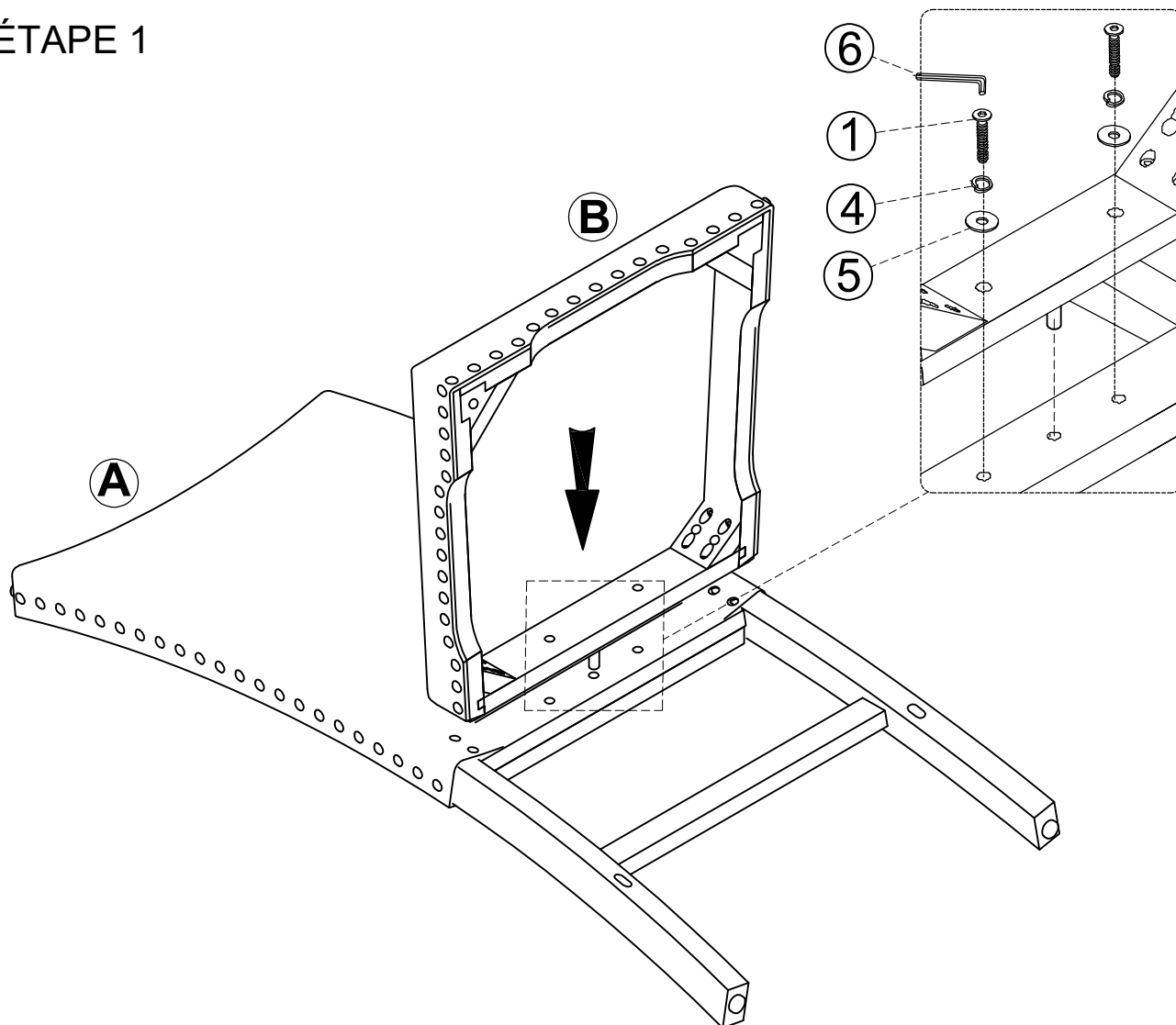

STEP 2
ÉTAPE 2

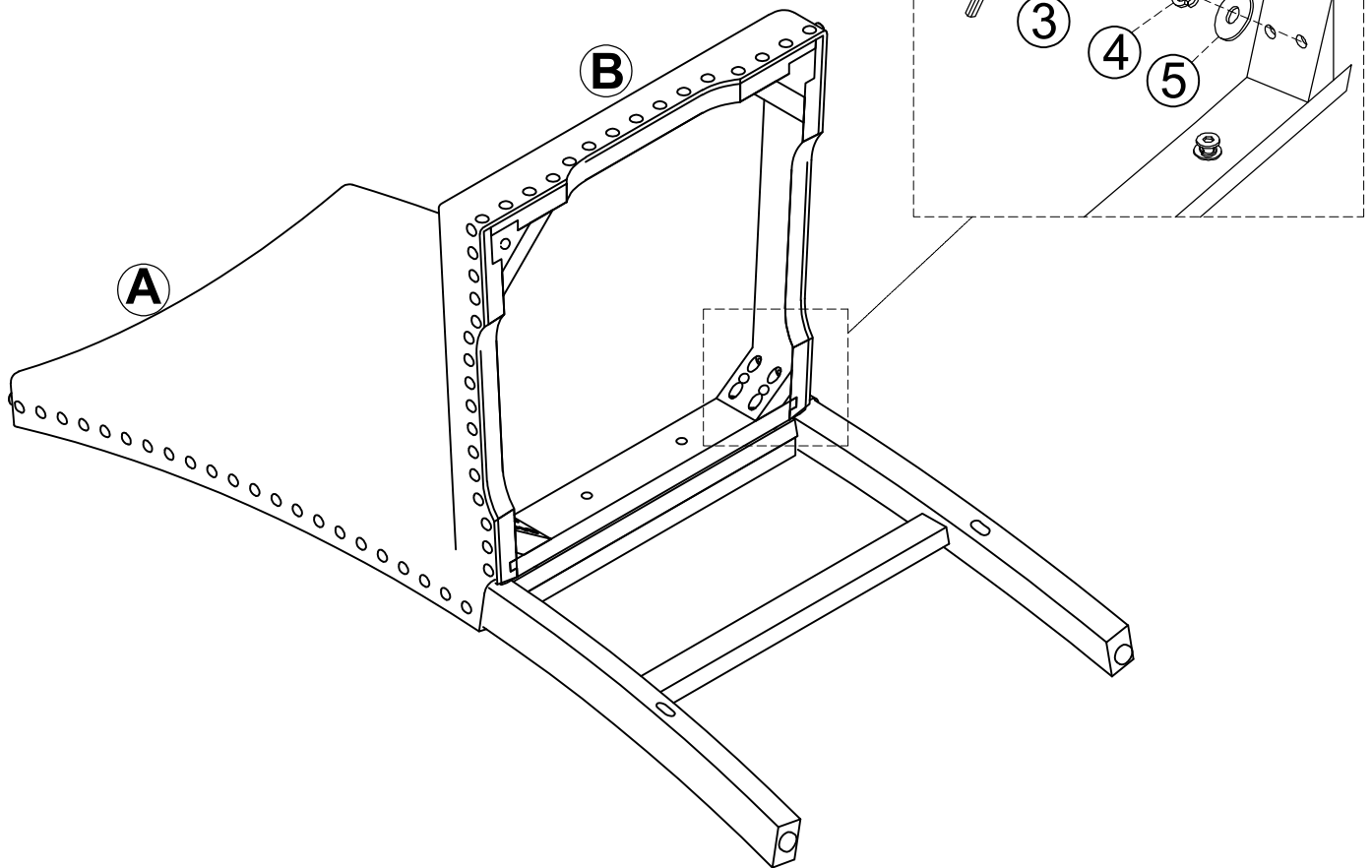

STEP 3
ÉTAPE 3

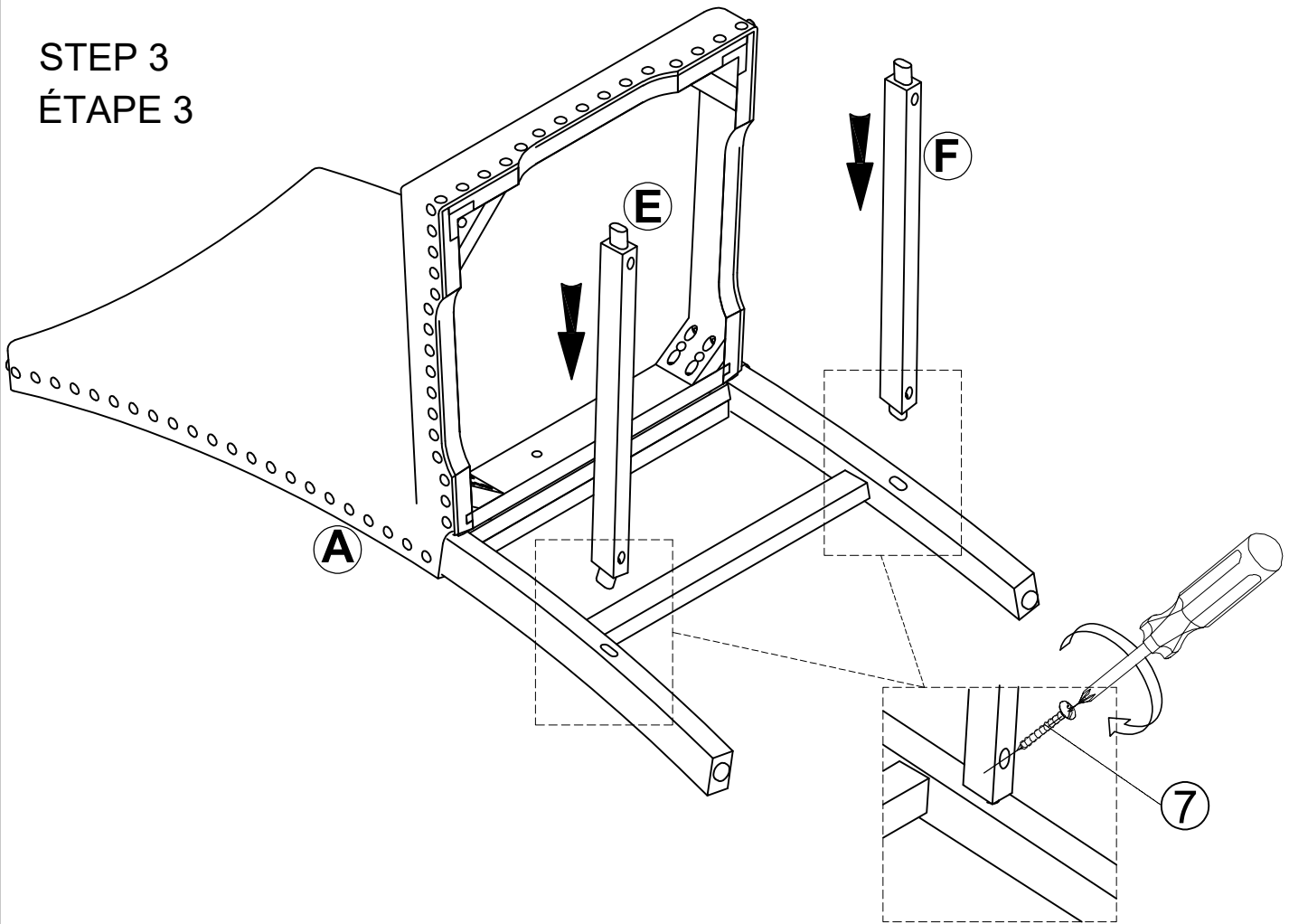

STEP 4
ÉTAPE 4

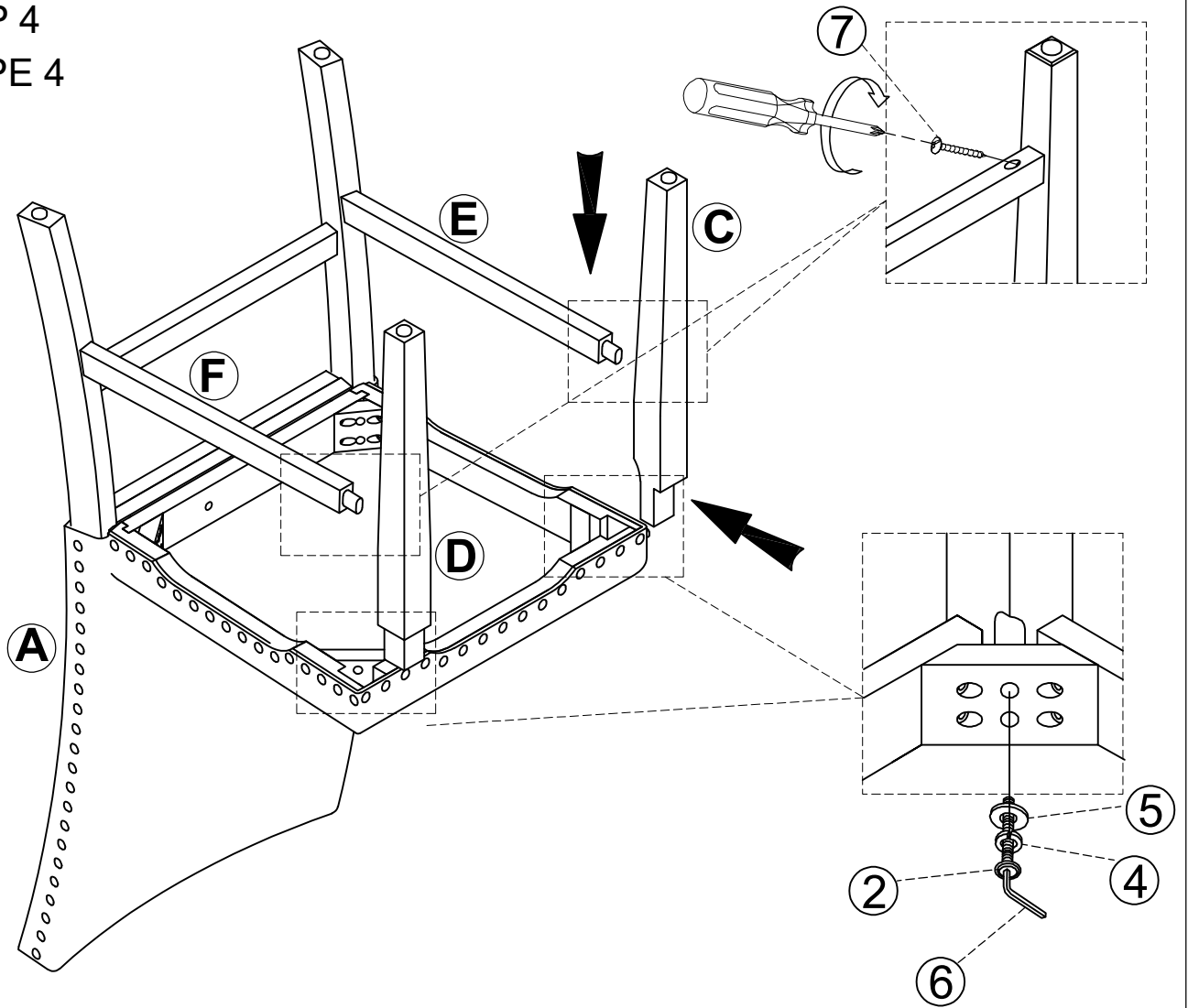

Completed Assembly
Assemblage terminé

