

Computer Desk

Installation Option I

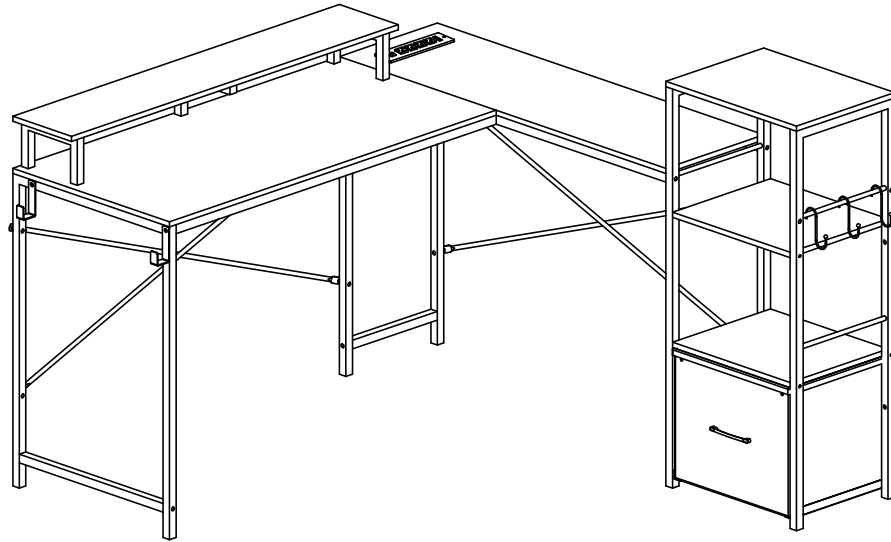

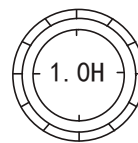

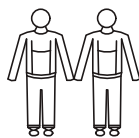
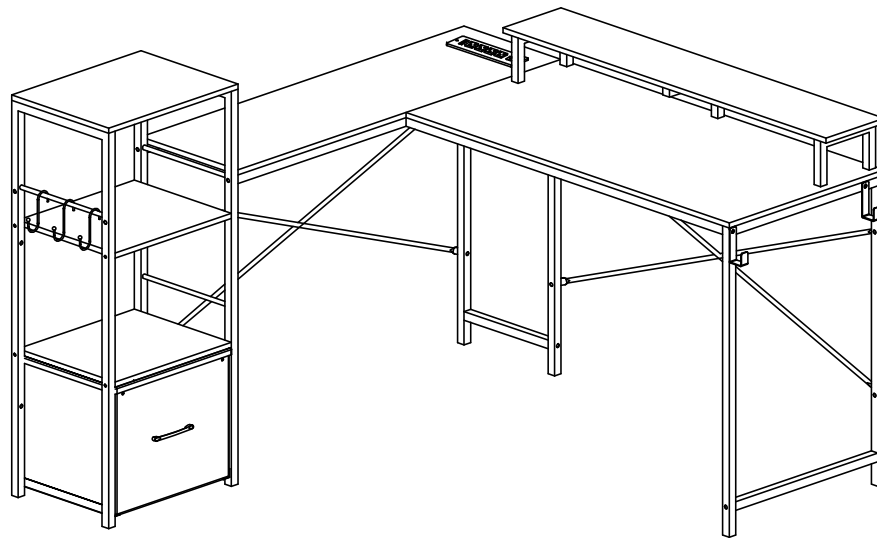



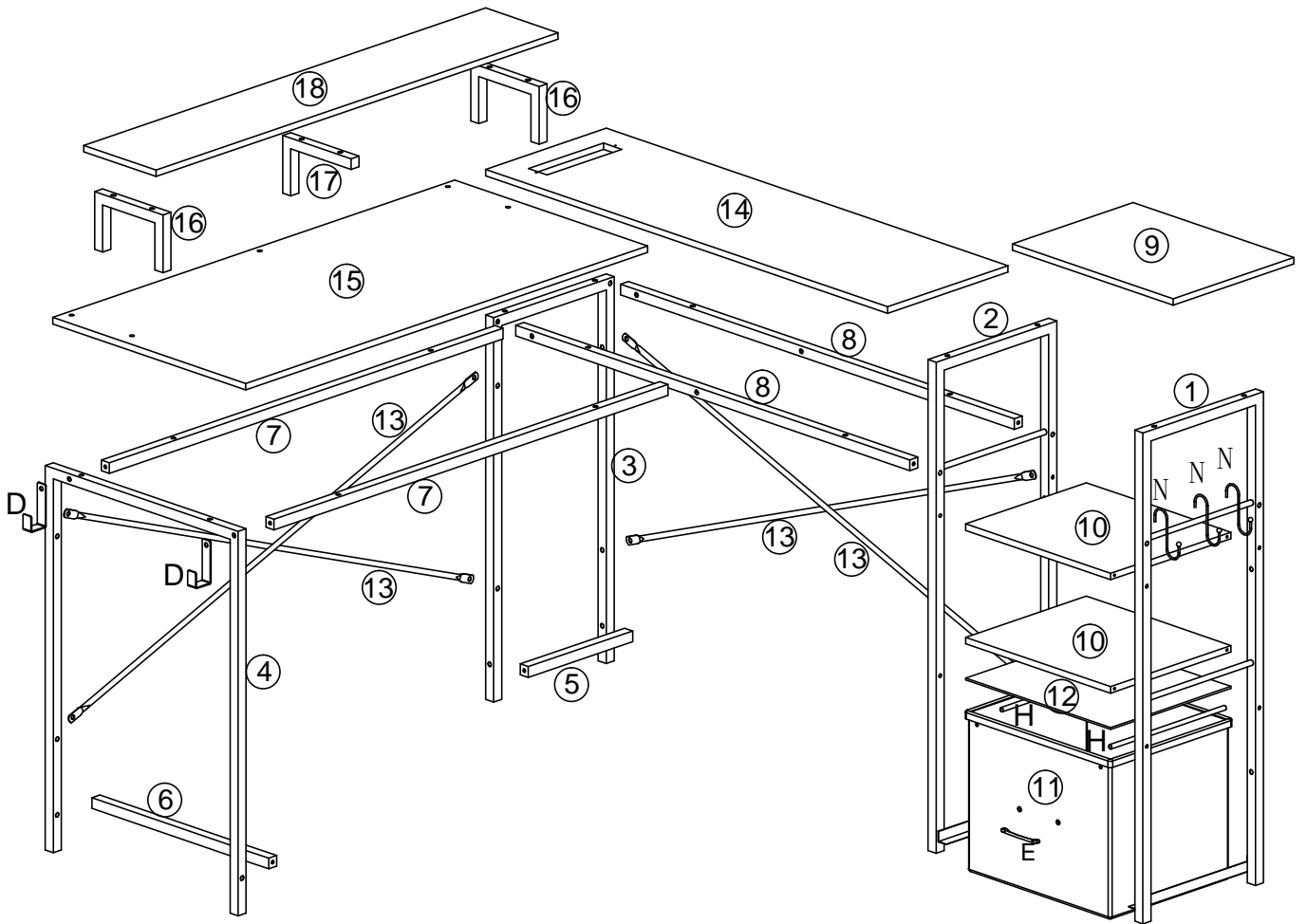







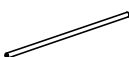

Installation Option II



GAUTION : When tightening the screws , tighten sequentially .
Do not tighten any screws fully and then towards the next one .
When every part is OK , then tighten al the screws

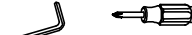

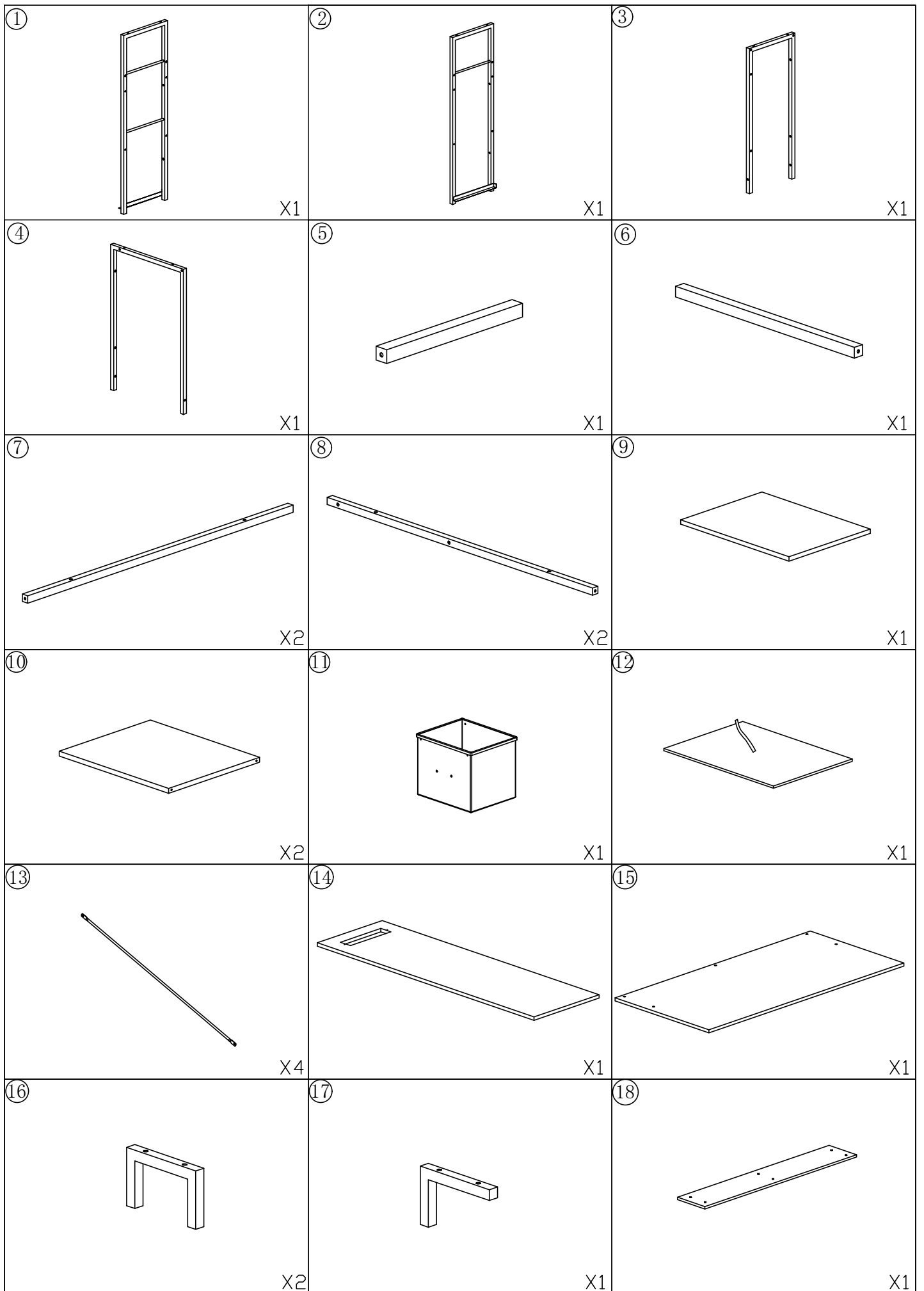

A	x8	B	x12+1	C	x8	D	x2	E	x1	F	x4
											
		M6x35		M5X38						M4x16	
H	x2	I	x22+1	J	x2	K	x1	L	X13+1		
											
		M6X25		ST3.5x12				M6X28			
M	x8	N	x3	O	x1	T	x1				
											
M6											



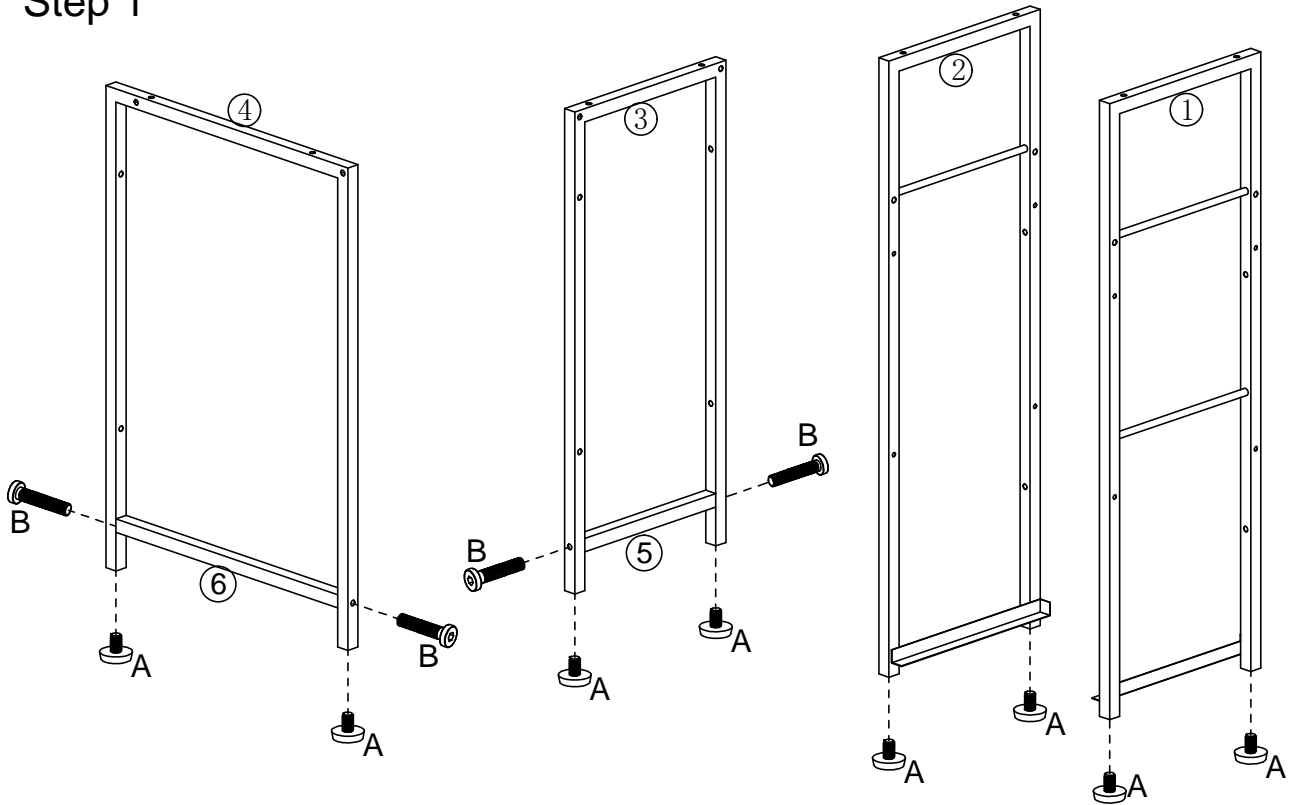

Step 1



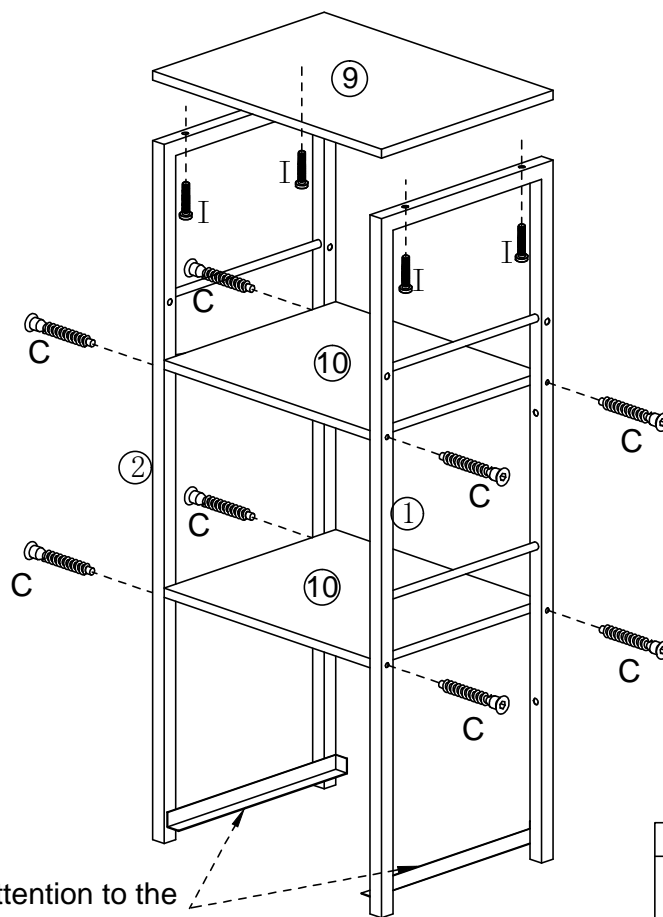

B	X4	A	X8
			
M6x35			

Step 2



 Pay attention to the orientation of the slot

I	X4	C	X8
			
M6x25		M5x38	

Step 3

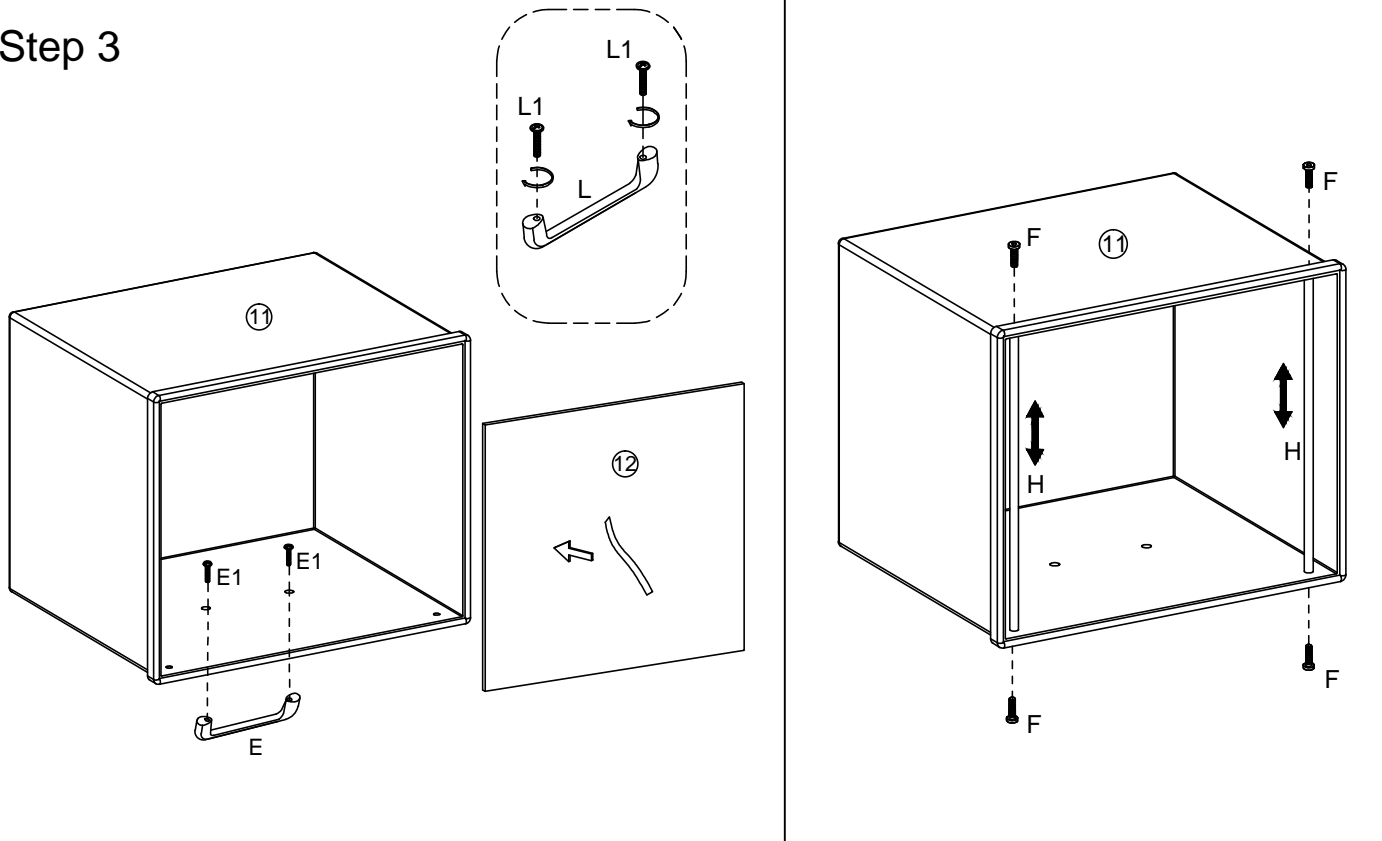

H	x2	F	x4	E	X1
		M4x16			

Step 4

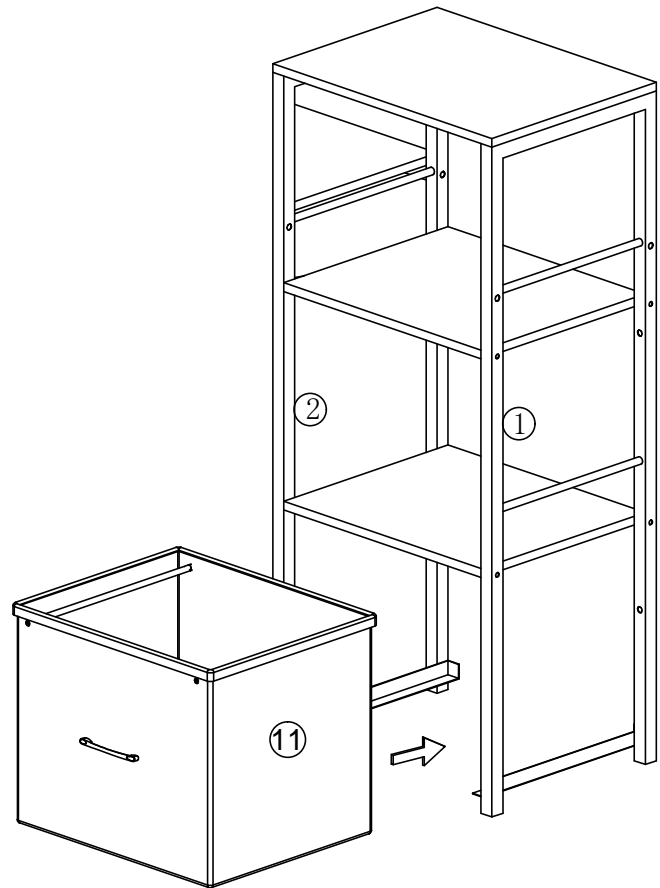

Installation Option I

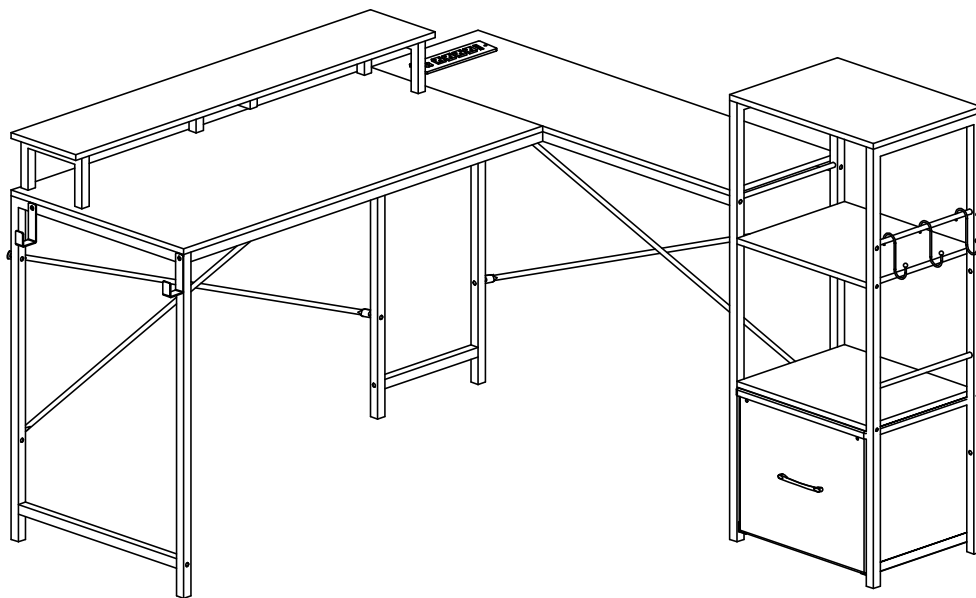

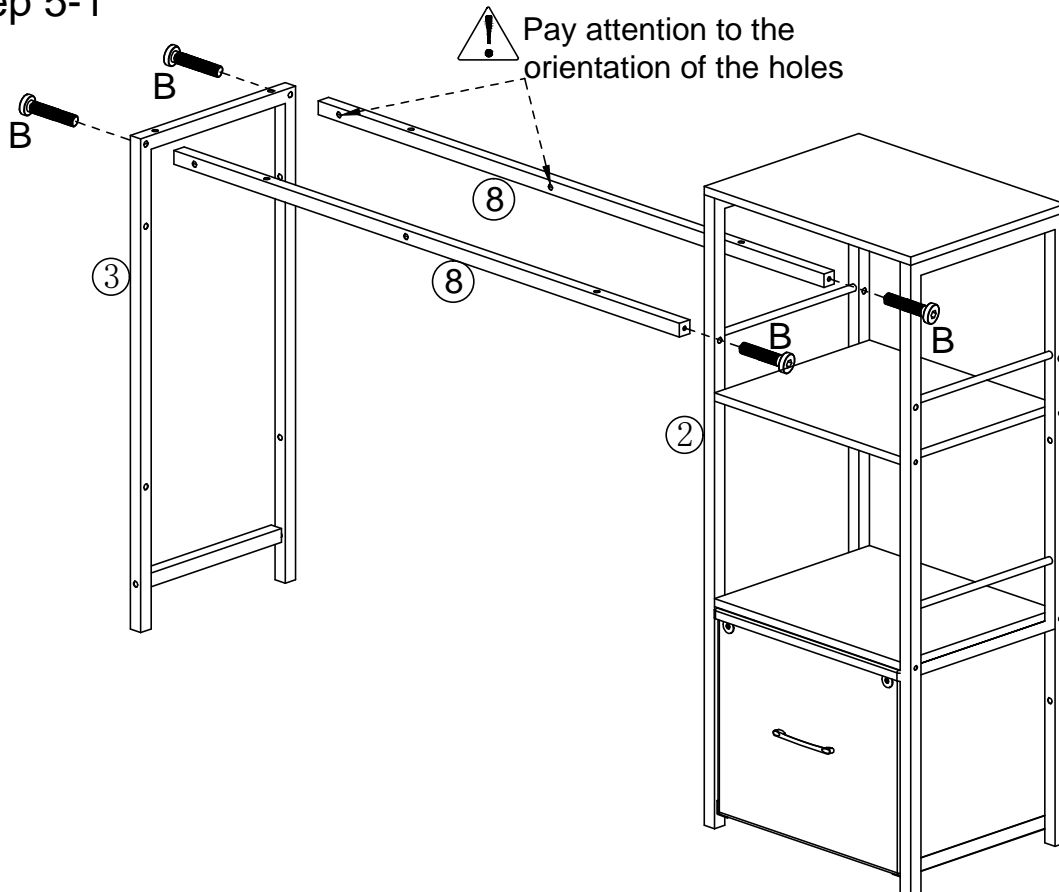

Step 5-1

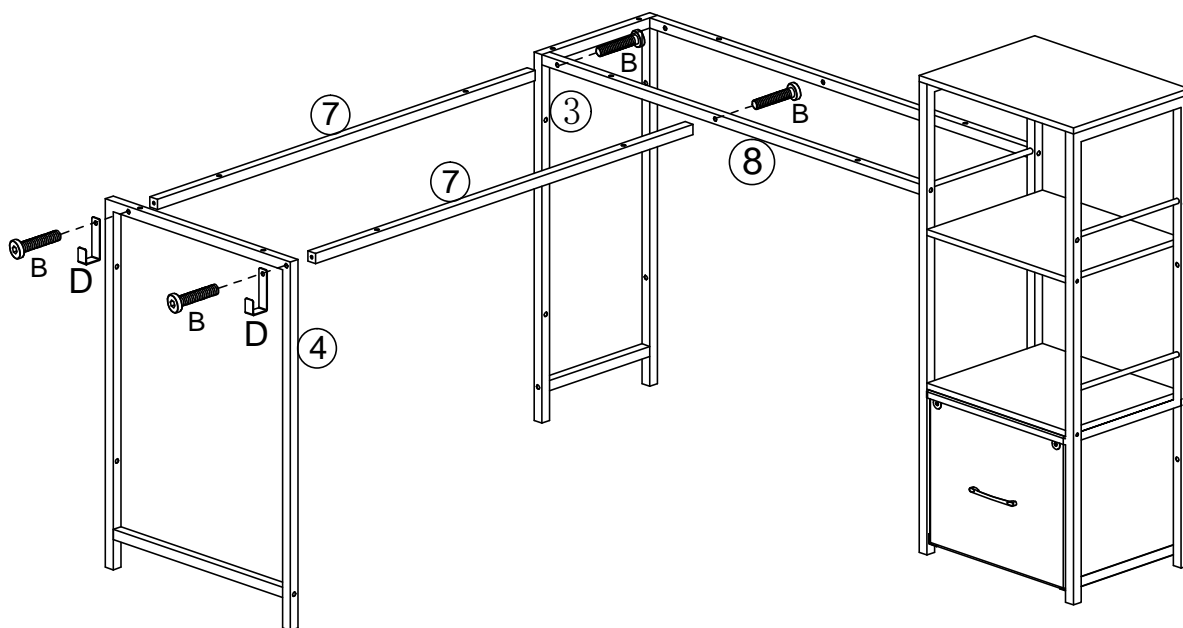

B	X4
	
M6x35	

Step 6-1





D	X2	B	X4
			
		M6x35	

Step 7-1

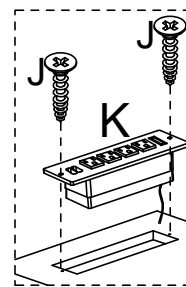
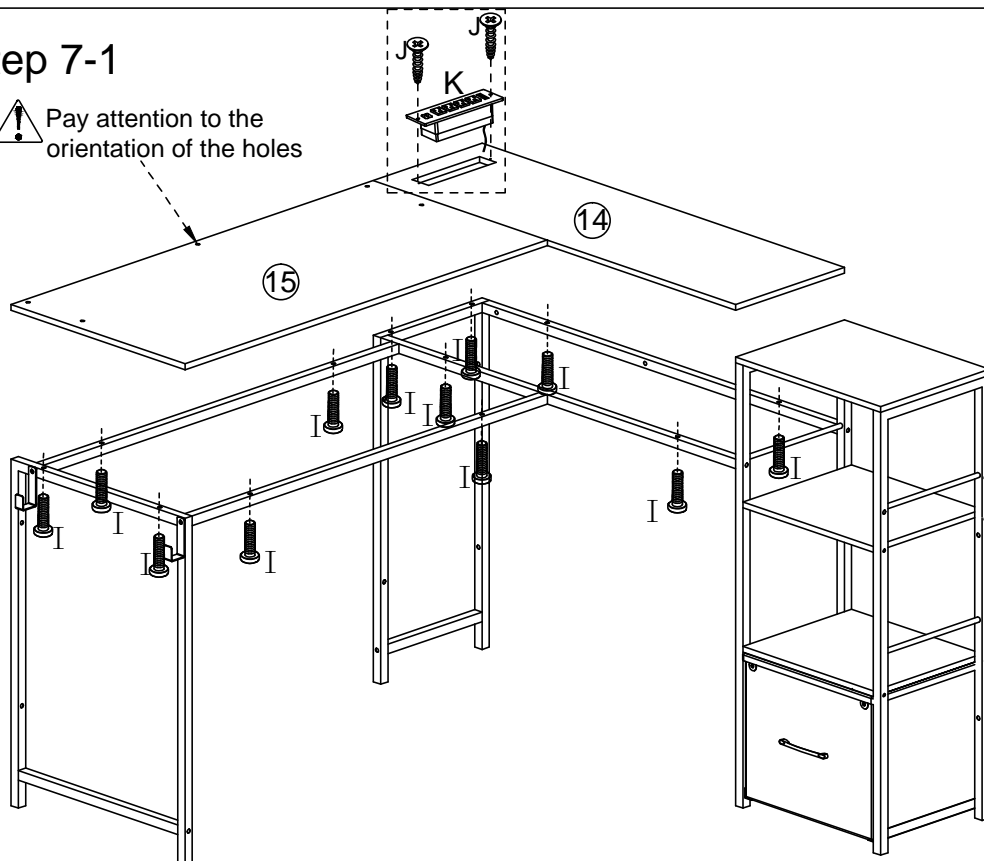
 Pay attention to the orientation of the holes



J	X2	K	X1	I	X12
					
ST3.5X12				M6x25	

Step 8-1

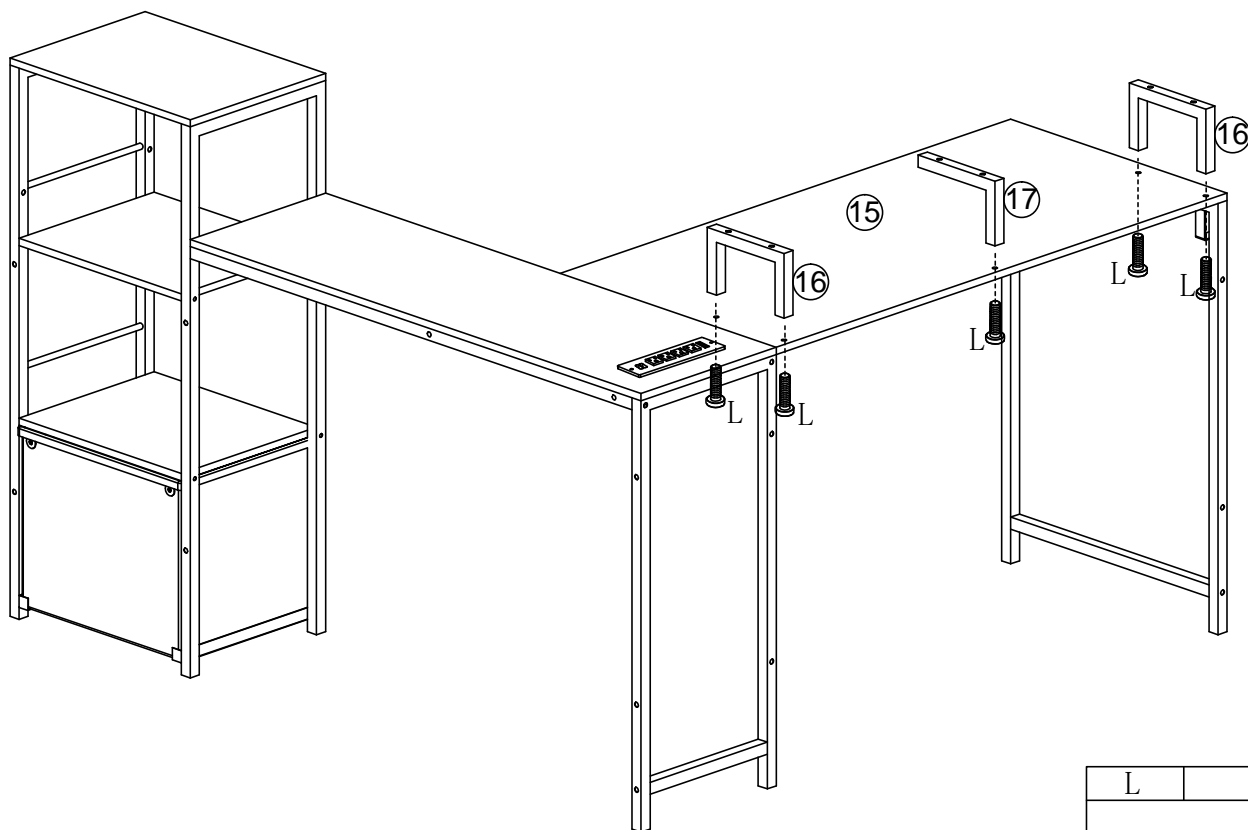

L	X5
	
M6x28	

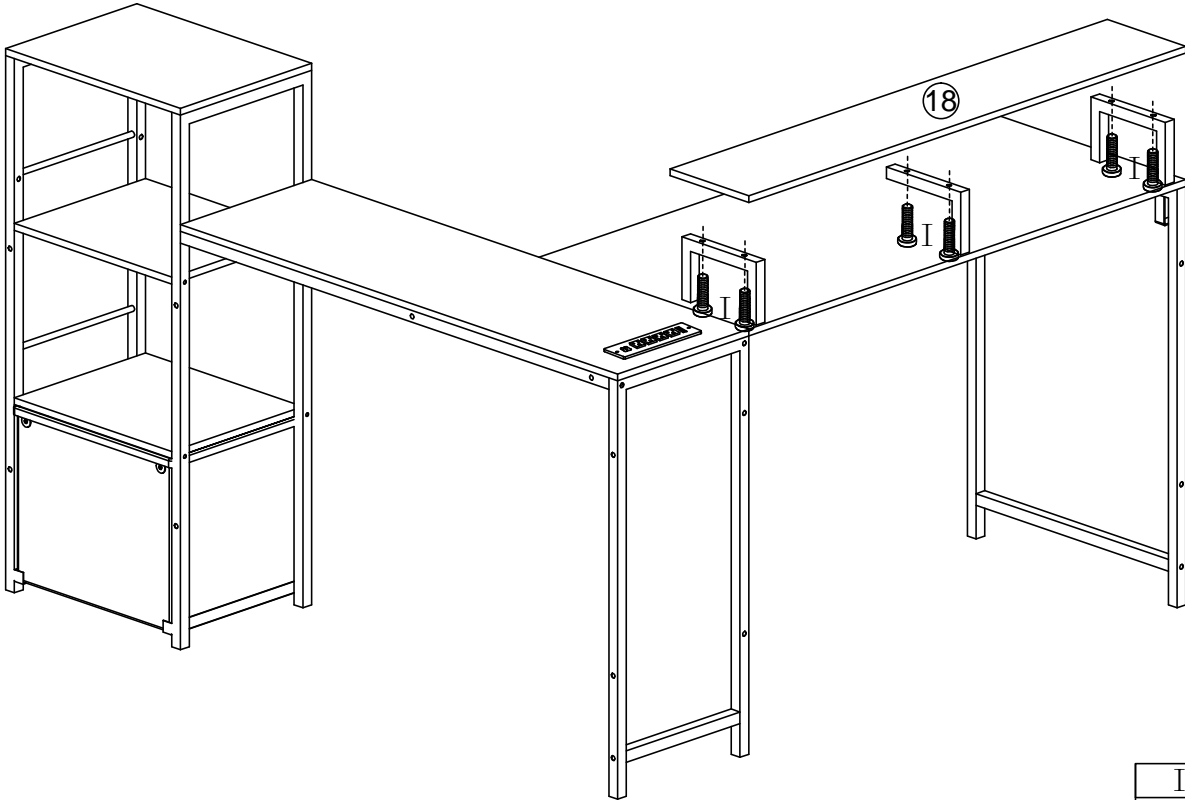

Step 9-1

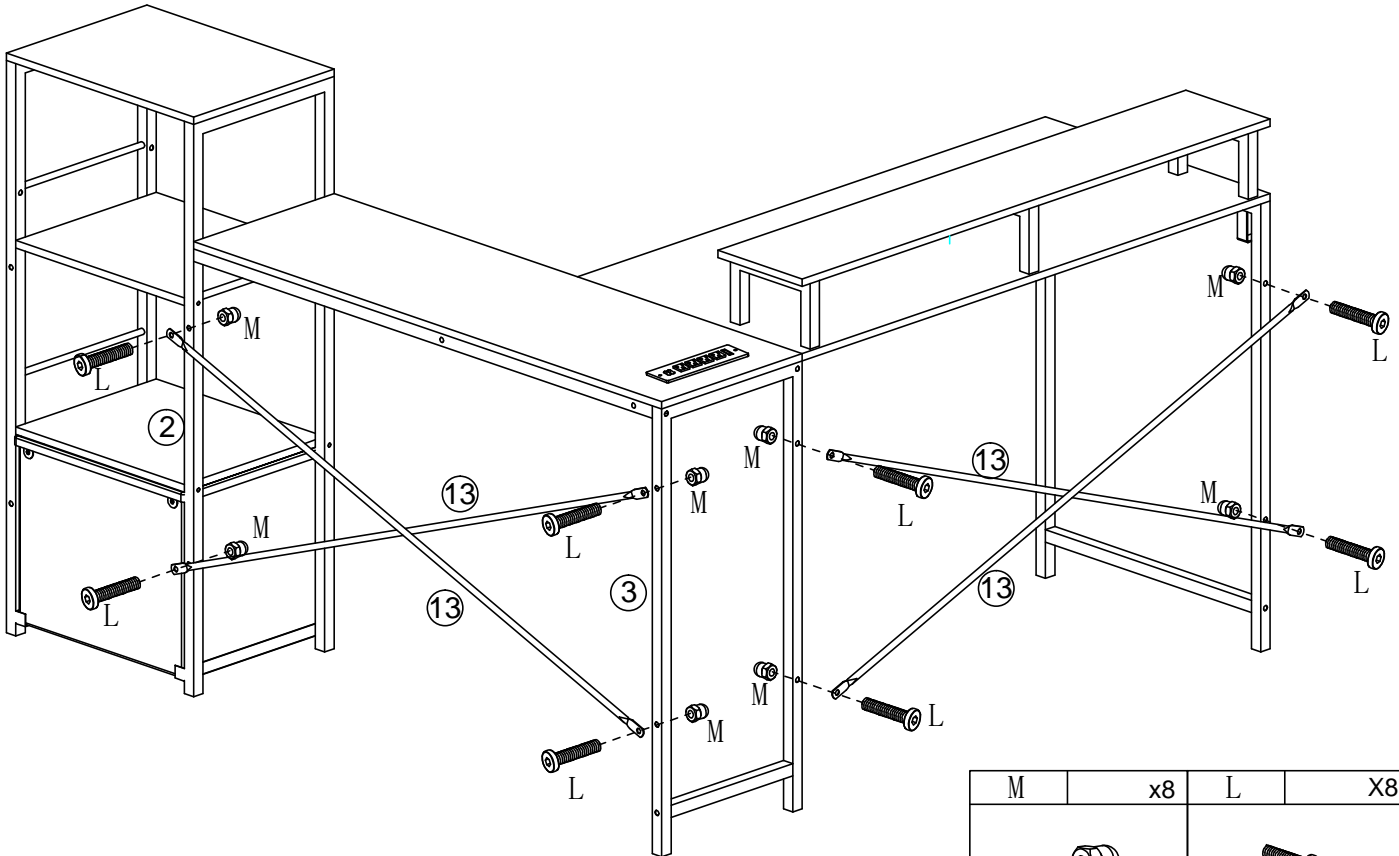

I	X6
	
M6x25	

Step 10-1



M	x8	L	X8
			
M6		M6x28	

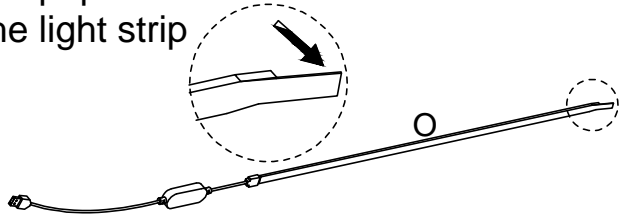

Step 11-1

Be careful to tear off the paper on the back of the light strip

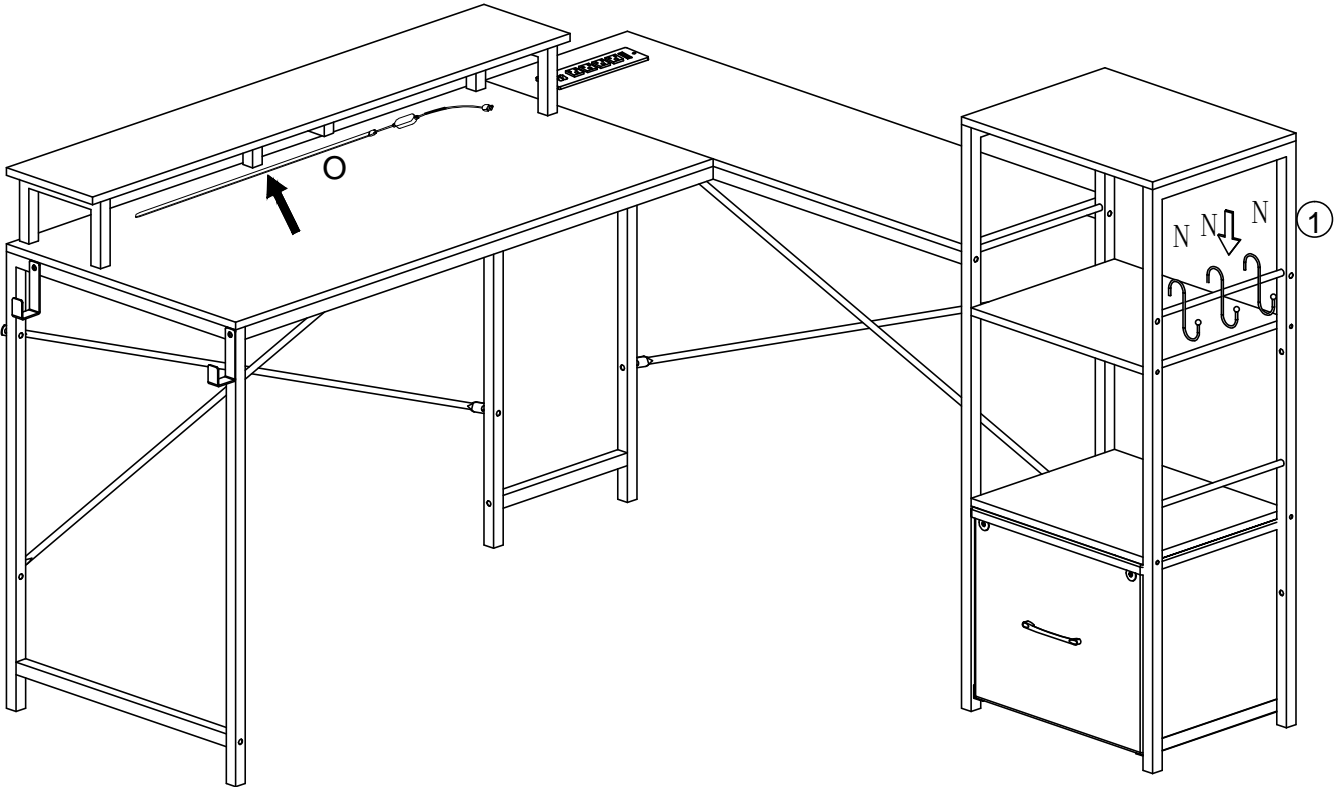

The slight strip can be pasted to the desired position according to your own needs



O	x1	N	X3
			

Installation Option II

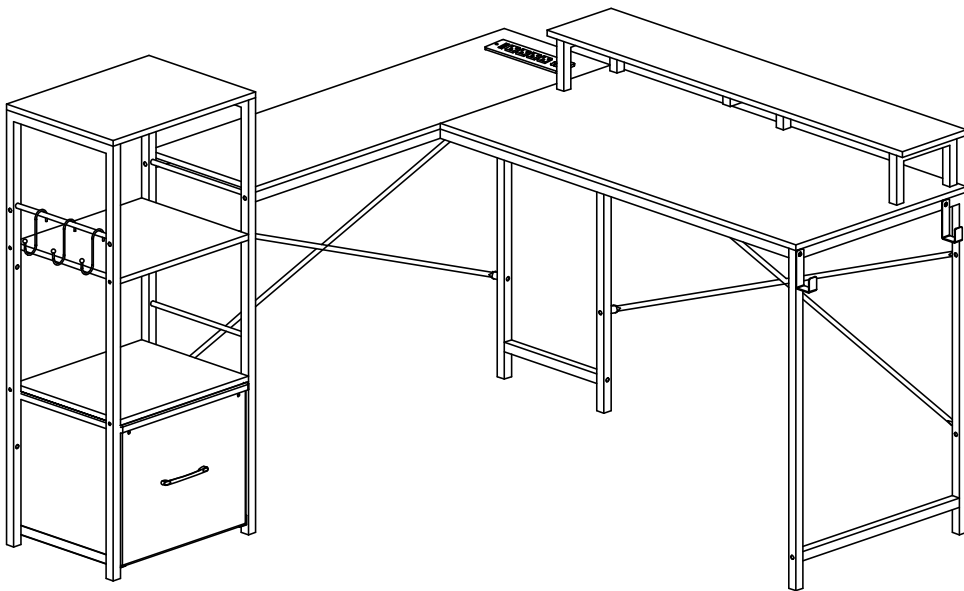

Step 5-2

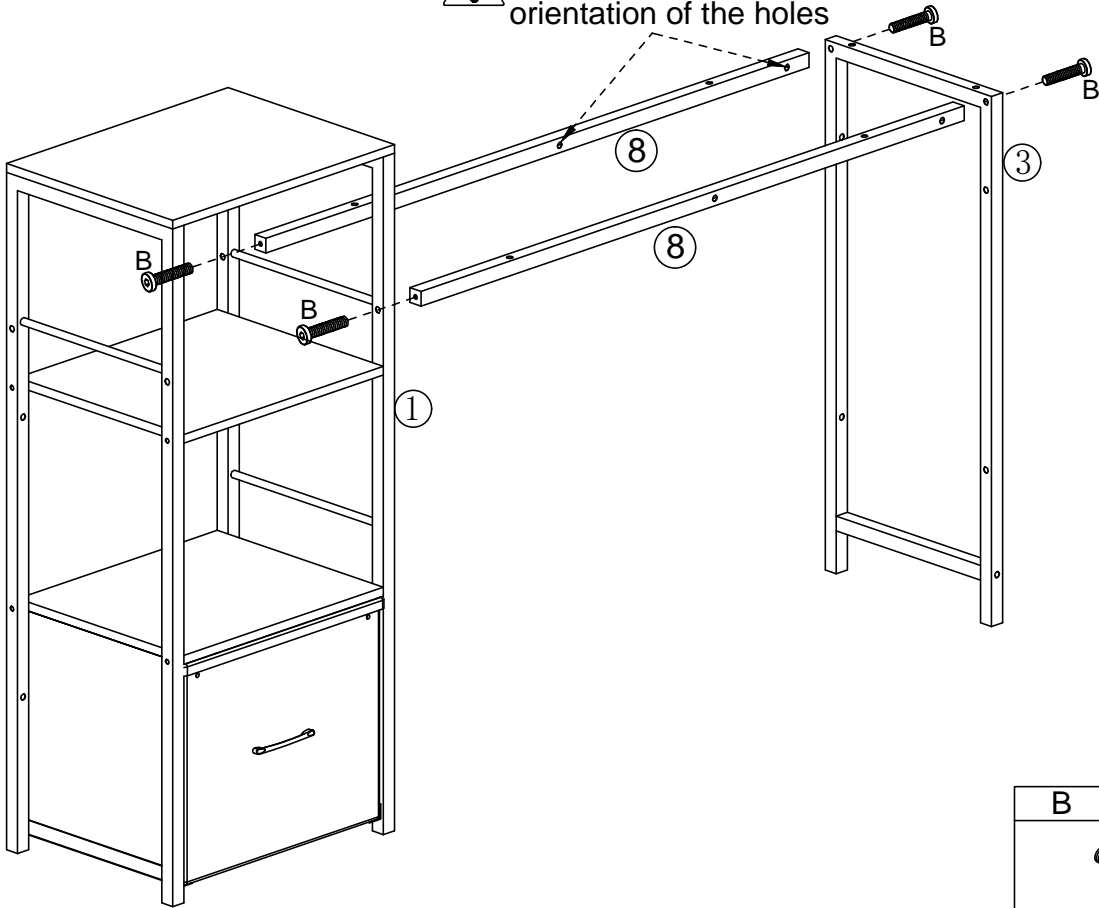

 Pay attention to the orientation of the holes



B	X4
	
M6x35	

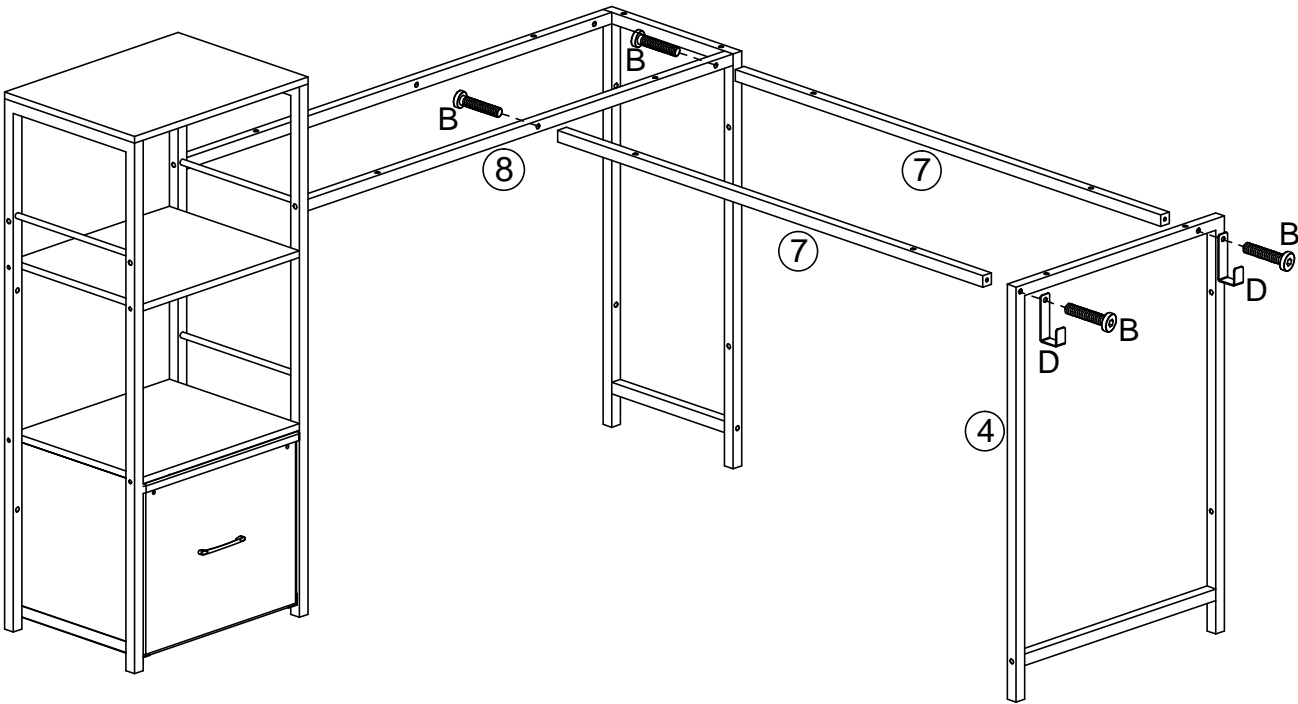

Step 6-2

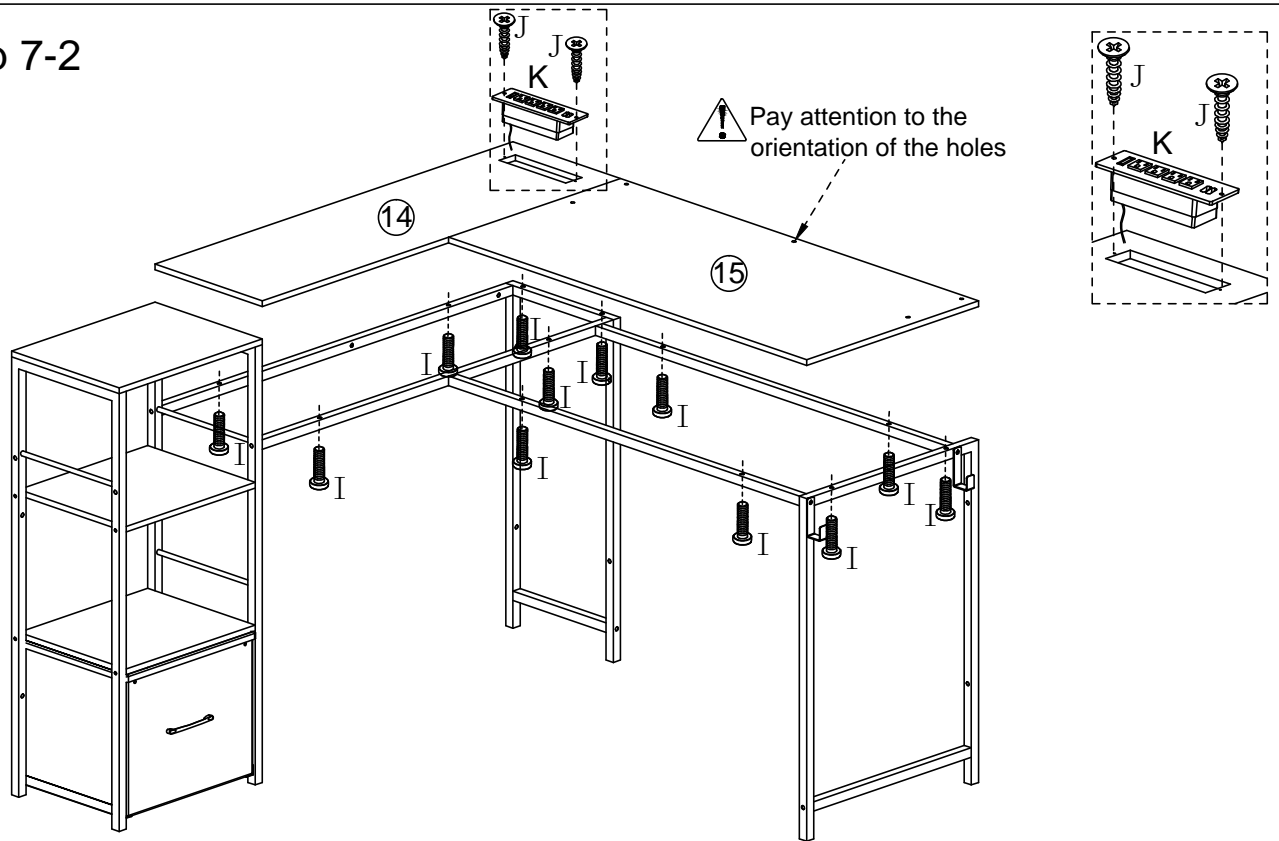

D	X2	B	X4
			
		M6x35	

Step 7-2



J	X2	K	X1	I	X12
					
ST3.5X12				M6x25	

Step 8-2

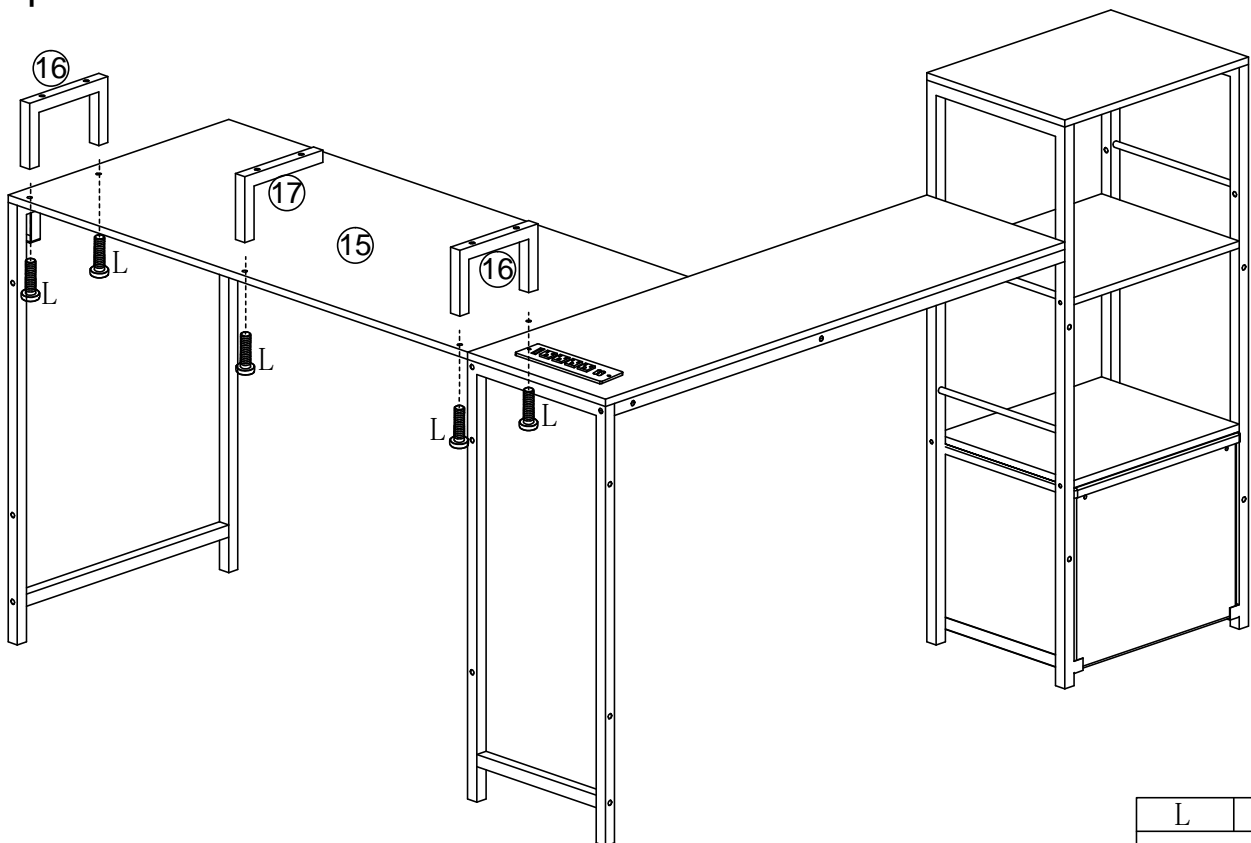

L	X5
	
M6x28	

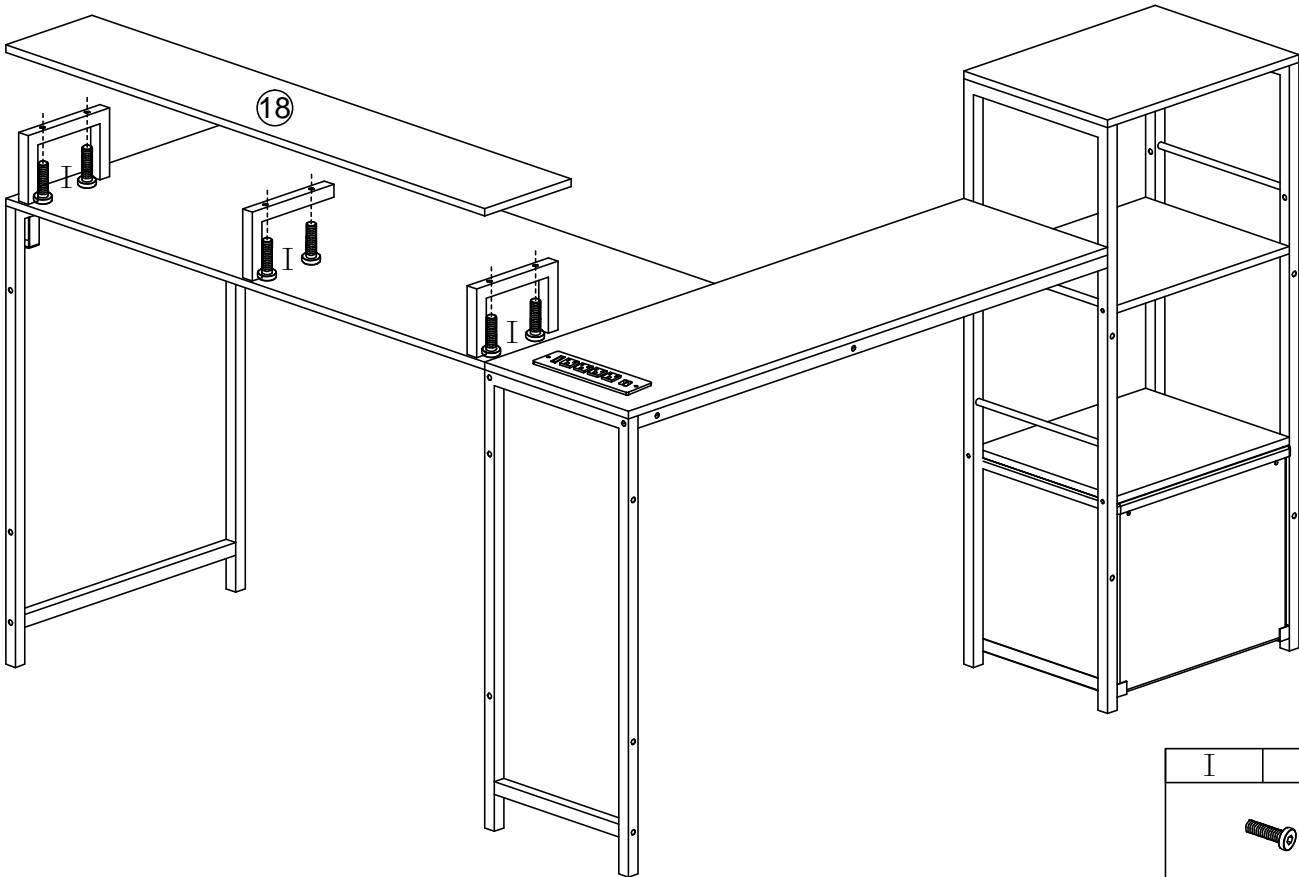

Step 9-2

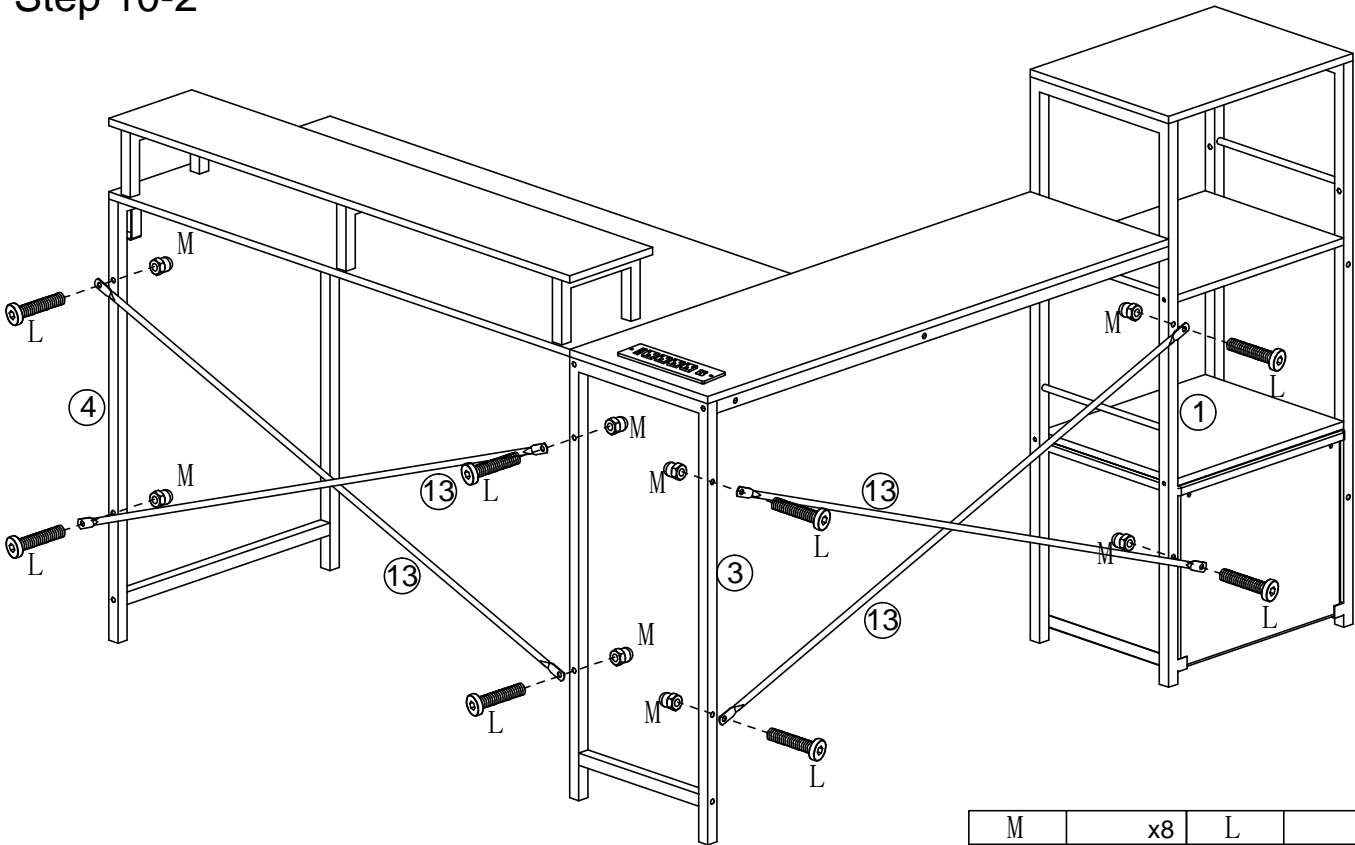

I	X6
	
M6x25	

Step 10-2



M	x8	L	X8
			
M6		M6x28	

Step 11-2

Be careful to tear off the paper on the back of the light strip

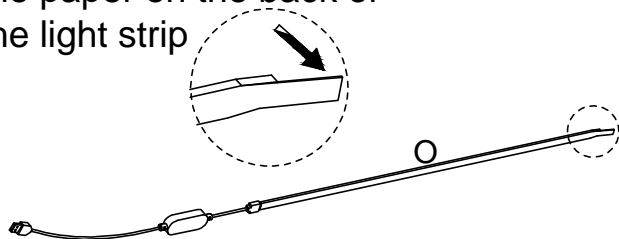

The light strip can be pasted to the desired position according to your own needs

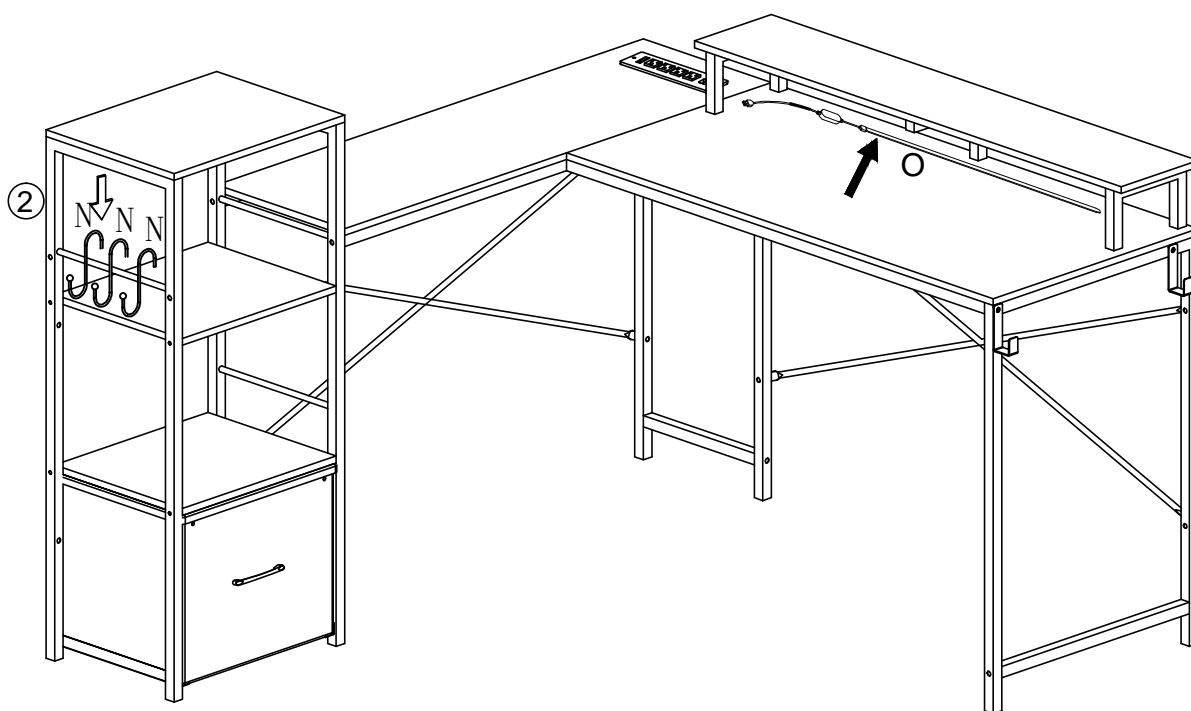

O	x1	N	X3
