

# TRAMPOLINES

## USER MANUAL

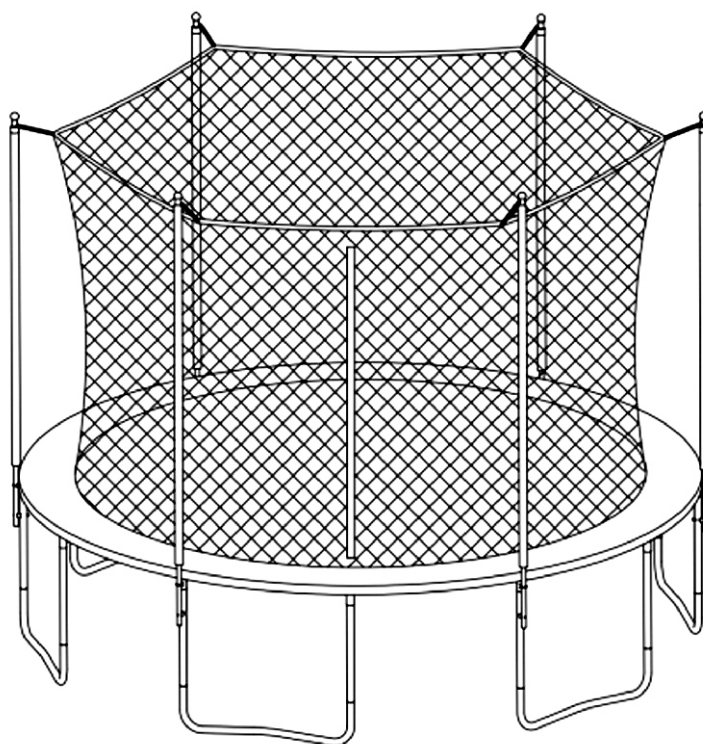

Please contact us if you have any questions about the delivery.

**PLEASE DO NOT RETURN TO STORE**



**Please do not return this product to the retailer!!**

**We are able to assist you in ANY way.**

If you find that you have any trouble with assembly or  
missing or damaged parts, please contact the seller.

Before using your trampoline, it's important to carefully read all the information in this manual and retain it for further reference. Like any recreational physical activity, participants can be injured. To reduce the risk of injury, please be sure to follow the appropriate safety rules and tips.

- Incorrect use of this trampoline can be dangerous and cause serious injury!
- When jumping on a trampoline you may reach heights and adopt positions to which you are not accustomed. Take great care and learn the required techniques.
- Always inspect the trampoline before each use.
- Assembly, maintenance, safety tips, warnings, and basic jumping techniques are covered in this manual. All users and supervisors must read and familiarize themselves with these instructions.

Initially, you should get accustomed to the feel and bounce of the trampoline. The focus must be on your body position and you should practice each fundamental bounce until you can do each skill with a bounce before moving on to more difficult and advanced bounces. Do not bounce recklessly on the trampoline, emphasis must be made on good control and the mastering of various bounce techniques.

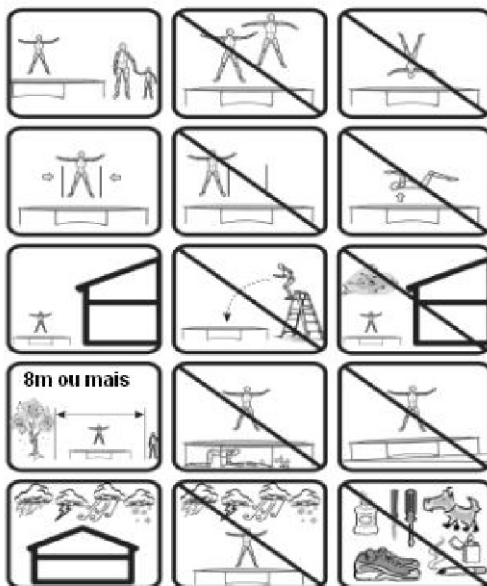

No more than one person is allowed on the trampoline at the same time!



Do not perform somersaults (flops) as these can be very dangerous for your head and neck!

# ***TRAMPOLINE GUIDELINES***

## **1. GENERAL INSTRUCTIONS**

### **1.1 PURPOSE**

- The product is intended for home/domestic use only and is not suitable for professional or medical uses.
- Overloading the trampoline above the recommended user weight will cause damage to the trampoline which is not covered by the warranty

### **1.2 DANGER FOR CHILDREN**

- Do not let unsupervised children near this product. Carry out the necessary safety precautions and supervise all trampoline activities. Be aware that the packaging material is not suitable for children to avoid danger of suffocation!
- Children do not recognize potential dangers from this product. The product has to be stored out of reach of children and pets.

### **1.3 ATTENTION - PRODUCT DAMAGES**

- Do not alter the product. Only use original spare parts. Repairs should only be carried out by qualified technicians. Improper repairs can compromise the safety of your trampoline. Use this product only as described in this manual
- Protect the product against humidity and high temperatures.

### **1.4 ADVICE FOR THE ASSEMBLY**

- The assembly of the product must be done carefully by at least two able-bodied adults. If in any doubt, ask a technically qualified person.
- Before you start assembling the trampoline, read all the instructions in this manual.
- Remove all packaging materials and lay down all parts in a free space. This gives you an overview and simplifies the assembly procedure.
- Check with the parts list that no parts are missing. Dispose of the packaging material when the assembly is completed
- Beware that when using tools or doing technical work, there is always a risk of injury. Therefore, assemble the product carefully.
- Create a danger free environment, for example: do not let tools lie around the workspace.
- Store the packaging material in a way that cannot cause any danger. Foils and plastic bags are dangerous for children (danger of suffocation)!
- After installing the product according to the instruction manual, please make sure that all screws, bolts and nuts are correctly installed and tightened and that all joints are tightly fixed.
- A clearance space of at least 24feet is necessary above the trampoline.

- An appropriate clearance must be kept between the trampoline and possible sources of danger, such as electric cables, tree branched, playing devices, swimming pools and fences.
- The trampoline must be set up properly before use.
- Never set up the trampoline in rainy, windy or stormy conditions, especially lighting conditions. It is recommended that the trampoline be taken apart and stored in bad weather.
- The metal frame of the trampoline will conduct electricity. Lightning, extension cords and all electrical equipment must never be allowed to come in contact with the trampoline.
- The trampoline must always be used in a well-lit area.
- Do not place any objects under the trampoline.
- The trampoline in the vicinity of other leisure devices and constructions must not be used.
- When assembling or disassembling, please use gloves to protect your hands.

#### **1.5 ADDITIONAL TIPS**

- For additional stability, you can place sandbags on the trampoline legs. This will prevent the trampoline from tipping over in the event of any sideways force.
- Do not use during pregnancy.
- Do not use when suffering from high blood pressure.
- Jump with bare feet. Do not wear shoe, this will damage the jumping mat which is not covered by the warranty.
- No smoking.
- Do not put cigarettes, pets, sharp objects, or any other foreign objects on the trampolines.
- Do not use the trampoline whilst under the influence of alcohol or drugs.
- Do not sit or lean on cover pads as it may move with the jumping mat. Please do not allow children to pull themselves up the trampoline with hands-on the cover pad.
- Place trampoline on level ground. Preferably on the grass. Locating the trampoline on a hard surface will add stress to the frame and overtime cause damage which is not covered by the warranty. Placing the trampoline on uneven surfaces may result in the trampoline tipping over.
- Do not expose the trampoline to direct contact with open flames.
- Never use the trampoline when it is wet, damaged, dirty or worn out.
- Trampoline should be tied down with anchors during windy conditions or dismantled and stored away.
- Damage caused to your trampoline as a result of weather events such as rain, wind , snow, water, fire, lightning etc. are not covered under the warranty.

### **WARNING**

1. Please ensure that the safety enclosure net zipper is 100% closed and all three entrance hooks are re-hooked before jumping.
2. Do not intentionally jump into the safety net, it is only designed to stop persons from falling off the trampoline. Intentional jumping into the safety net may cause the trampoline to top over, or damage your net. Abuse of the safety net is considered negligent use which is not covered by the warranty, please refer to the disclaimer.

## **2. SAFETY INSTRUCTIONS FOR TRAMPOLINES**

- All users need to be supervised regardless of skill level or age.
- The safety instructions of the trampoline should always be considered and obeyed.
- Do not perform somersaults must of any type on this trampoline. Incorrect landings on the trampoline can lead to injuries, particularly to the back, neck or head. Injuries may include paralysis or even death.
- Only one person should use the trampoline at a time. Multiple users increase the occurrence of injury as they can cause you to lose control, collide, or land on the frame or springs.
- Inspect the trampoline for damage, wear or defective part before each usage, as it can impair the overall safety of the trampoline. The damaged, wearing or defective parts should be replaced immediately. In the meantime, the trampoline must be restricted from access.
- No clothes with hooks or parts may be carried when jumping on the trampoline, in order to avoid hooks getting caught.
- The trampoline must be set up only on flat ground and non-slippery surfaces.
- Strong wind can blow the trampoline away. If strong winds are predicted, the trampoline must be moved to a sheltered place and taken apart. Or it should be fastened to the ground with wind stakes.
- Try to avoid moving the assembled trampoline, because the frame could bend during transportation. Should it be necessary to move the trampoline, please consider the following: at least four people must be evenly spaced around the frame to lift the trampoline off the ground. The trampoline must be carried horizontally, and if the frame shifts position, have four people to restore the original shape.
- Trampoline is jumping devices, enabling the user to jump to unusual heights as well as into a multiplicity of body movements. Jumping into the trampoline. Hitting the frame, cover pads or incorrect landing on the trampoline can lead to injury.
- Users should be familiar with the user manual in order to ensure a secured and fun use of the trampoline. This manual contains assembly instructions, selected precautionary measures as well as recommendations for servicing and maintenance of the trampoline.
- It is the responsibility of the owner/supervisor to guarantee that all users of the trampoline are informed of sufficient space around it as a safety precaution.
- Never use it near water and keep sufficient space around it as a safety precaution.

- Beware of moving parts that could catch your arms and legs and cause injury.
- Do not stick any foreign objects into the trampoline.
- The jumping mat is flexible and there's downwards force created by someone jumping. Therefore, do not allow anyone or any object to go under the trampoline whilst someone is jumping on the mat, otherwise, there will be an increase in the chance of an injury occurring.
- Implement all safety rules and make yourselves familiar with the information in the user manual.
- The trampoline can be only used when the jumping mat is clean and dry. Worn or damaged jumping mats should be replaced immediately.
- Remove all objects that may be dangerous from people using the trampoline.
- Avoid unauthorized and unsupervised use of the trampoline.
- Do not use the trampoline under influence of alcohol or drugs (include medicines).
- Learn the fundamental jumping techniques thoroughly before trying difficult jumps. For more information, see the Fundamental Bounce Techniques section.
- Climb on the trampoline. Do not jump on it directly. Do not use the trampoline as a jump board for other articles. For more information, see the Accident Categories: Mounting and Dismounting section.
- For further information or exercise documents, you can consult a trained trampoline teacher.

## **TRAMPOLINE BOTTOM FRAME PARTS LIST**

Part No.	Part Name	14FT QTY	15FT QTY	16FT QTY
A	TOP RAIL	12	10	12
B	COVER PADS	1	1	1
C	JUMPING MAT	1	1	1
D	SPRINGS	72	90	108
E	LEG EXTENSION	12	10	12
F	LEG BASE	6	5	6
G	SHORT SCREW	18	10	12
H	SPRING FIXING TOOL	1	1	1
I	T JOINT	12	10	12

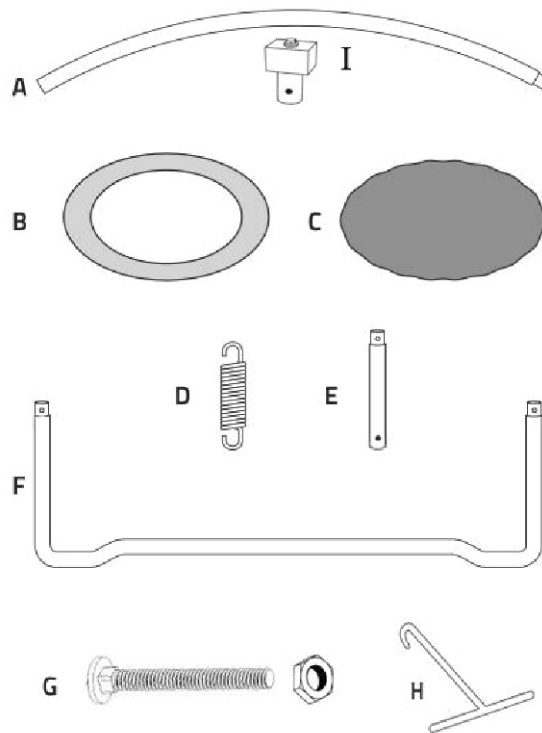

**STEP 1.**

Insert the Top Rails (A) into the T Joint (I) and secure with screw pre-installed in the T Joint.

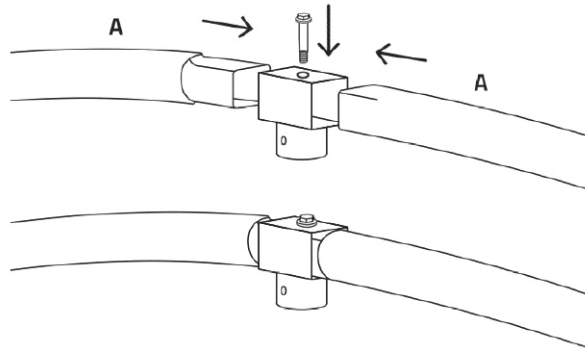

**STEP 2.**

Repeat the step until all Top Rails (A) are connected.

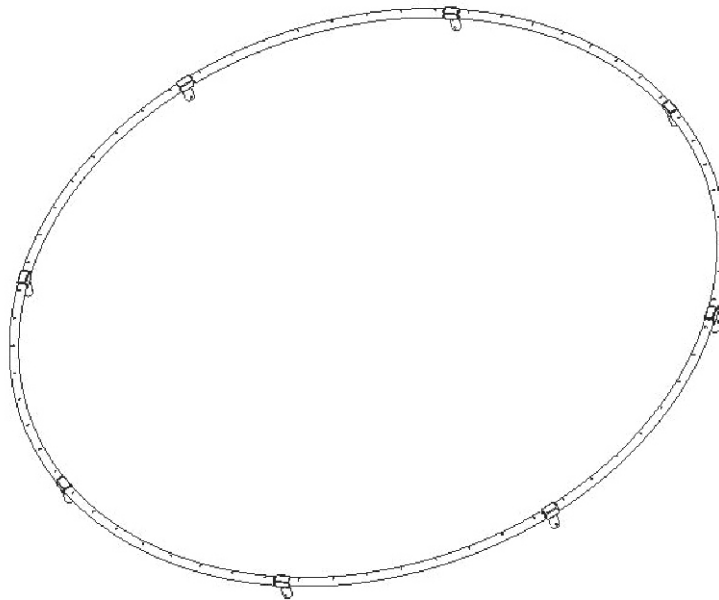

**STEP 3.**  
Slide the Leg Extensions (E) into Leg Base (F) and secure with Short Screws (G).

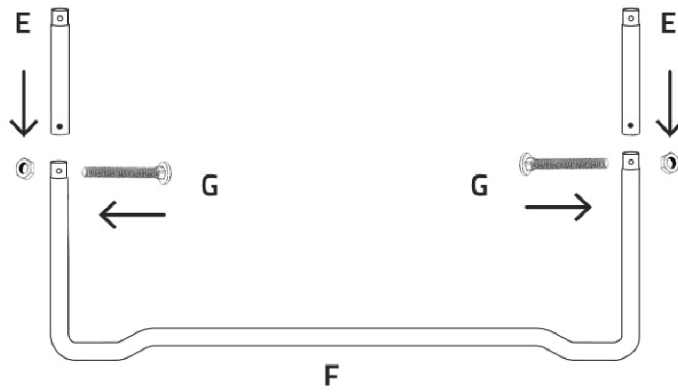

**STEP 4.**  
Connect the Leg Extensions to T Joint (I) as shown below.

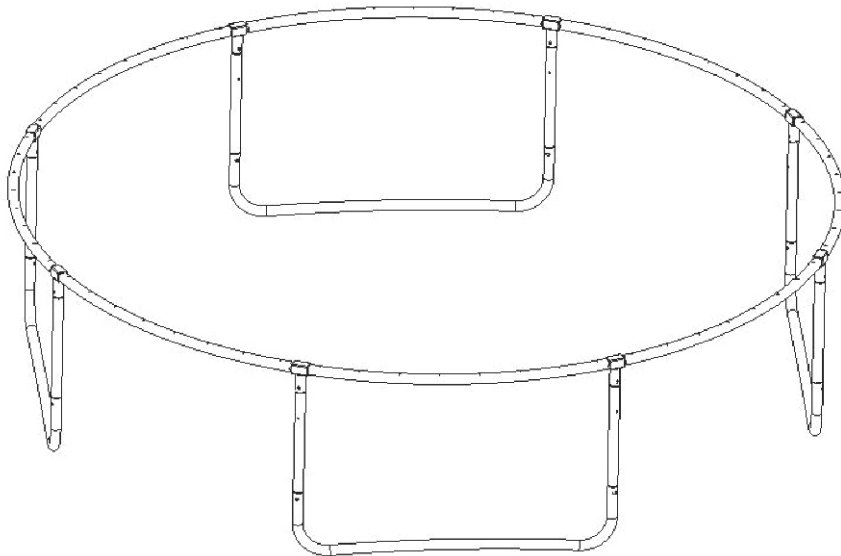

**STEP 5.**

Layout the Jumping Mat (C) inside the frame, and then hook one end of the spring (D) to the V-ring sewn to the jumping mat, and another end to slot in the frame with Spring Fixing Tool (H).

To keep the tension on the mat balanced:

For 14 FT trampoline, install the second springs on the opposite side of the frame. Count 18 v-rings and 18 frame slots in a clockwise direction, and attach a third spring. Then, install the fourth spring on the opposite site of the frame.

For 15FT trampoline, count 18 v-rings and 18 frame slots in a clockwise direction, and attach a second spring, count 36, 54, 72 v-rings and slots to attach the third, fourth and fifth springs.

For 16FT trampoline, install the second springs on the opposite side of the frame. count 27 v-rings and 27 frame slots in a clockwise direction, and attach a third spring. Similarly, install the fourth spring on the opposite side of the frame.

Now you have 4/5 evenly spaced springs attached to the jumping mat and frame.

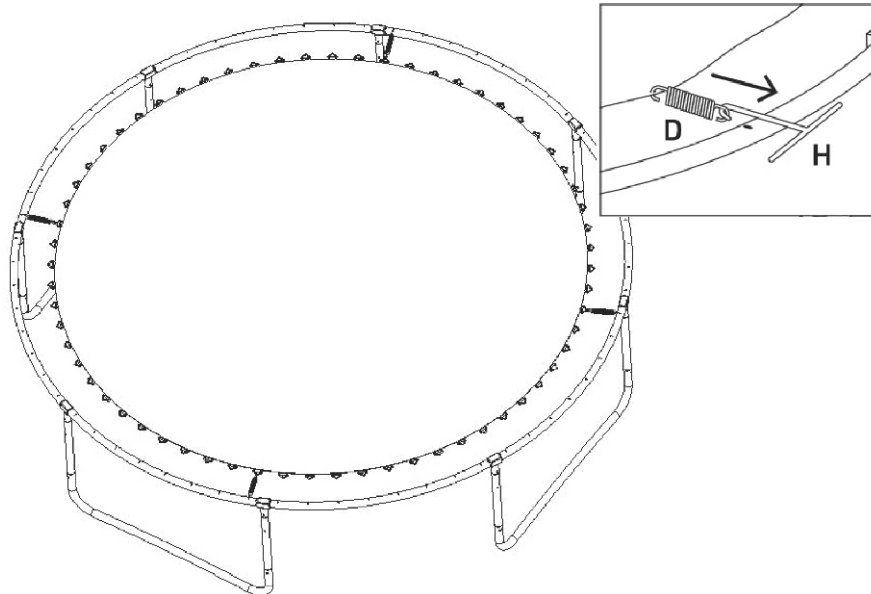

**STEP 6.**

Continue to attach the remaining springs in the middle the previously attached springs until all springs are installed. Do not move the trampoline until assembly is complete.

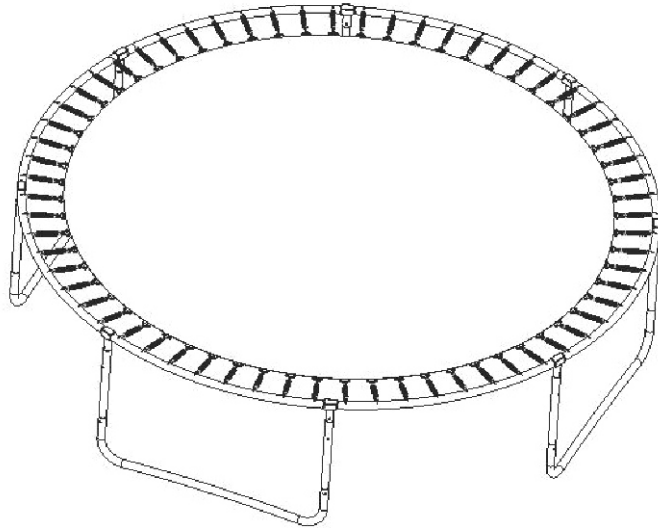

STEP 7. Cover the springs with Cover Pad (B).

**NOTE:** Secure the pad to the springs with the elastic straps.

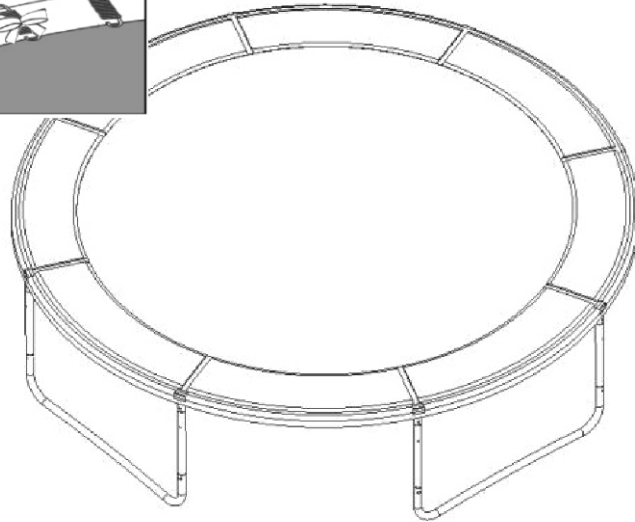
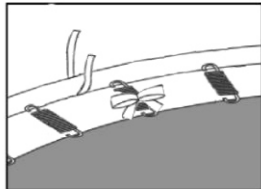

**ENCLOSURE PARTS LIST**

ITEM	SPARE PARTS	14FT	15FT	16FT
J1	RING CLAMP	6	10	12
J2	STRAIGHT CLAMP	6	10	12
K	TOP FITTING	6	10	12
L	WRENCH	1	1	1
M	UPPER POLE	6	10	12
N	LOWER POLE (with 1 hole)	6	10	12
O	ENCLOSURE NET	1	1	1

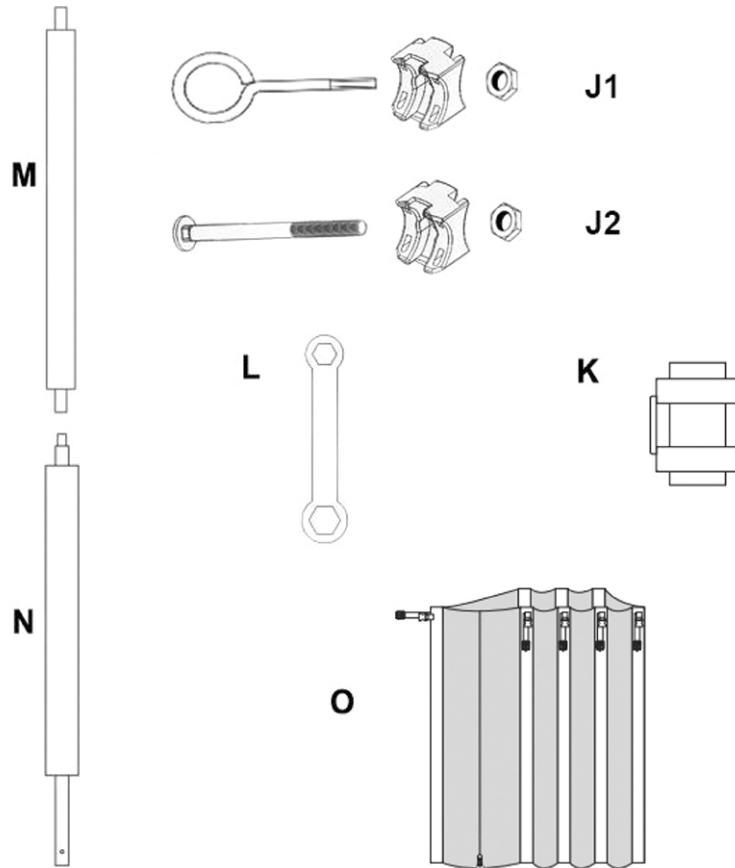

**STEP 1.**

Position the Upper Poles (M) and Lower Poles (N) as below.

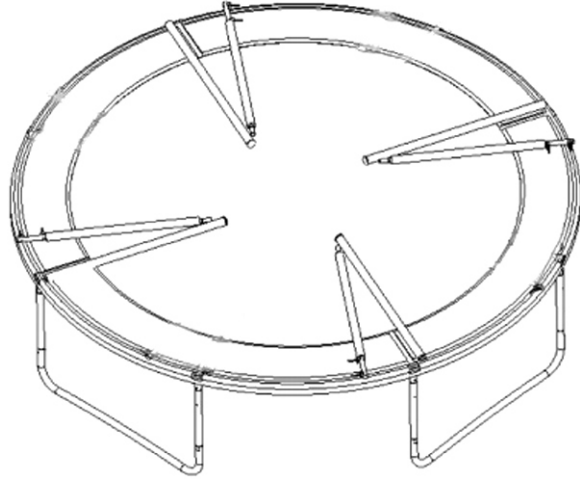

**STEP 2.**

Attach the Lower Poles (N) to the frame of trampoline with the Clamp (J1&J2, J1 for the upper hole, J2 for lower hole), and secure the nut with Wrench (L)

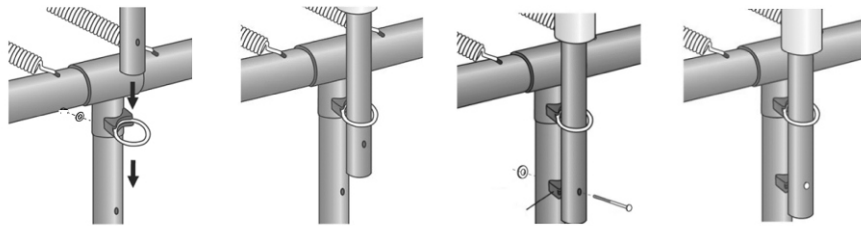

**STEP 3.**

Once all of the lower poles have been assembled, your trampoline should look like the picture below.

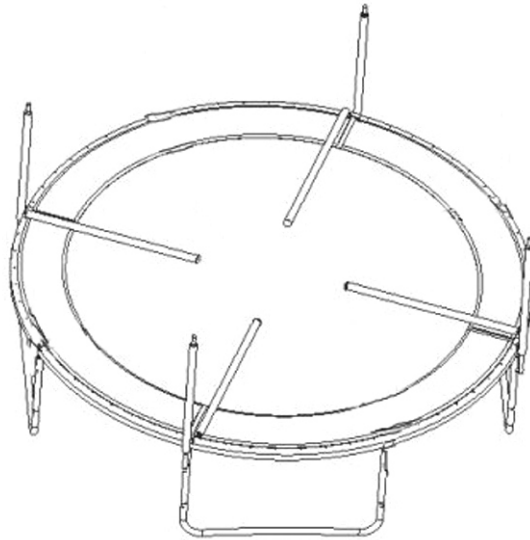

**STEP 4.**

Fit the Top fitting(K) into the Upper Poles(M), then pull the belt which on the top of Enclosure Net(O) into the Top fitting(K) and button them together.

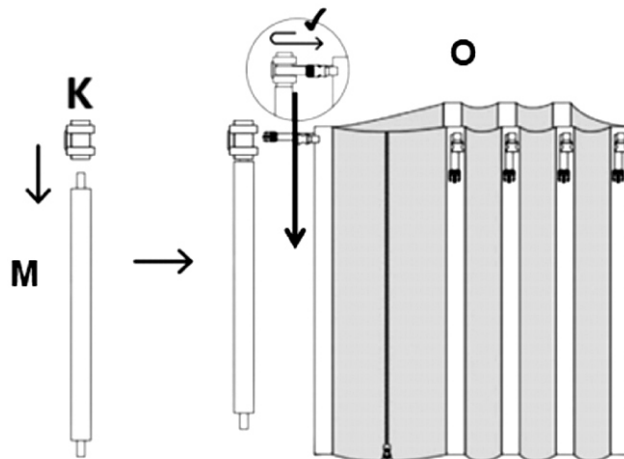

**STEP 5.**

To secure the bottom of the Enclosure Net(O), use the Black String to attach the Enclosure Net to the Jump Mat, by sliding the string through the hole in the net then looping through the nearest V-Ring slot, and hook to an adjacent V-Ring as shown. Repeat this until ends meet in a knot securely on each V-Ring.

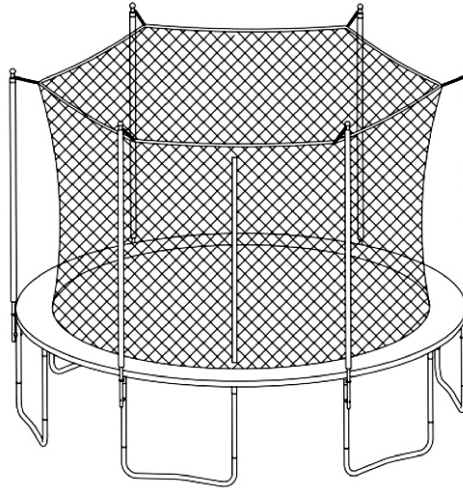
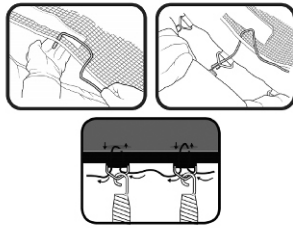

# Congratulations!

## You're ready to JUMP!

### MAINTENANCE

Although your trampoline does not require any particular maintenance, a few precautions are necessary when not in use.

- The trampoline must be kept dry as much as possible. It is therefore best to cover it with a protective cover after each use or dismantle it and store it in a dry and sheltered location when not in use.
- Regularly inspect your trampoline for any defects or premature wear.
- Your trampoline was made by an anti-rust treatment. However, if traces of rust appear following prolonged exposure, it is recommended to attend to these immediately with regular anti-rust treatment.
- If parts are missing or damaged, directly contact our customer service.
- When dismantling your trampoline, follow the assembly instructions above in reverse.

## BASIC TECHNIQUES

### The basic bounce

- Start in an upright position.
- Swing your arms forward in a circular motion.
- After gaining momentum, bring together the tips of your feet pointing downwards while in the air.

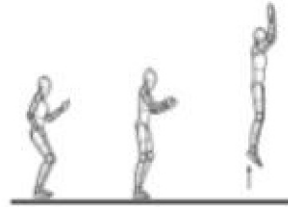

### Cushioning/slowing down

- Users may lose their balance. The cushioning technique allows balance to be quickly regained.
- Start with a normal jump.
- When you come into contact with the mat, bend your knees to cushion the bounce.

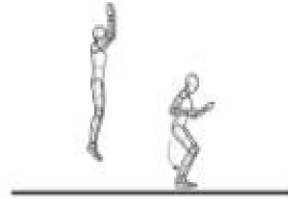

### The hand and knee drop

- Start with a basic bounce.
- Land on your hands and knees, with your back straight.
- Concentrate on landing evenly on the four contact points, rather than on the height of the jump.



### Seat drop

- Land in a seated position, with your hands on the mat.
- Return to the basic position by pushing with your hands.

