

Assembly Instruction

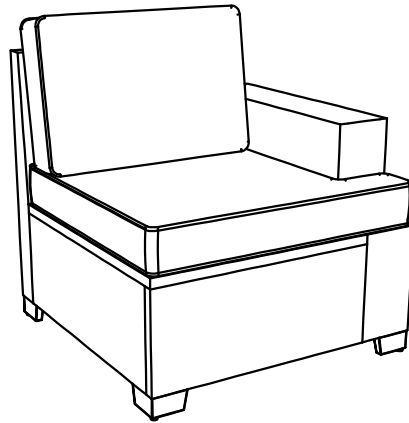











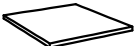

Advice:

1. Power tools are suggested to be used during installation.
2. More than one person may be required to assemble this product.
3. The best advice is not tightening up any screws until the whole piece is assembled. If having difficulty aligning holes, loosen the screws already installed and readjust the armrest.
4. To avoid mess-up or mismatch, please use the hardware of each box to install the furniture in the same box.

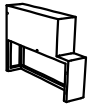

Left Arm Sofa

Parts List

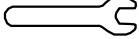
NO.	Picture	Description	QTY	F		Fastener Clip	2
LA-A		Sofa Back	1	W		Screw (M6*30)	8
LA-B		Sofa Seat	1	V		Screw (M6*35)	6
LA-C		Front Panel	1	T		Screw (M6*45)	1
LA-D		Side Panel	1	S		Screw (M6*60)	9
LA-E		Left Arm	1	N		Washer (M6)	25
LA-F		Sofa Leg	4	M		Nut (M6)	9
LA-G		Back Cushion	1	L		Allen Key	1
LA-H		Seat Cushion	1	J		Wrench (M6)	1

STEP 1

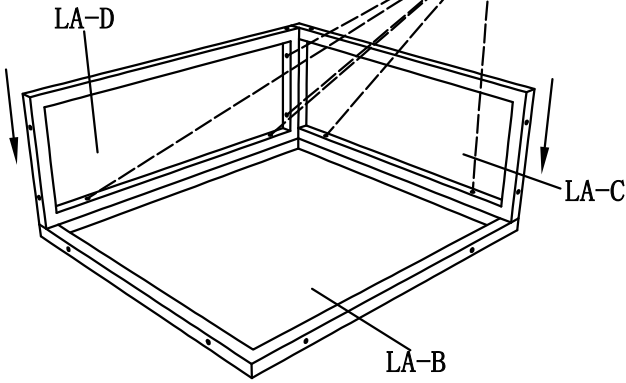
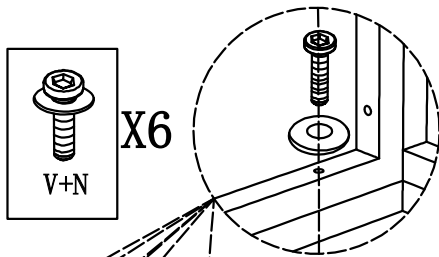

STEP 2

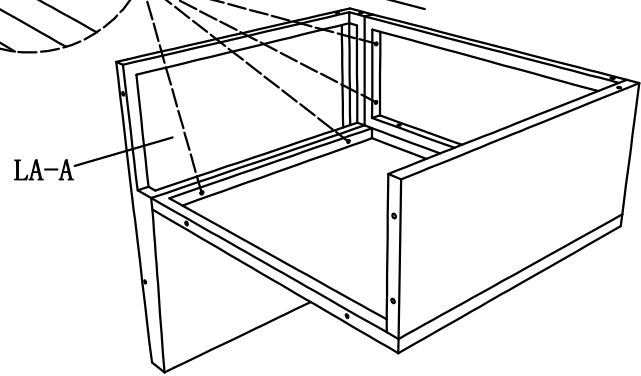
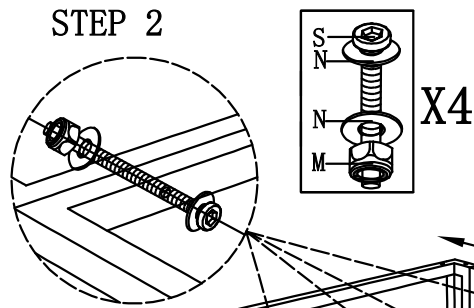

The best advice is not tightening up any screws until the whole piece is assembled.

STEP 3

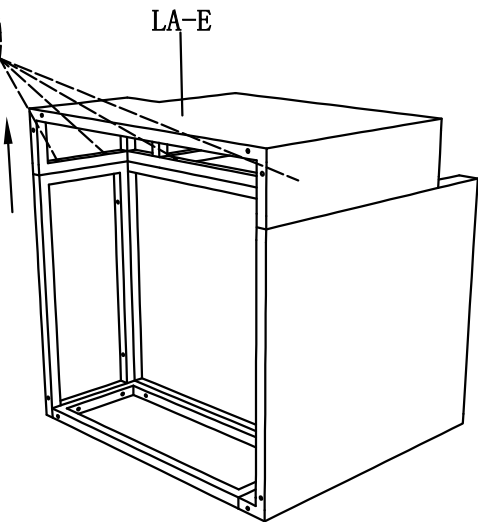
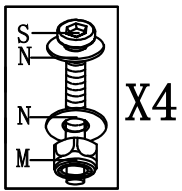
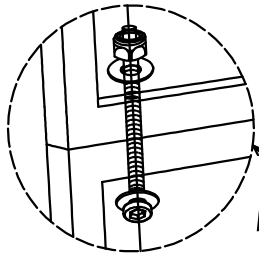

STEP 4

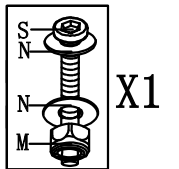
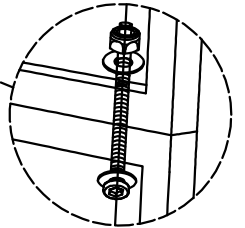
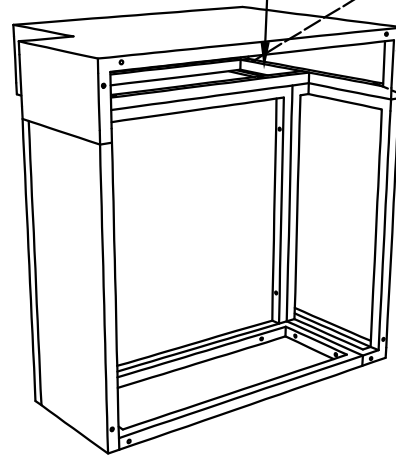
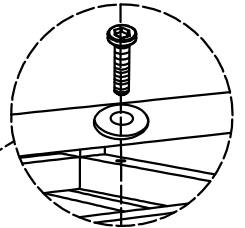
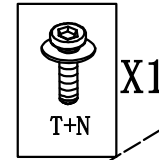

STEP 5

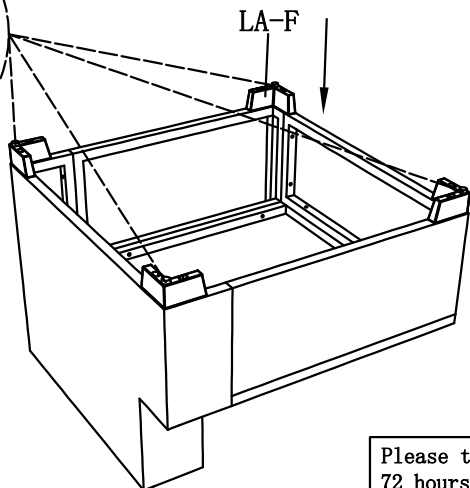
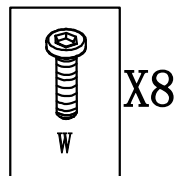
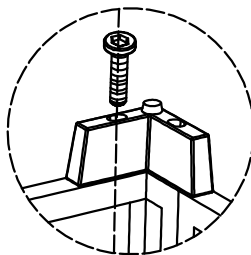

FINISH

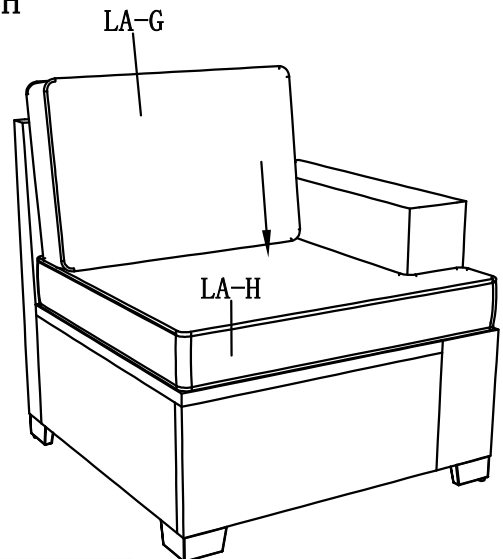

Please tap the cushions and wait 48 to 72 hours to fully rebound

Assembly Instruction





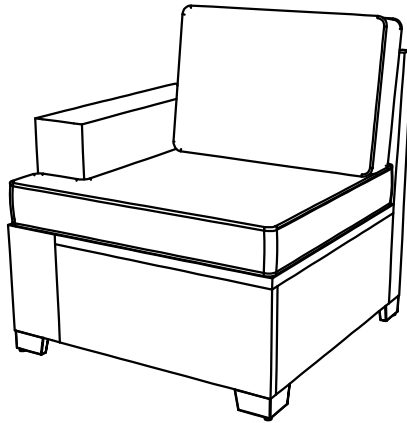





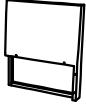

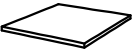

Advice:

1. Power tools are suggested to be used during installation.
2. More than one person may be required to assemble this product.
3. The best advice is not tightening up any screws until the whole piece is assembled. If having difficulty aligning holes, loosen the screws already installed and readjust the armrest.
4. To avoid mess-up or mismatch, please use the hardware of each box to install the furniture in the same box.

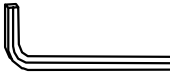

Right Arm Sofa

Parts List

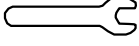
NO.	Picture	Description	QTY	F		Fastener Clip	2
RA-A		Sofa Back	1	W		Screw (M6*30)	8
RA-B		Sofa Seat	1	V		Screw (M6*35)	6
RA-C		Front Panel	1	T		Screw (M6*45)	1
RA-D		Right Arm	1	S		Screw (M6*60)	9
RA-E		Side Panel	1	N		Washer (M6)	25
RA-F		Sofa Leg	4	M		Nut (M6)	9
RA-G		Back Cushion	1	L		Allen Key	1
RA-H		Seat Cushion	1	J		Wrench (M6)	1

STEP 1

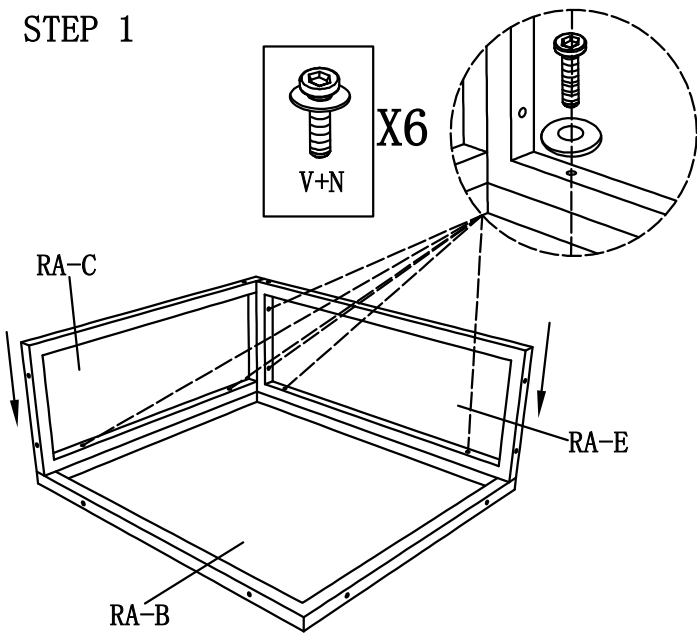

STEP 2

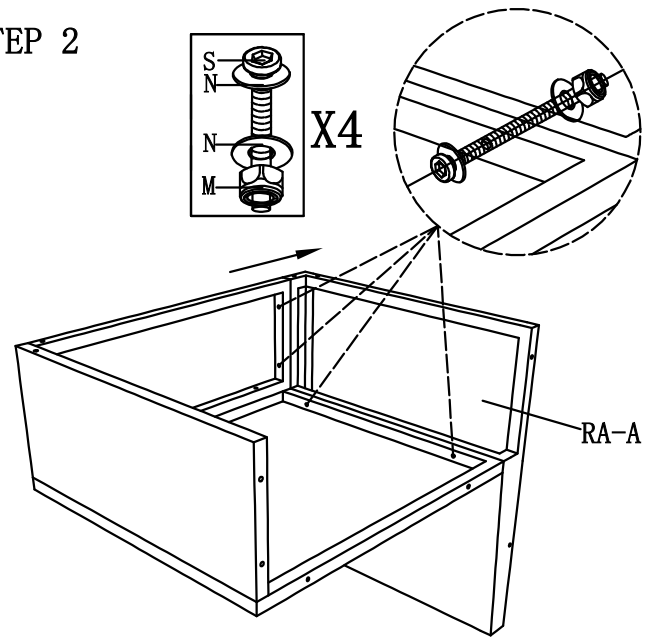

The best advice is not tightening up any screws until the whole piece is assembled.

STEP 3

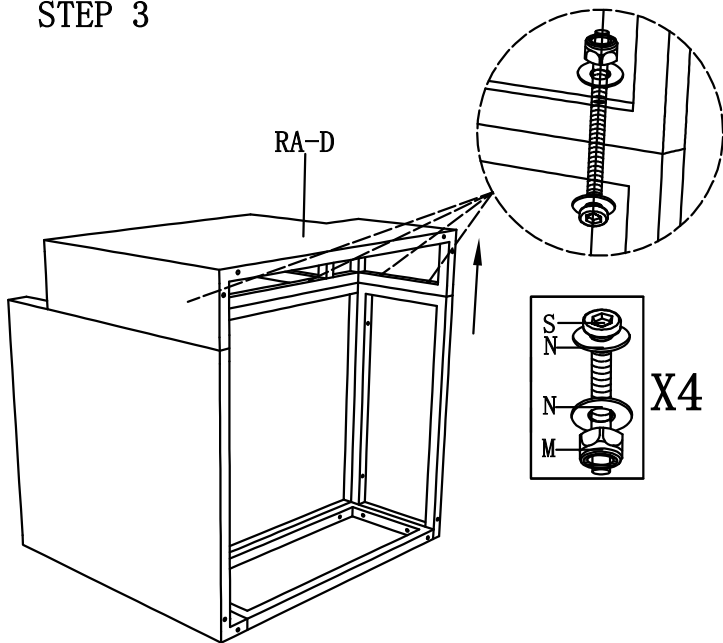

STEP 4

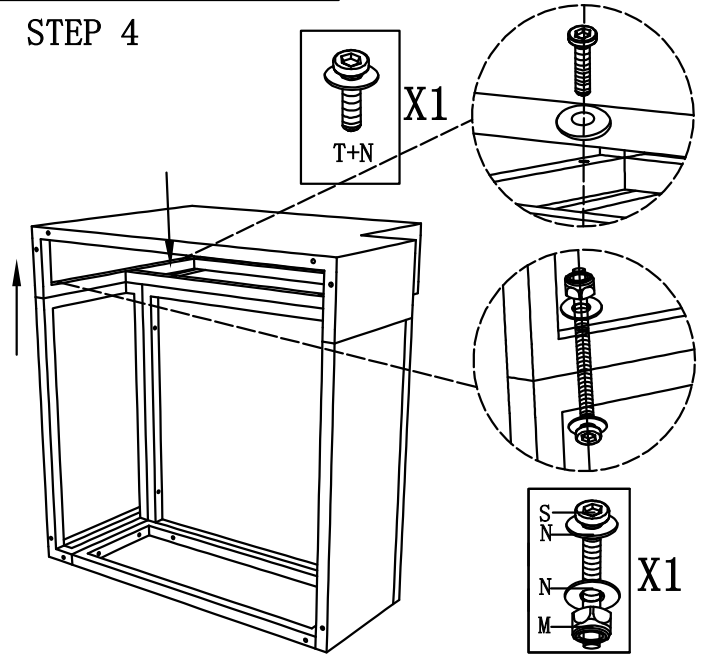

STEP 5

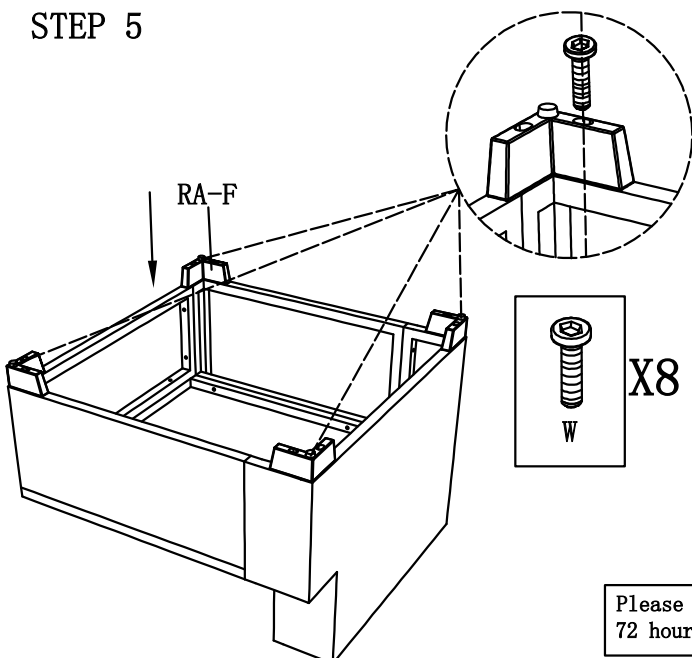

FINISH

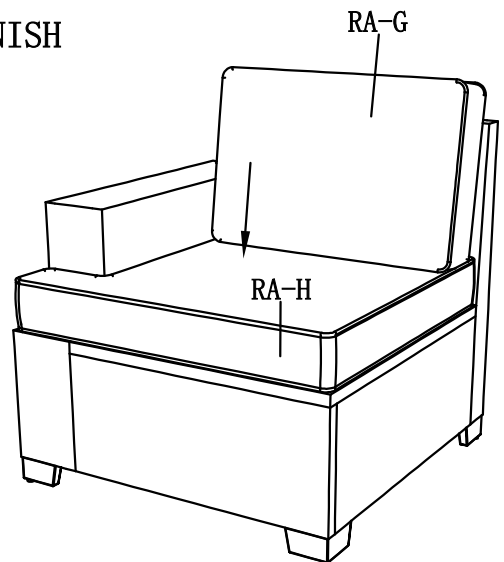

Please tap the cushions and wait 48 to 72 hours to fully rebound

Assembly Instruction





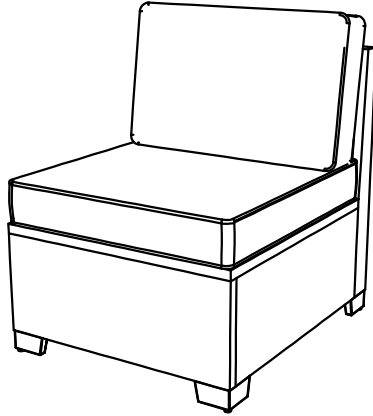









Advice:

1. Power tools are suggested to be used during installation.
2. More than one person may be required to assemble this product.
3. The best advice is not tightening up any screws until the whole piece is assembled. If having difficulty aligning holes, loosen the screws already installed and readjust the armrest.
4. To avoid mess-up or mismatch, please use the hardware of each box to install the furniture in the same box.



Armless Sofa #1

Parts List

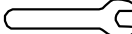
NO.	Picture	Description	QTY	F		Fastener Clip	2
AS-A		Sofa Back	1	W		Screw (M6*30)	8
AS-B		Sofa Seat	1	V		Screw (M6*35)	10
AS-C		Front Panel	1	S		Screw (M6*60)	6
AS-E		Side Panel	2	N		Washer (M6)	22
AS-F		Sofa Leg	4	M		Nut (M6)	6
AS-G		Back Cushion	1	L		Allen Key	1
AS-H		Seat Cushion	1	J		Wrench (M6)	1

STEP 1

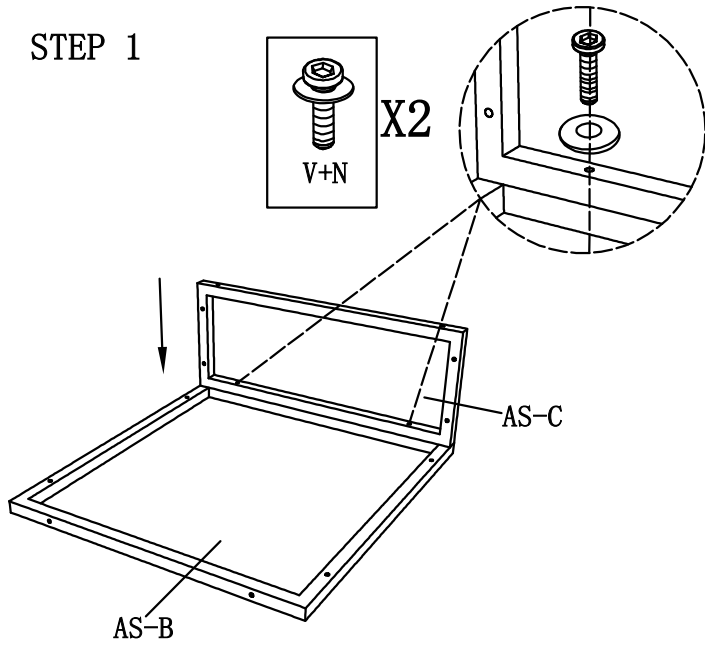

STEP 2

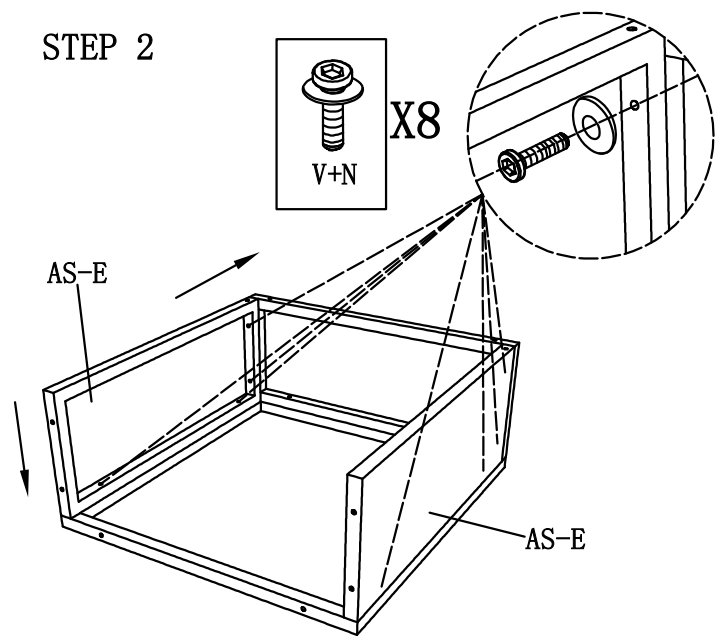

The best advice is not tightening up any screws until the whole piece is assembled.

STEP 3

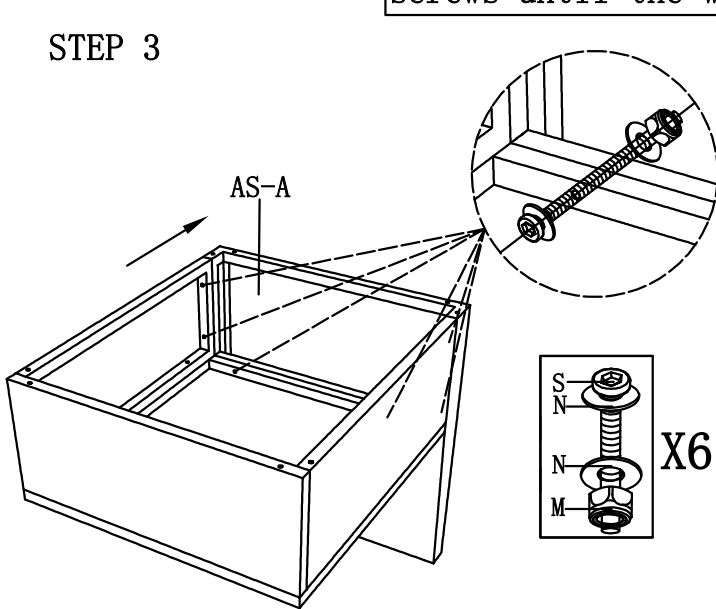

STEP 4

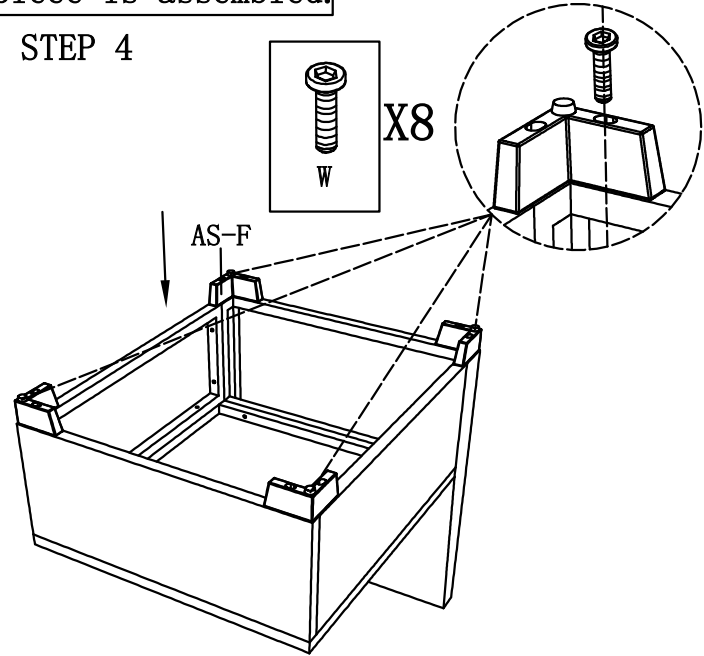

FINISH

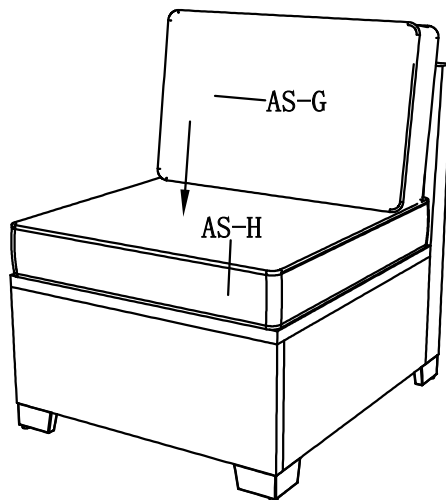

Please tap the cushions and wait 48 to 72 hours to fully rebound

Assembly Instruction

Advice:

1. Power tools are suggested to be used during installation.
2. More than one person may be required to assemble this product.
3. The best advice is not tightening up any screws until the whole piece is assembled. If having difficulty aligning holes, loosen the screws already installed and readjust the armrest.
4. To avoid mess-up or mismatch, please use the hardware of each box to install the furniture in the same box.

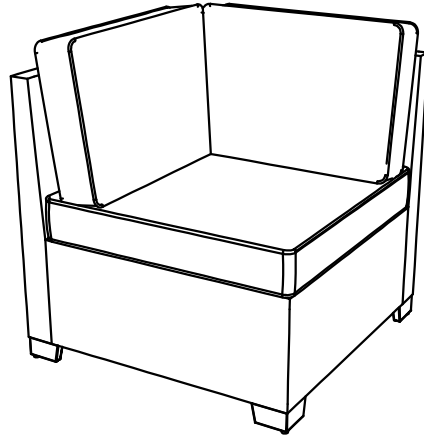

Corner Sofa

Parts List

NO.	Picture	Description	QTY	F	Image	Description	QTY
				F		Fastener Clip	2
CS-A		Sofa Back	1	W		Screw (M6*30)	8
CS-B		Sofa Seat	1	V		Screw (M6*35)	4
CS-D		Long Sofa Back	1	S		Screw (M6*60)	11
CS-E		Side Panel	1	P		Screw (M6*95)	1
CS-F		Sofa Leg	4	N		Washer (M6)	27
CS-G		Back Cushion	1	M		Nut (M6)	11
CS-H		Seat Cushion	1	L		Allen Key	1
CS-I		Long Back Cushion	1	J		Wrench (M6)	1

STEP 1

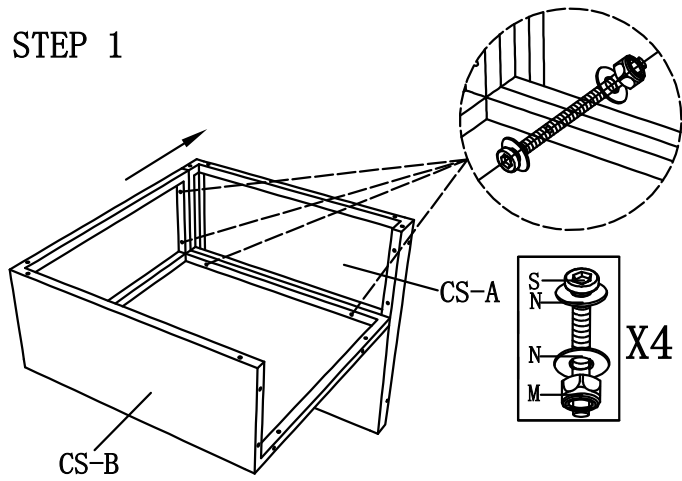

STEP 2

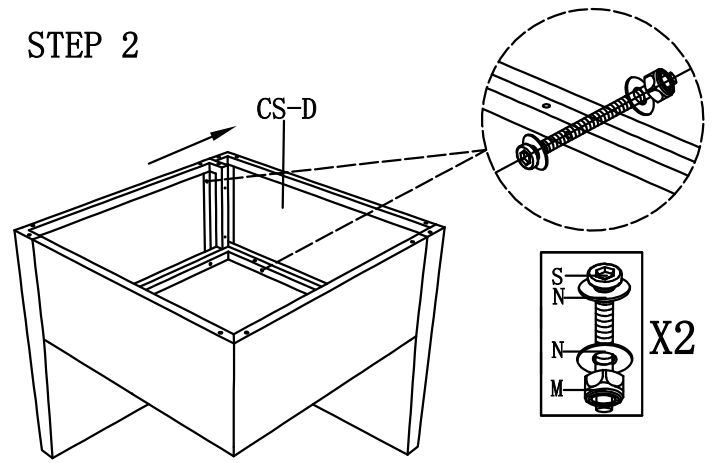

The best advice is not tightening up any screws until the whole piece is assembled.

STEP 3

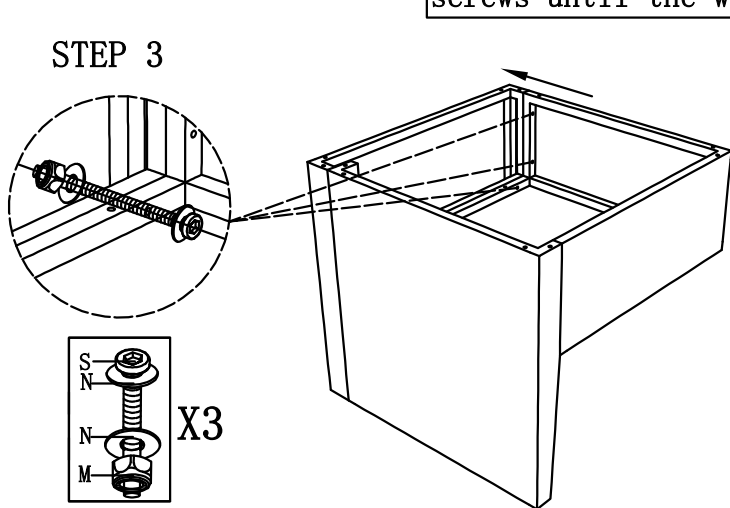

STEP 4

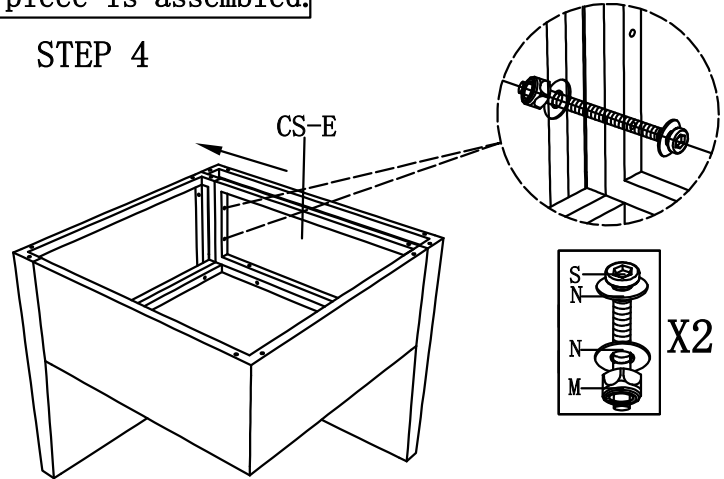

STEP 5

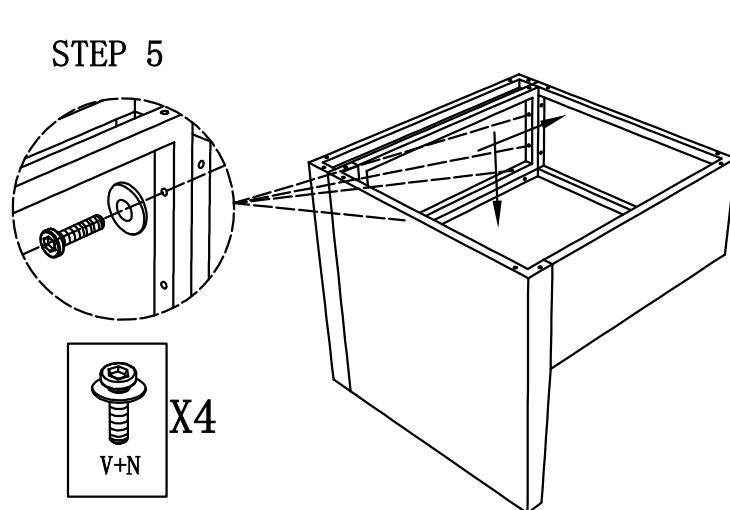

STEP 6

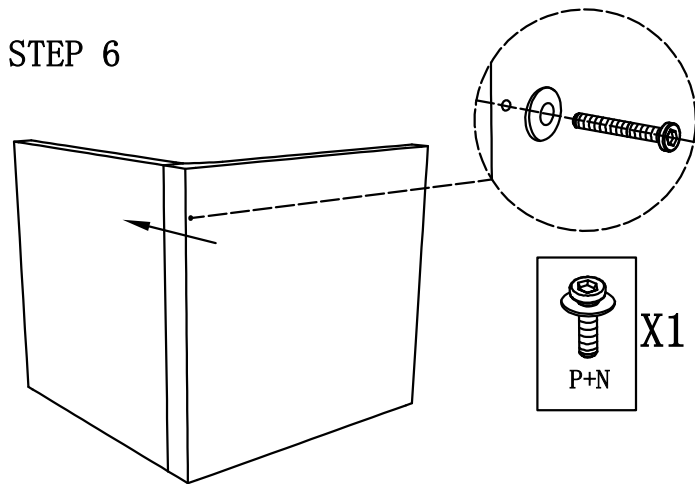

STEP 7

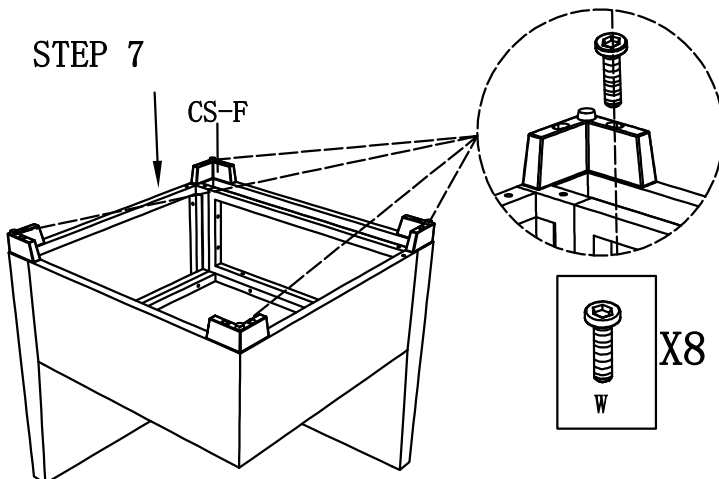

FINISH

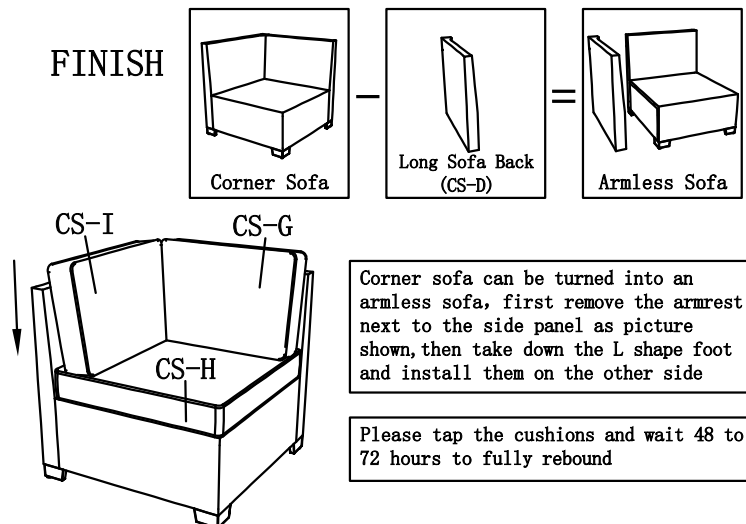

Corner sofa can be turned into an armless sofa, first remove the armrest next to the side panel as picture shown, then take down the L shape foot and install them on the other side

Please tap the cushions and wait 48 to 72 hours to fully rebound

Assembly Instruction





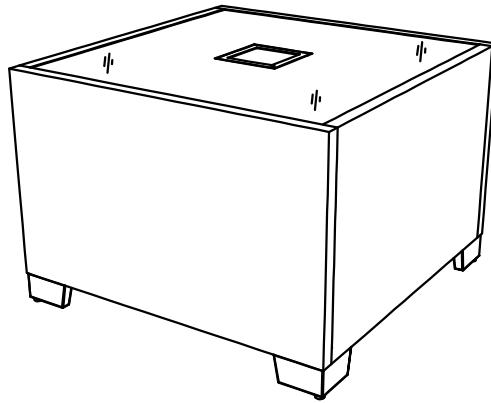





Advice:

1. Power tools are suggested to be used during installation.
2. More than one person may be required to assemble this product.
3. The best advice is not tightening up any screws until the whole piece is assembled. If having difficulty aligning holes, loosen the screws already installed and readjust the armrest.
4. To avoid mess-up or mismatch, please use the hardware of each box to install the furniture in the same box.

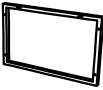

Table

Parts List

NO.	Picture	Description	QTY	NO.	Picture	Description	QTY
T-A		Solar Lamp	1	X		Screw (M6*25)	4
T-B		Glass Top	1	W		Screw (M6*30)	8
T-C		Support Bracket	1	V		Screw (M6*35)	8
T-D		Long Side Panels	2	N		Washer (M6)	12
T-E		Short Side Panels	2	L		Allen Key	1
T-F		Sofa Leg	4				

STEP 1

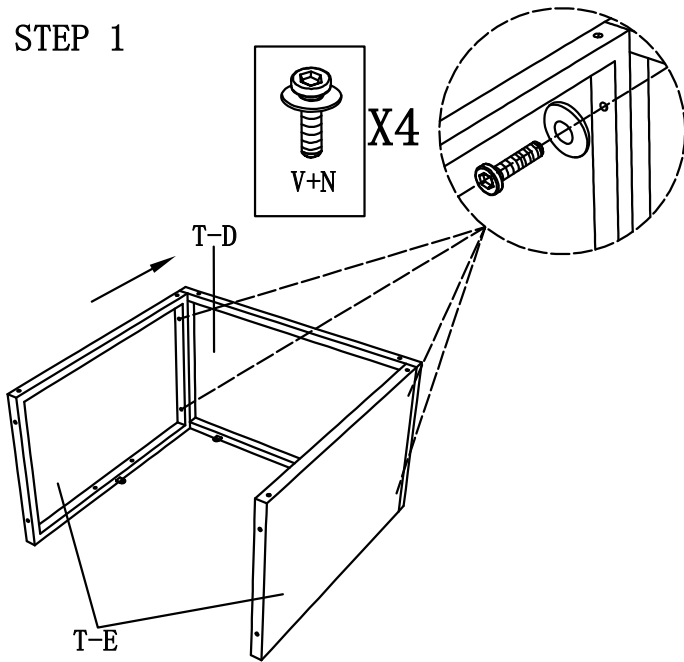

STEP 2

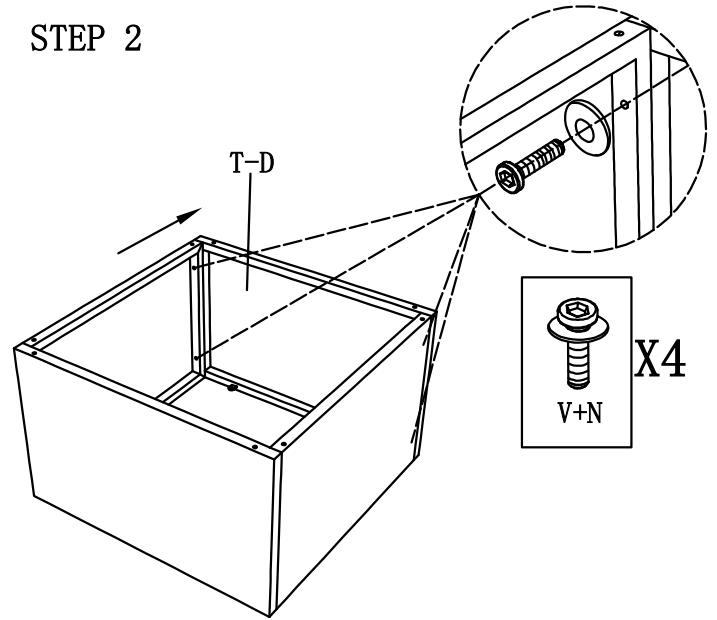

The best advice is not tightening up any screws until the whole piece is assembled.

STEP 3

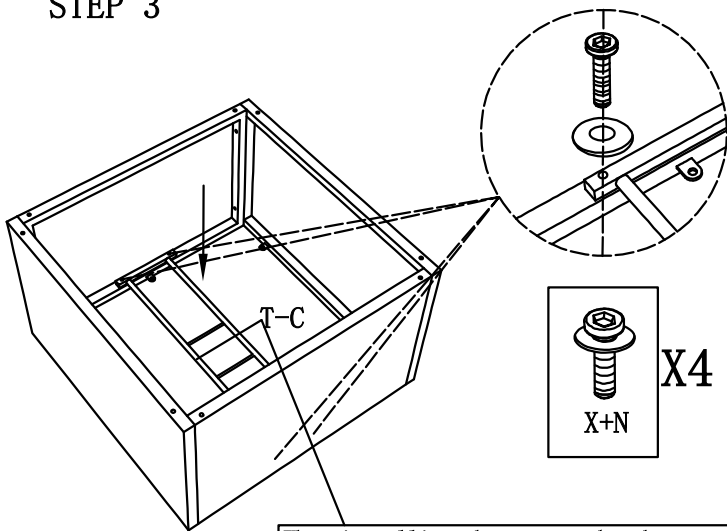

When installing the support bracket, pay attention to the direction. The two bulged small rod should face to the glass, so that the solar lamp and the glass can be parallel.

STEP 4

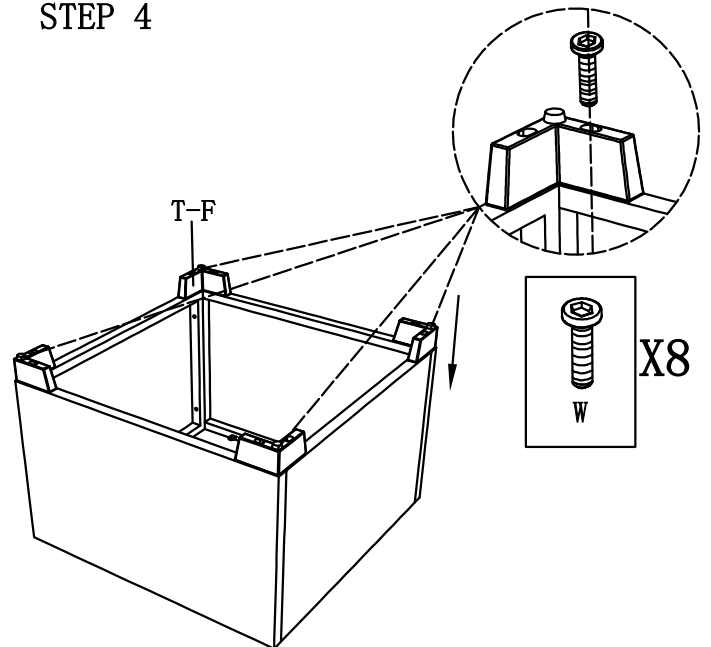

STEP 5

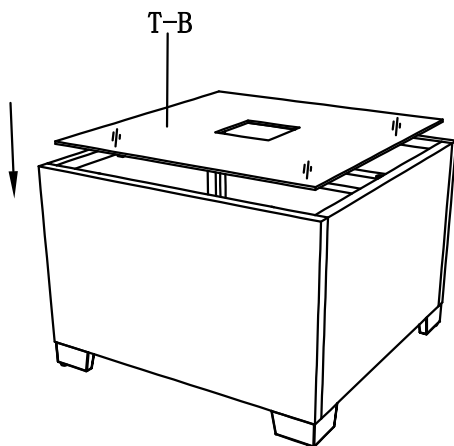

FINISH

