

ASSEMBLY INSTRUCTION

DINING TABLE

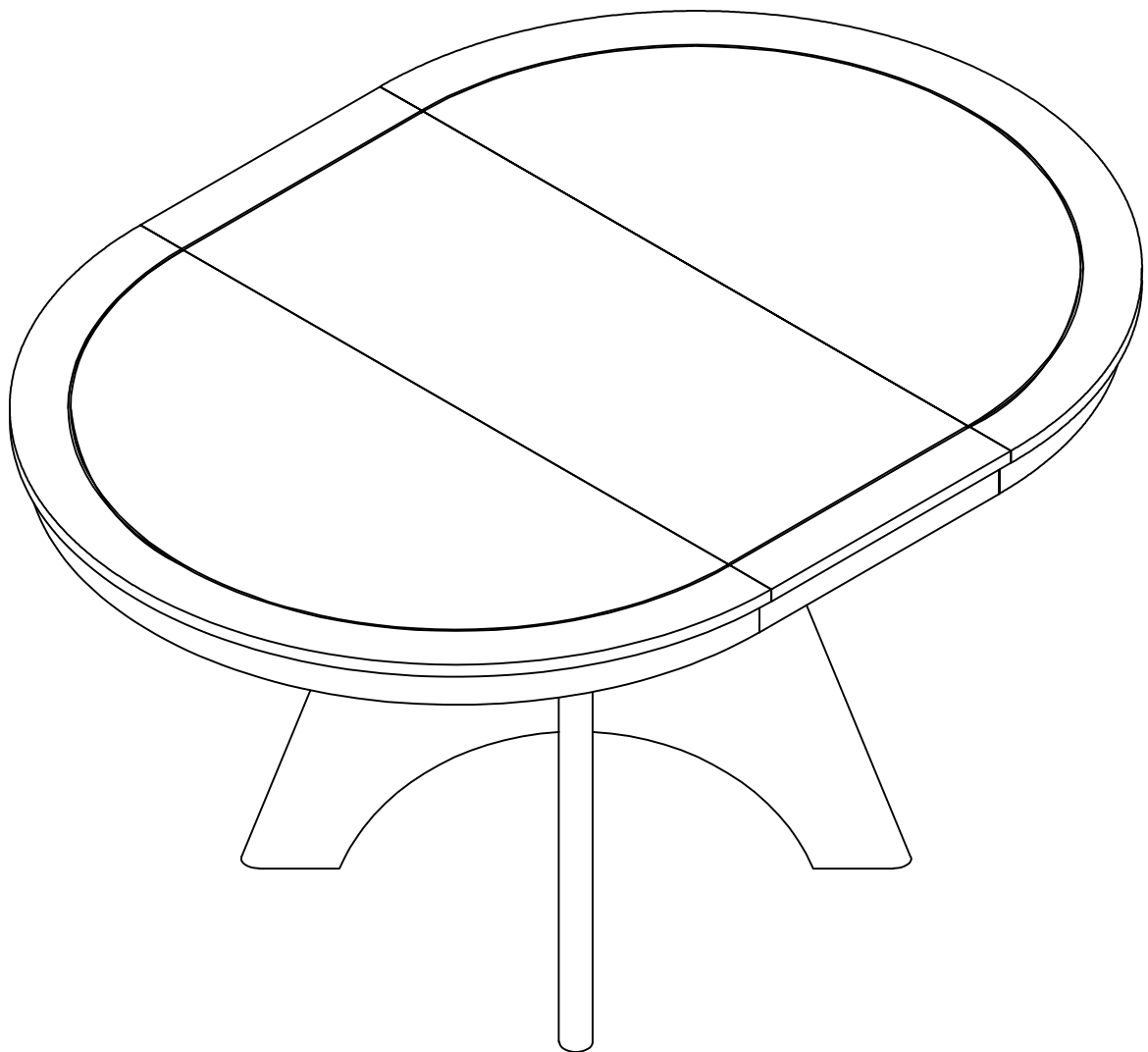







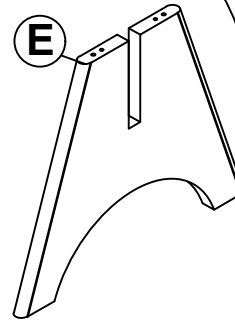
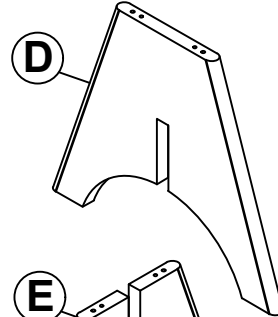
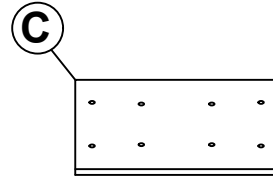
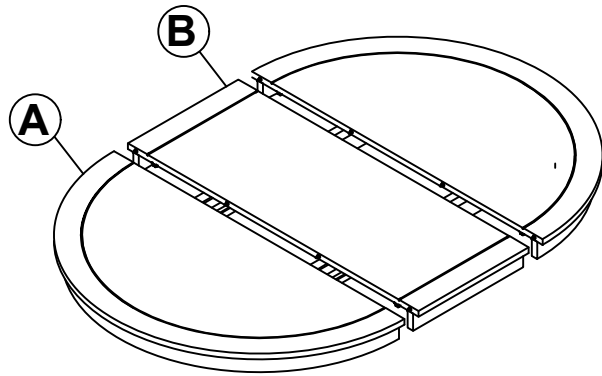

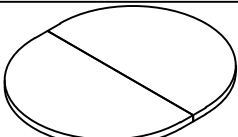
IMPORTANT NOTE :

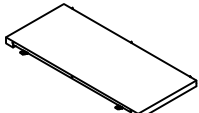
- ① PLACE ALL PARTS ON A CLEAN AND SMOOTH SURFACE SUCH AS A RUG OR CARPET TO AVOID THE PARTS FROM BEING SCRATCHED.
- ② BEFORE YOU BEGIN , KINDLY FOLLOW THE ASSEMBLY INSTRUCTIONS STEP BY STEP.
- ③ DO NOT TIGHTEN ALL SCREWS AND BOLTS UNTIL THE TABLE IS FULLY SET-UP

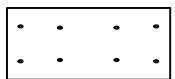
Detail view



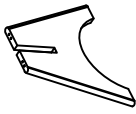
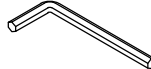



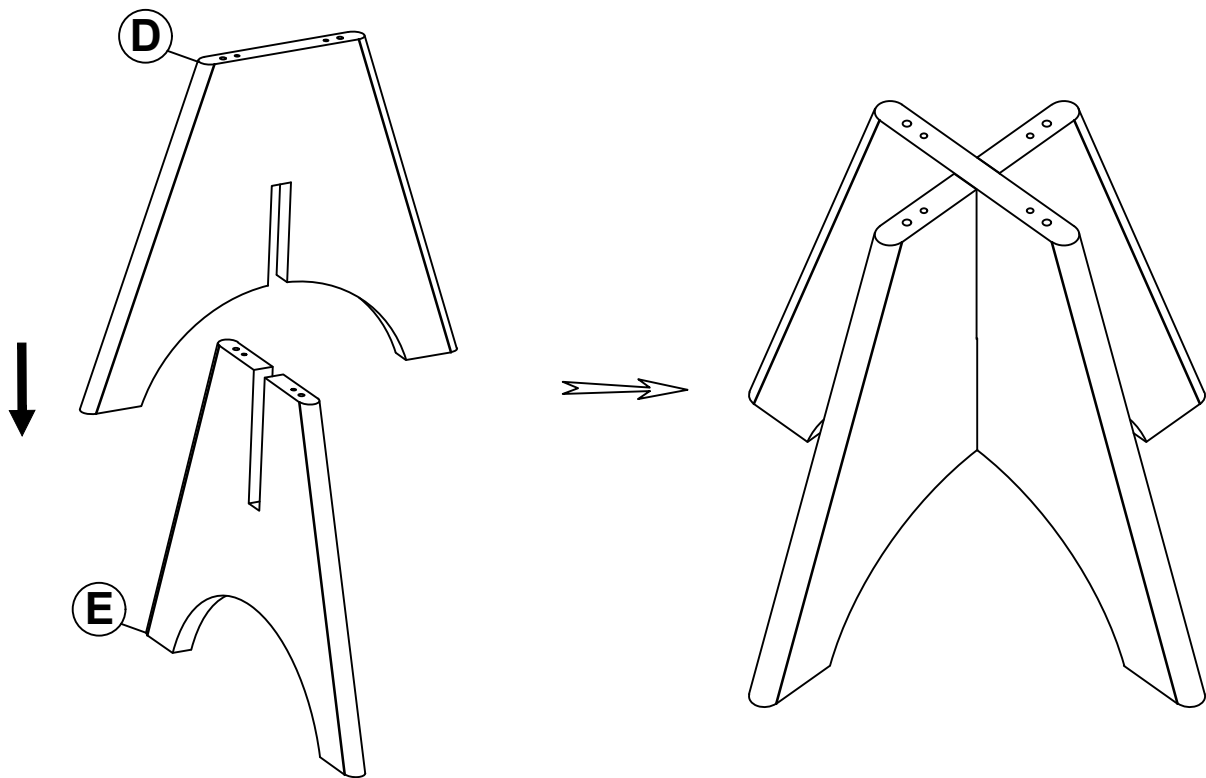

Part List		Hardware List	
A  Table Top (1pc)	1  Ø5/16" x 40mm Bolt (8pcs)		
B  Center Leaf (1pc)	2  Ø5/16" x 13mm x 1.5mm Spring Washer (8pcs)		
C  Link Board(1pc)	3  Ø5/16" x 19mm x 1.5mm Flat Washer (8pcs)		
D  Table Middle Leg (1pc)	4  Ø8 x 30mm Wooden Dowel (4pcs)		
E  Table Legs (1pcs)	5  4 x 58mm Allen key (1pc)		

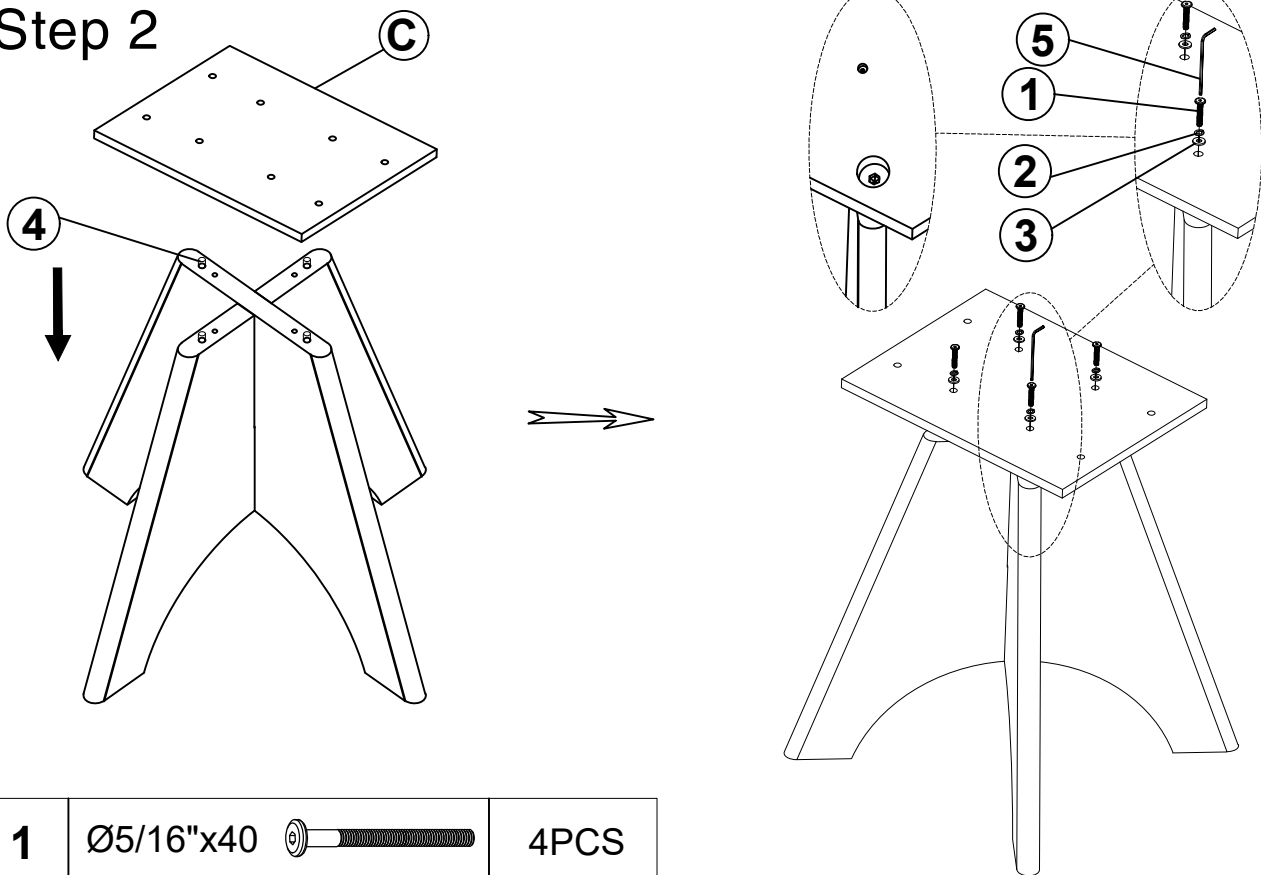
Step 1







Step 2

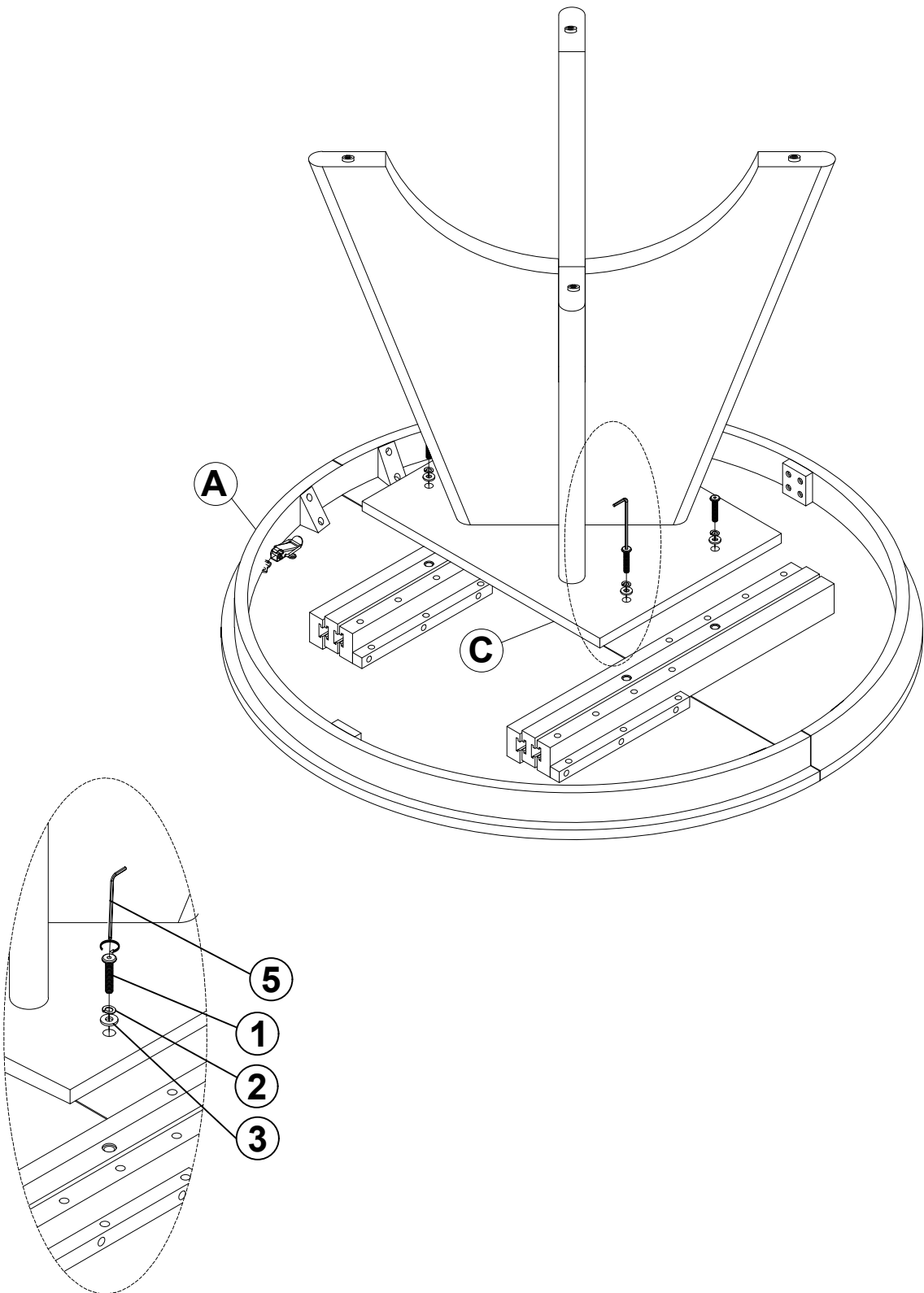

1	Ø5/16"x40		4PCS				
2	Ø5/16"x13x1.5		4PCS	3	Ø5/16"x19x1.5		4PCS
4	Ø8x30		4PCS	5	4x58		1PC

Step 3



1	Ø5/16"x40 	4PCS	4	Ø5/16"x19x1.5 	4PCS
3	Ø5/16"x13x1.5 	4PCS	6	4x58 	1PC

Step 4

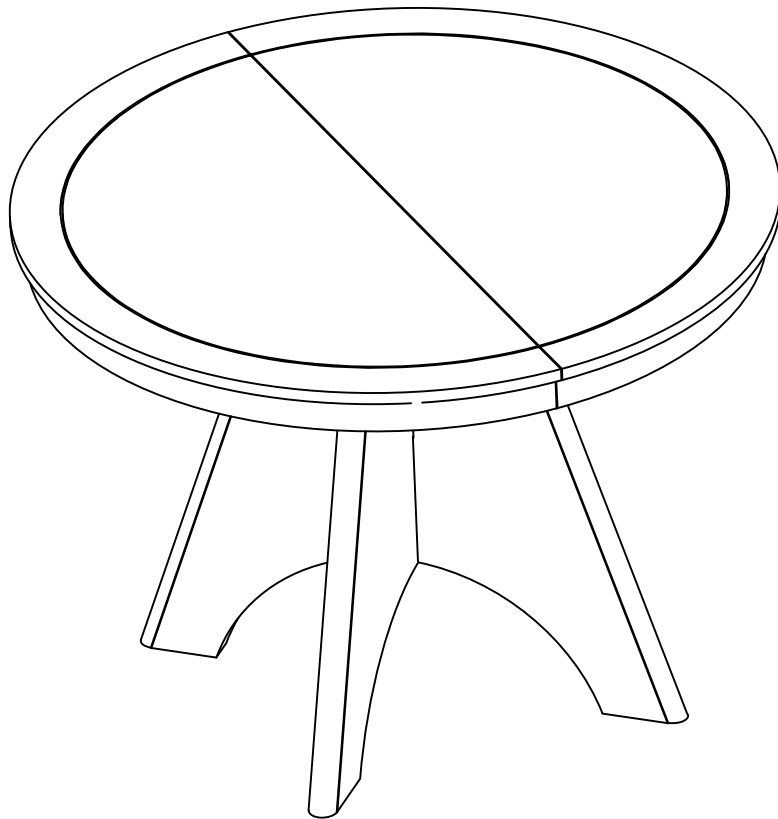
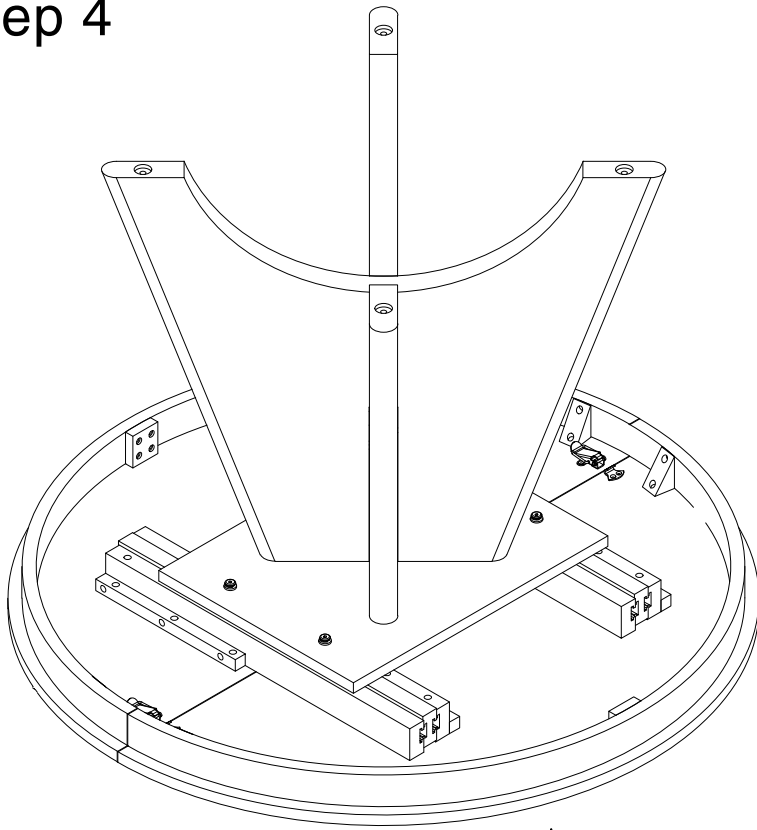

Step 5

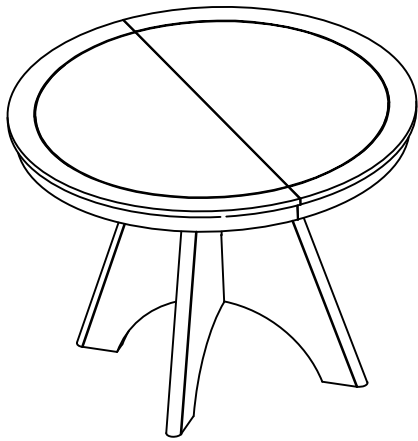

Unlock in these positions and pull the table top to either side.

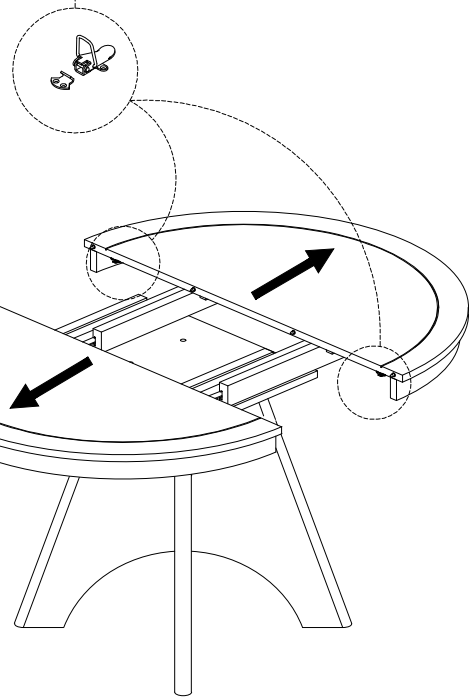

Place B in this position and align the drill holes accordingly then push the two table tops together.

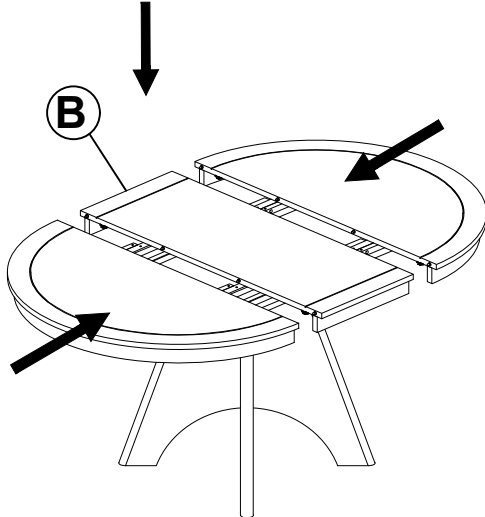

Hardware lock these positions.

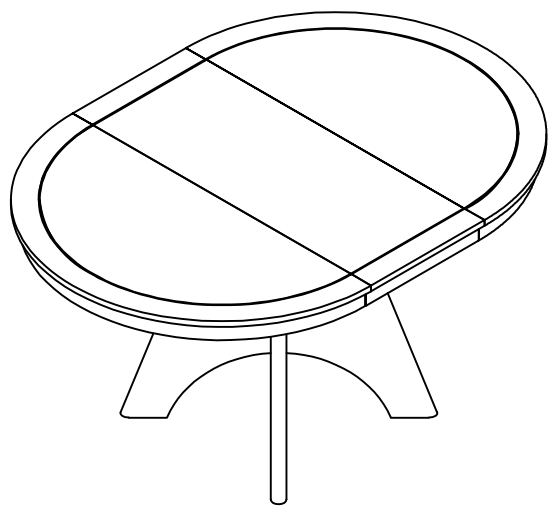
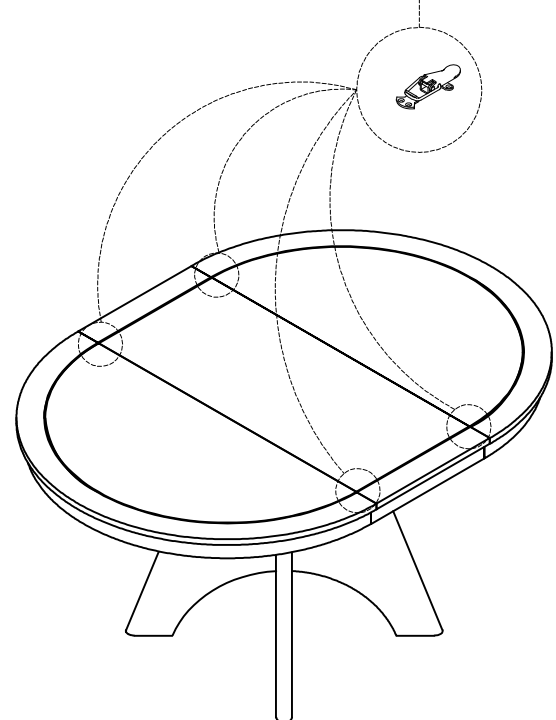

Completed