

ASSEMBLY GUIDE
GUIDE D'ASSEMBLAGE
INSTRUCCIONES DE ENSAMBLAJE

Lateral File
Classeur latéral
Archivador lateral



△ NOTE:

If there are parts missing from your order or if your product was damaged during shipping, PLEASE CONTACT US DIRECTLY.

△ NOTE :

S'il vous manque des pièces ou si votre meuble a été endommagé pendant le transport, VEUILLEZ NOUS CONTACTER DIRECTEMENT.

△ NOTA:

En caso de piezas faltantes o si su producto fue dañado durante el envío, POR FAVOR CONTÁCTENOS DIRECTAMENTE.

IMPORTANT SAFETY INFORMATION



PLEASE READ WARNINGS

Improper use can cause safety hazards, or damage to your furniture and household items.

Warning	Do	Don't	Why it's important
Serious injury may occur.	<ul style="list-style-type: none">Assemble following all instructions using all indicated parts and hardware provided.Verify furniture is stable on it's own. Place heaviest items in the lower drawers.Always load the bottom drawer first. Check before using that only one drawer opens at a time.Evenly distribute files front to back. If so equipped, extend front levelers 1/4" more than rear levelers so unit tilts slightly rearward."	<ul style="list-style-type: none">Do not load with a television or other heavy equipment.Do not exceed the maximum load limits stated in the instructions.Do not allow children to stand, climb, or hang on furniture."	<ul style="list-style-type: none">Improper assembly, use or loading can lead to product instability, tip-over or collapse.
Serious injury may occur.	<ul style="list-style-type: none">Properly install and maintain the anti-tip mechanism.		<ul style="list-style-type: none">The anti-tip mechanism prevents more than one drawer from being opened at once which may lead to instability or product tip-over.

Caution	Do	Don't	Why it's important
Injury may occur.	<ul style="list-style-type: none">Unload unit prior to moving starting with top drawer first.	<ul style="list-style-type: none">Do not move unit when loaded.	<ul style="list-style-type: none">Loaded units are heavy and are not designed to be moved when loaded.

IMPORTANT SAFETY INFORMATION



PLEASE READ WARNINGS

Improper use can cause safety hazards, or damage to your furniture and household items.

Advertencia	Hacer	No	Por qué es importante
Se pueden producir lesiones graves.	<ul style="list-style-type: none">• Ensamble siguiendo todas las instrucciones utilizando todas las piezas y ferretería indicados provistos.• Verifique que los muebles sean estables por sí mismos.• Coloque los artículos más pesados en los cajones inferiores.• Siempre cargue primero el cajón inferior.• Compruebe antes de usar que solo se abre un cajón a la vez.• Distribuya uniformemente los archivos de adelante hacia atrás. Si está equipado, extienda los niveladores delanteros 1/4 " "más que los niveladores traseros para que la unidad se incline ligeramente hacia atrás."	<ul style="list-style-type: none">• No cargue con un televisor u otro equipo pesado. No exceda los límites máximos de carga establecidos en las instrucciones.• No permita que los niños se paren, trepen o cuelguen de muebles.	<ul style="list-style-type: none">• El ensamblaje, uso o carga inadecuados pueden provocar inestabilidad del producto, vuelco o colapso.
Se pueden producir lesiones graves.	<ul style="list-style-type: none">• Instale y mantenga adecuadamente el mecanismo antivuelco.		<ul style="list-style-type: none">• El mecanismo antivuelco evita que se abra más de un cajón a la vez, lo que puede provocar inestabilidad o vuelco del producto.

Atención	Hacer	No	Por qué es importante
Se pueden producir lesiones.	<ul style="list-style-type: none">• Descargue la unidad antes de moverla, comenzando primero con el cajón superior.	<ul style="list-style-type: none">• No mueva la unidad cuando esté cargada.	<ul style="list-style-type: none">• Las unidades cargadas son pesadas y no están diseñadas para moverse cuando están cargadas.

IMPORTANT SAFETY INFORMATION



PLEASE READ WARNINGS

Improper use can cause safety hazards, or damage to your furniture and household items.

Avertissement	Faire	Ne le fais pas	Pourquoi c'est important
Des blessures graves peuvent survenir.	<ul style="list-style-type: none">• Assemblez en suivant toutes les instructions en utilisant toutes les pièces et le matériel indiqués fournis.• Vérifiez que les meubles sont stables par eux-mêmes.• Placez les objets les plus lourds dans les tiroirs inférieurs.• Chargez toujours le tiroir inférieur en premier.• Vérifiez avant d'utiliser qu'un seul tiroir s'ouvre à la fois.• Répartissez uniformément les fichiers d'avant en arrière.• Si tel est le cas, déployez les niveleurs avant de 1/4 po de plus que les niveleurs arrière afin que l'appareil s'incline légèrement vers l'arrière.	<ul style="list-style-type: none">• Ne chargez pas avec un téléviseur ou un autre équipement lourd. Ne dépassez pas les limites de charge maximale indiquées dans les instructions.• Ne laissez pas les enfants se tenir debout, grimper ou s'accrocher aux meubles.	<ul style="list-style-type: none">• Un assemblage, une utilisation ou un chargement incorrects peuvent entraîner une instabilité du produit, un renversement ou un effondrement.
Des blessures graves peuvent survenir.	<ul style="list-style-type: none">• Installez et entretenez correctement le mécanisme anti-basculement.		<ul style="list-style-type: none">• Le mécanisme anti-basculement empêche l'ouverture simultanée de plusieurs tiroirs, ce qui peut entraîner une instabilité ou un renversement du produit.

Attention	Faire	Ne le fais pas	Pourquoi c'est important
Des blessures graves peuvent survenir.	<ul style="list-style-type: none">• Déchargez l'unité avant de déplacer en commençant par le tiroir supérieur en premier.	<ul style="list-style-type: none">• Ne déplacez pas l'unité lorsqu'elle est chargée.	<ul style="list-style-type: none">• Les unités chargées sont lourdes et ne sont pas conçues pour être déplacées lorsqu'elles sont chargées.

Parts - Pièces - Piezas

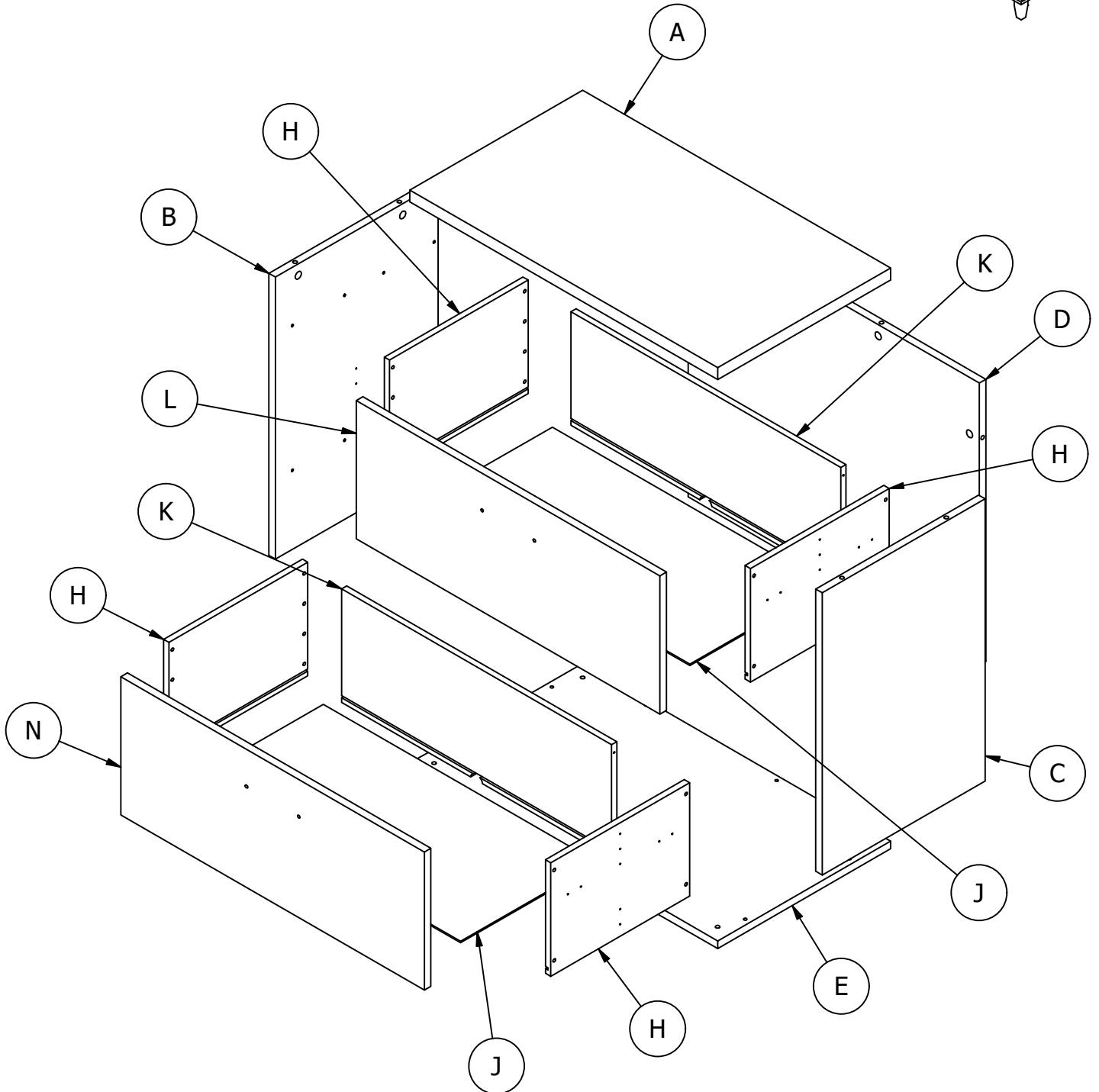
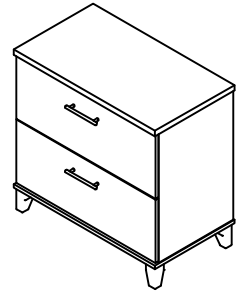

Fasteners - Fixations - Sujetadores

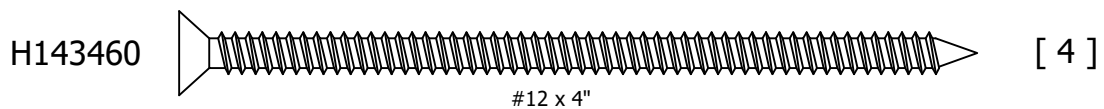
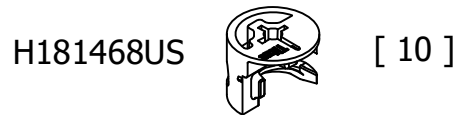
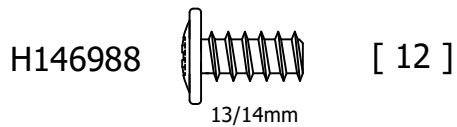
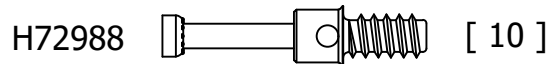
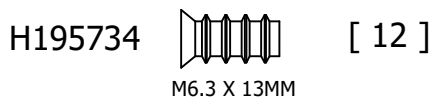
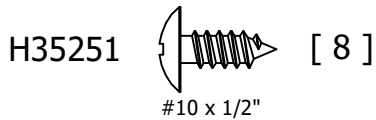
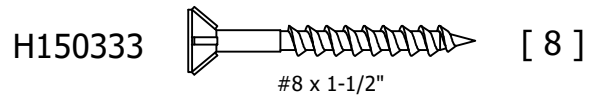
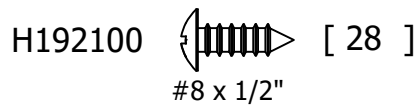
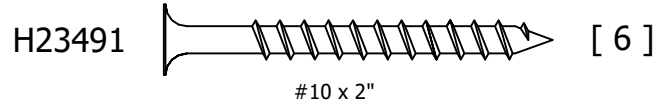
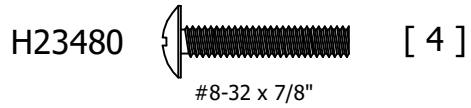

Hardware - Quincaillerie - Quincaillas

Not to Scale - No a escala - Pas à l'échelle.

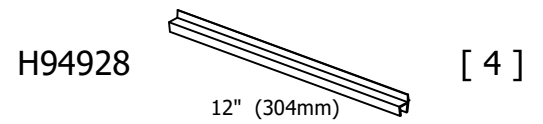
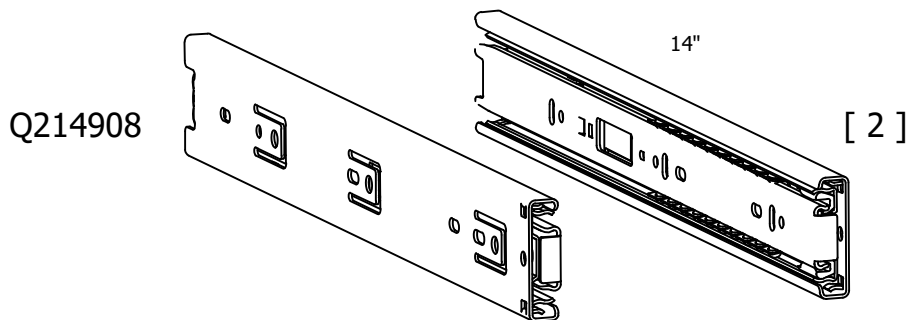
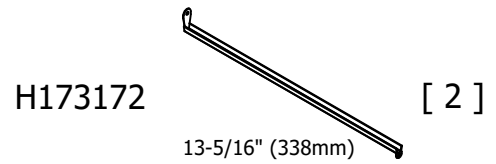
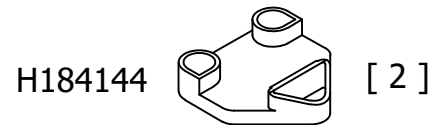
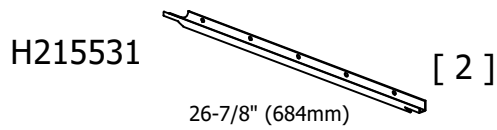
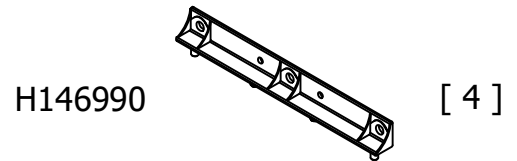
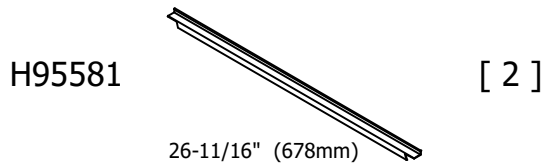
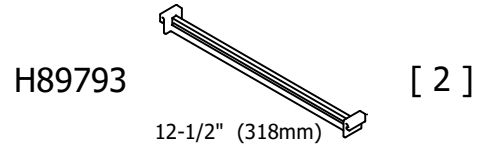
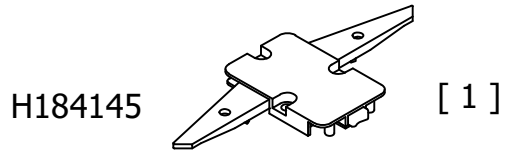

Hardware - Quincaillerie - Quincaillas

Not to Scale - No a escala - Pas à l'échelle.

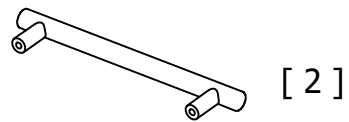
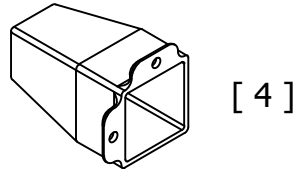

H146990

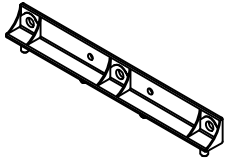

[4]

H146988

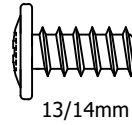

[12]

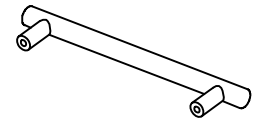

[2]

H23480

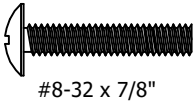

[4]

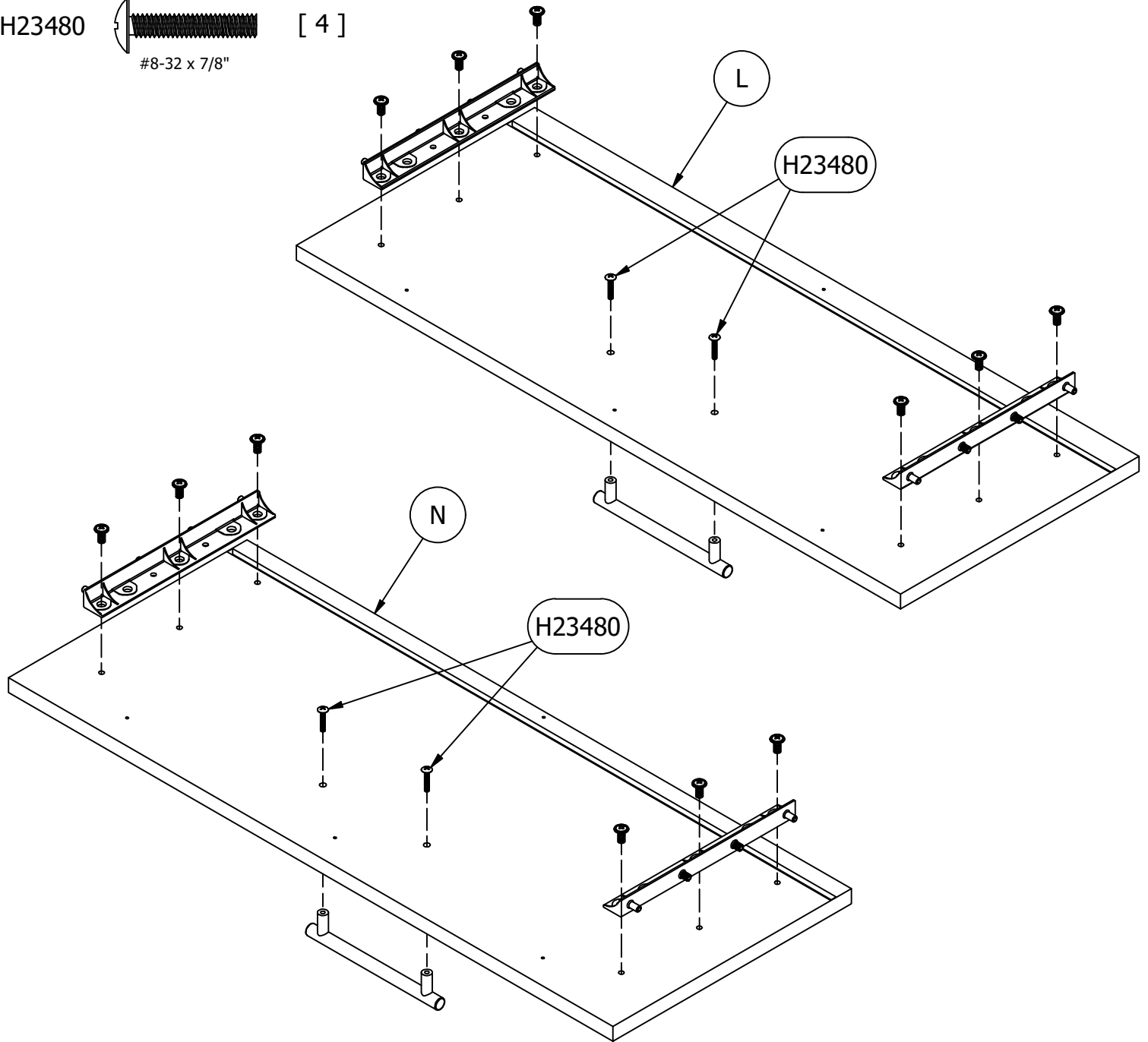

H218835  [8]
#8 x .5"

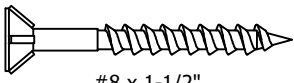
H150333  [8]
#8 x 1-1/2"

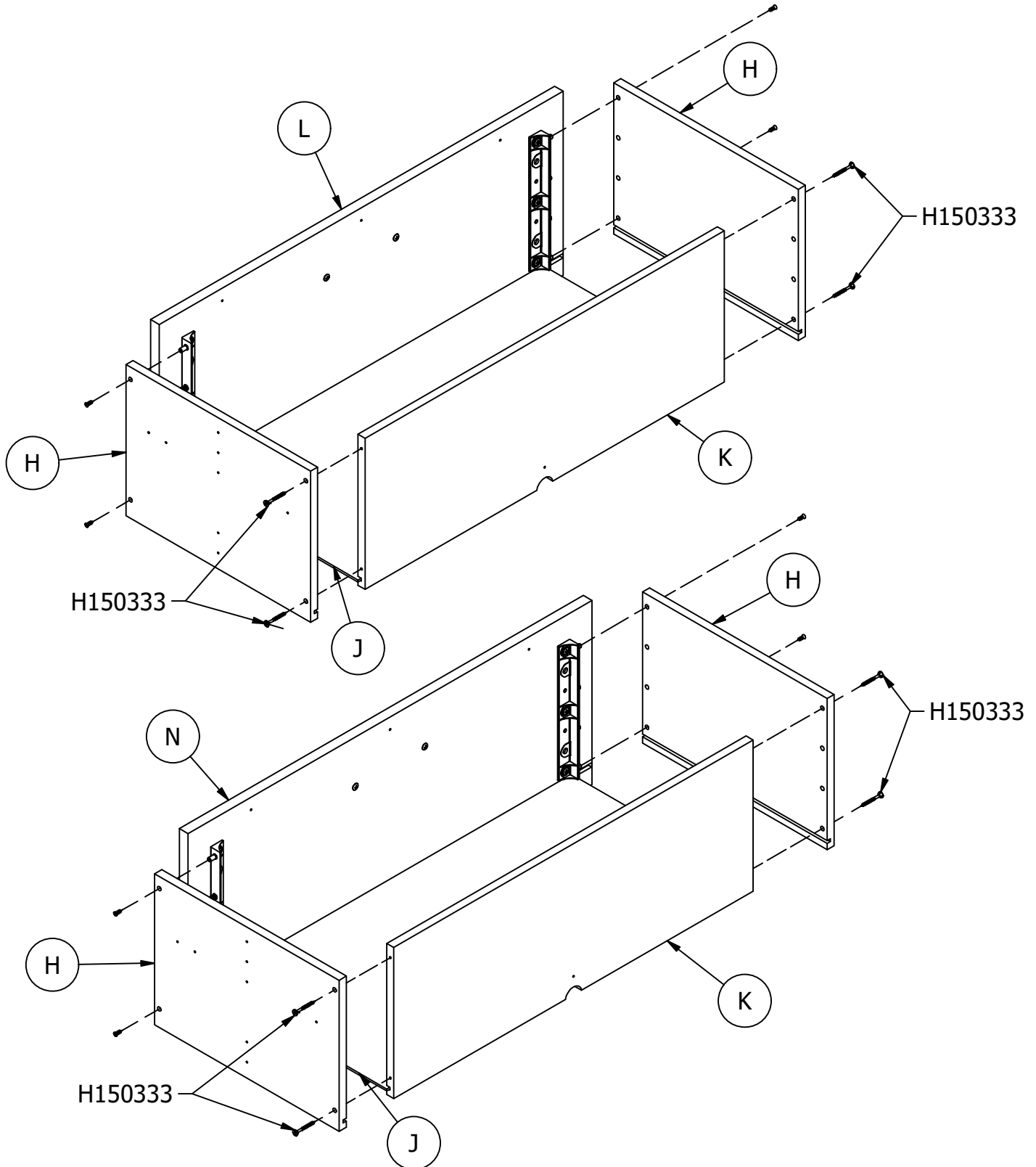

H173172

13-5/16" (338mm)

[2]

H192100

#8 x 1/2"

[4]

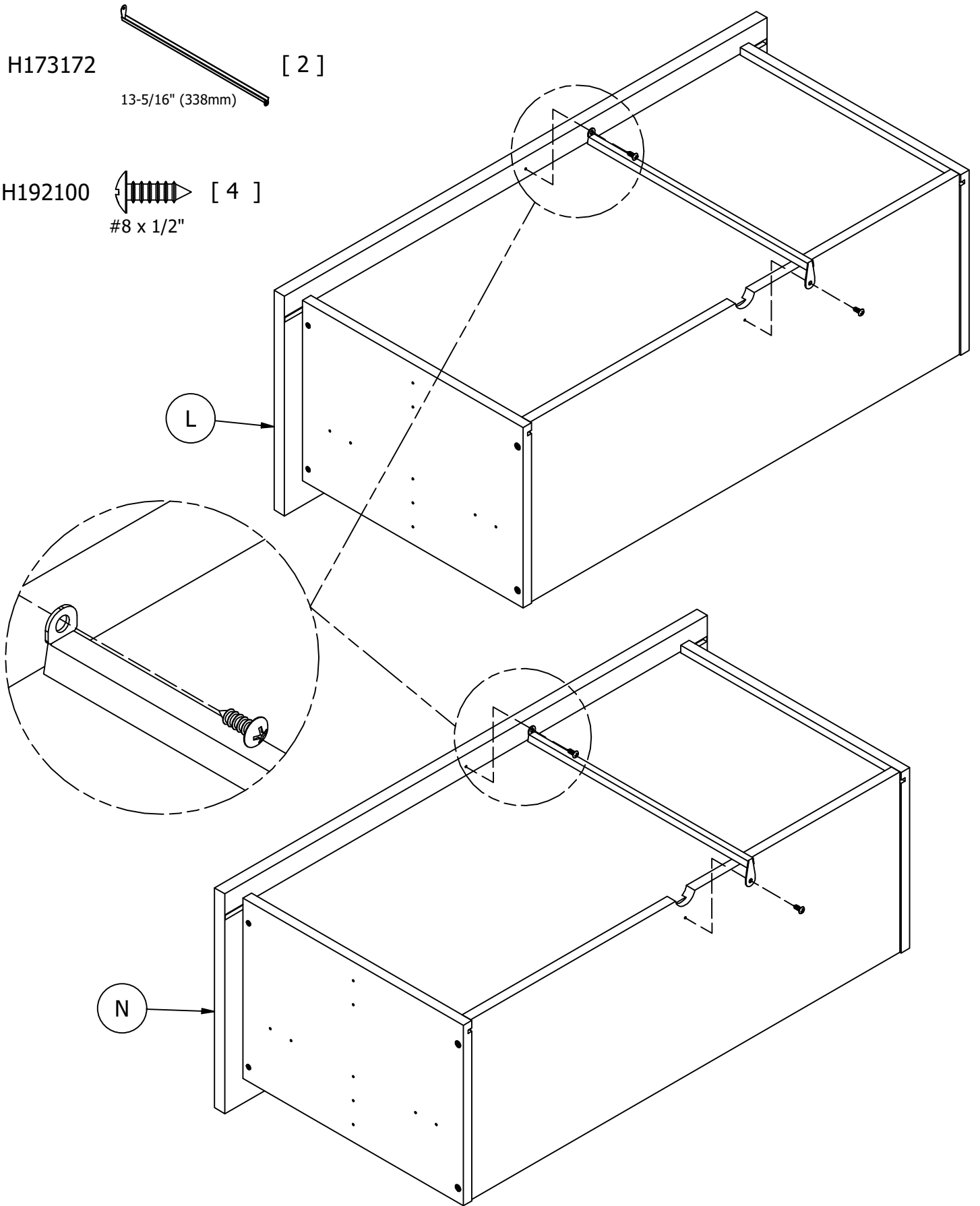

**Slides Must Be Separated Before Assembly.
After Separated, Set Aside Until Needed for Assembly.**

Las diapositivas deben separarse antes del montaje.
Después de la separación, déjelo a un lado hasta que sea necesario.

Les glissières doivent être séparées avant l'assemblage.
Après la séparation, mettez de côté jusqu'au moment de l'assemblage.

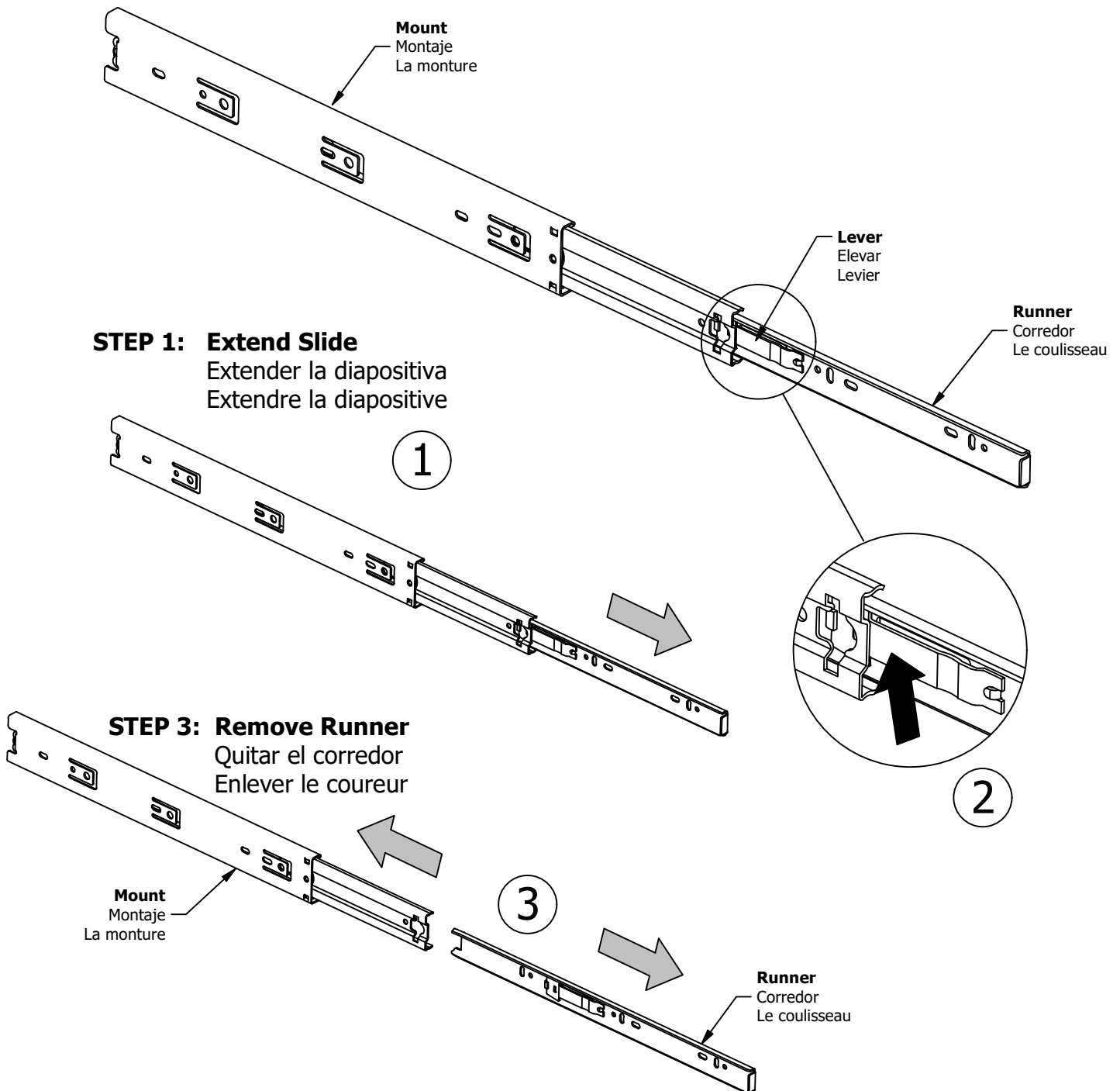

H192100 [18]
#8 x 1/2"

H215531 [2]
26-7/8" (684mm)

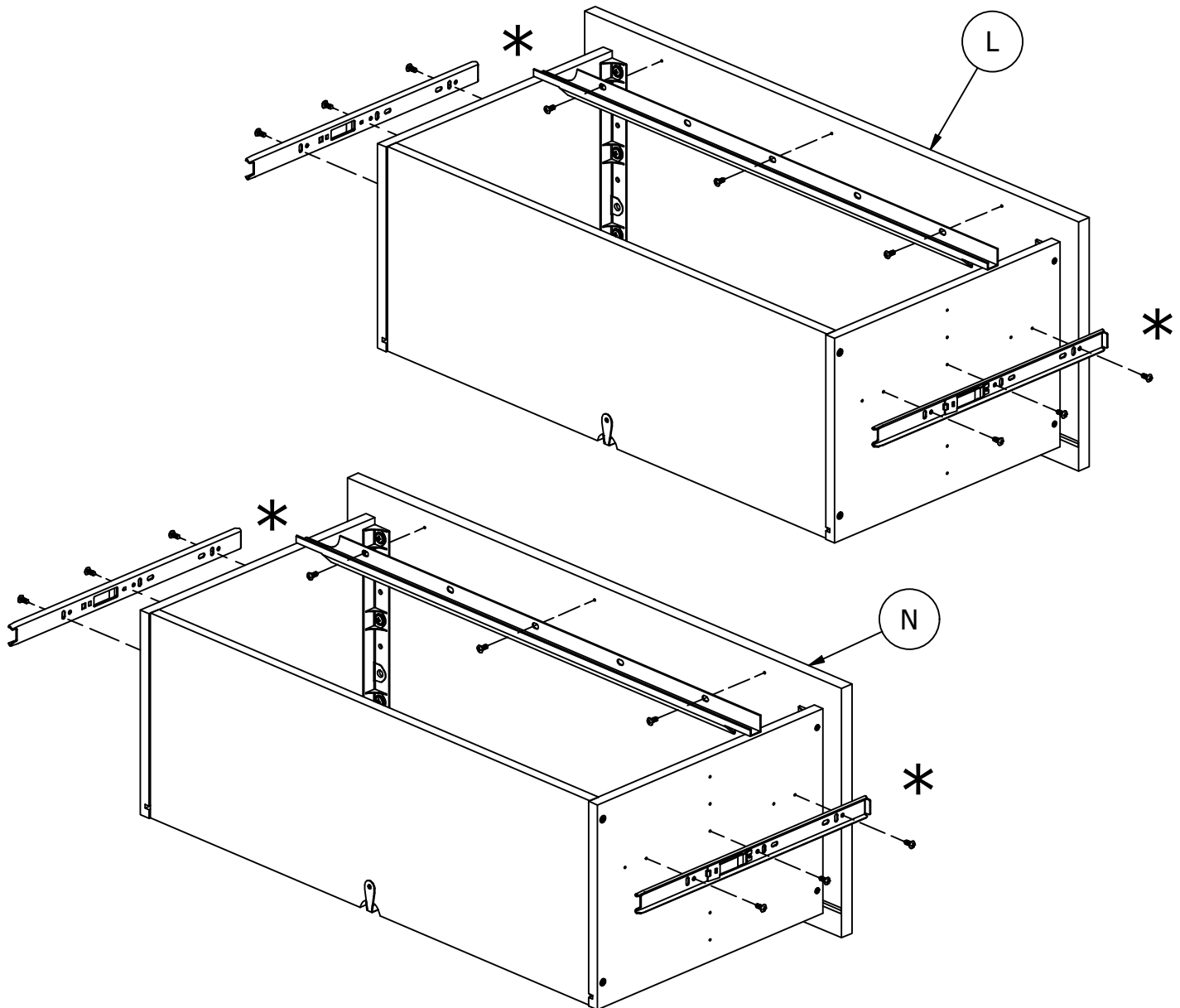
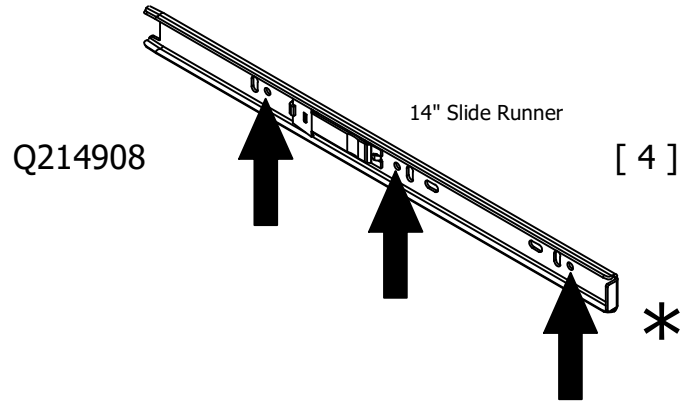

H95581

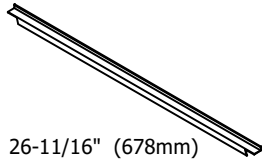

[2]

H89793

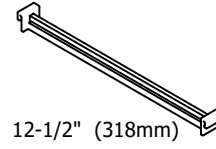

[2]

H94928

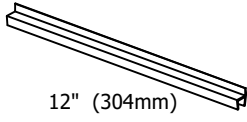

[4]

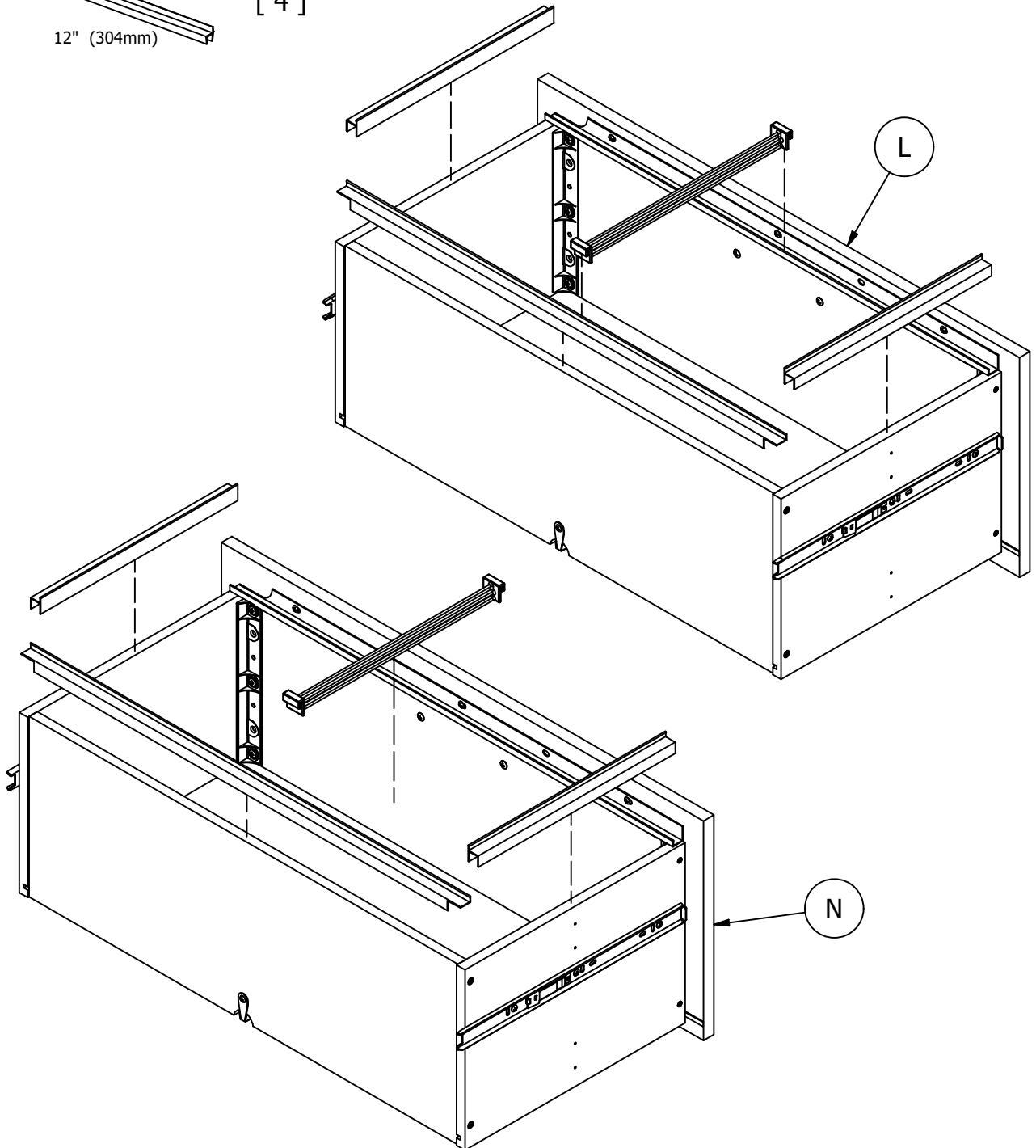

H184145

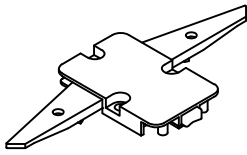

[1]

H72988

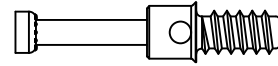

[2]

H192100

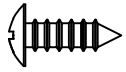

[2]

#8 x 1/2"

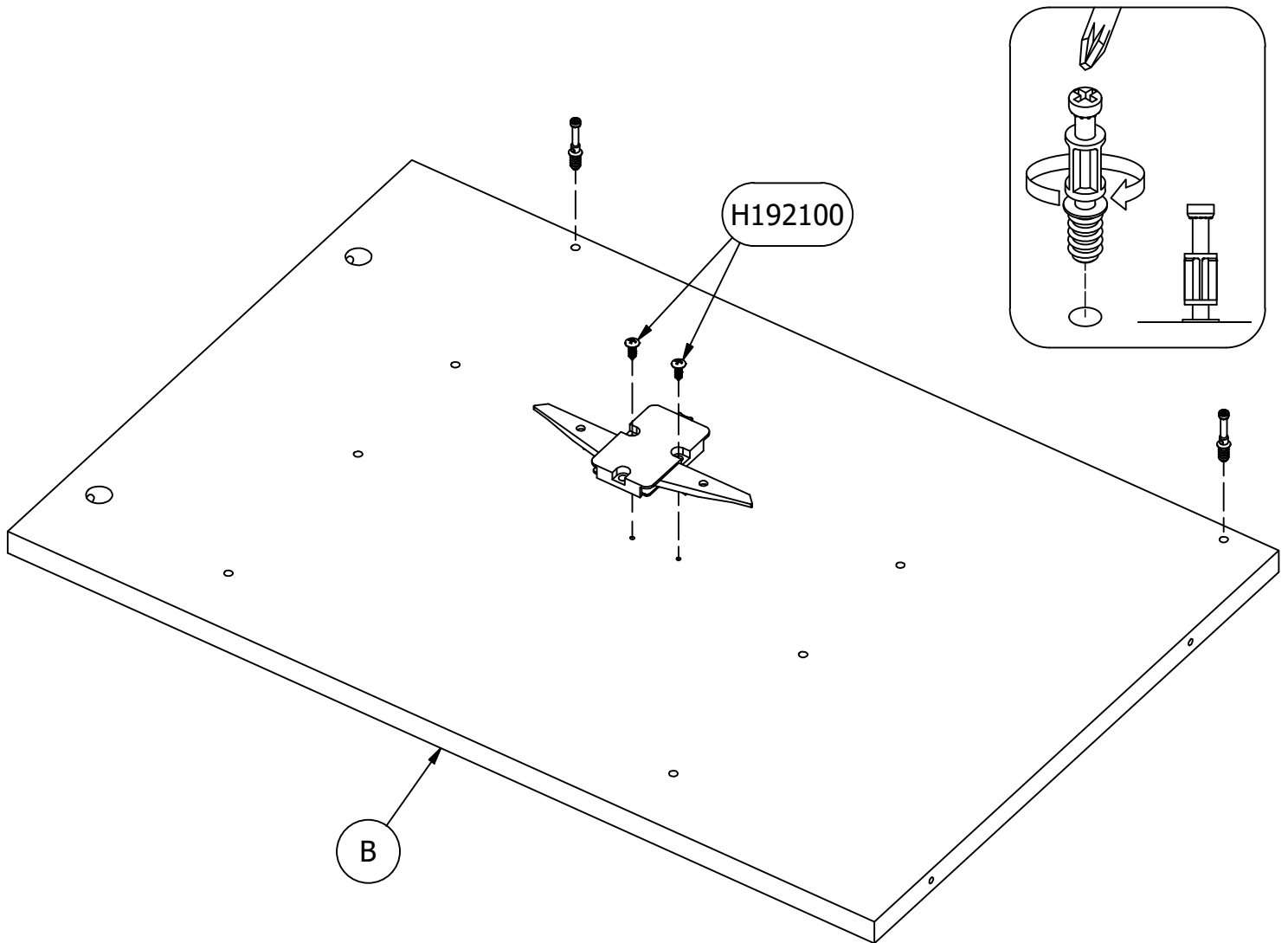

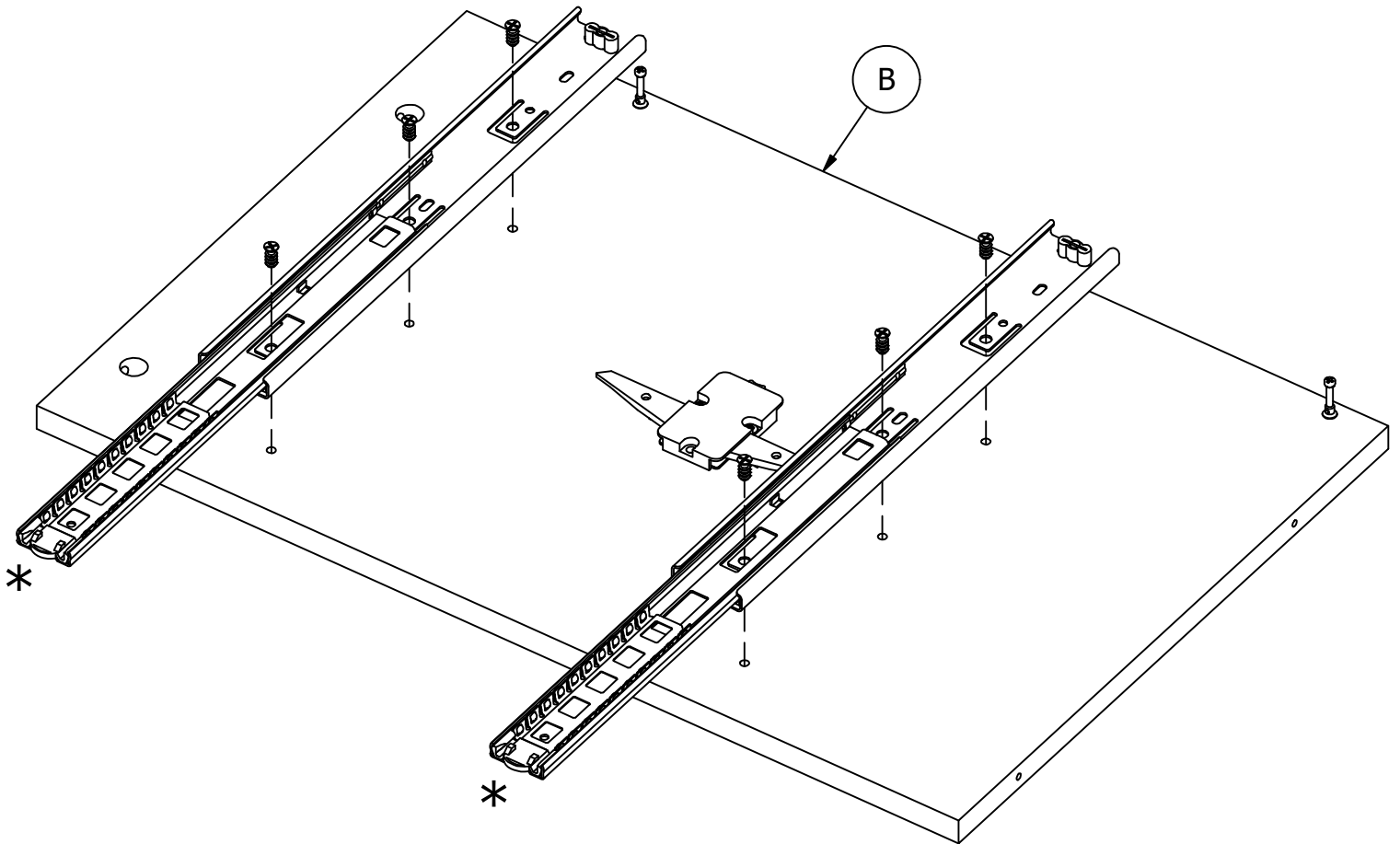
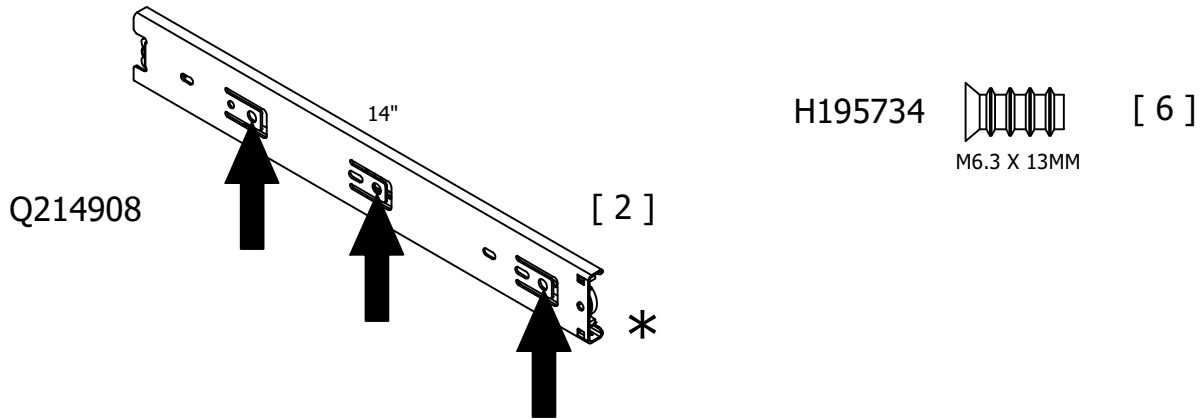

May need to move cage to insert screw.
Sera necesario mover el casillero para poder colocar el tornillo.
Vous devrez peut-être déplacer la cage pour insérer la vis.

H195734 [6]
M6.3 X 13MM

H72988 [2]

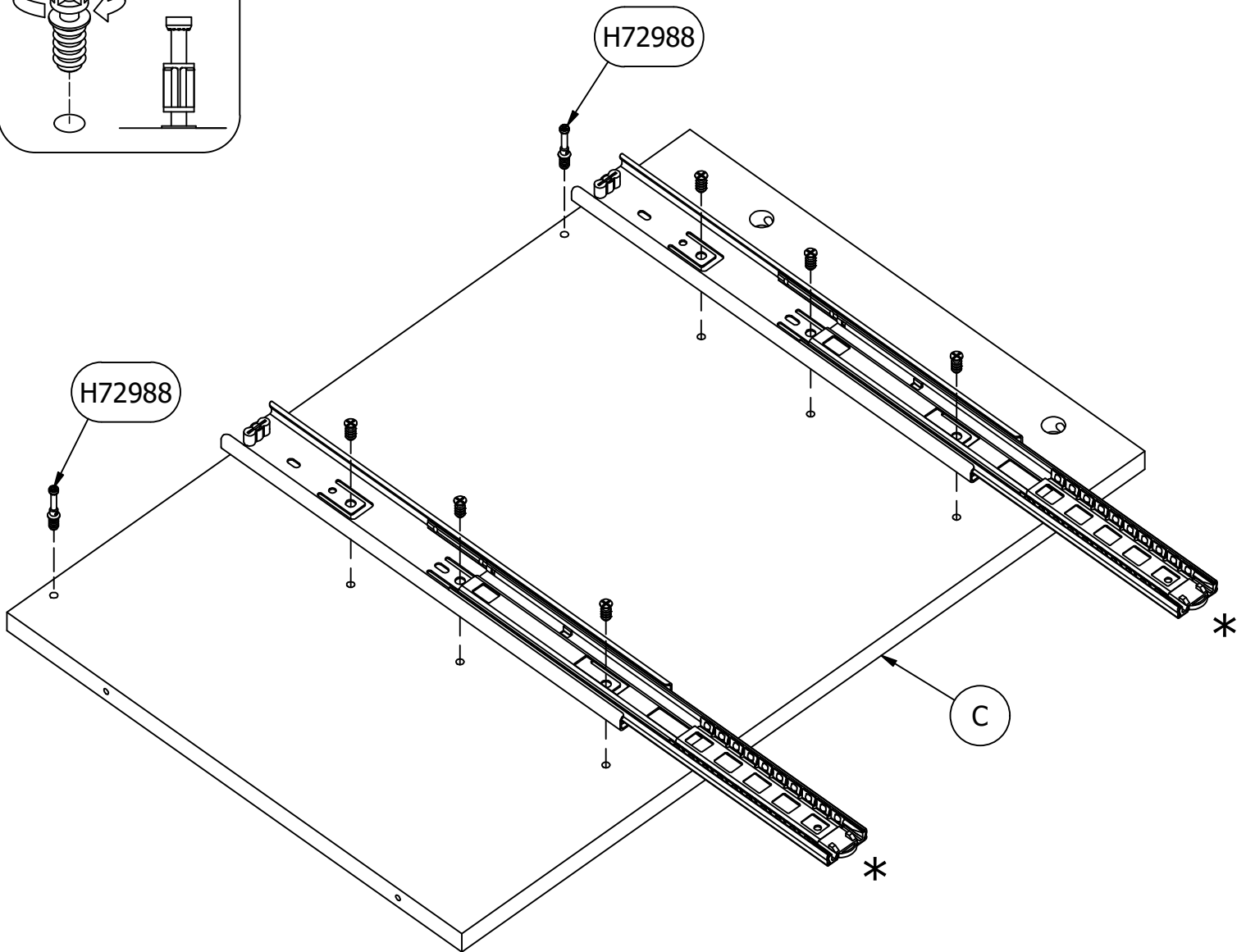
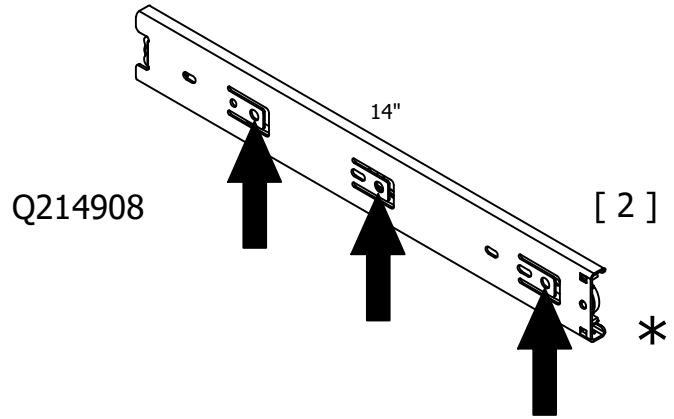
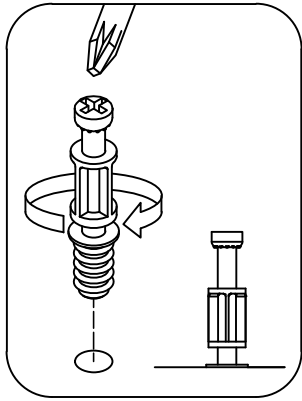

H181468US



[4]

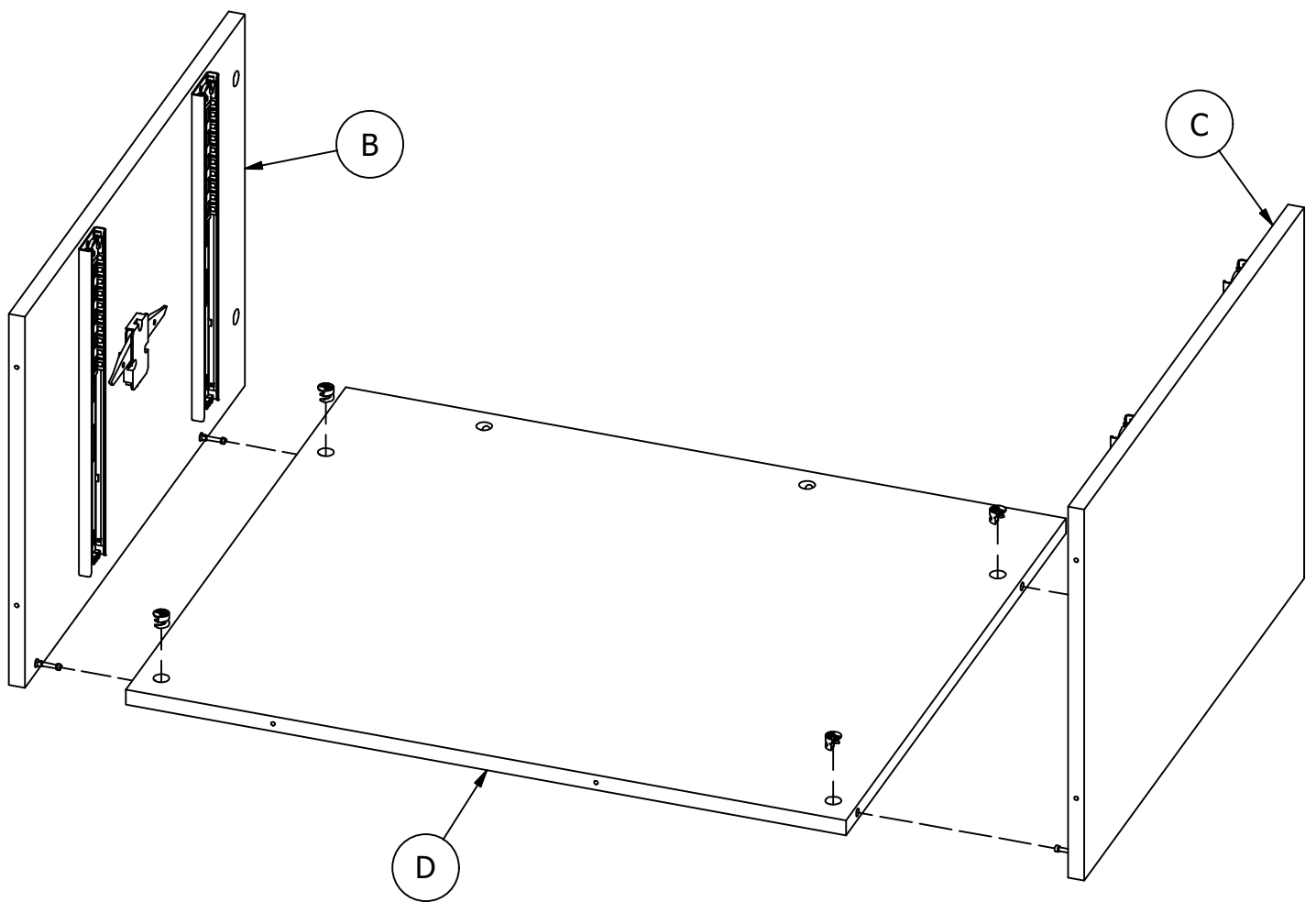
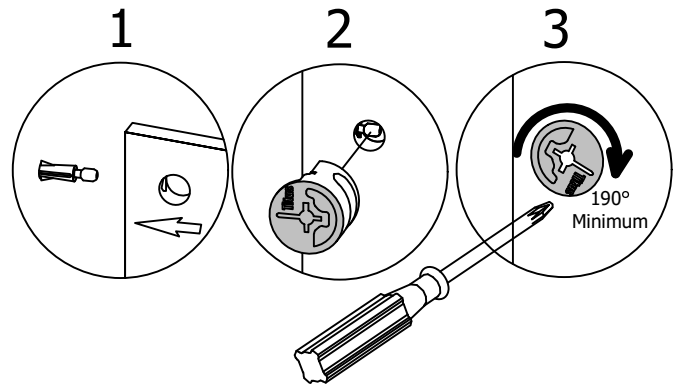

H72988 [6]

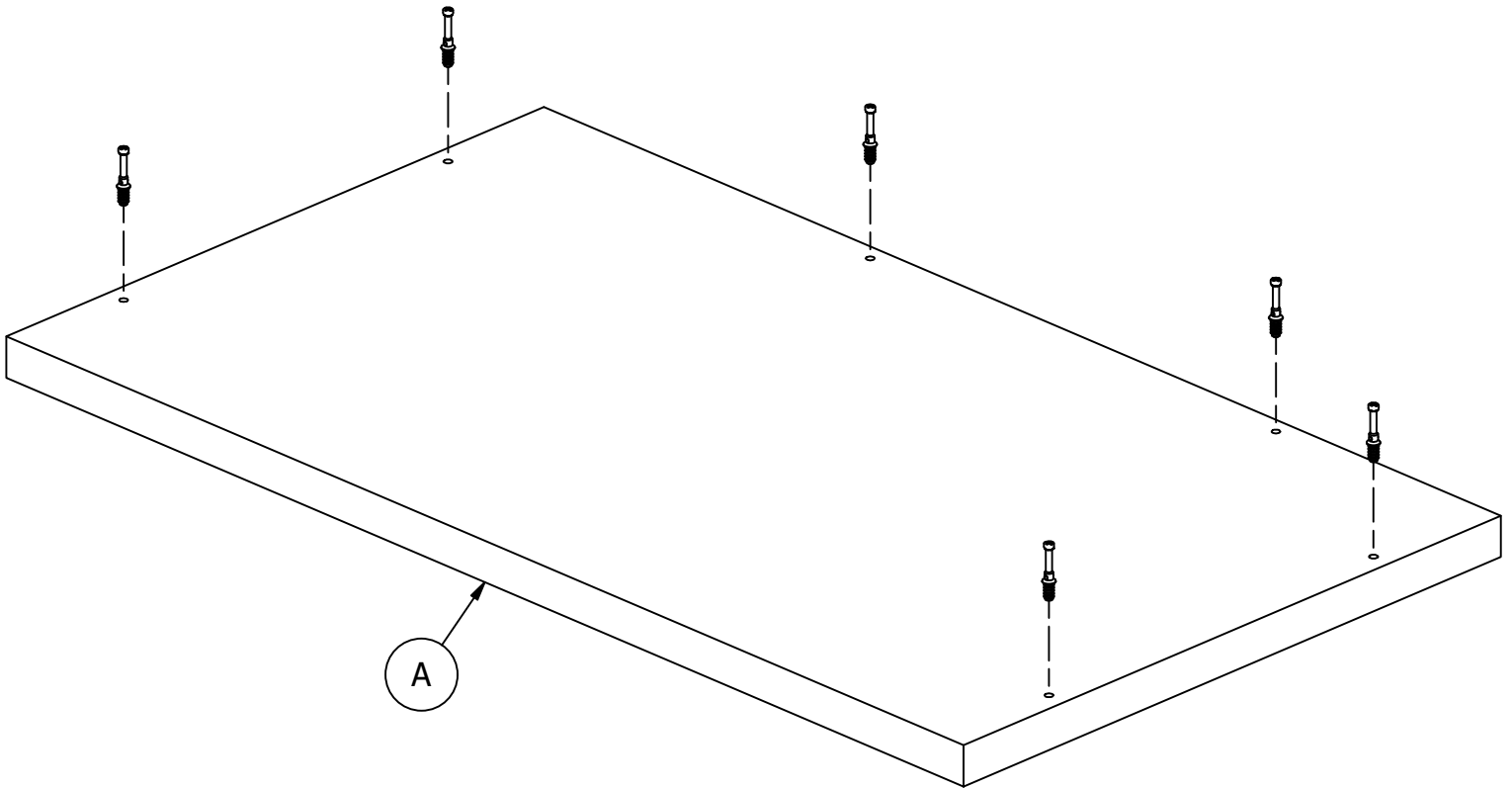
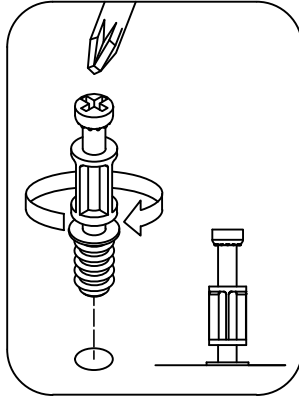
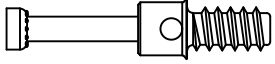

H181468US



[6]

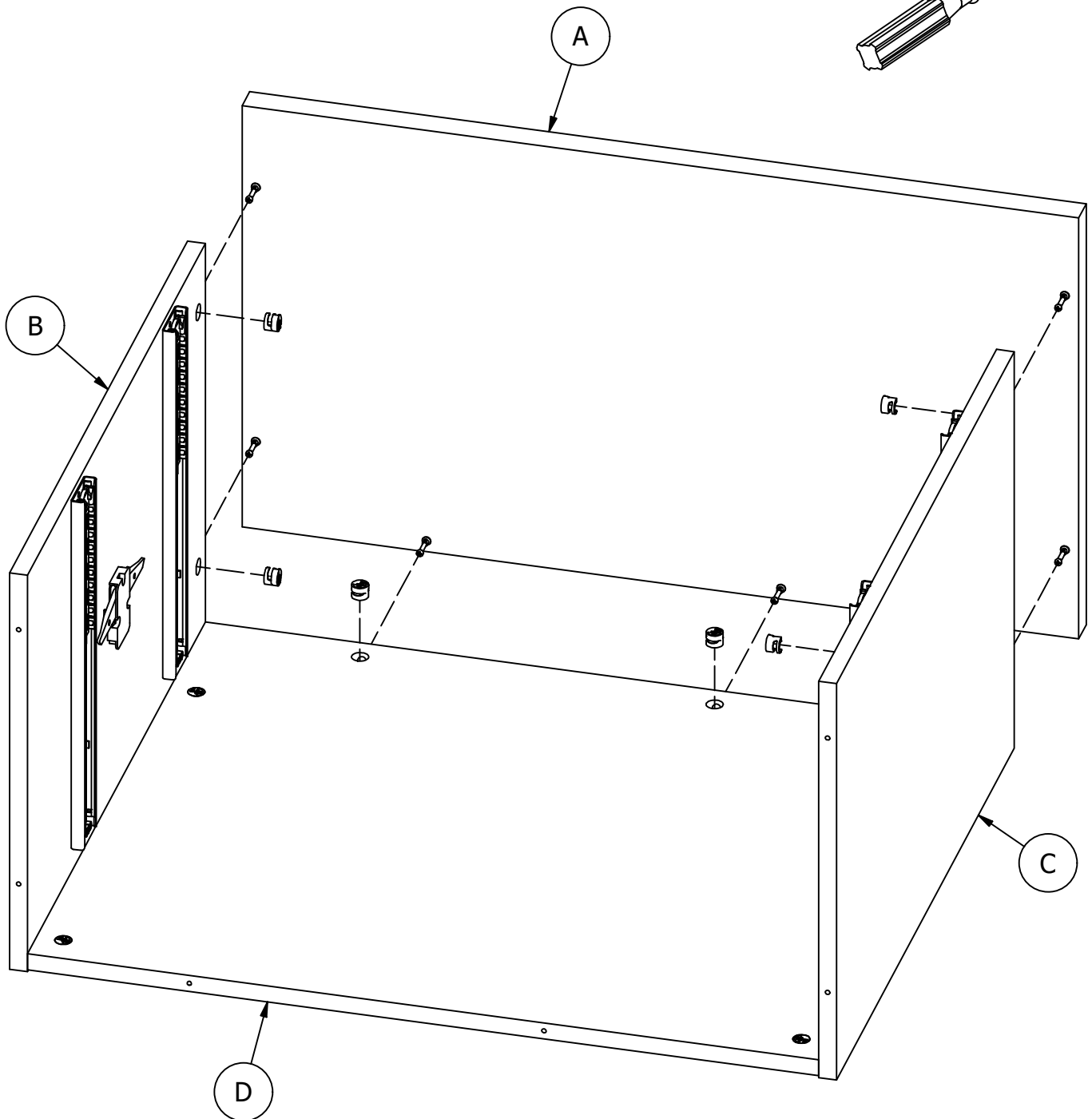
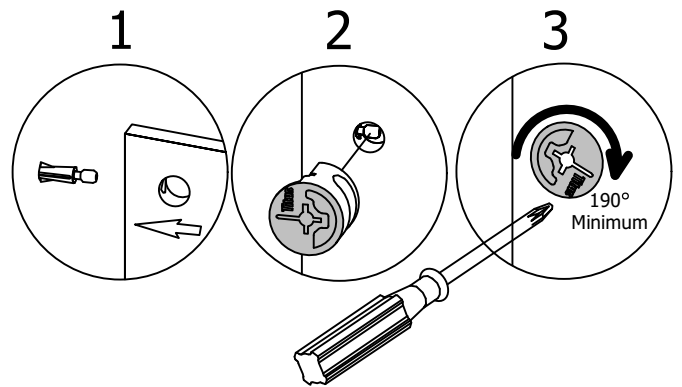

H35251 [8]
#10 x 1/2"

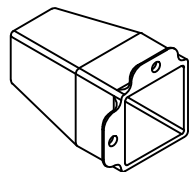

[4]

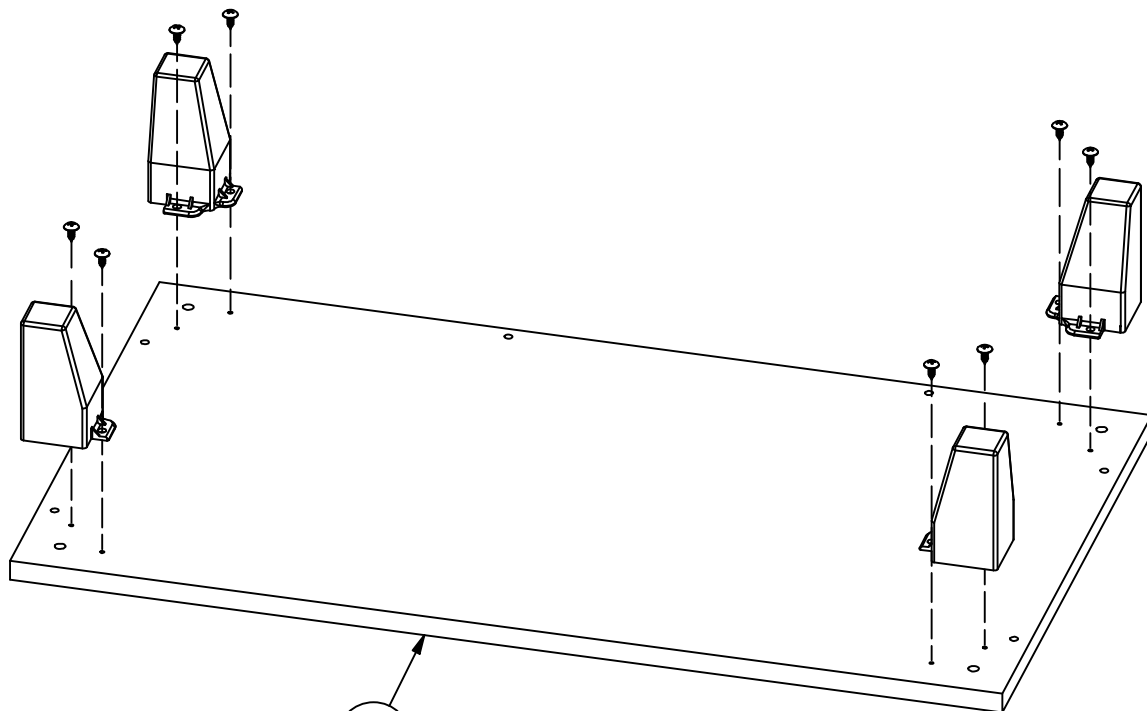

E

H143460 [4]
#12 x 4"

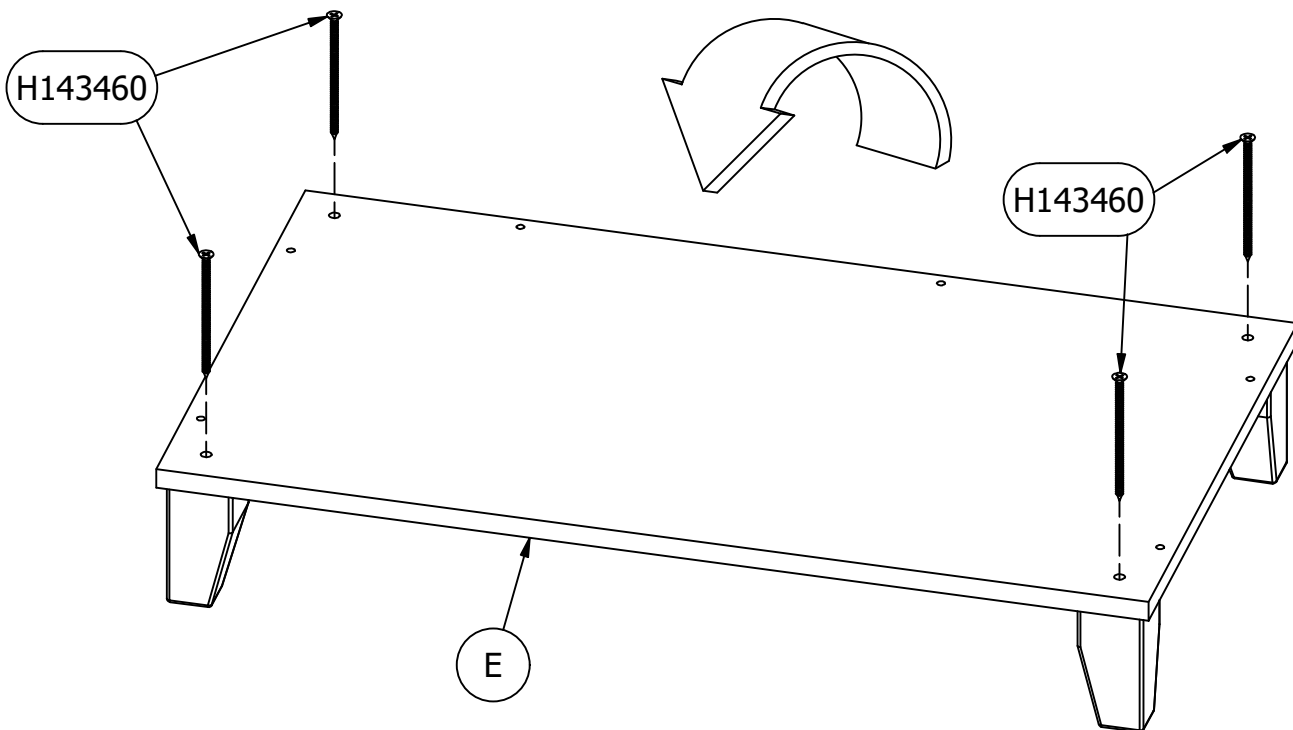

E

H23491 [6]
#10 x 2"

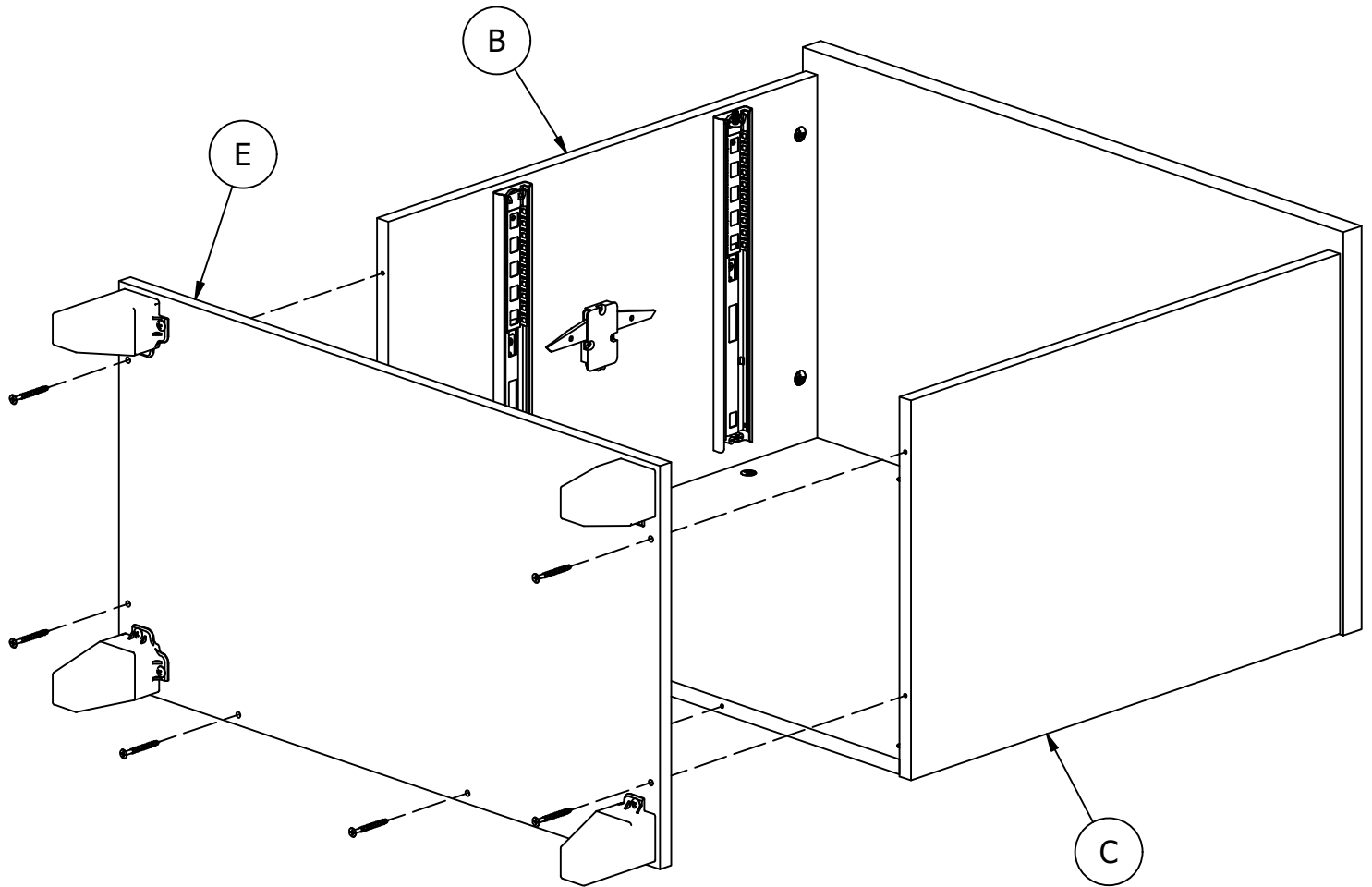

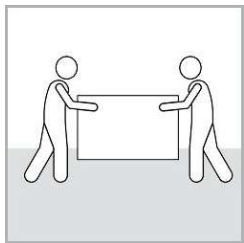

Team Lift
Esfuerzo de equipo
Effort d'équipe

1

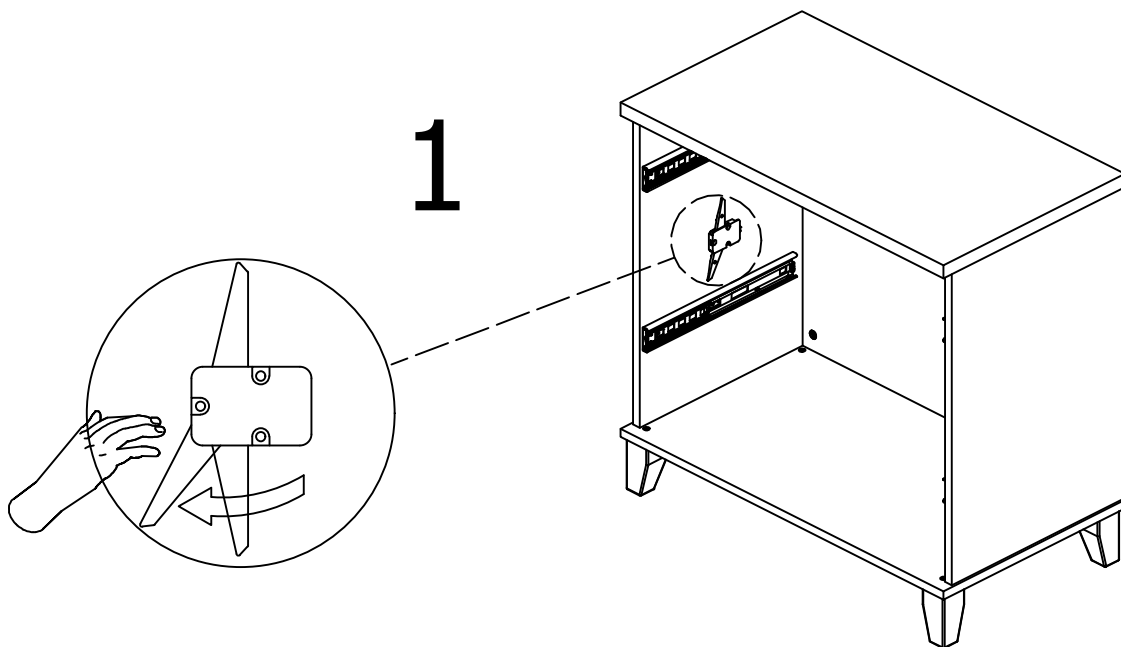

2

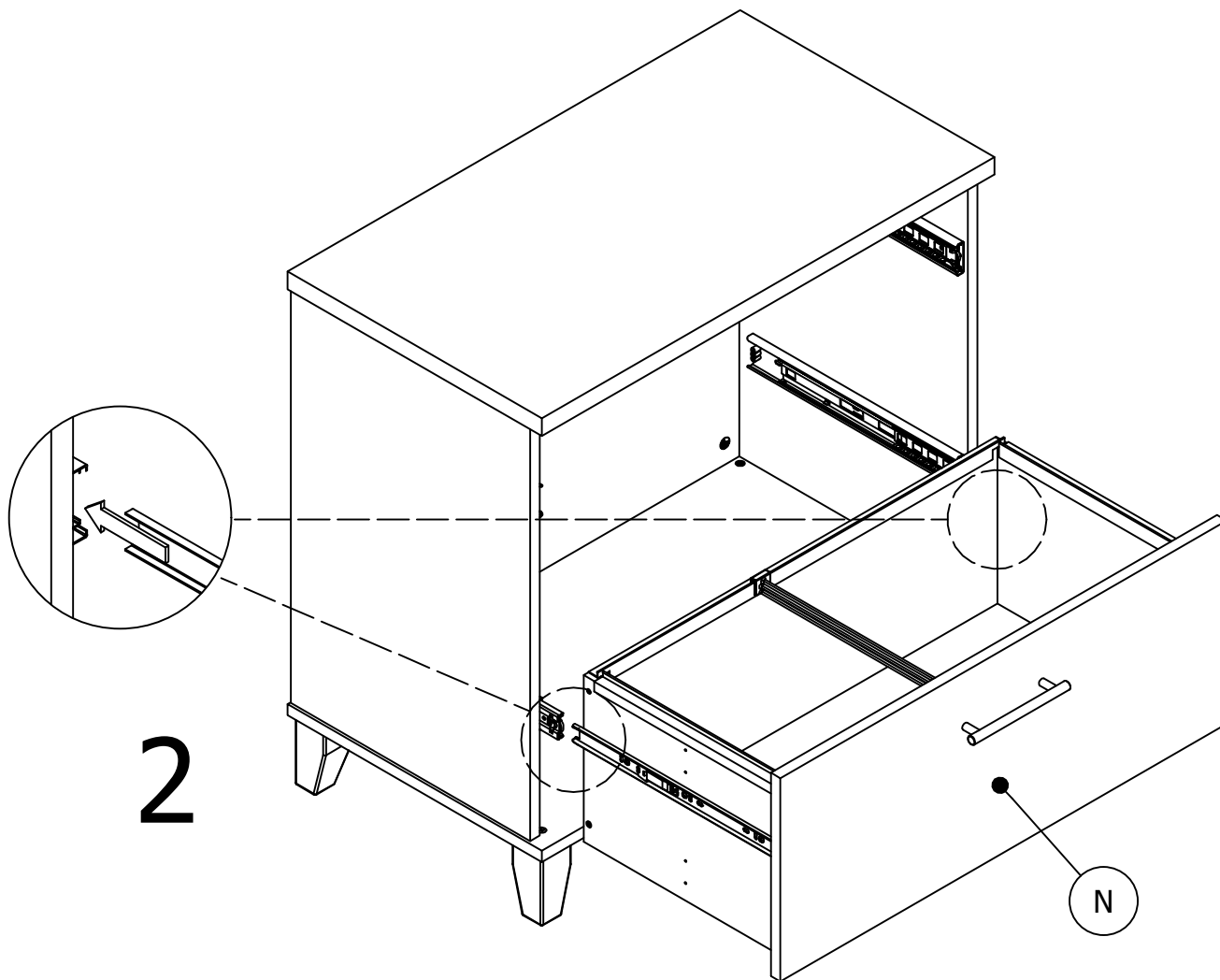

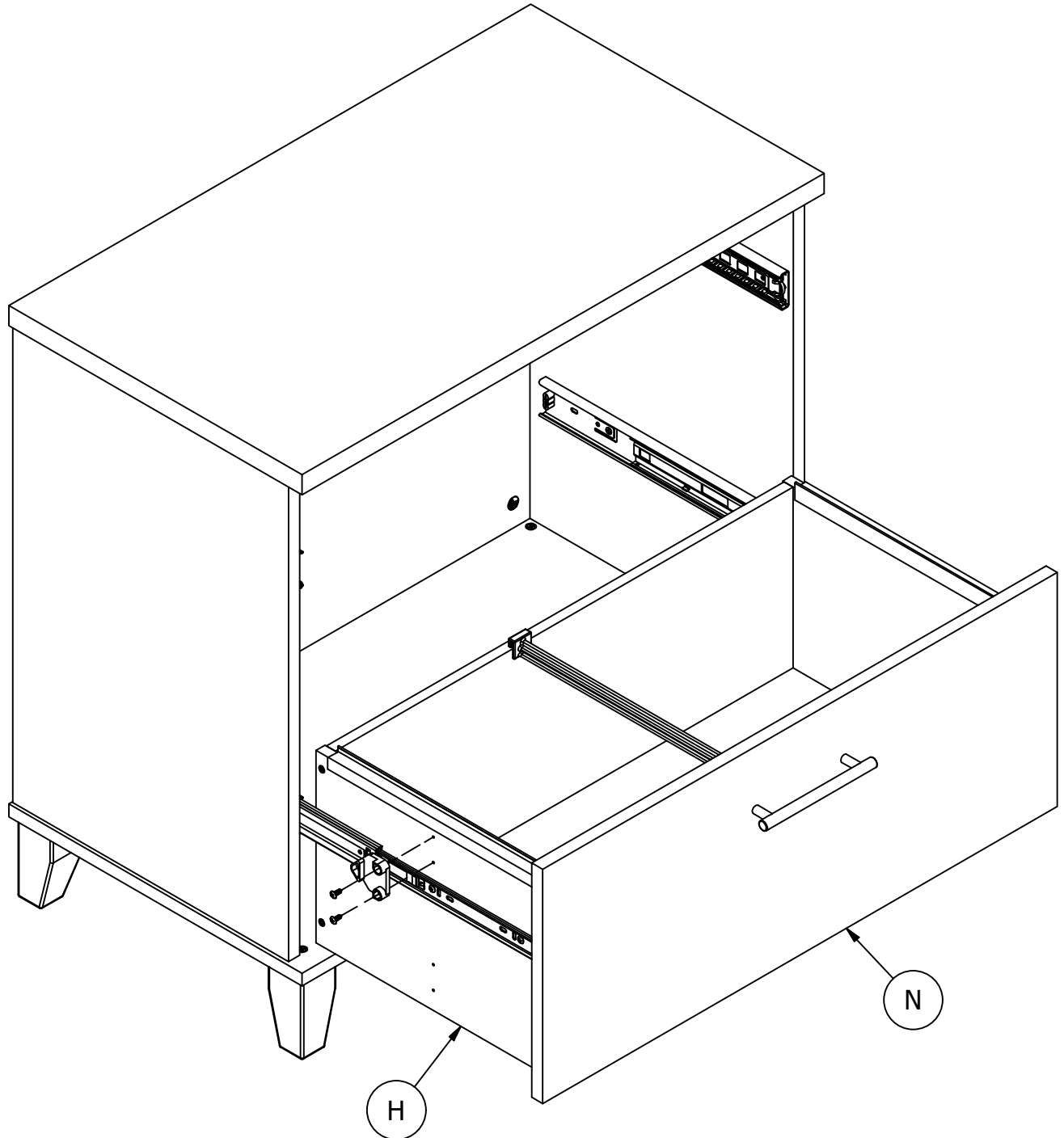
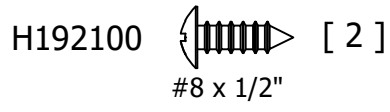
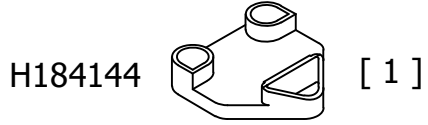

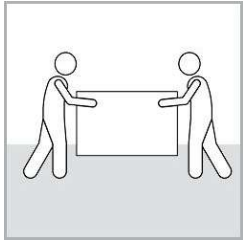

Team Lift
Esfuerzo de equipo
Effort d'équipe

1

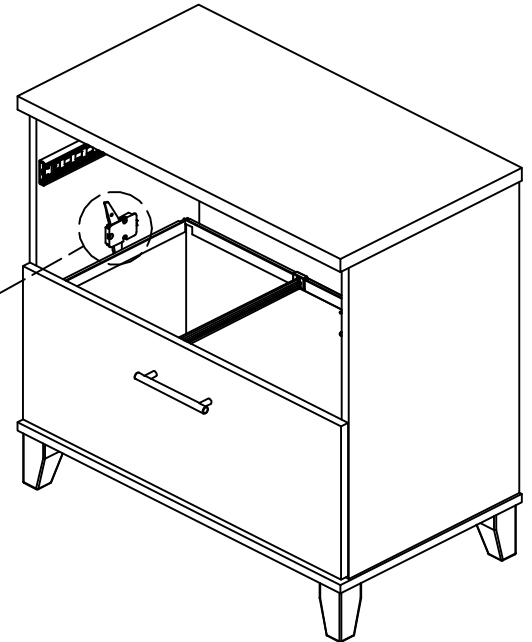
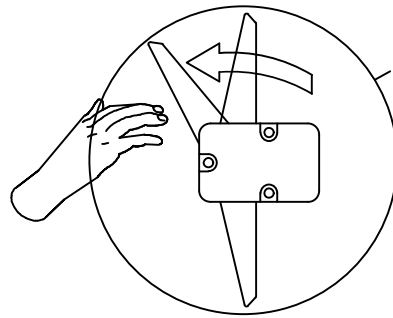

2

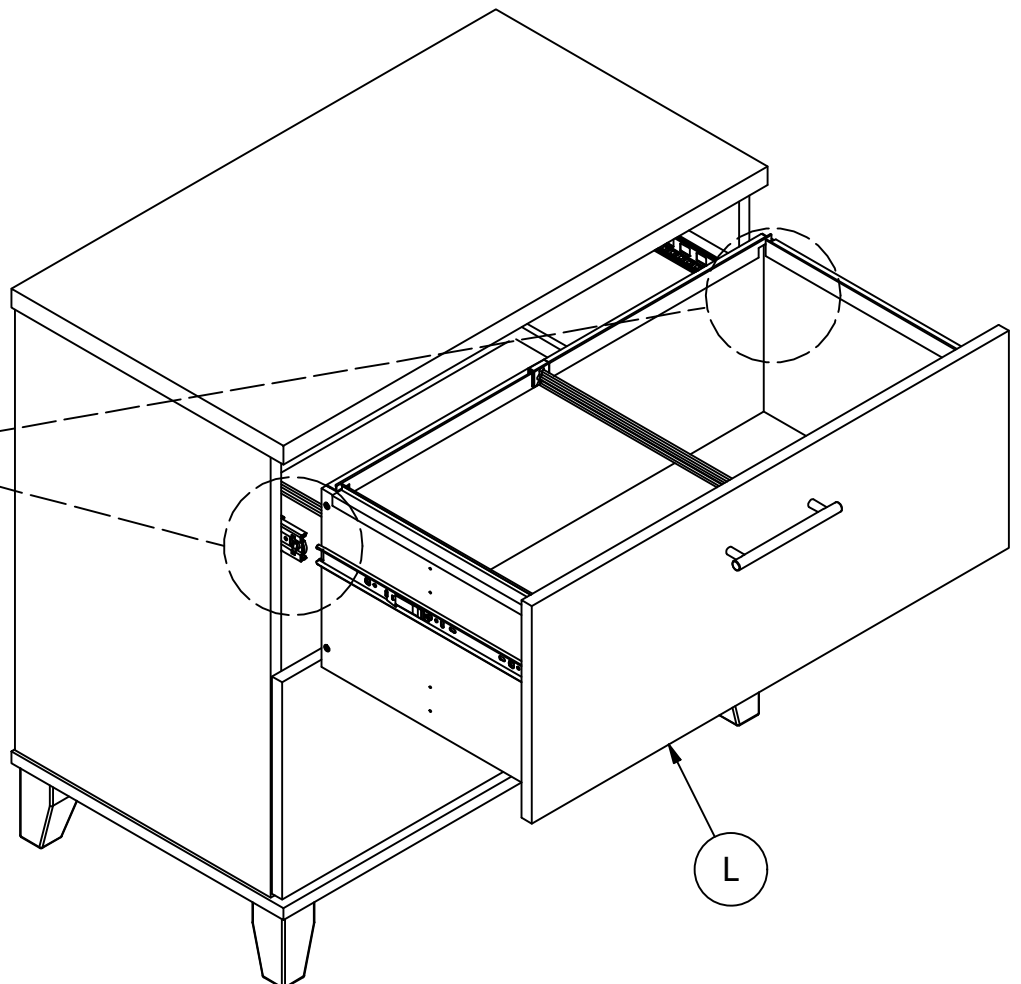
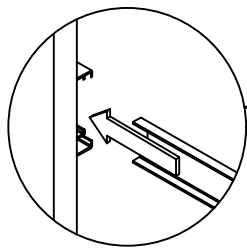

H184144

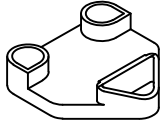

[1]

H192100

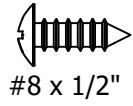

[2]

#8 x 1/2"

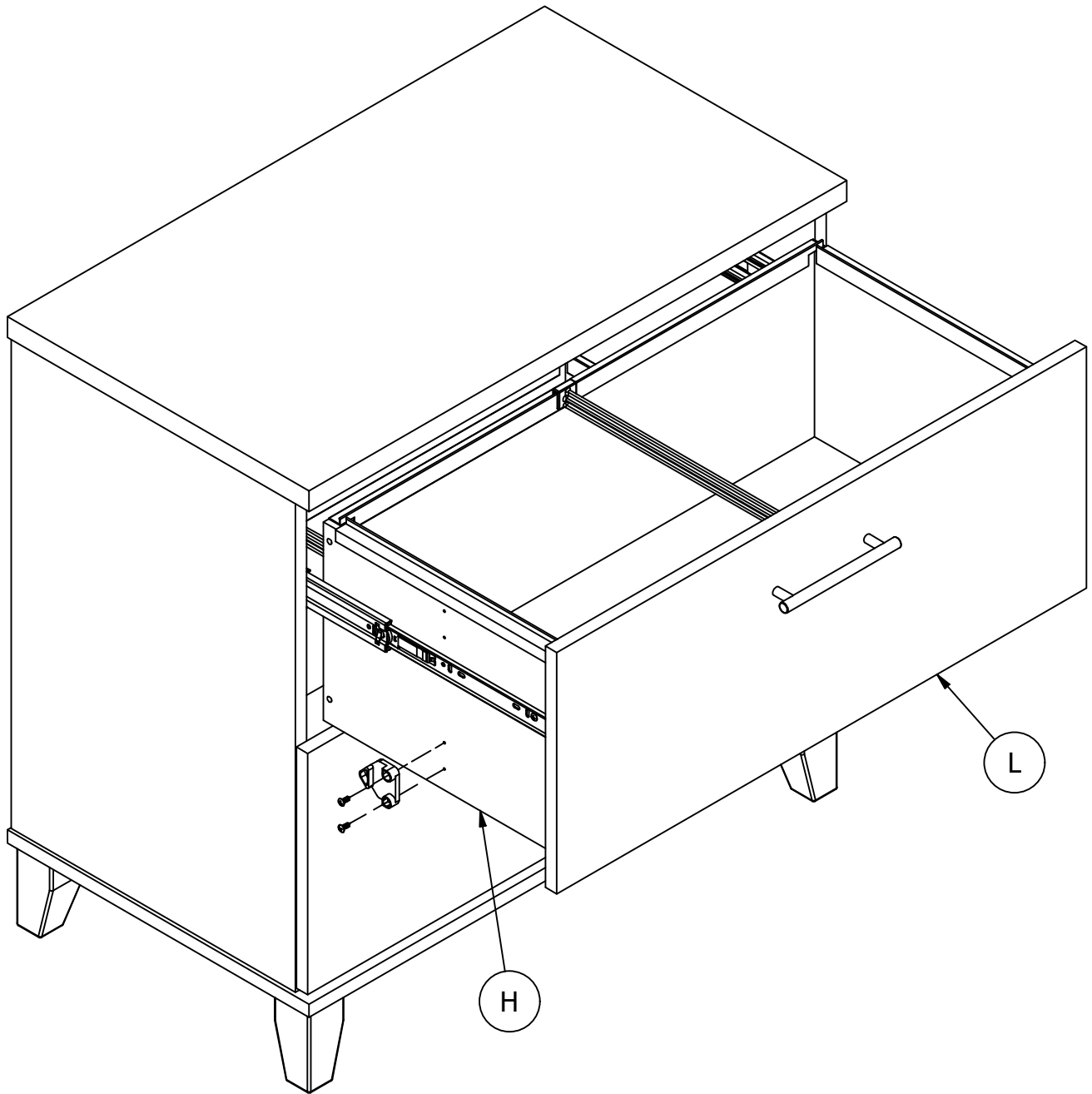

DRAWER FRONT VIEW
VISTA FRONTAL DEL CAJÓN
TIROIRS VUS DE FACE

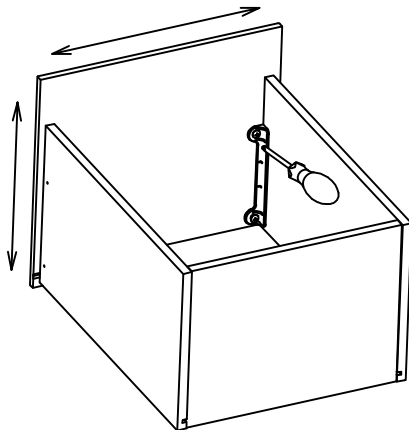
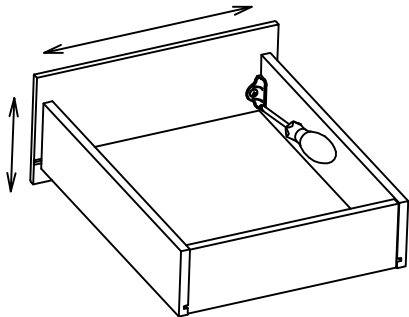
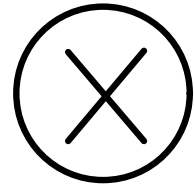
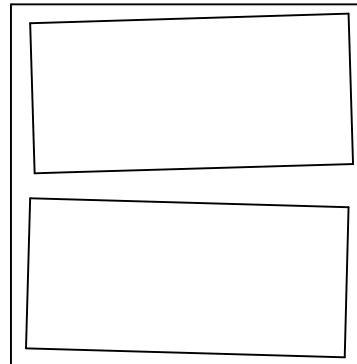
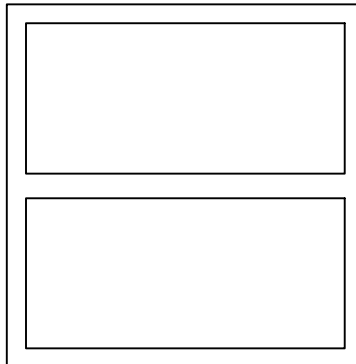
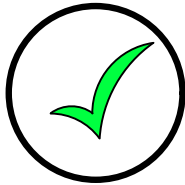

REQUIRED TOOL: PHILLIPS SCREWDRIVER

HERRAMIENTA REQUERIDA: DESTORNILLADOR PHILLIPS
OUTIL REQUIS: TOURNEVIS CRUCIFORME



1. LOOSEN SCREWS.
2. ADJUST DRAWER FRONTS.
3. TIGHTEN SCREWS.

1. Afloje los tornillos
2. Ajustar frentes de cajón
3. Apriete los tornillos

1. Desserrer les vis
2. Ajuster les façades des tiroirs
3. Serrer les vis

Gently clean surfaces with
a damp sponge eraser.

Maximum Weight: 200 Lbs.
Peso Máximo: 200 Libras
Poids Maximum: 90.7 kilogramme

Maximum Weight: 56 Lbs.
Peso Máximo: 56 Libras
Poids Maximum: 25.4 kilogramme

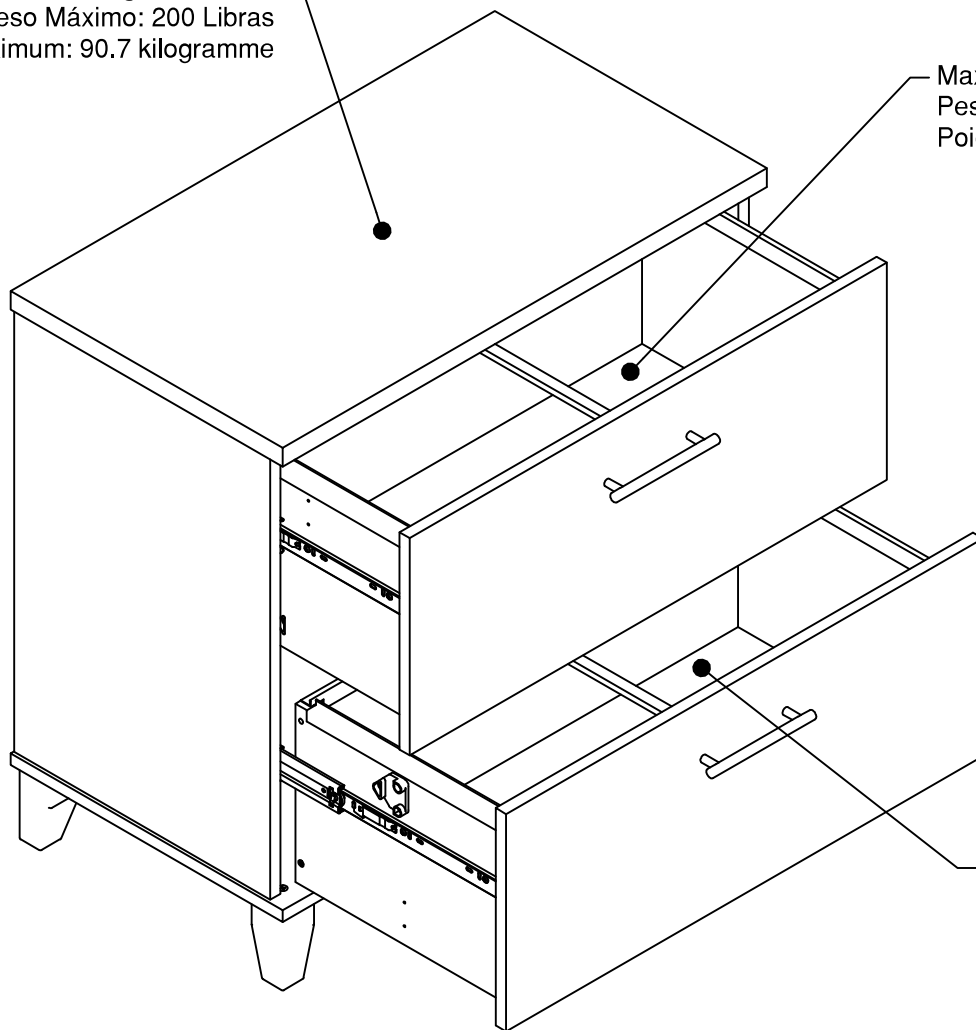

Maximum Weight: 57 Lbs.
Peso Máximo: 57 Libras
Poids Maximum: 25.8 kilogramme

Congratulations! You are all done. If
you have any questions or concerns,
please call.

WC81080

A	[1]	W200557
B	[1]	W196123
C	[1]	W196124
D	[1]	W193946
E	[1]	W196126
H	[4]	W195638
J	[2]	W182006
K	[2]	W195675
L	[1]	W195704
N	[1]	W195705

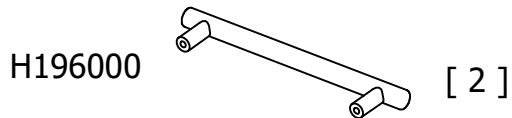
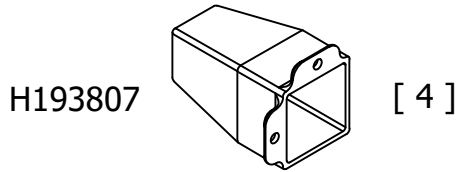

WC81180

A	[1]	W200534
B	[1]	W200535
C	[1]	W200536
D	[1]	W200537
E	[1]	W200538
H	[4]	W195638
J	[2]	W182006
K	[2]	W195675
L	[1]	W200539
N	[1]	W200540

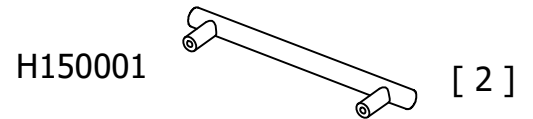
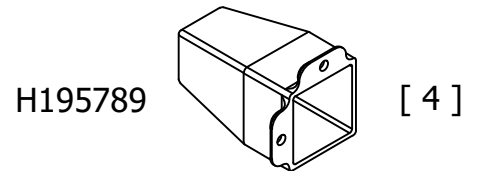

WC81380

A	[1]	W200440
B	[1]	W200441
C	[1]	W200442
D	[1]	W200443
E	[1]	W200444
H	[4]	W195638
J	[2]	W182006
K	[2]	W195675
L	[1]	W200445
N	[1]	W200446

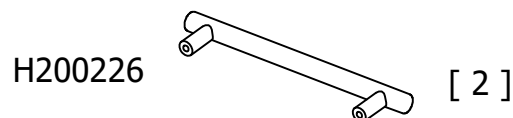
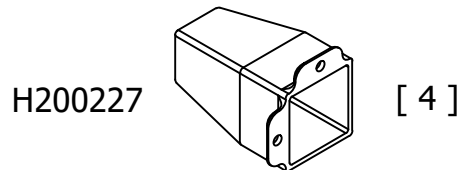

WC81280

A	[1]	W195915
B	[1]	W195916
C	[1]	W195917
D	[1]	W195918
E	[1]	W195919
H	[4]	W195638
J	[2]	W182006
K	[2]	W195675
L	[1]	W195920
N	[1]	W195921

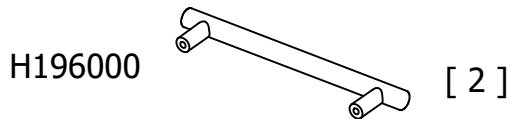
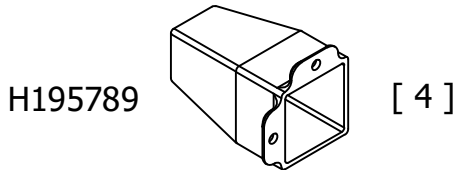

WC81480

A	[1]	W187339
B	[1]	W195698
C	[1]	W195699
D	[1]	W187342
E	[1]	W187343
H	[4]	W195638
J	[2]	W182006
K	[2]	W195675
L	[1]	W195700
N	[1]	W195701

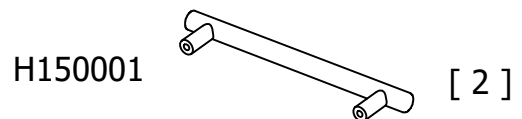
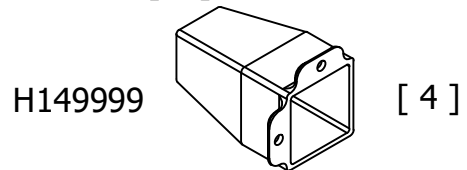

WC81580

A	[1]	W193943
B	[1]	W195702
C	[1]	W195703
D	[1]	W193946
E	[1]	W193947
H	[4]	W195638
J	[2]	W182006
K	[2]	W195675
L	[1]	W195704
N	[1]	W195705

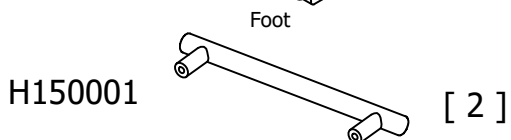
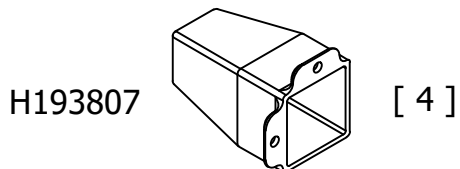

WC81680

A	[1]	W186625
B	[1]	W195706
C	[1]	W195707
D	[1]	W186628
E	[1]	W186629
H	[4]	W195638
J	[2]	W182006
K	[2]	W195675
L	[1]	W195708
N	[1]	W195709

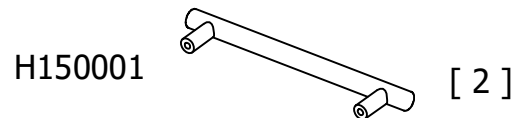
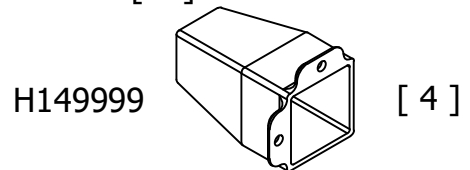

Parts - Pièces - Piezas

WC81780

A	[1]	W187346
B	[1]	W195711
C	[1]	W195710
D	[1]	W187349
E	[1]	W187350
H	[4]	W195638
J	[2]	W182006
K	[2]	W195675
L	[1]	W195712
N	[1]	W195713

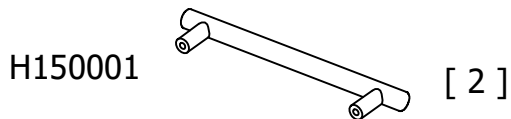
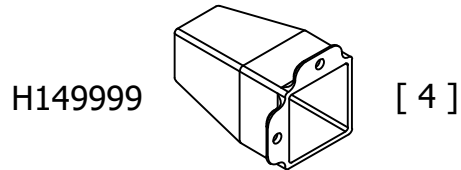

WC81880

A	[1]	W187353
B	[1]	W195714
C	[1]	W195715
D	[1]	W187356
E	[1]	W187357
H	[4]	W195638
J	[2]	W182006
K	[2]	W195675
L	[1]	W195716
N	[1]	W195717

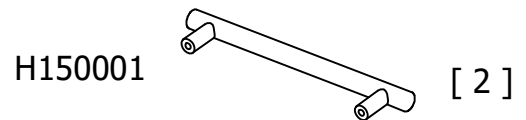
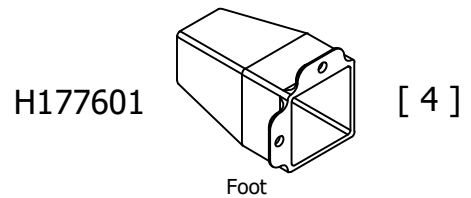

WC81980

A	[1]	W196122
B	[1]	W196123
C	[1]	W196124
D	[1]	W196125
E	[1]	W196126
H	[4]	W195638
J	[2]	W182006
K	[2]	W195675
L	[1]	W196127
N	[1]	W196128

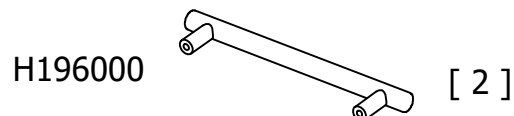
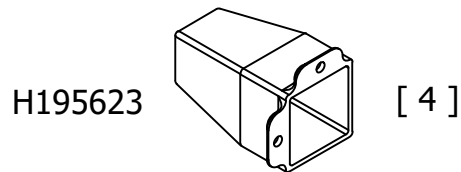

Maintenance Tip

It may be necessary to periodically open each drawer to its full extension. This will reset the drawer slides and allow for continued smooth operation.

Información de Mantenimiento

Puede ser necesario el abrir cada gaveta a su máxima extensión periódicamente. Este procedimiento ayuda a recomponer las correderas de las gavetas, asegurando una operación libre.

Conseil d'entretien

Il faut de temps en temps ouvrir chaque tiroir jusqu'au bout. Cela remboite les coulisses des tiroirs pour qu'elles continuent de fonctionner sans accroc.

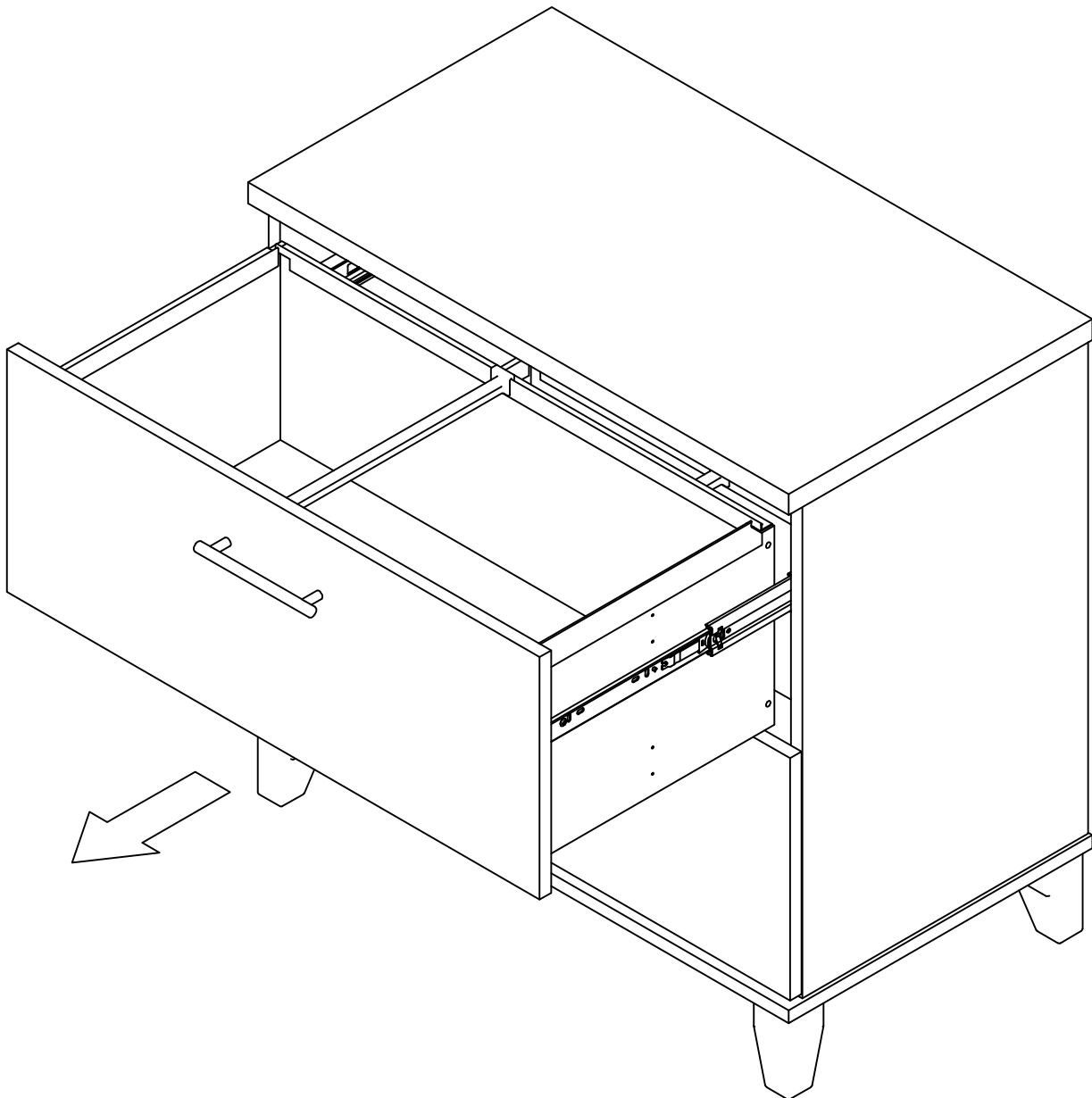

Maintenance - Entretien - Mantenimiento

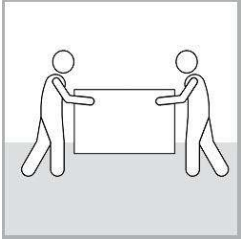

Team Lift
Esfuerzo de equipo
Effort d'équipe

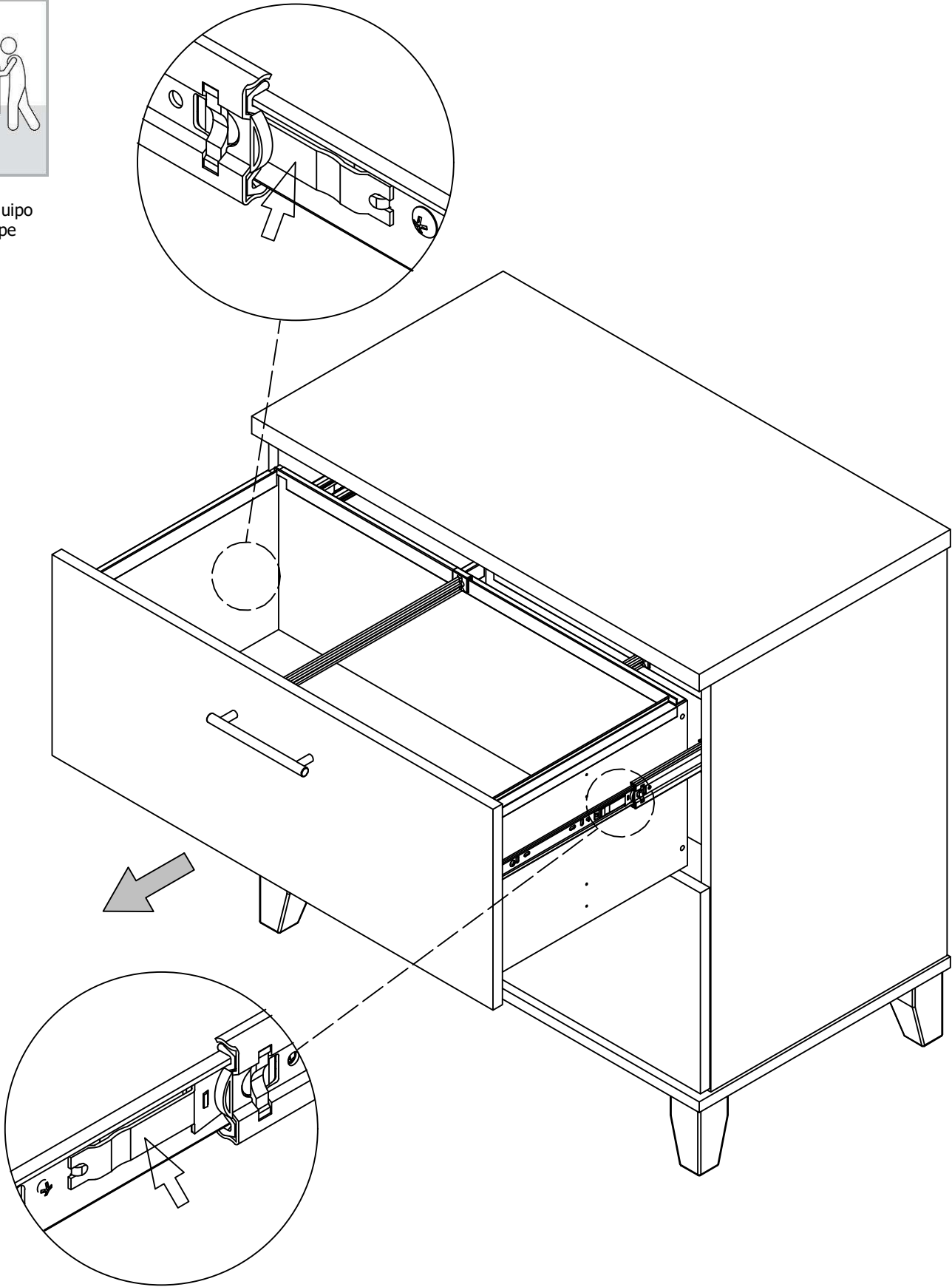

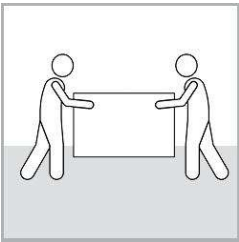

Team Lift
Esfuerzo de equipo
Effort d'équipe

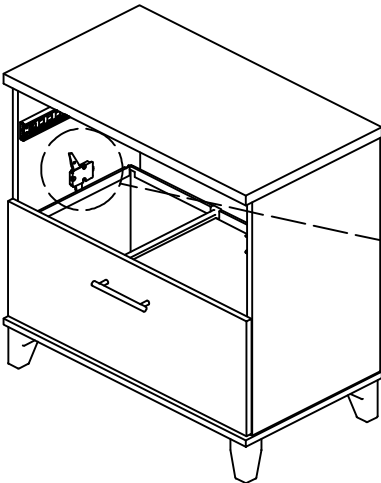

1

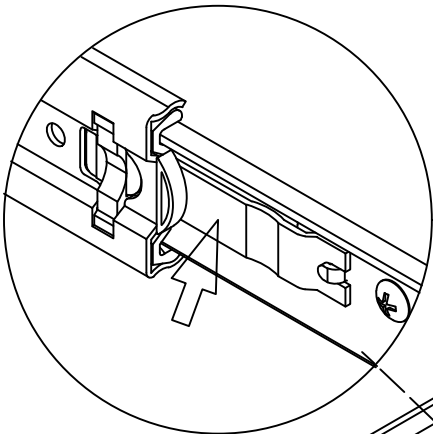
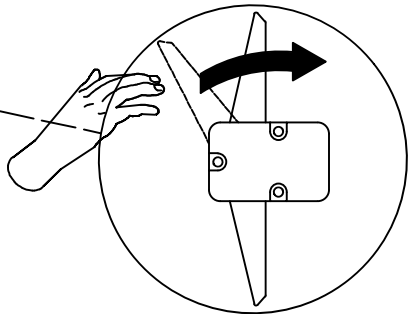

2

