

ASSEMBLY INSTRUCTION

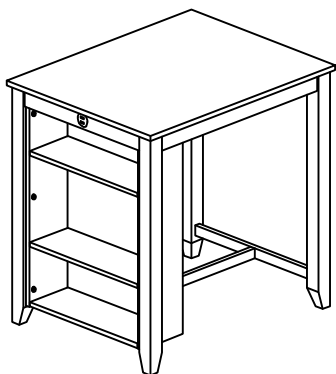

Thank you for purchasing this product. Please take time to read and follow instructions below. Check that you have all parts and hardware before assembly. Parts apparently missing are often found in packing materials. If you do not have all parts listed, call us and they be sent to you immediately



It is recommended to install protective pads under all legs and supports to avoid damage or scratches when placing furniture on a wood floor or other hard surface, and to limit indentation and prevent discoloration if placing on carpet.

PARTS LIST			
NO	SKETCH/	DESCRIPTION	Q'TY
A		TABLE TOP	1PC
B		CABINET FRAME	1PC
C		SHELF	3PCS
D		LEFT FRONT LEG	1PC
E		RIGHT FRONT LEG	1PC
F		LEFT BACK LEG	1PC
G		RIGHT BACK LEG	1PC
H		CENTER CROSS BAR	1PC
I		SIDE CROSS BAR	1PC

HARDWARE LIST				
NO	DESCRIPTION	SIZE	SKETCH	Q'TY
1	BOLT	Φ1/4"*25mm		8PCS
2	LOCK WASHER	Φ1/4"		8PCS
3	FLAT WASHER	Φ16*1mm		8PCS
4	BOLT	Φ5/16"*50mm		8PCS
5	LOCK WASHER	Φ5/16"		8PCS
6	FLAT WASHER	Φ19*1.5mm		8PCS
7	SHELD PIN	Ø6.2*7mm		12PCS
8	WOOD SCREW	Φ3.5*12mm		12PCS
9	WOOD SCREW	8#*35mm		4PCS
10	ALLEN KEY	4mm		1PC
11	DOWEL-WOOD	Φ3.5*12mm		4PCS
12	COVER	Φ30		8PC

Step 1

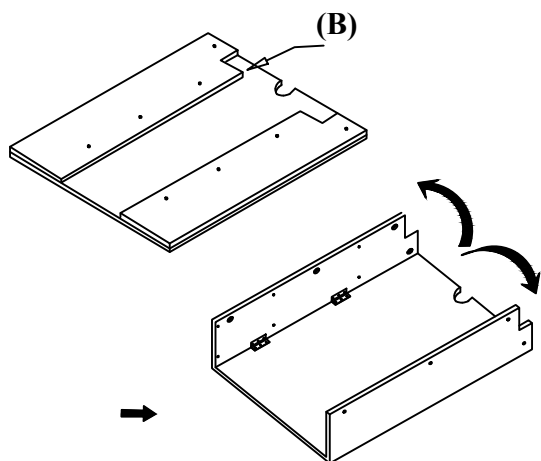

Step 2

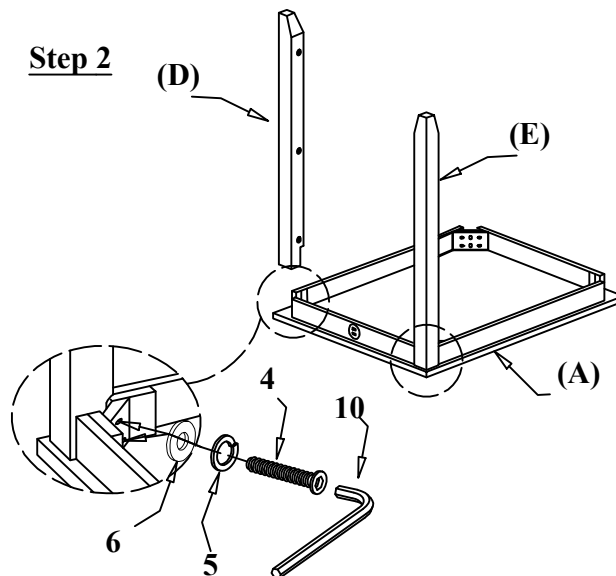

DO NOT TIGHTEN BOLTS UNTIL COMPLETELY ASSEMBLED.

Step 3

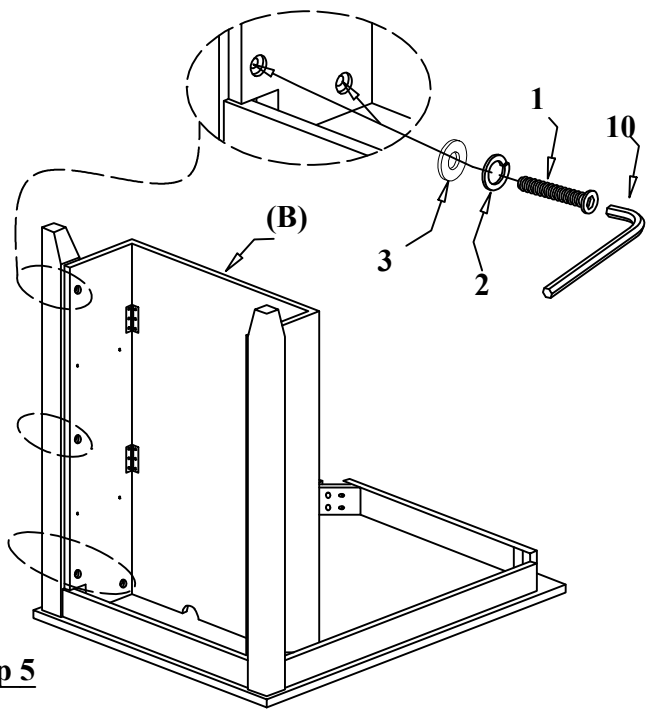

Step 4

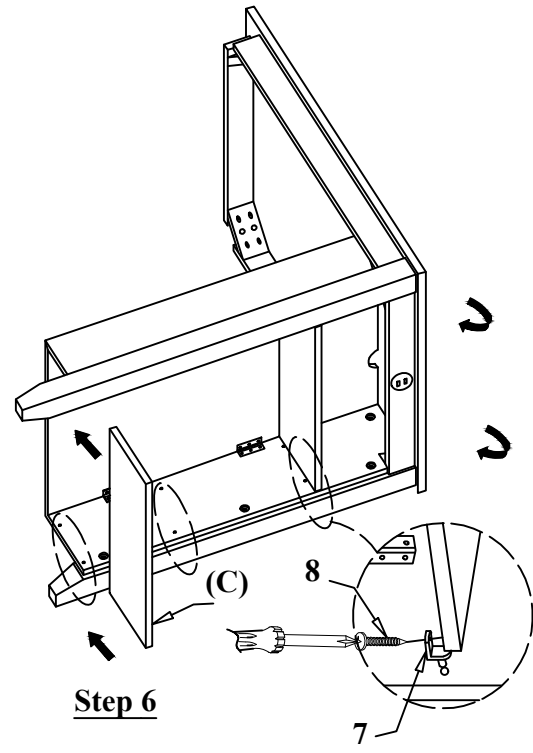

Step 5

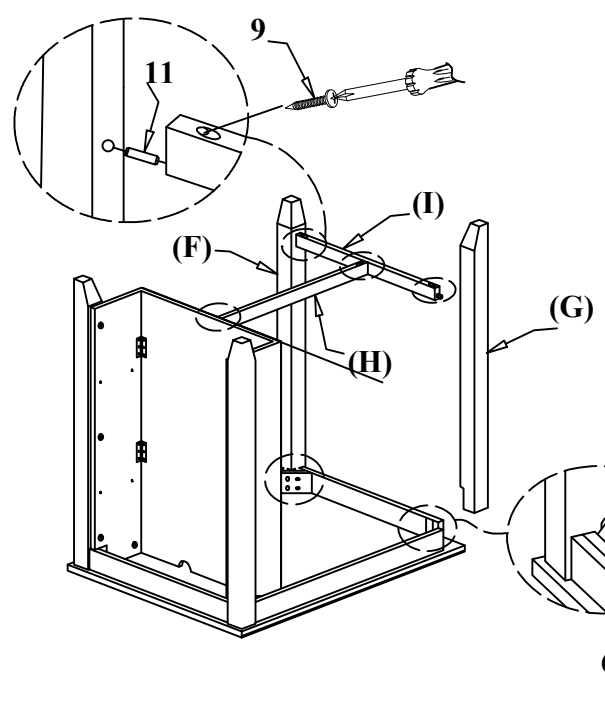

Step 6

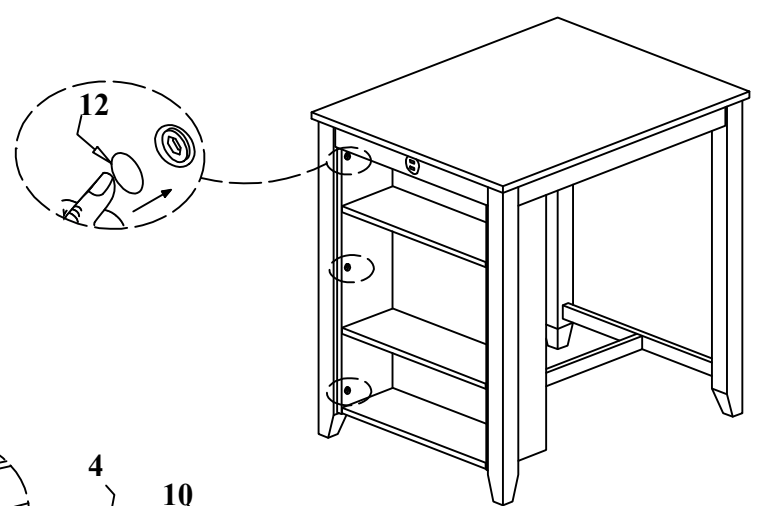

Step 7

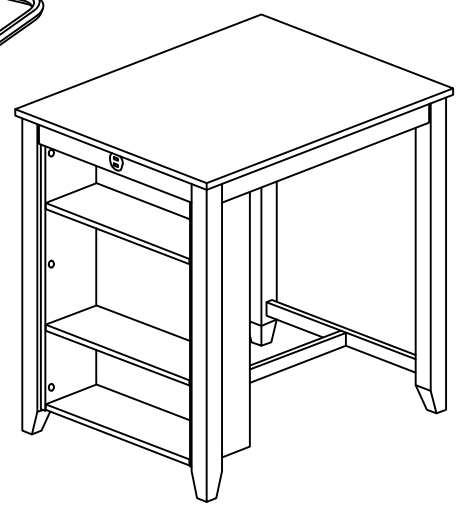

DO NOT TIGHTEN BOLTS UNTIL COMPLETELY ASSEMBLED.

ASSEMBLY COMPLETED