

# Assembly Instructions

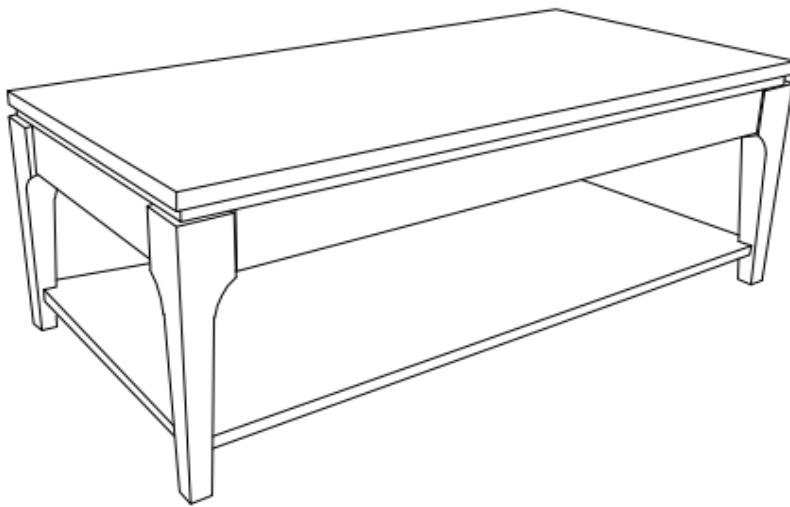

**Caution : You should read this before proceeding**

**Please look in the velcro pouch for hardware packs and legs**





## LIFT TOP COFFEE TABLE

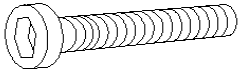

### Parts List

Label	Picture	Description	QTY
A		Table Top	1
B		Table Base	1
C		Table Leg	4

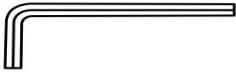
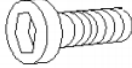



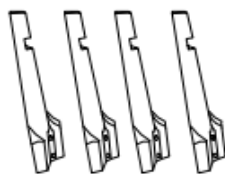

# Hardware

Label	Picture	Description	QTY
①		Long Bolt (M6*62MM)	9
②		Spring Washer (M6)	18
③		Flat Washer (M6x19mm)	18
④		Allen Key (M6mm)	1
⑤		Short Bolt (M6*16mm)	9
⑥		Angle iron (25*25*1.5mm)	4

# Assembly Preparation

Before Beginning Assembly:



-  x 9
-  x 18
-  x 18
-  x 1
-  x 9
-  x 4



- Read instructions, cover to cover-



- Have 2 adults on hand for assembly-



- Do not assemble on flooring or carpet-



- Assemble on a clean non-marring surface (packing foam)-



- Save all packaging until finished-

# Assembly Steps

## Overview

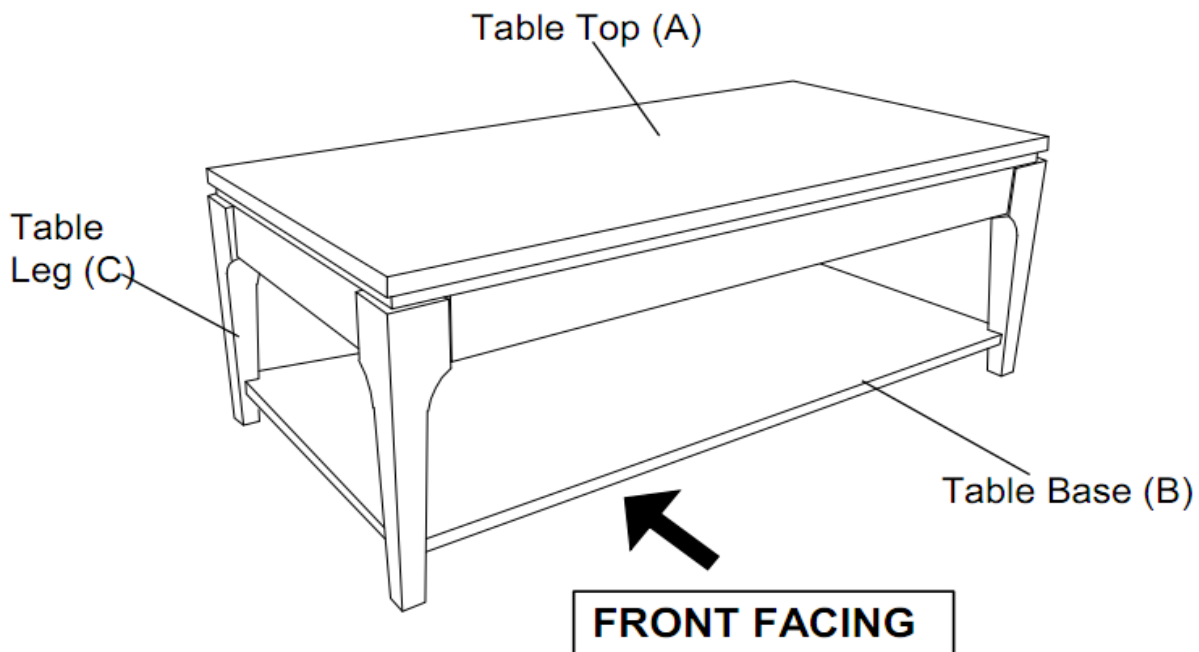

This Table has multiple parts and may require up to 30 minutes to assemble. To give you an overview of the Table parts, the above picture is provided to help you put the various parts into perspective. Please read through the instructions below to familiarise yourself with the parts and steps before assembly.

## Step 1

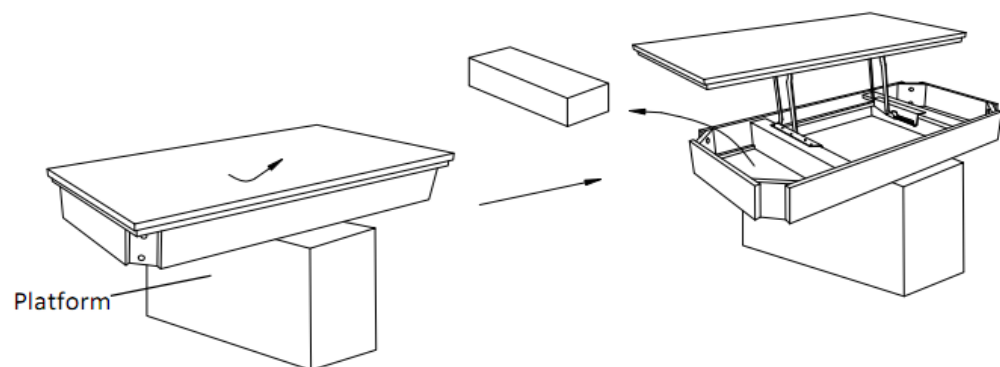

Please place the product on a platform.  
Lift up on the top of the Coffee Table to open, then take out the inner carton.

## Step 2

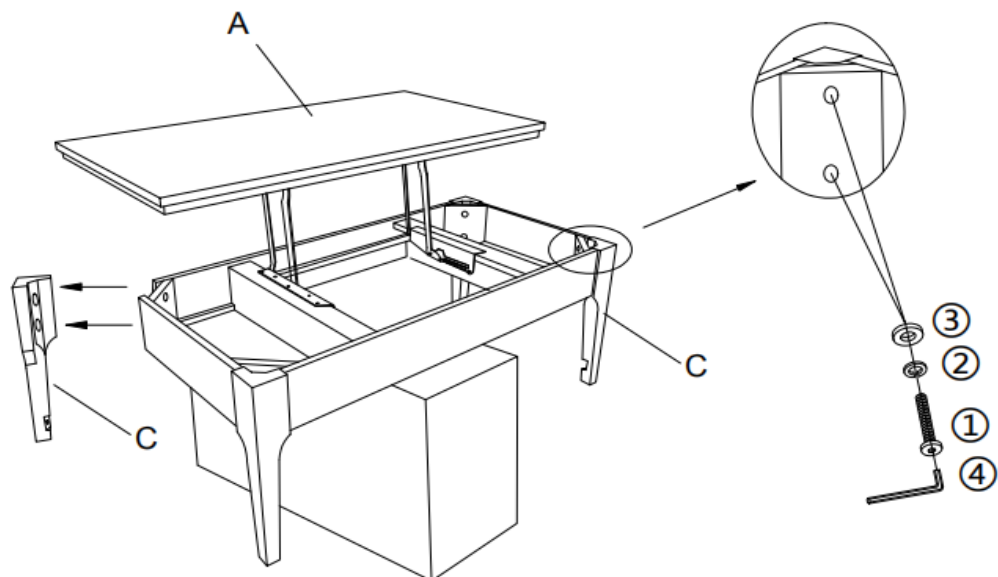

Find A flat case to hold A, then pull the lift panel open.  
Attach Table Legs(C) to Table Top(A) using Bolts(①), Spring Washers(②), Washers(③) and the Allen Key(④).  
Do not fully tighten the Bolts at this time.

## Step 3

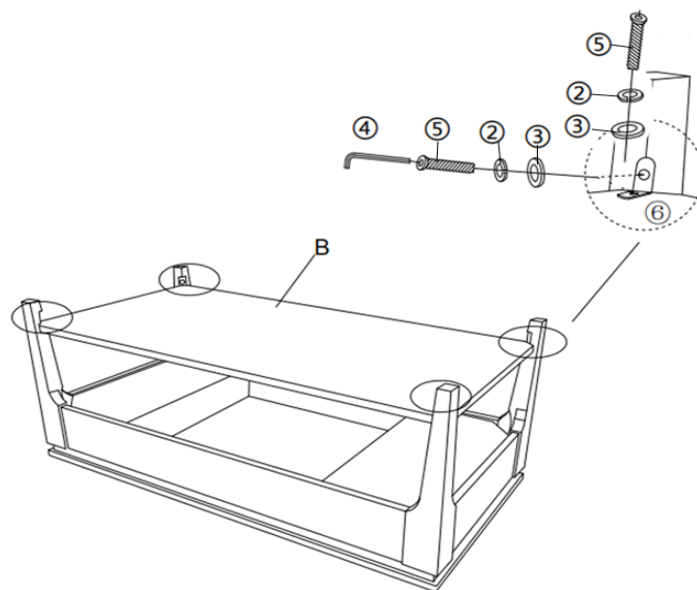

Place the Table Top(A) facedown onto a clean, non-marring surface. A helper should help hold B.

3.1) **With the help of another adult**, attach the Table Legs(C) to the Table Base(B) using Bolts(⑤), Spring Washers(②), Washers(③), the Angle iron(⑥) and the Allen Key(④).

Tighten all Bolts at all joints in a sequential manner.

## Step 4

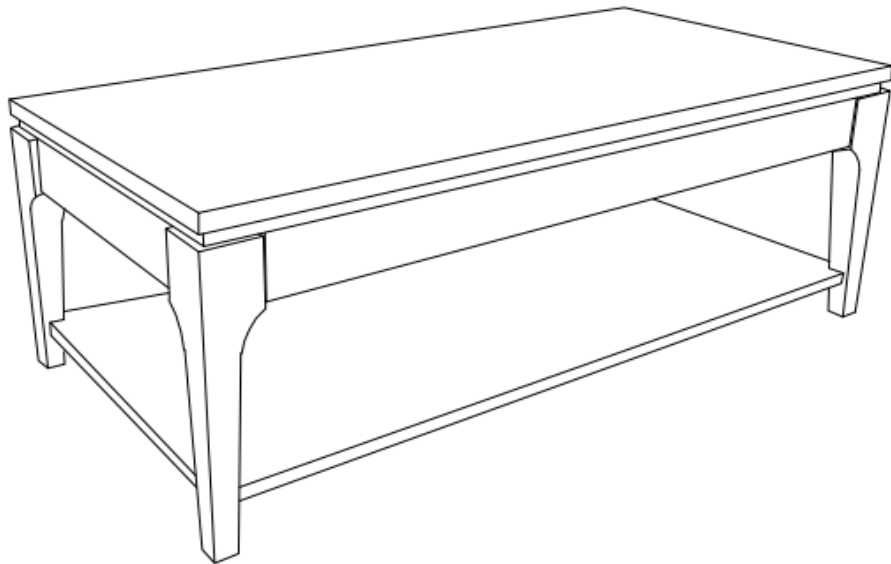



















**CAUTION 1:** When tightening these screws, tighten sequentially. If there are any wobbles after tightening, loosen the screws and execute this same process.



Ensure all screws are fully locked into position.

Your Table is ready for use.

This Table can only be used on a flat, level surface.

### Care & Maintenance

-   ● Do not put hot items directly on furniture surface
-   ● Do not clean furniture with harsh cleansers or polish.
-   ● Do not place furniture under direct sunlight.
-   ● Do not place furniture near heating or cooling vents.
-   ● Do not write on furniture without a padded barrier to protect the surface.
-   ● Do not place furniture outside . For indoor use only .
-   ● Not for commercial use. For residential use only .
-   ● Stains may be removed with mild soap solution and damp cloth.
-   ● Children should not climb or jump on the furniture.

- 
-   ● Dust and pick-up spills using a clean, non-colored, lint-free cloth .