

# Assembly | Asambla | Assemblage

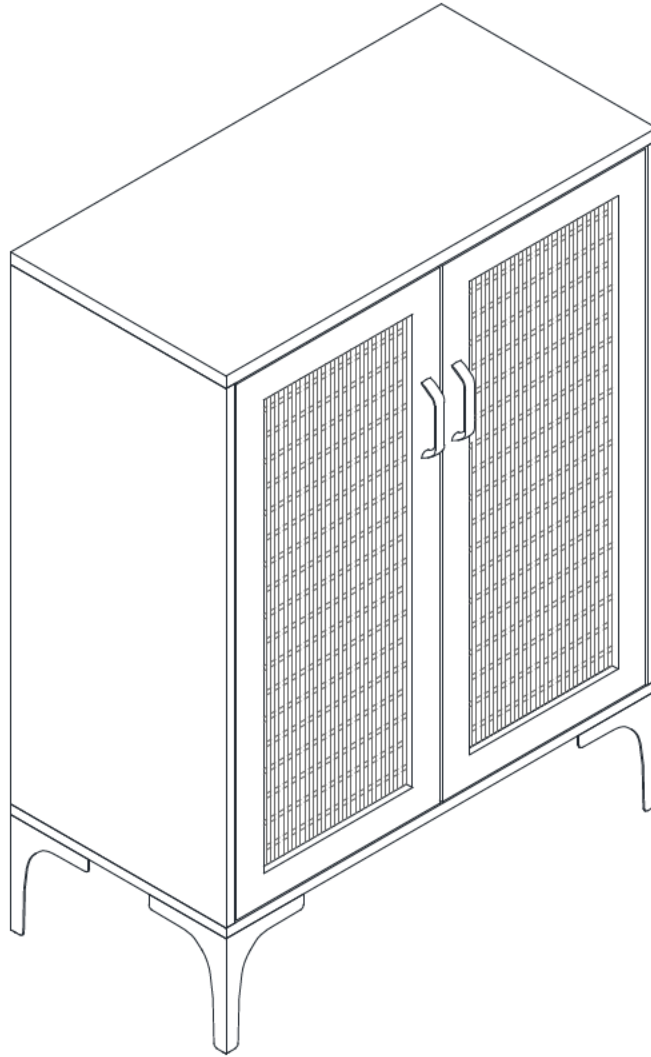

# Assembly | Asambla | Assemblage

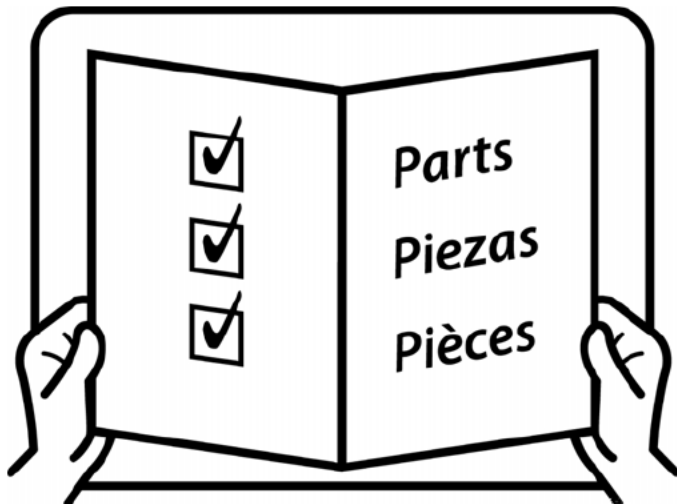
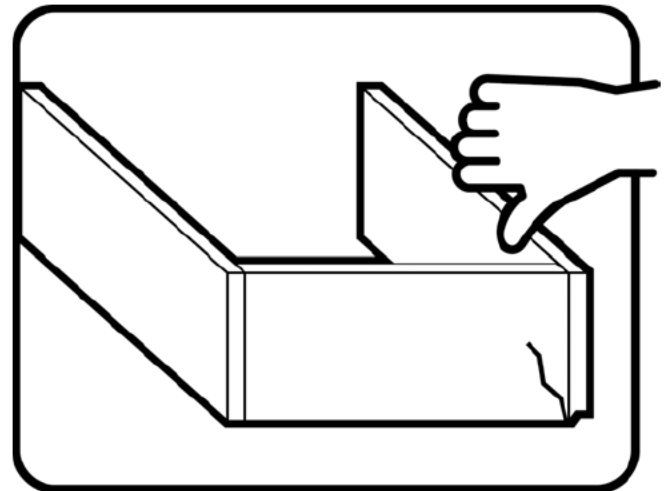
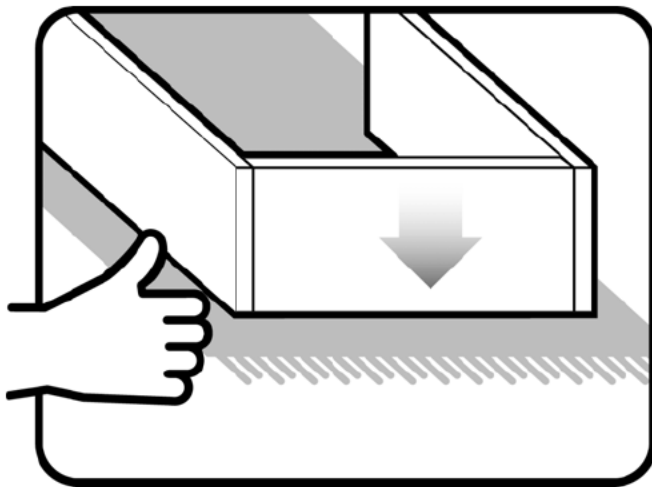
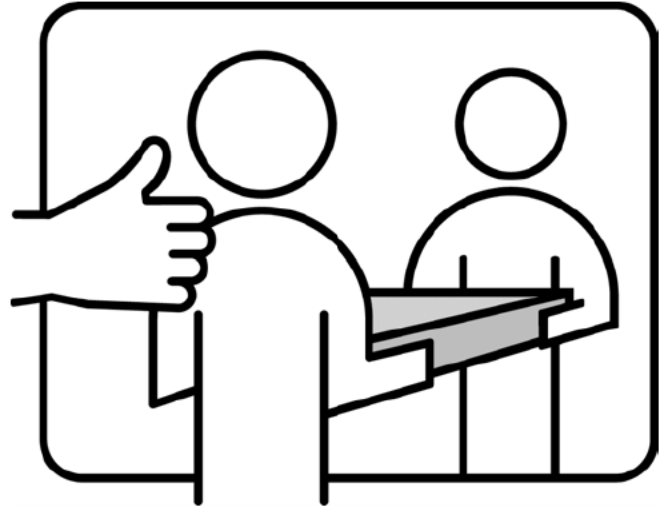
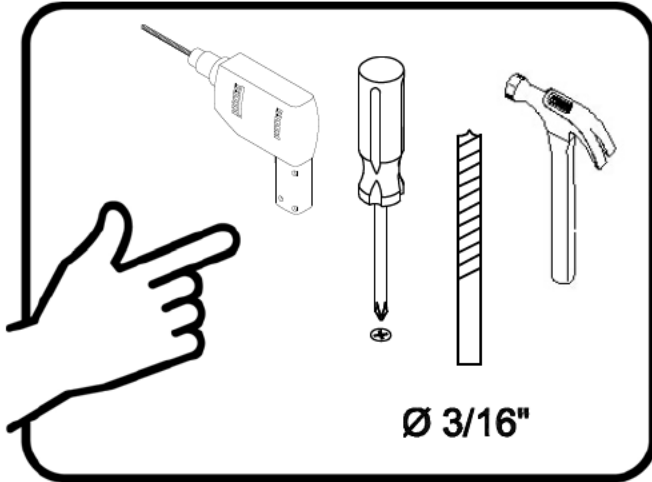

# Assembly | Asamblea | Assemblage

Techniques | Técnicas | Techniques

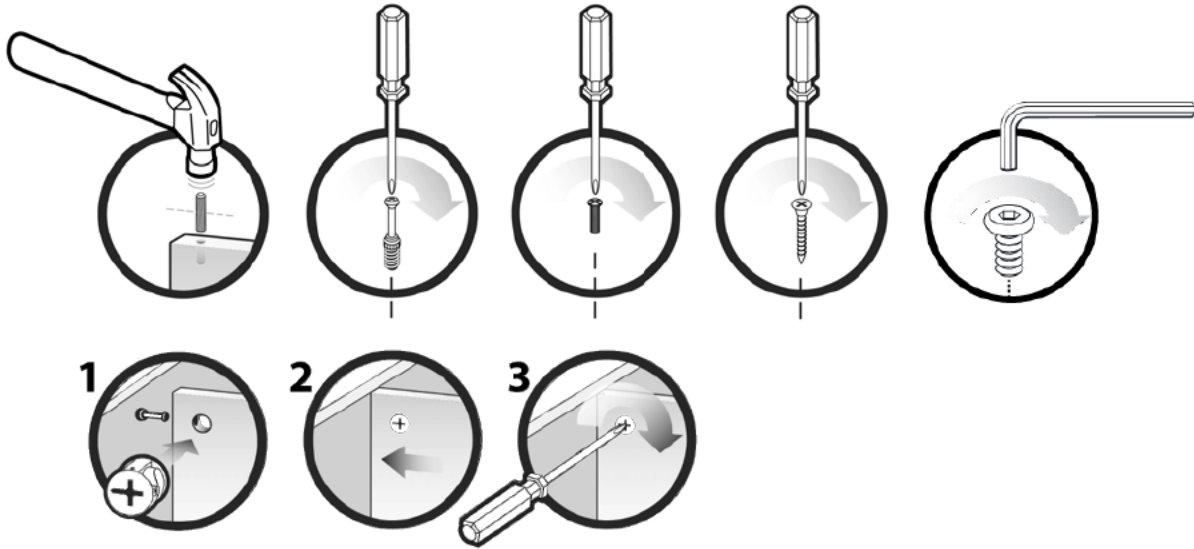

Care | Cuidado | Entretien







Safety | Seguridad | Sécurité



Note! | ¡Nota! | Remarque!

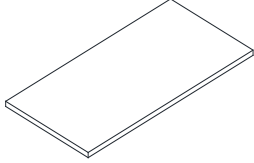
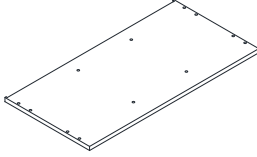

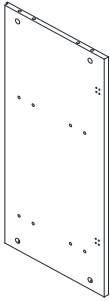
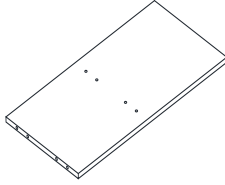

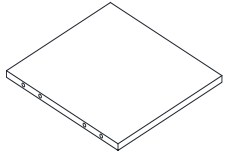
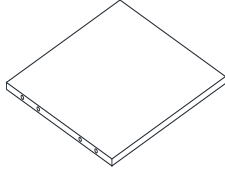
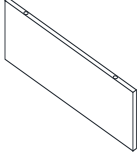
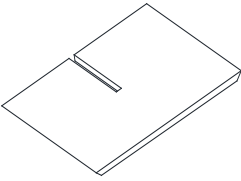
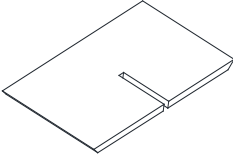
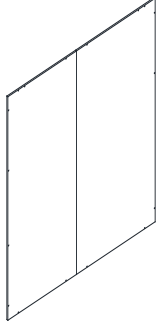

# Assembly | Asamblea | Assemblage

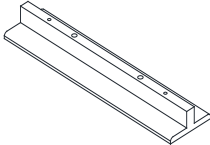
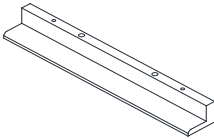
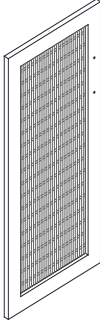
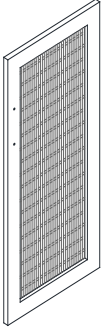
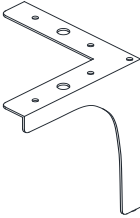
<p>A x1</p>  <p>Top panel Panel superior Panneau supérieur</p>	<p>B x1</p>  <p>Bottom panel Panel inferior Panneau du bas</p>	<p>C x1</p>  <p>Left panel Panel izquierdo Panneau de gauche</p>
<p>D x1</p>  <p>Right panel Panel derecho Panneau droit</p>	<p>E x1</p>  <p>Shelf panel Panel de estantería Panneau d'étagère</p>	<p>F x1</p>  <p>Middle vertical panel Panel vertical medio Panneau vertical central</p>
<p>G x1</p>  <p>Left shelf panel Panel de estante izquierdo Panneau d'étagère gauche</p>	<p>H x1</p>  <p>Right shelf panel Panel de estante derecho Panneau d'étagère droit</p>	<p>I x2</p>  <p>Partition panel Panel de partición Panneau de partition</p>
<p>J x1</p>  <p>Cross panel Panel transversal Panneau transversal</p>	<p>K x1</p>  <p>Cross panel Panel transversal Panneau transversal</p>	<p>L x1</p>  <p>Back panel Panel posterior Panneau arrière</p>

# Assembly | Asamblea | Assemblage

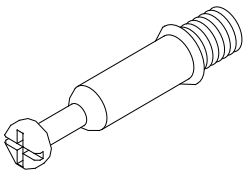
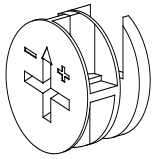
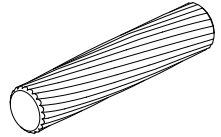
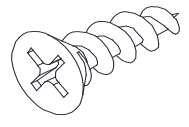
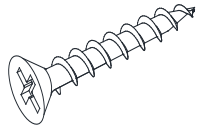
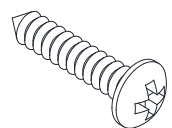
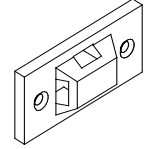
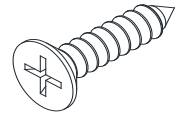
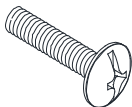
<p>M x2</p>  <p>Middle wood bracket Soporte de madera medio Support en bois moyen</p>	<p>N x2</p>  <p>Side wood bracket Soporte de madera lateral Support en bois latéral</p>	<p>O x1</p>  <p>Left door Puerta izquierda Porte gauche</p>
<p>P x1</p>  <p>Right door Puerta derecha Porte droite</p>	<p>Q x4</p>  <p>Iron leg Pierna de hierro Jambe de fer</p>	

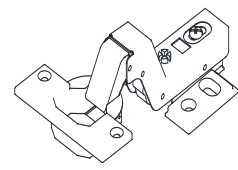
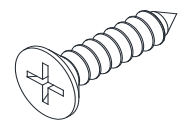
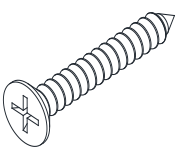
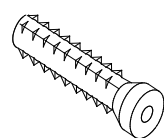
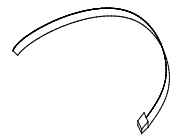
# Assembly | Asamblea | Assemblage

1	x24	2	x24	3	x40	4	x16
							
Cam bolt Perno de leva Boulon à came		Cam lock Bloqueo de leva Serrure à came		Wood dowel Clavija de madera Cheville en bois Ø5/16"x1-1/4"L		Screw Tornillo Vis Ø8#x1/2"L	
5	x8	6	x14	7	x4	8	x4
							
Screw Tornillo Vis Ø8#x1"L		Screw Tornillo Vis Ø1/8"*5/8"L		Bracket Soporte Support		Screw Tornillo Vis Ø1/8"*5/8"L	
9	x4	10	x2	11	x4	12	x24
							
Bolt Tornillo Boulon Ø5/32"*5/8"L		Handle Manija Poignée		Hinge Bisagra Charnière		Screw Tornillo Vis Ø1/8"*5/8"L	
13	x4	14	x4	15	x2	16	x12
							
Screw Tornillo Vis Ø1/8"*1-3/8"L		Anchor Ancla Ancre		Tie Lazo L'attache		Cover Tapa Couverture	

# Assembly | Asambla | Assemblage

1

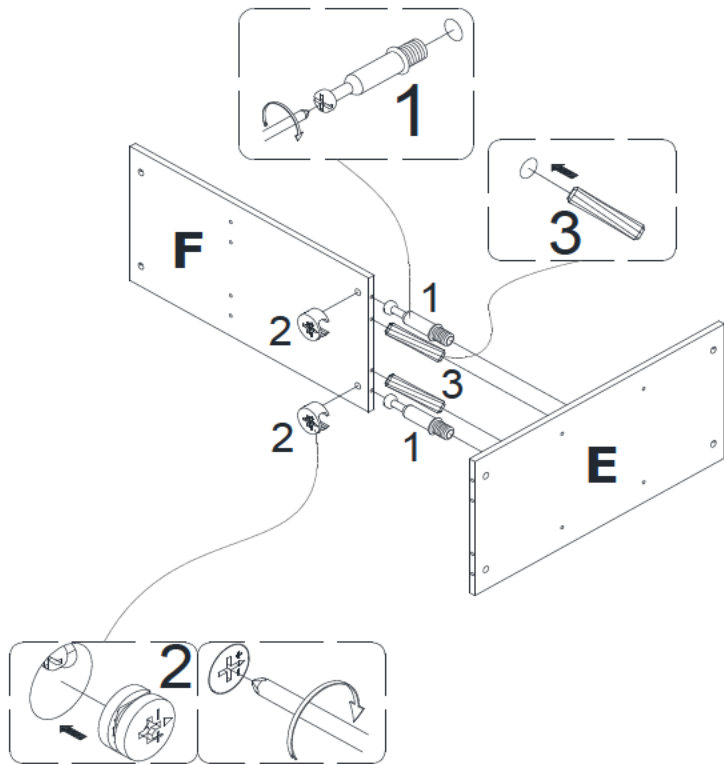

1		x 2
2		x 2
3		x 2

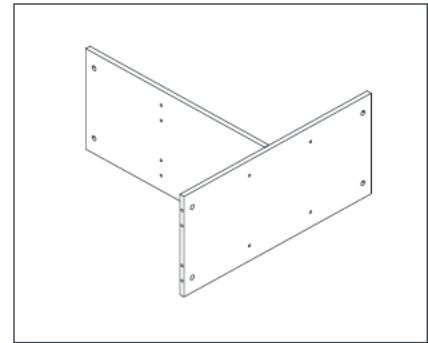

2

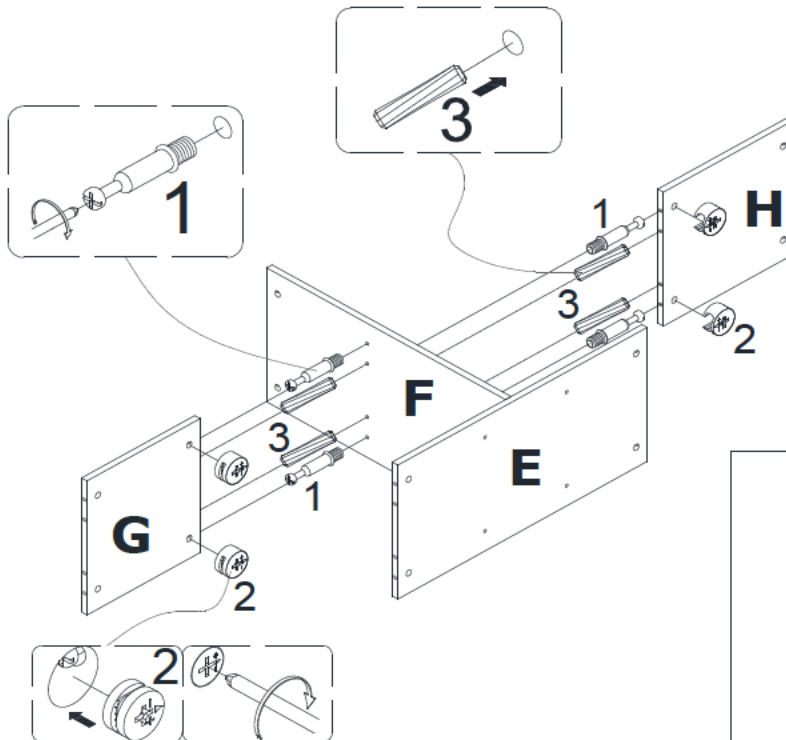

1		x 4
2		x 4
3		x 4

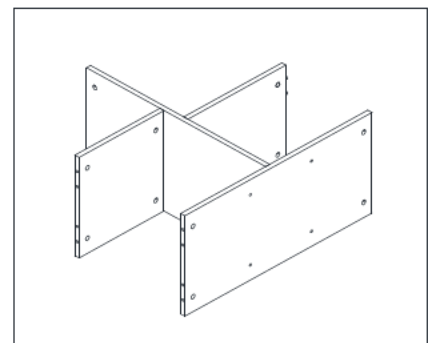

# Assembly | Asambla | Assemblage

3

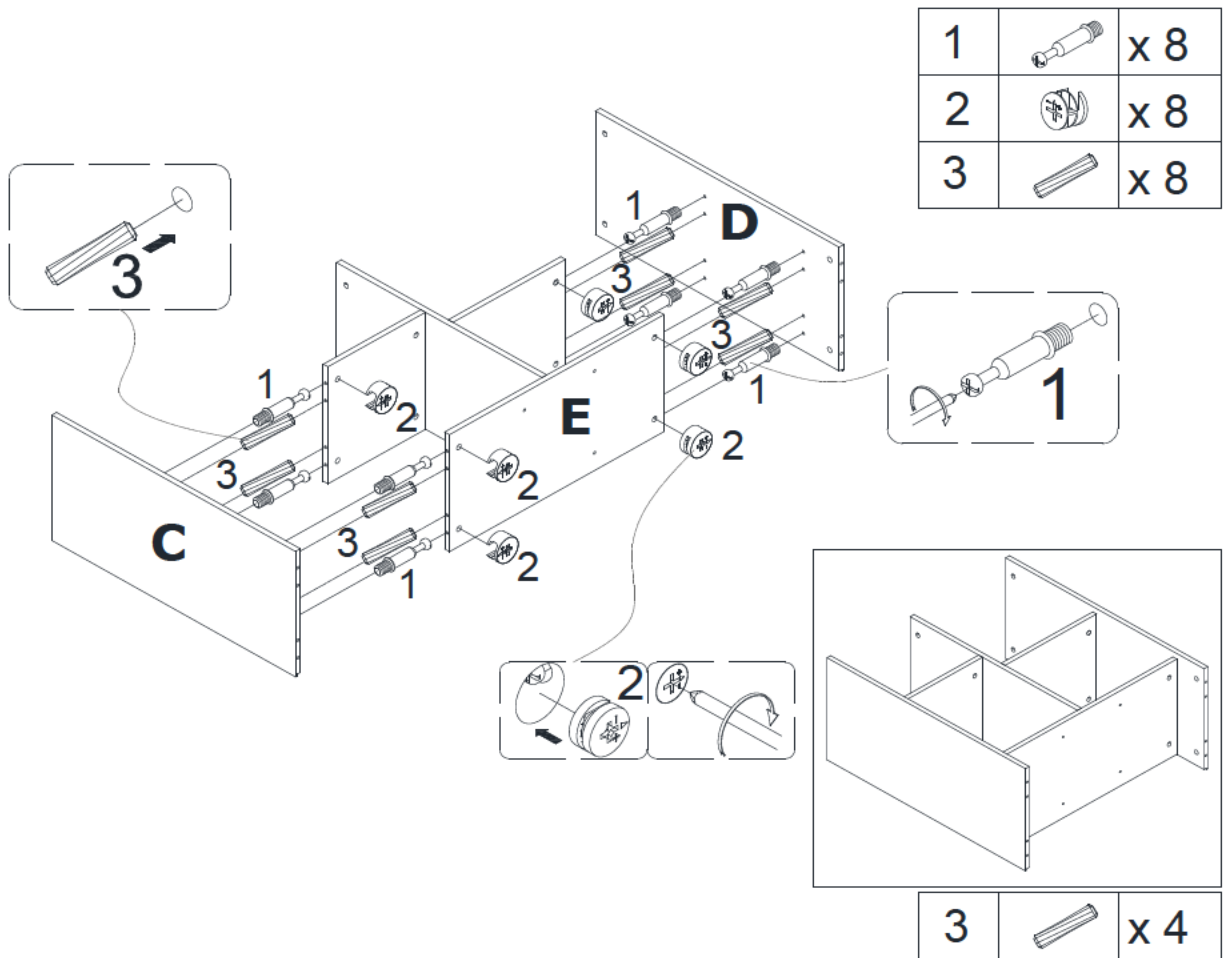

4

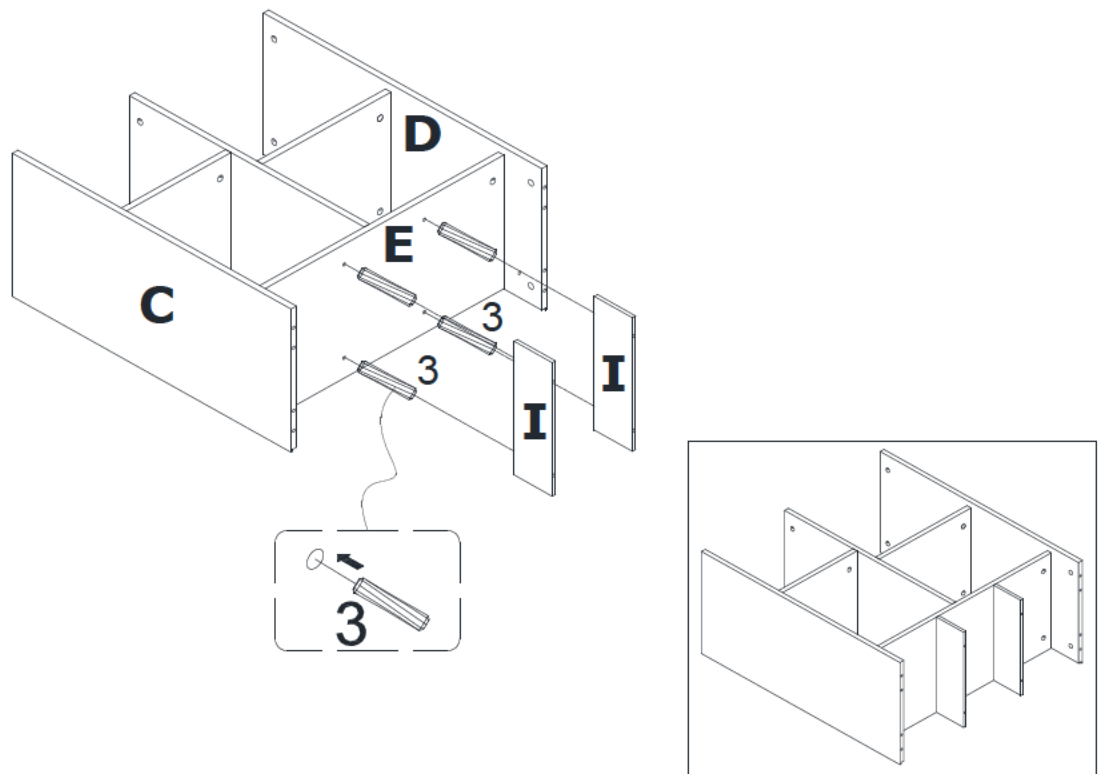



# Assembly | Asambla | Assemblage

5

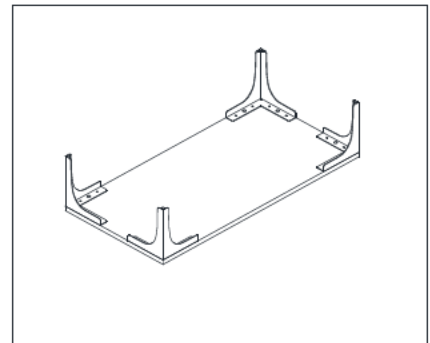
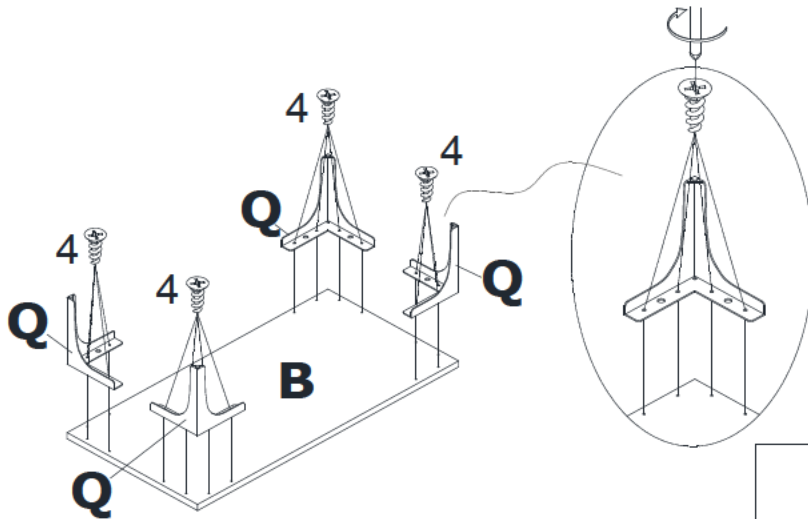
4		x 16
---	---	------



6

1		x 4
2		x 4
3		x 8

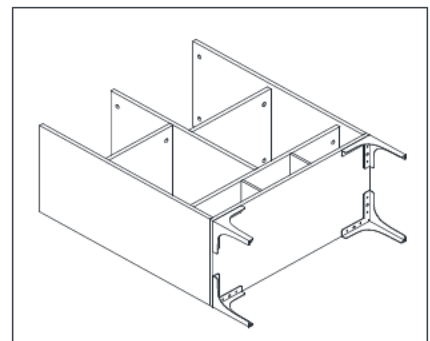
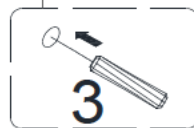
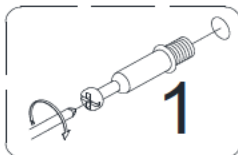
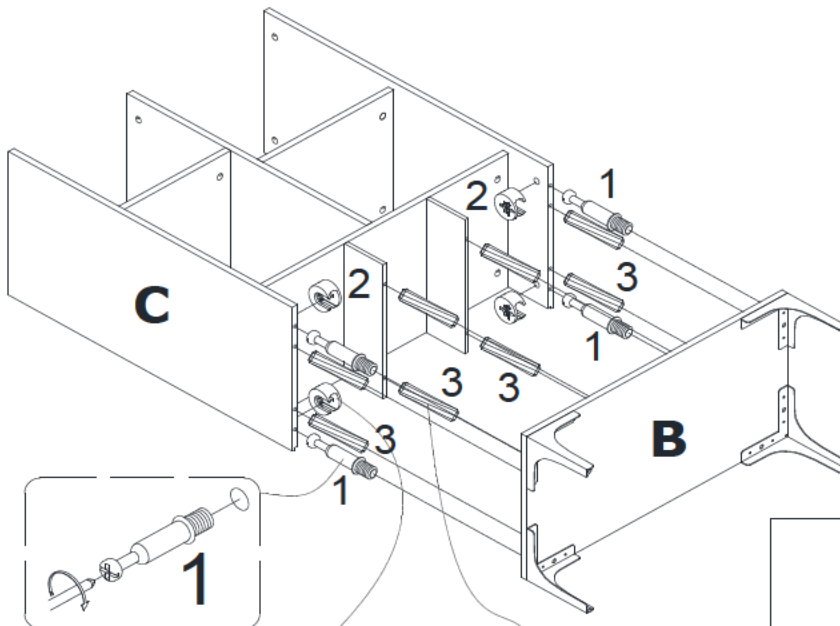

# Assembly | Asambla | Assemblage

7

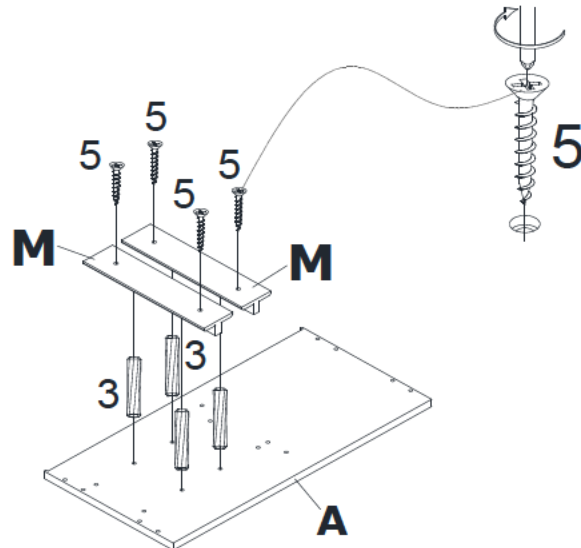

3		x 4
5		x 4

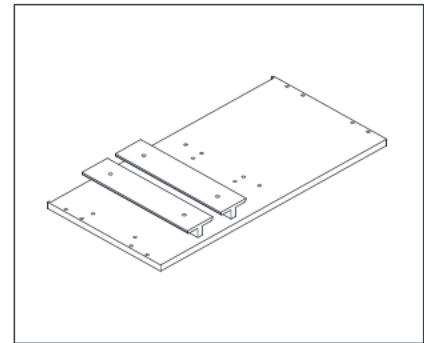

8

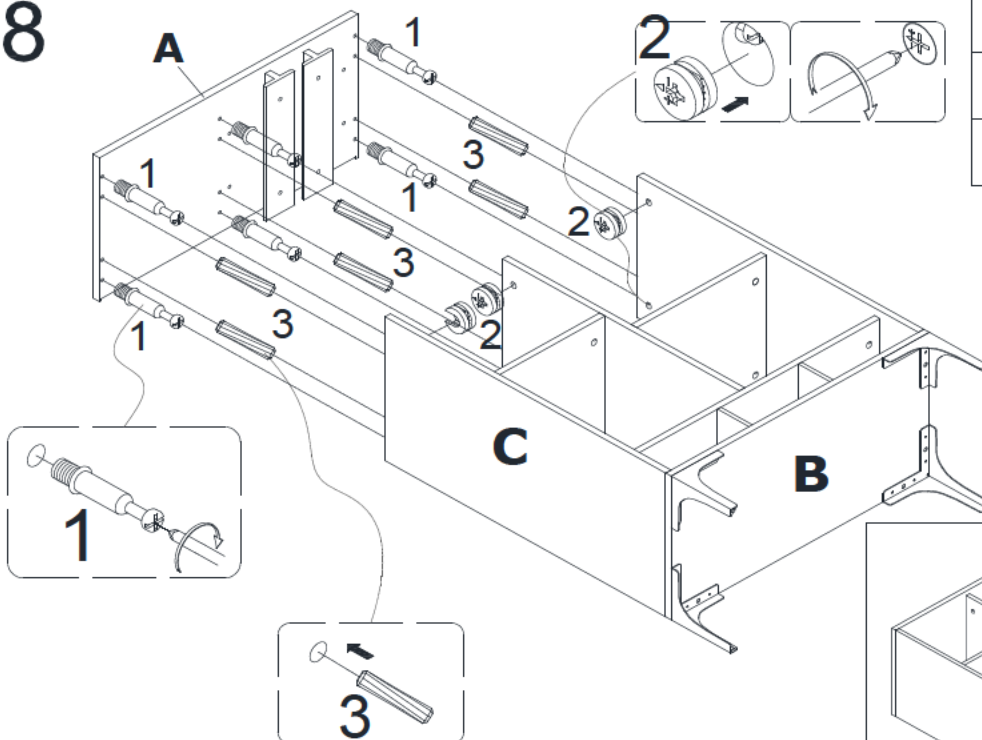

1		x 6
2		x 6
3		x 6

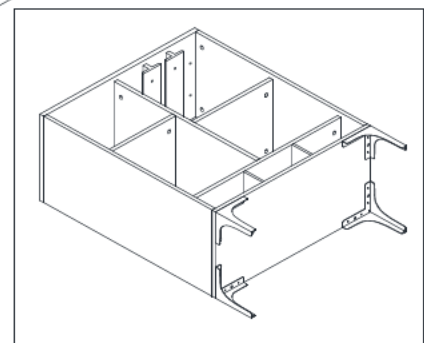

# Assembly | Asambla | Assemblage

9

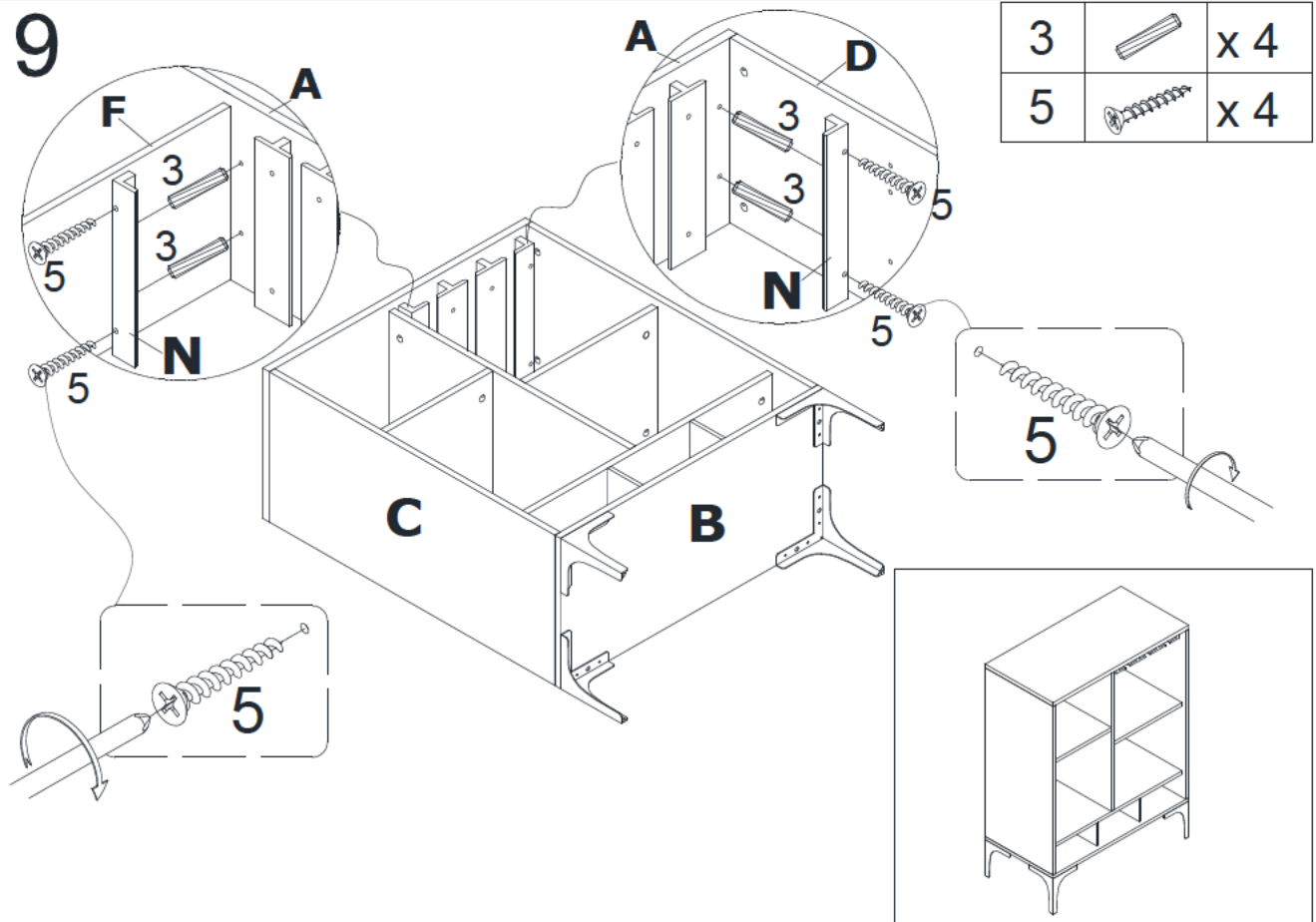

10

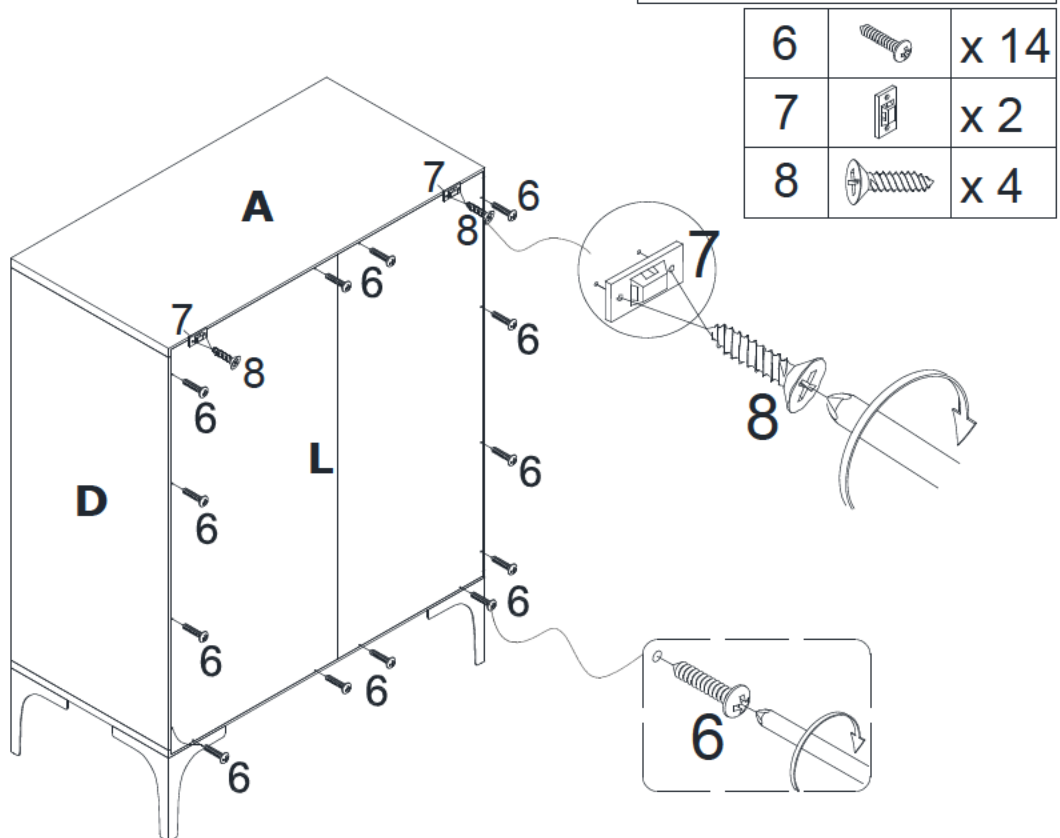

# Assembly | Asambla | Assemblage

11

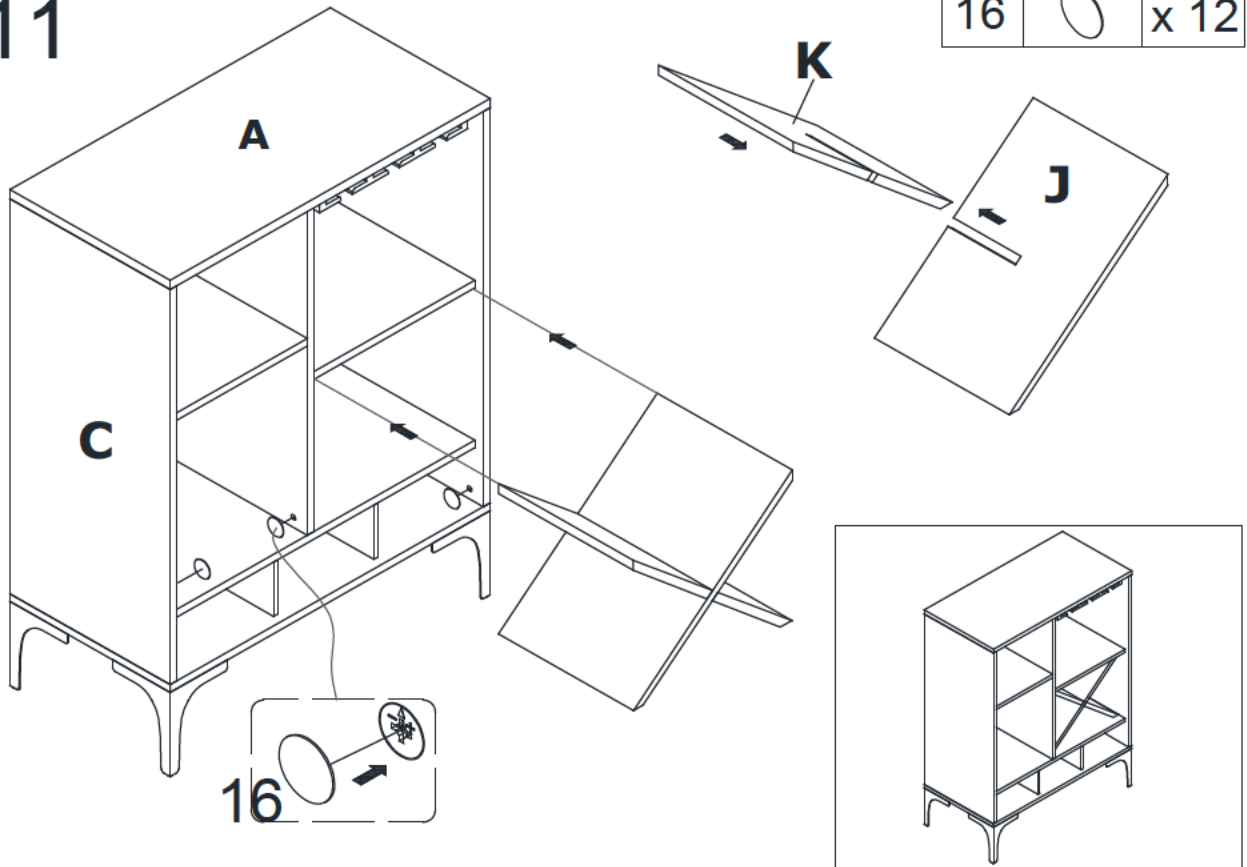



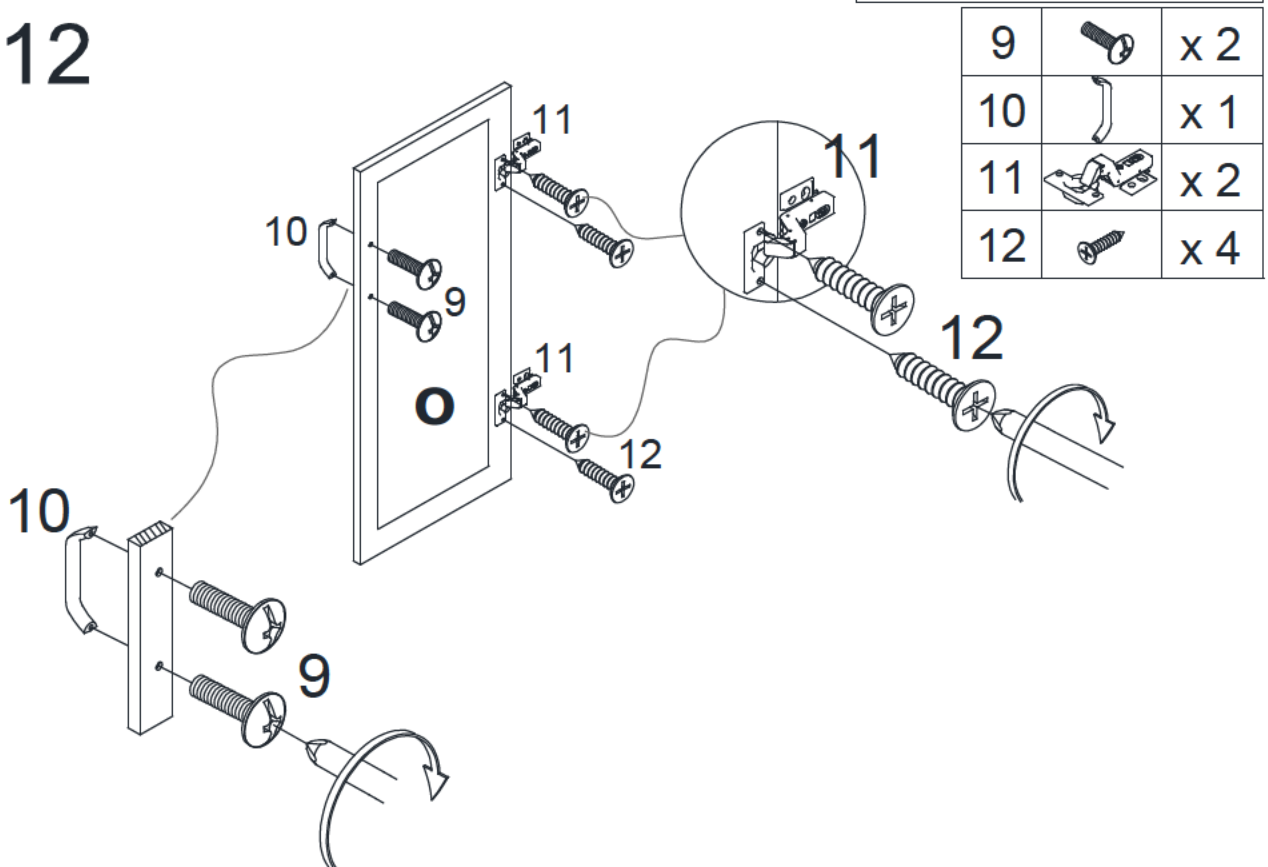

12

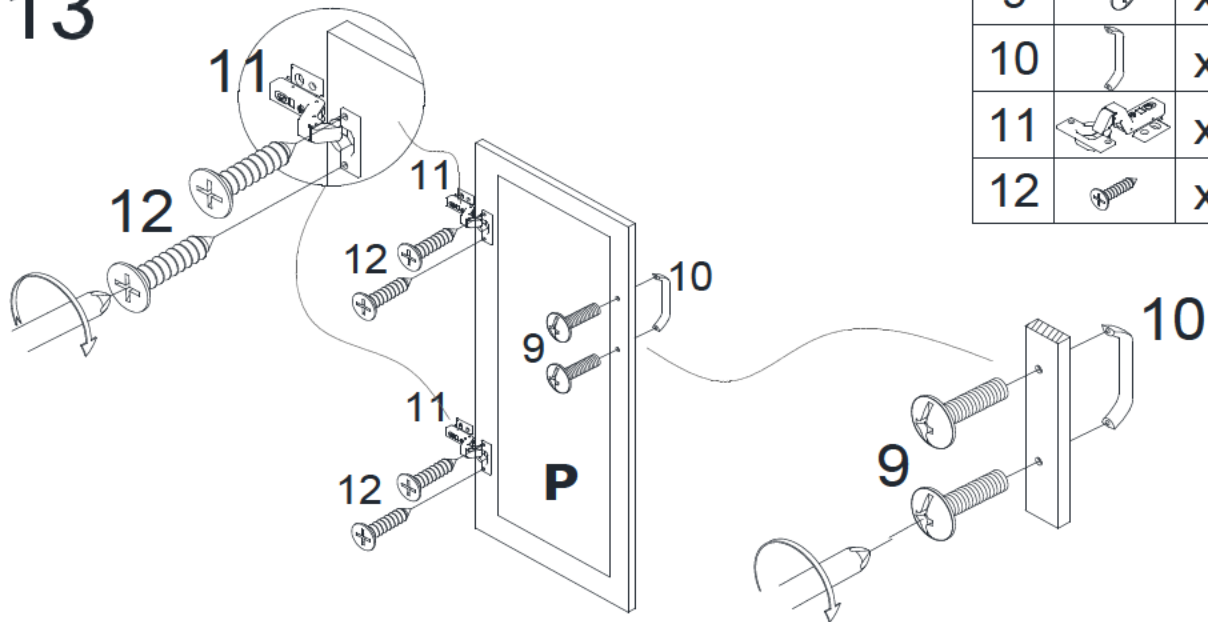

# Assembly | Asamblea | Assemblage

13



9		x 2
10		x 1
11		x 2
12		x 4

14

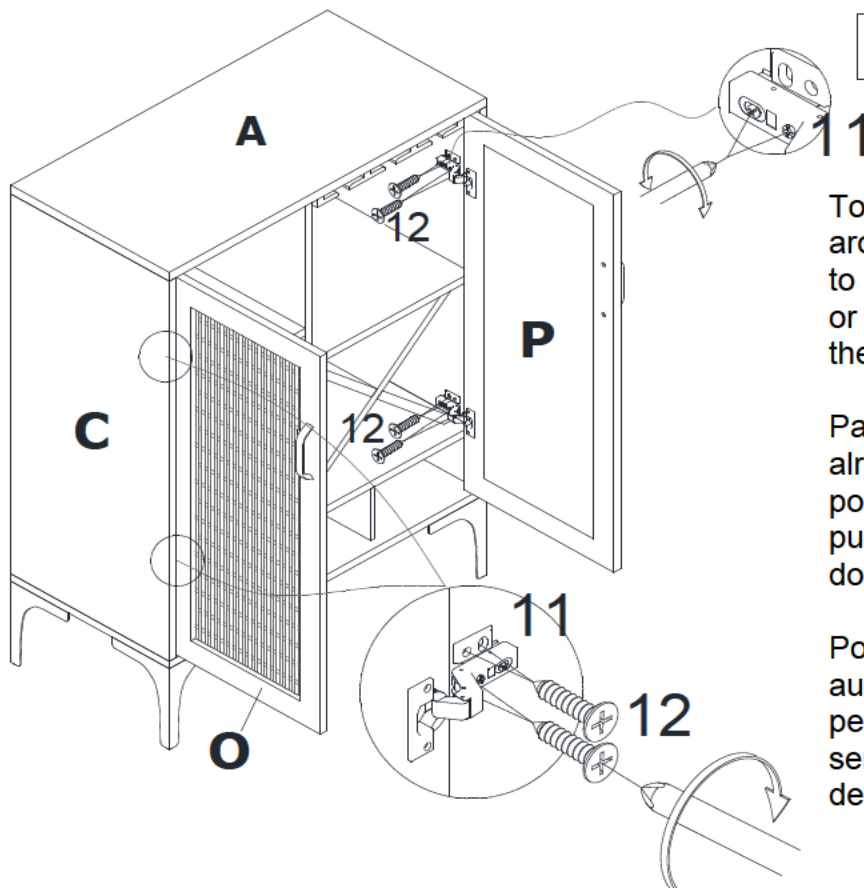

12		x 16
----	---	------

To achieve uniform clearance around the door, you may need to adjust the door by tightening or loosening the two screws on the hinge itself.

Para lograr un espacio uniforme alrededor de la puerta, es posible que deba ajustar la puerta apretando o aflojando los dos tornillos de la bisagra.

Pour obtenir un jeu uniforme autour de la porte, vous devrez peut-être ajuster la porte en serrant ou en desserrant les deux vis de la charnière.

# Assembly | Asamblea | Assemblage

15

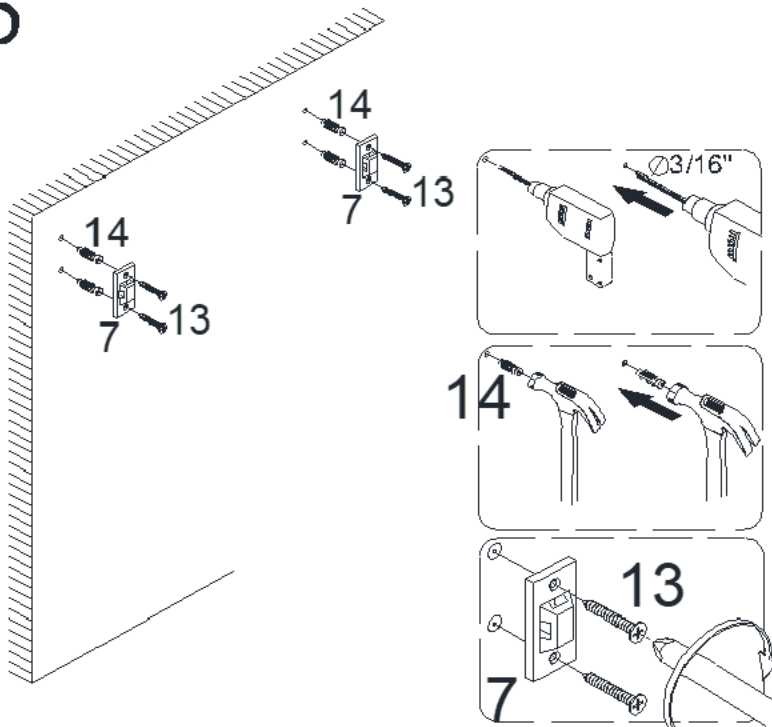

7		x 2
13		x 4
14		x 4

Anti-tipping hardware must be used for this product to avoid tipping and injury.

Se debe usar hardware antivuelco para este producto para evitar que se vuelque y se lesione.

Une quincaillerie anti-basculement doit être utilisée pour ce produit afin d'éviter tout basculement et blessure.

16

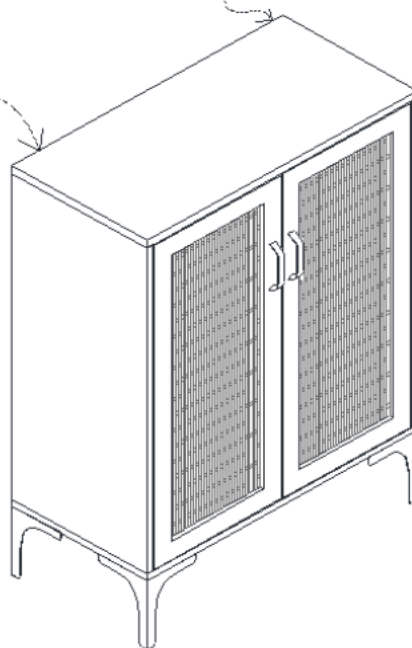
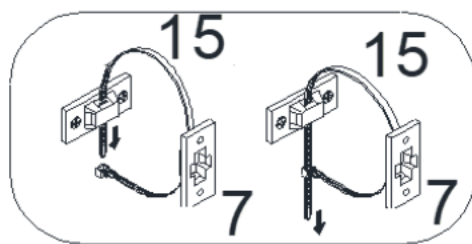

15		x 2
----	--	-----