



ASSEMBLY INSTRUCTIONS PHILLIPS BENCH ITEM# 42420

ASSEMBLY
REQUIREMENTS

2-Person
Assembly

45 Minutes
Assembly Time
(Approximate)

Thank you for purchasing our product!

Please refer and use this assembly instruction to assemble the product. Contact our customer service department in case there are any missing or damaged parts or hardware. Replacement parts are normally shipped within 2 or 3 days.

Email: replacementparts@buylateral.com
Within 30 days from delivery date

**PRODUCTS PURCHASED THROUGH OUR AUTHORIZED VENDORS ONLY
ARE ELIGIBLE FOR REPLACEMENT PARTS**

We appreciate your business!

**THIS PRODUCT IS FOR INDOOR AND HOUSEHOLD USE ONLY -
NOT FOR COMMERCIAL USE.**

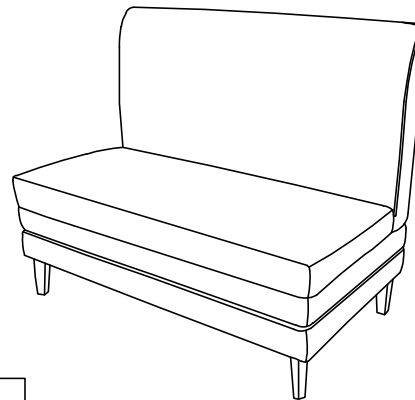

ASSEMBLY PREPARATION

1. Remove all packaging materials, staples and packing straps from the carton.
2. Refer to Parts List and Hardware List, and ensure parts and hardware are correct before assembly.
Contact customer service for missing parts.
3. Place all wooden parts on a clean, flat and soft surface (e.g. carpet or rug) to prevent scratch and damage to parts.

SAFETY PRECAUTION

1. KEEP ALL HARDWARE PARTS OUT OF REACH OF CHILDREN.
2. DISPOSE PLASTIC PACKAGING MATERIAL IMMEDIATELY TO AVOID ANY RISK OF SUFFOCATION TO CHILDREN AND ANIMALS.

TIPS FOR ASSEMBLY



1. Allow ample room for assembly and in close proximity to where product will be placed.
2. Assemble the product on a surface that does not scratch or damage the exterior gloss and finish of the furniture.
3. Identify all of the parts, hardware and quantities required for each step.
4. During assembly, do not over-tighten any fittings as this may cause damage.
5. DO NOT USE POWER TOOLS TO ASSEMBLE THIS PRODUCT.
6. Always place the product on a flat, level surface.
7. Do not sit or stand on the partially assembled product; only use the product for which it is intended.

CARE AND MAINTENANCE

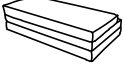

- Wipe clean with a soft, dry cloth; avoid the use of harsh chemicals or household cleaners as they may damage the exterior finish of the furniture.
- **Hardware may loosen over time. Periodically, check that all connections are tight; re-tighten as necessary.**
- Solid wood is impacted by heat and humidity fluctuations which may cause small joint separations or hairline cracks; place the furniture away from direct sunlight and air conditioning vents, heating vents or units to protect the furniture.

ASSEMBLY INSTRUCTIONS PHILLIPS BENCH ITEM# 42420

PARTS LIST

ITEM	PART NAME	QTY
1	BACK REST 	1
2	SEAT 	1
3	LEG 	4

HARDWARE LIST

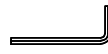
ITEM	HARDWARE NAME	DESCRIPTION	QTY	EXTRA
A	JCBB BOLT M8 X 50MM		6	1
B	FLAT WASHER		6	1
C	ALLEN KEY M5		1	-

** Extra Hardware for spare use

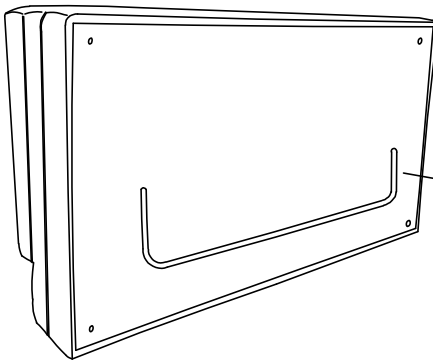

Uncover flap on bottom-side of Seat to access Legs and Hardware Pack.

STEP 1

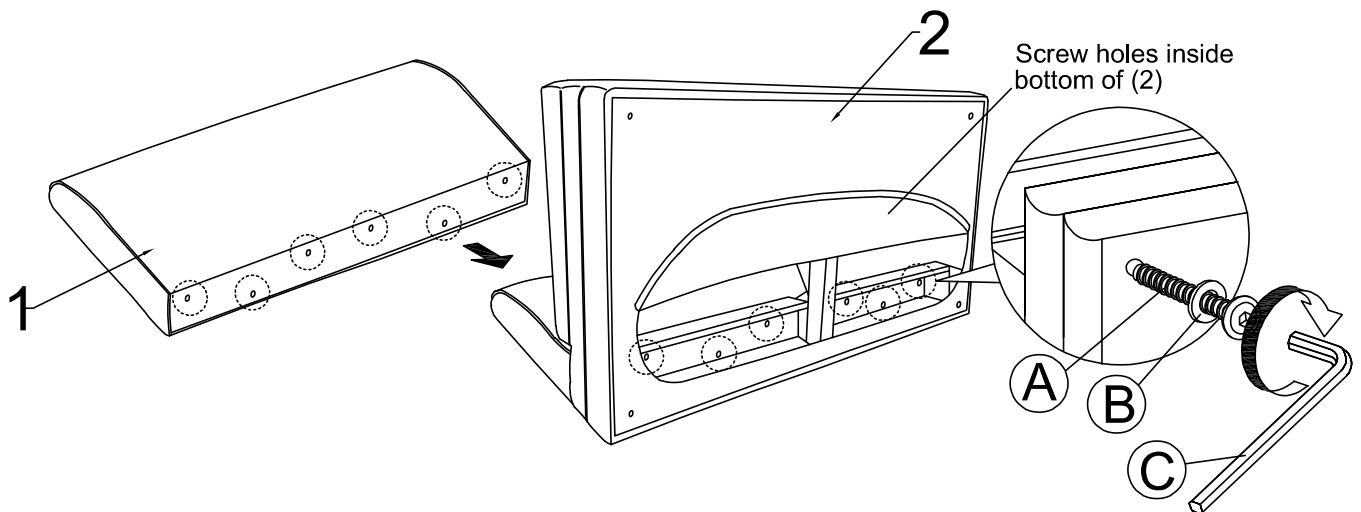

- Lay Back Rest (1) flat on a material that does not scratch the part.
- With assistance, position the back edge of Seat (2) perpendicular to the bottom edge of (1) as shown, and uncover the bottom flap.
- Align the bolt holes on both parts and use JCBB Bolt (A) fitted with Flat Washer (B) to fasten (2) to (1).
- Use Allen Key (C) to drive (A). Do not tighten (A) completely until all the bolts are in place.
DO NOT OVER-TIGHTEN THE BOLTS.
- Put the bottom flap back in place.

STEP 2

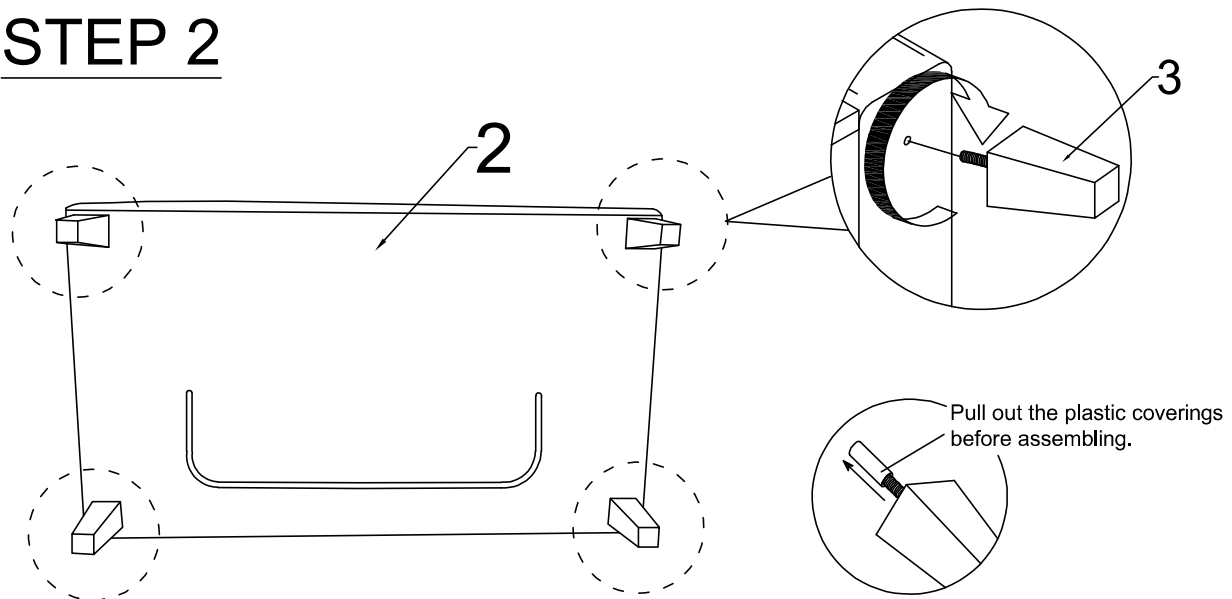

- Locate each screw hole at each corner on the bottom side of Seat (2).
- The screws on the legs are protected by plastic coverings. Please pull out the plastic coverings before assembling the legs to the bench.
- Screw in each Leg (3) by turning it in a clockwise direction by hand until each leg fits snugly to the seat bottom.
- With assistance, set the bench right-side up when all 4 legs are installed.

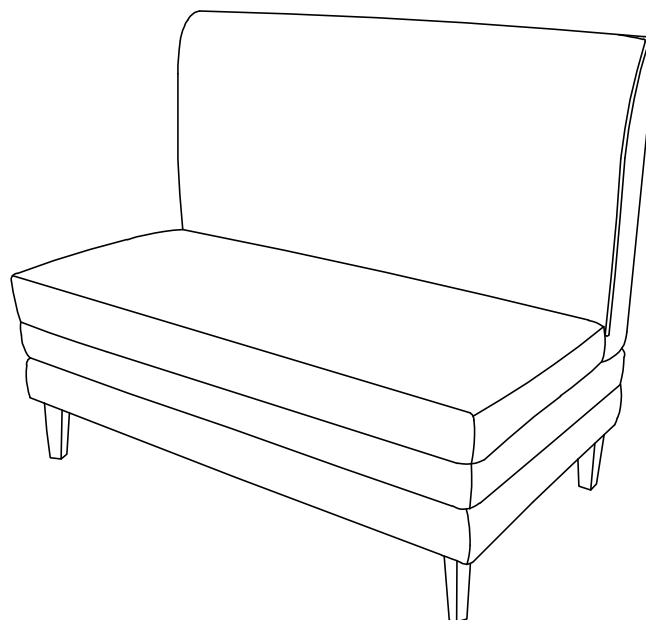

The assembly of the bench is complete.