

STEP 4

Insert Plastic Pin & Nut (3) into the pre-drilled holes of Panel (H).

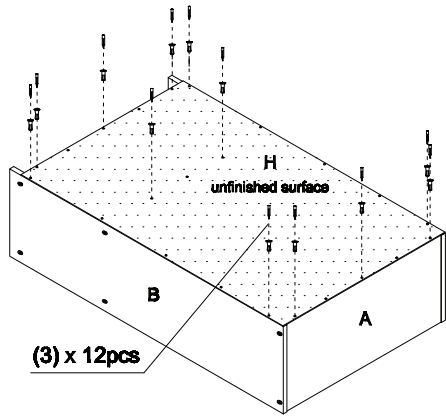

STEP 5

Insert Plastic Stopper (2) into the balance of pre-drilled holes of Panel (H).
To disassembled Plastic Pin(3), use a small stick, push it downwards.

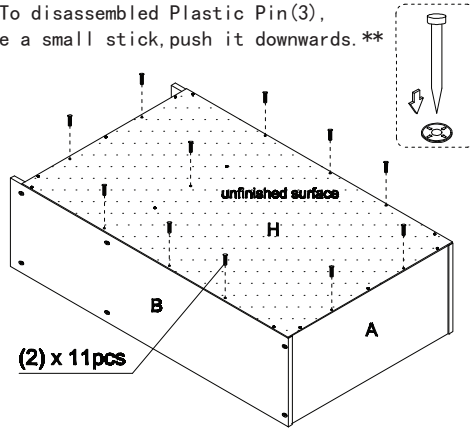

STEP 6

Insert Shelf Support (5), as shown.

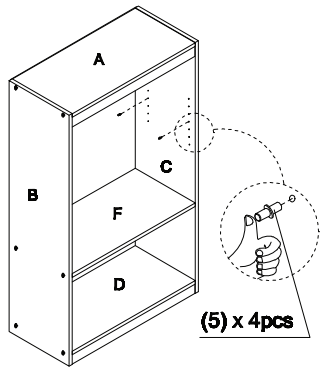

STEP 7

Lay Panel (E) to the Shelf Support (5).

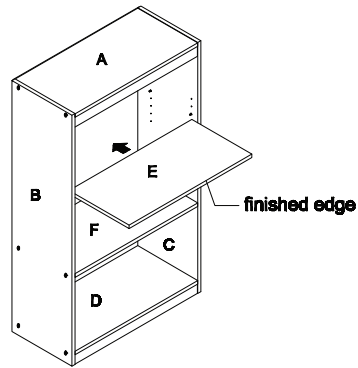

Recommended Maximum Weight

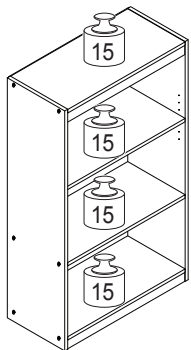

*Unit in Pound(lbs)

WARNING:

>This unit has been designed to support the maximum loads shown. Exceeding these load limits could cause sagging, instability, product collapse, and/or serious injury.

>DO NOT allow children to climb on unit.

>Put heavier items on lower shelves.

Assembly Instruction

No Tools Concepts 3-Tier Heavy Duty Bookcase

DIMENSION : 24.5"(W) x 41.3"(H) x 11.4"(D)

00:30

Approx. 30 minutes





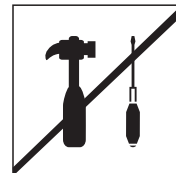



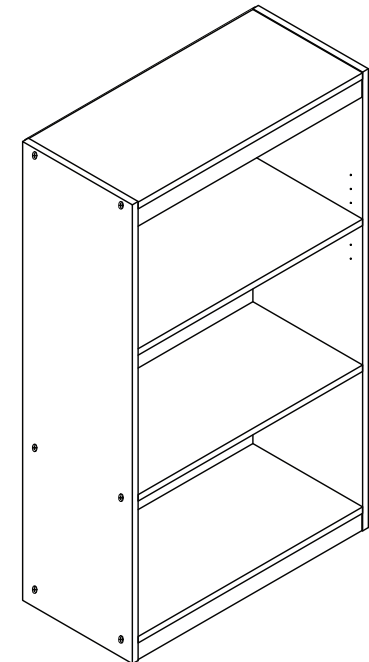





Recomm. 1 Person



Tool Required



No	Hardware List	Qty
1	Plastic Dowel 	20pcs
2	Plastic Stopper 	11pcs
3	Plastic Pin/Nut 	12pcs
4	Click Screw/Nut 	12pcs
5	Shelf Support 	4pcs

No	Parts List	Qty
A	Top Panel 	1pcs
B	Left Side Panel 	1pcs
C	Right Side Panel 	1pcs
D	Bottom Panel 	1pcs
E	Adj. Shelf Panel 	1pcs
F	Fix Shelf Panel 	1pcs
G	Cross Bar 	2pcs
H	Back Panel 	1pcs

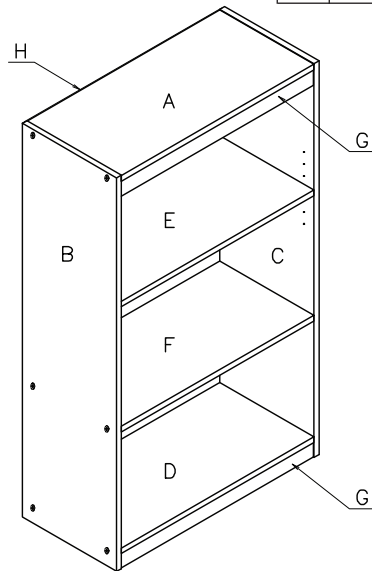

USEFUL HINTS BEFORE YOU START:

1. Read each step carefully before starting.
2. It is important that each step is performed in correct order to avoid difficulties.
3. Identify, sort and count the parts before assembly.
4. Assemble your furniture on packaging cardboard to prevent scratch or damage.
5. Clean the product with mild cleanser using soft damp cloth. Do not use harsh or abrasive cleanser.
6. Using incompatible hardware might cause damage to product.

STEP 1

- 1.1 Insert Dowel (1) to the pre-drilled holes of Panel (A) (B) (C) & (D).
- 1.2 Attach Panel (G) to Panel (A) & (D).

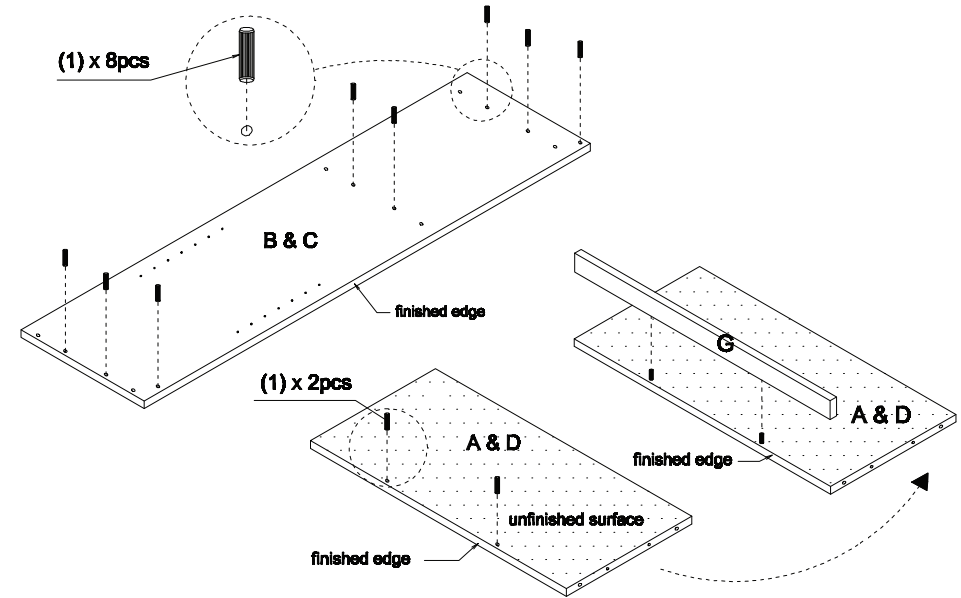

STEP 2

- Attach Panel (A) (D) & (F) to Panel (B) using Click Screw & Nut (4).
 Note: Please ensure all panels attached completely, no gap between them.

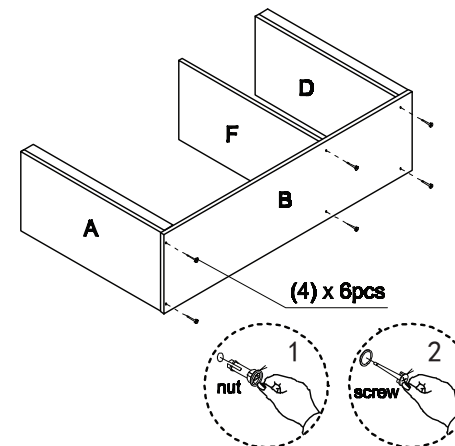

STEP 3

- Attach Panel (C) to the assembled unit using Click Screw & Nut (4).
 Repeat the same method as in Step 2.

