

ASSEMBLY INSTRUCTIONS

3-piece Polly Upholstered Dining Set Bench

ASSEMBLY
REQUIREMENTS

2-Person
Assembly

30 Minutes
Assembly Time
(Approximate)

Tools Required
(Not Provided)

Phillips Screwdriver

Flat Screwdriver

Thank you for purchasing our product!

Please refer and use this assembly instruction to assemble the product. Contact our customer service department in case there are any missing or damage parts or hardware. Replacement parts are normally shipped within 2 or 3 days.

PRODUCTS PURCHASED THROUGH OUR AUTHORIZED VENDORS ONLY ARE ELIGIBLE FOR REPLACEMENT PARTS.

We appreciate your business!

THIS PRODUCT IS FOR INDOOR AND HOUSEHOLD USE ONLY - NOT FOR COMMERCIAL USE.

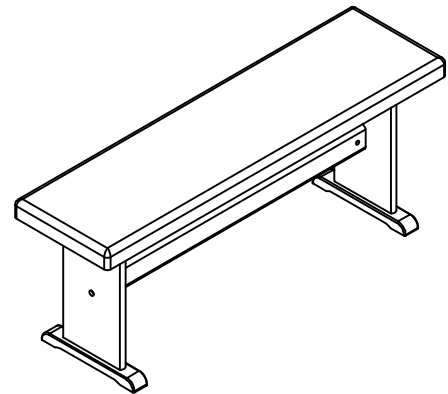

ASSEMBLY PREPARATION

1. Remove all packaging materials, staples and packing straps from the carton.
2. Refer to Parts List and Hardware List, and ensure parts and hardware are correct before assembly. Contact customer service for missing parts.
3. Place all wooden parts on a clean, flat and soft surface (e.g. carpet or rug) to prevent scratch and damage to parts.

SAFETY PRECAUTION

1. KEEP ALL HARDWARE PARTS OUT OF REACH OF CHILDREN.
2. DISPOSE PLASTIC PACKAGING MATERIAL IMMEDIATELY TO AVOID ANY RISK OF SUFFOCATION TO CHILDREN AND ANIMALS.





TIPS FOR ASSEMBLY

1. Allow ample room for assembly and assemble the product near where product will be placed.
2. Assemble the product on a surface that does not scratch or damage the exterior gloss and finish of the furniture.
3. Identify all of the parts, hardware and quantities required for each step.
4. During assembly, do not over-tighten any fittings as this may cause damage.
5. DO NOT USE POWER TOOLS TO ASSEMBLE THIS PRODUCT.
6. Always place the product on a flat, level surface.
7. Do not sit or stand on the partially assembled product; only use the product for which it is intended.



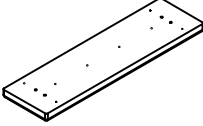

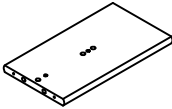
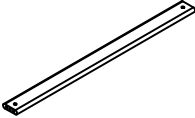

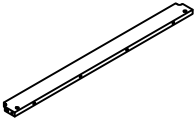

CARE AND MAINTENANCE

- Wipe clean with a soft, dry cloth; avoid the use of harsh chemicals or household cleaners as they may damage the exterior finish of the furniture.
- Hardware may loosen over time. Periodically, check that all connections are tight; re-tighten as necessary.
- Solid wood is impacted by heat and humidity fluctuations which may cause small joint separations or hairline cracks; place the furniture away from direct sunlight and air conditioning vents, heating vents or units to protect the furniture.

Parts List

ITEM	DESCRIPTION	PART	QTY	ITEM	DESCRIPTION	PART	QTY
6	Bench Seat		1pc	9	Leg Base		2pc
7	Leg Panel		2pc	10	Stretcher		1pc
8	Side Rail		2pc	11	Seat Support		1pc

Hardware List

ITEM	DESCRIPTION	HARDWARE	QTY	ITEM	DESCRIPTION	HARDWARE	QTY
A	Screw	 5*25mm	4pcs	E	Screw	 6*45mm	4pc
B	Screw	 5*50mm	8pcs	F	Screw Nut	 6*13mm	4pcs
C	Wood Dowel	 10*50mm	14pcs	G	Cover	 D15*7	4pcs
I	Screw	 3.5*45mm	4pcs	H	Allen Key		1pcs

Instructions for Installing Barrel Nut

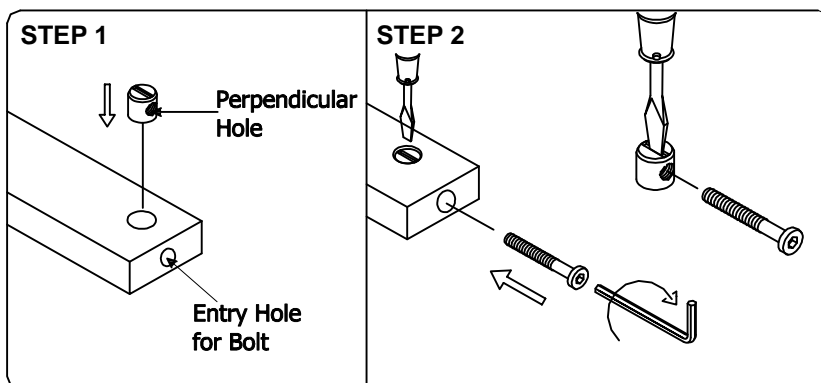

STEP 1
Insert Barrel Nut with the perpendicular hole facing and in-line with the drill hole that the bolt is to be inserted.

STEP 2
Use a Flat-head Screwdriver to hold Barrel Nut in position before inserting bolt to thread into the Barrel Nut.

Parts Assembly Overview

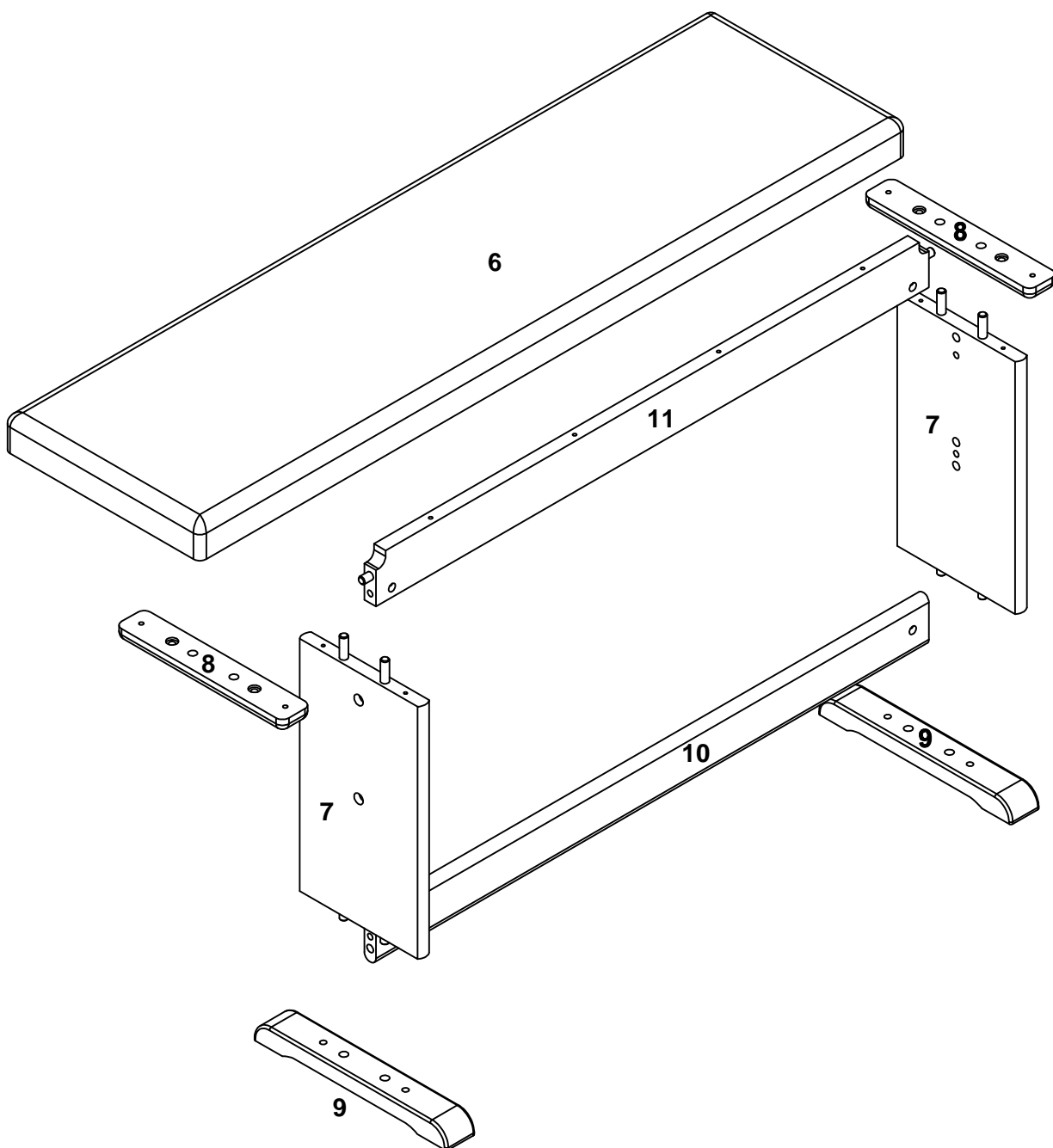

STEP 1

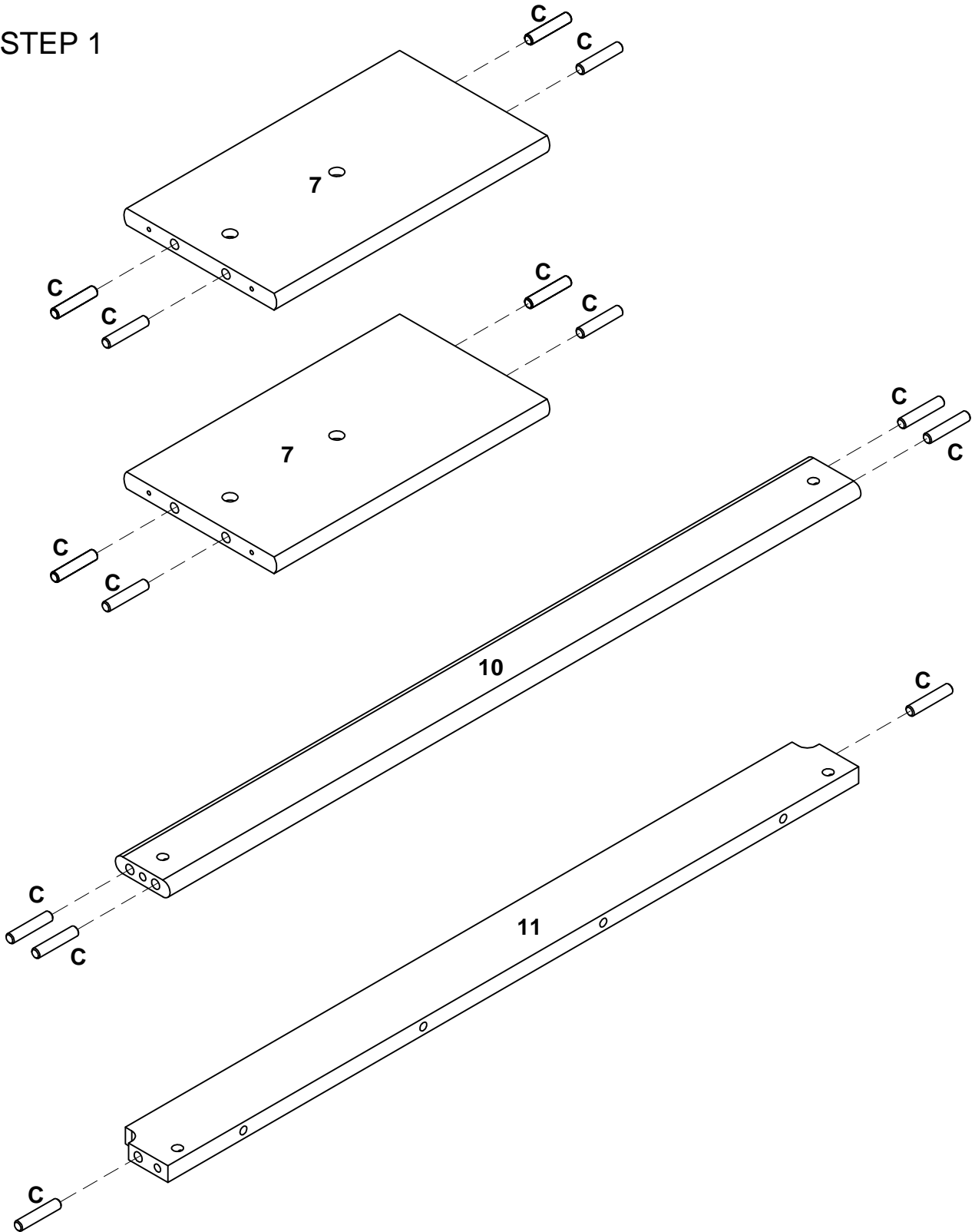

a) Lay Leg Panel (7), Stretcher (10) and Seat Support (11) on a material that does not scratch or damage the parts and insert Wood Dowel (C) into the designated holes as shown.

STEP 2

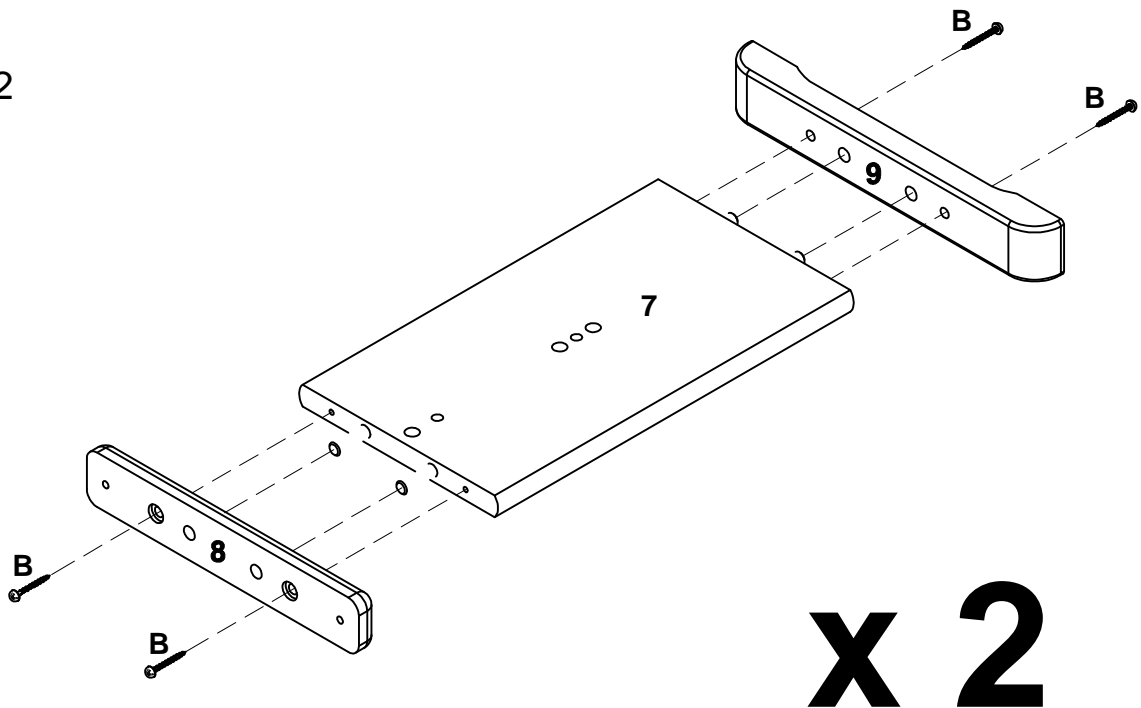

- a) Attach Side Rail (8) and Leg Base (9) to Leg Panel (7) from STEP 1 via wood dowels on (7).
b) Use Screw (B) to fasten (8) and (9) to (7).
-

STEP 3

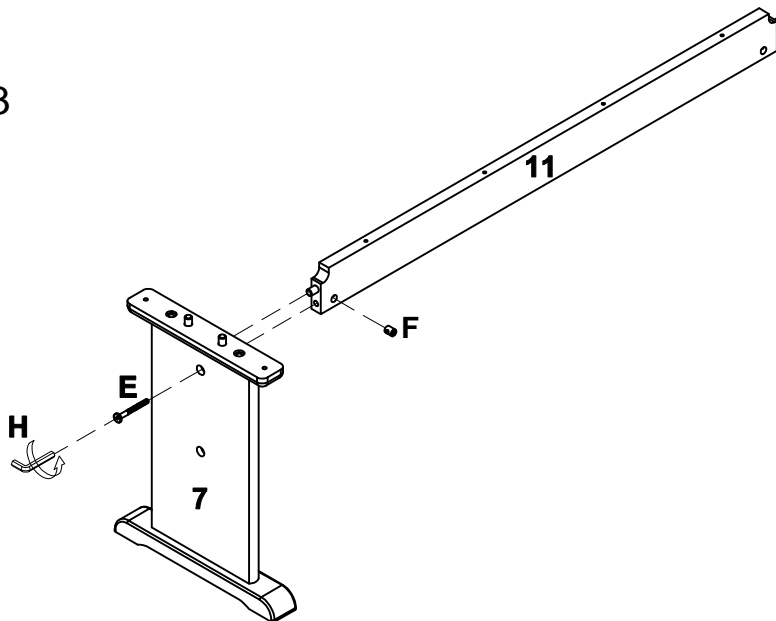

- a) Set Leg Panel assembly from STEP 2 vertically as shown.
b) Insert Barrel Nut (F) into designated hole on Seat Support (11). Refer to Page 2 for Instructions on installing Barrel Nut.
c) With assistance, attach (11) to Leg Panel (7) via wood dowel on (11). Insert Screw (E) through screw hole on (7) and (11) to screw onto the Barrel Nut on (11). Use Allen Key (H) to drive and tighten (E).

STEP 4

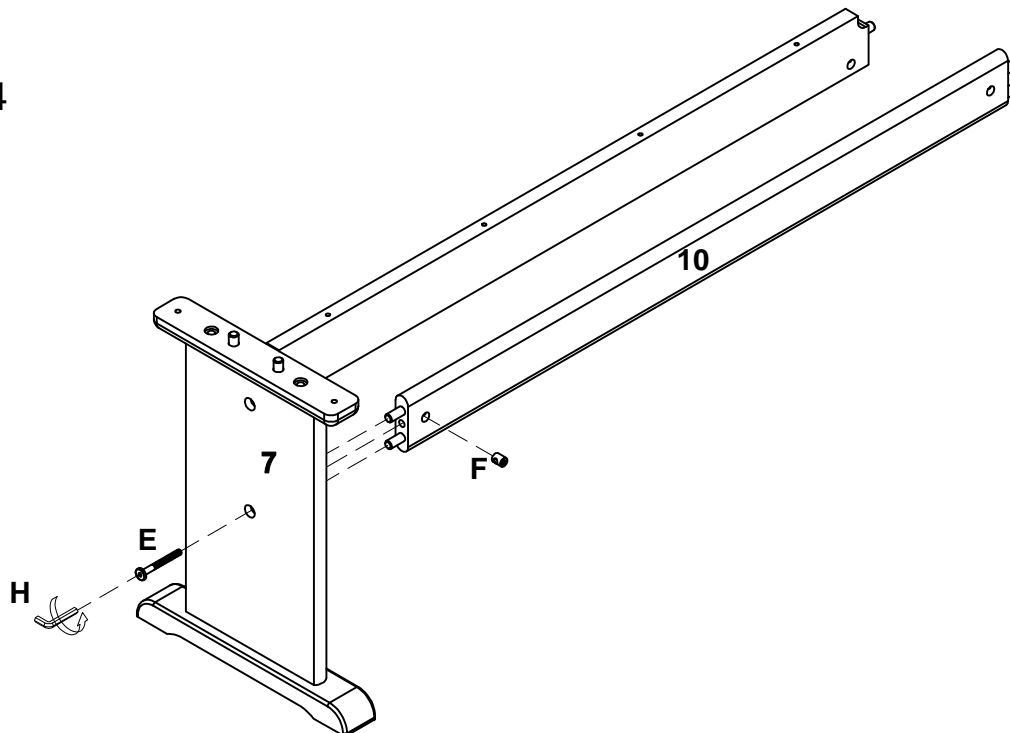

- a) Insert Barrel Nut (F) into designated hole on Stretcher (5) from STEP 1.
b) With assistance, attach (10) to Leg Panel (7) via wood dowels on (10). Insert Screw (E) through screw hole on (7) and (10) to screw onto the Barrel Nut on (10). Use Allen Key (H) to drive and tighten (E).
-

STEP 5

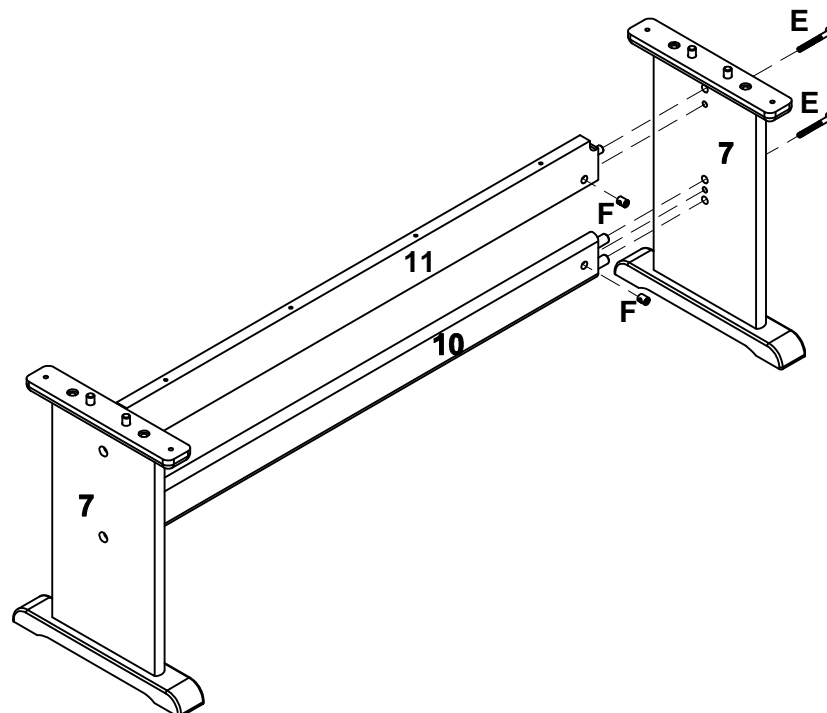

- a) With assistance, attach the second Leg Panel assembly from STEP 2 to Stretcher (10) & Seat Support (11) via wood dowels on (10 & 11)
b) Insert Screw (E) through screw hole on (7) and (11) to screw onto the Barrel Nut on (10 & 11). Use Allen Key (H) to drive and tighten (E).

STEP 6

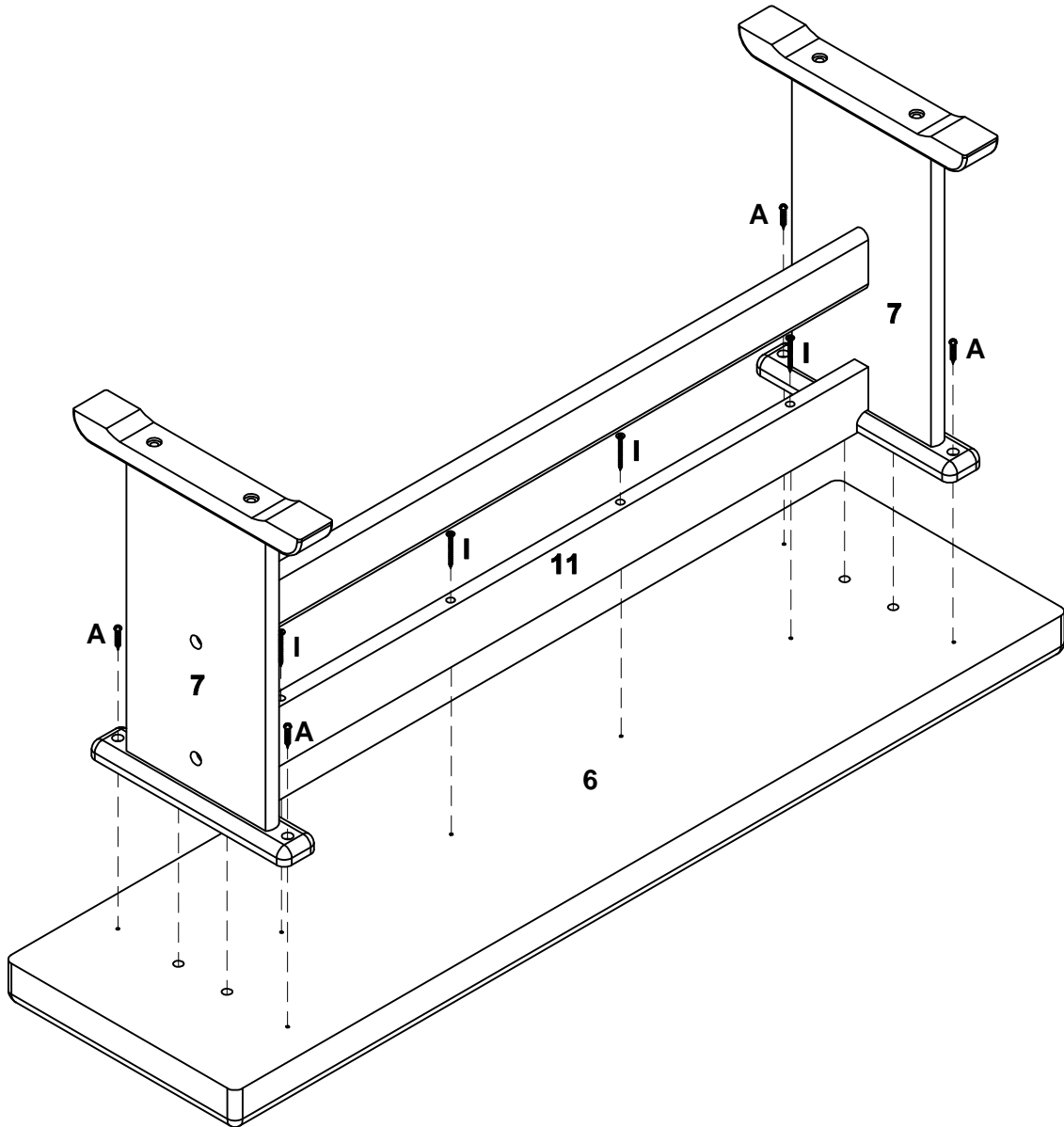

- Lay Bench Seat (6) bottom-side up on a material that does not scratch or damage the part.
- Attach the assembly from STEP 5 to (6) via wood dowels on Side Panel (7).
- Use Screw (A) to fasten Side Rail to (6) and Screw (I) to fasten Seat Support (11) to (6).
- Set the bench right-side up.

STEP 7

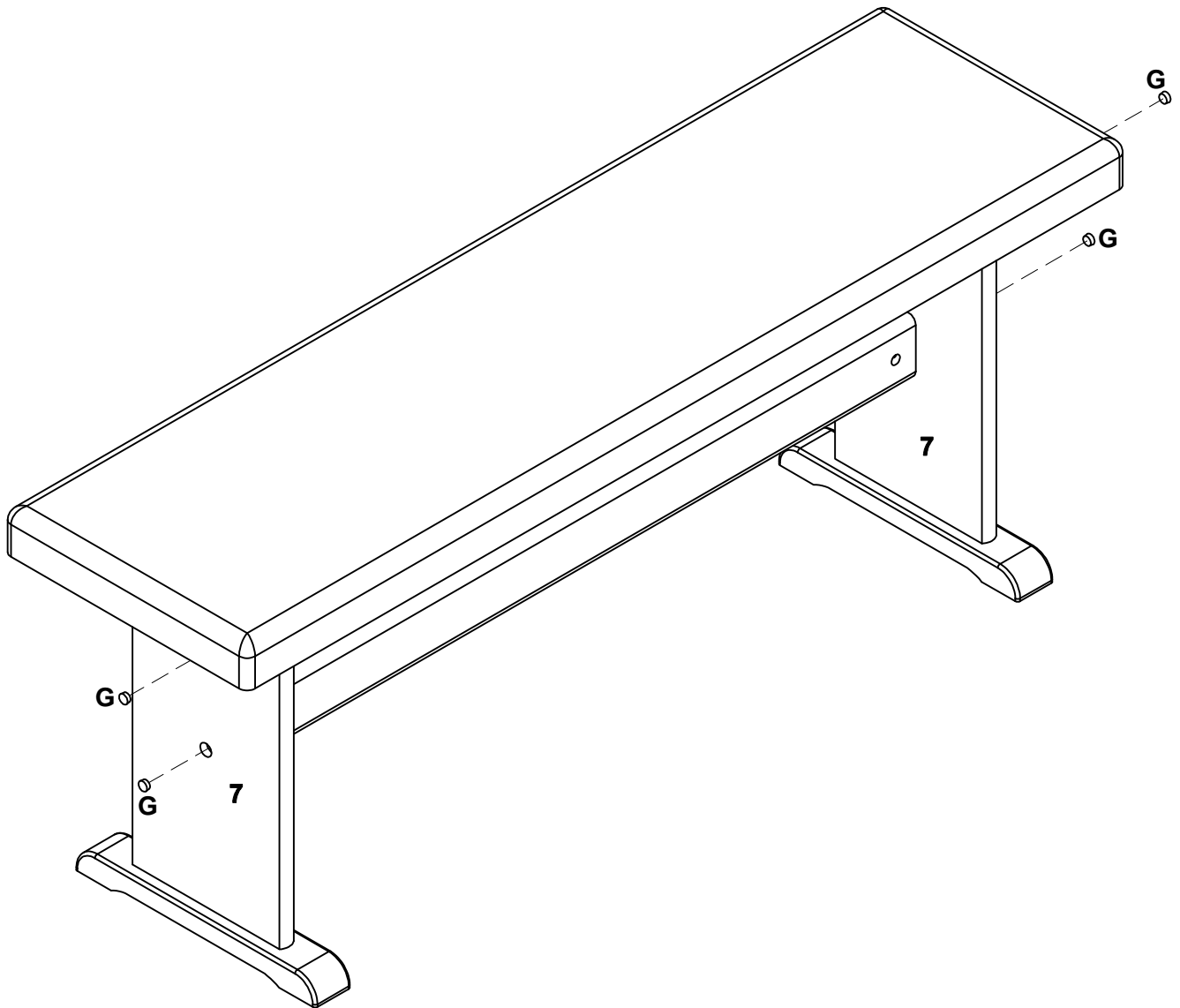

- a) Use Cover (G) to conceal screw holes on (7).
The assembly of the bench is complete.