







Examine all packaging material for small parts that may have come loose during shipment. Periodic checks are recommended to insure that all components are in proper position, tight and free from damage. Keep this assembly instruction for future reference. Adult assembly is required.

HARDWARE LIST

- A (10) 1/4" x 5/8" Allen Bolts
- B (4) 1/4" x 1/2" Allen Bolts
- C (2) 1/4" x 1" Allen Bolts
- D (12) 1/4" Flat Washers
- E (12) 1/4" Spring Washers
- F (1) Allen Wrench

PARTS LIST

- G (1) Back Panel
- H (1) Seat Base
- I (4) Legs
- J (1) Cross Brace

PART	QTY	HARDWARE	PART	QTY	HARDWARE
A	10		B	4	
C	8		D	2	
E	10		F	1	

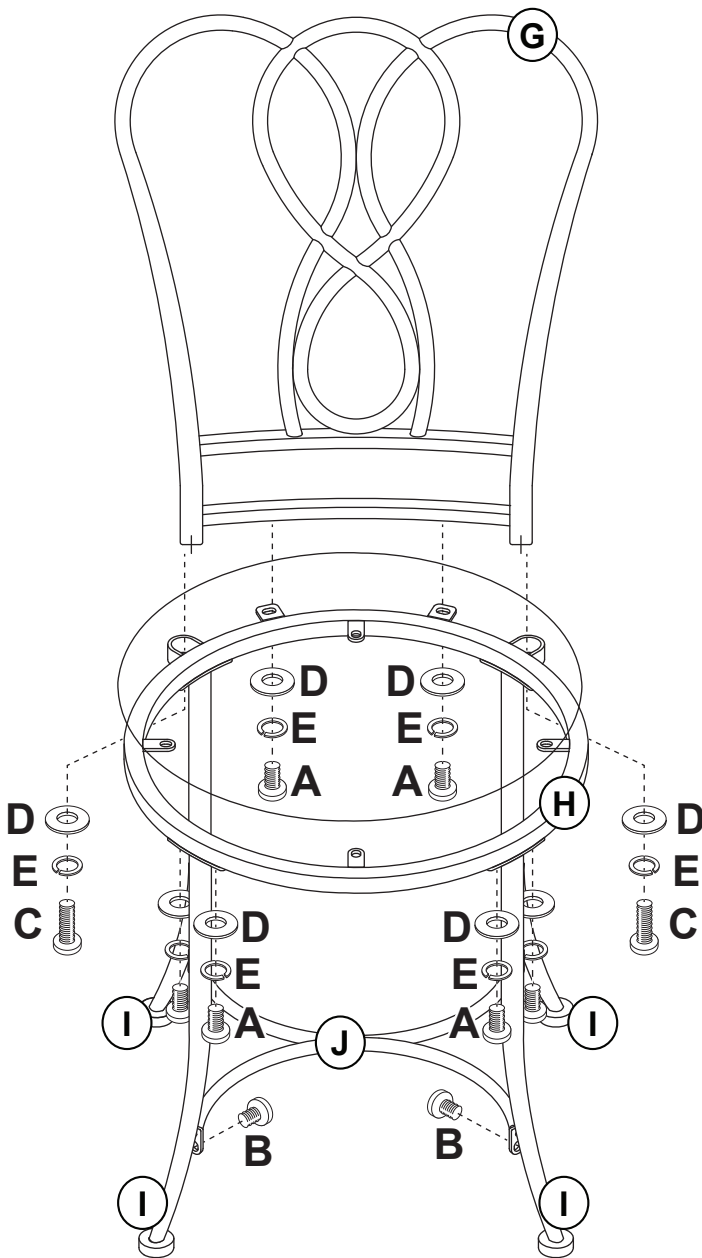

STEP 1

Begin assembly by attaching Back Panel (G) to Seat Base (H), using 1 Allen Bolt (C), 1 Spring Washer (E) & 1 Flat Washer (D) per side, and 2 Allen Bolts (A), 2 Spring Washers (E) and 2 Flat Washers (D) from the center.

STEP 2

Next attach all 4 Legs (I) to Seat Base (H) using 2 Allen Bolts (A), 2 Spring Washers (E) & 2 Flat Washers (D) per leg. Only hand tighten bolts for this step.

STEP 3

Next attach Cross Brace (J) to each Leg (I) using 1 Allen Bolt (B). Tighten all bolts from Steps 1 - 3 here using Allen Wrench (F) provided. The assembly is now complete.

CARE & MAINTENANCE: The touch of a soft cloth is all the maintenance the finish will ever need. Please do not use harsh or abrasive cleaners for polishing, as they may cause damage to the finish. Periodic checks are recommended to make sure that all hardware is securely tightened.