

Maximum capacity : 110 kgs/242 Lbs

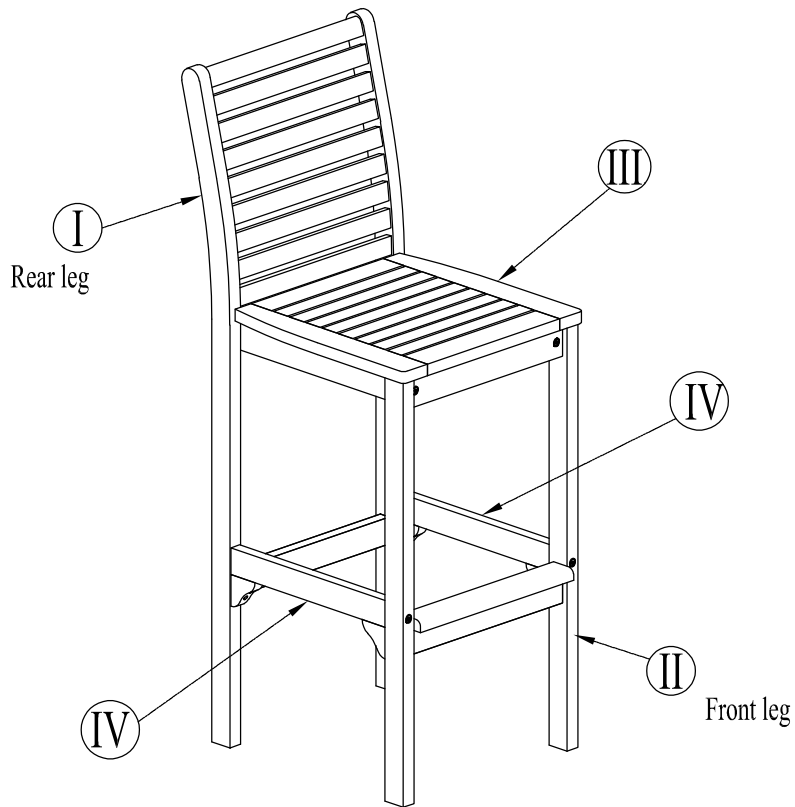

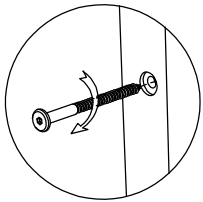

TIGHTEN



LOOSEN

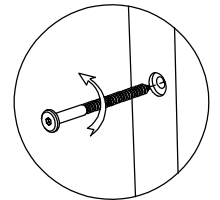

NOTE: 50% TIGHTEN BEFORE FIXING ALL BOLTS & SCREWS

### COMPONENTS LIST

<p>Ⓘ</p> <p>Rear Leg</p> <p>Q'ty 1</p>	<p>Ⓜ</p> <p>Front Leg</p> <p>Q'ty 1</p>	<p>Ⓜ</p> <p>Q'ty 1</p>	<p>Ⓜ</p> <p>Q'ty 2</p>
--	---	------------------------	------------------------

### HARDWARE LIST

A		4	Screw 7 x 60	C		4	Screw 4 x 35
B		4	Screw 7 x 90	D		2	Allen Key
				E	Supporting tools Screw driver		

# Step 1

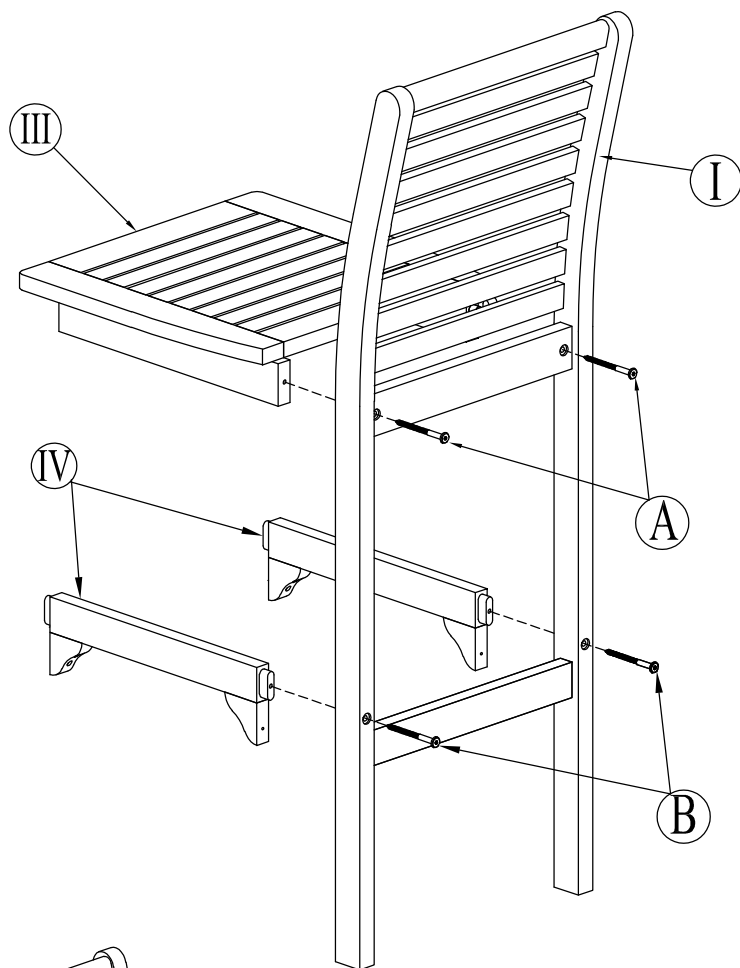

# Step 2

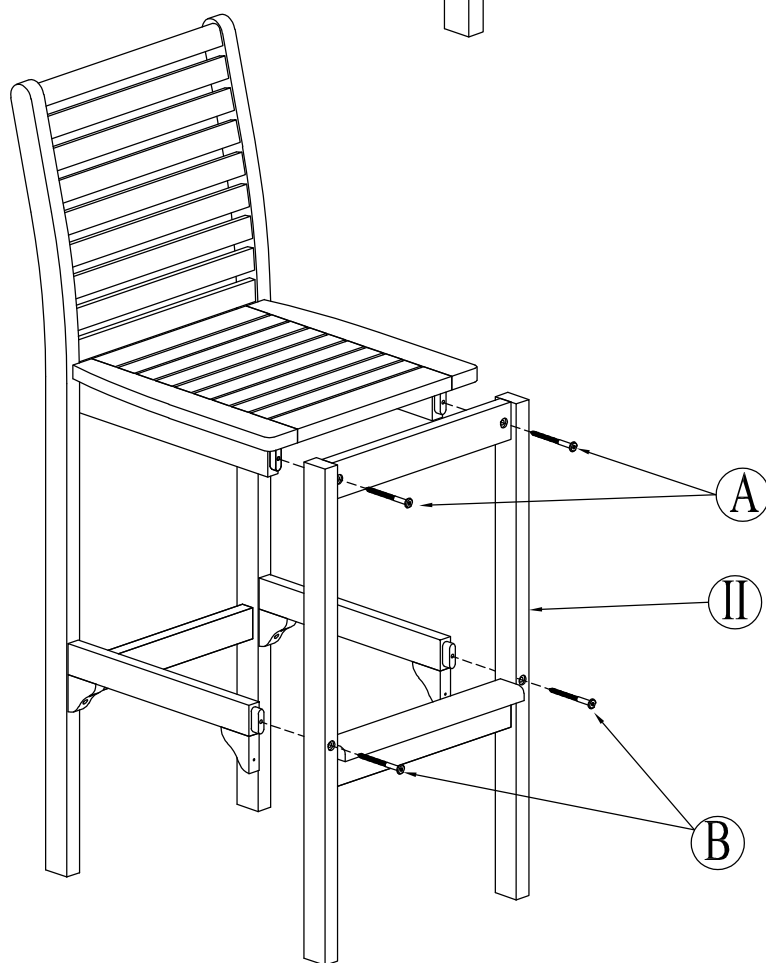

# Step 3

